

HIAB 288 Range 24-28 tm

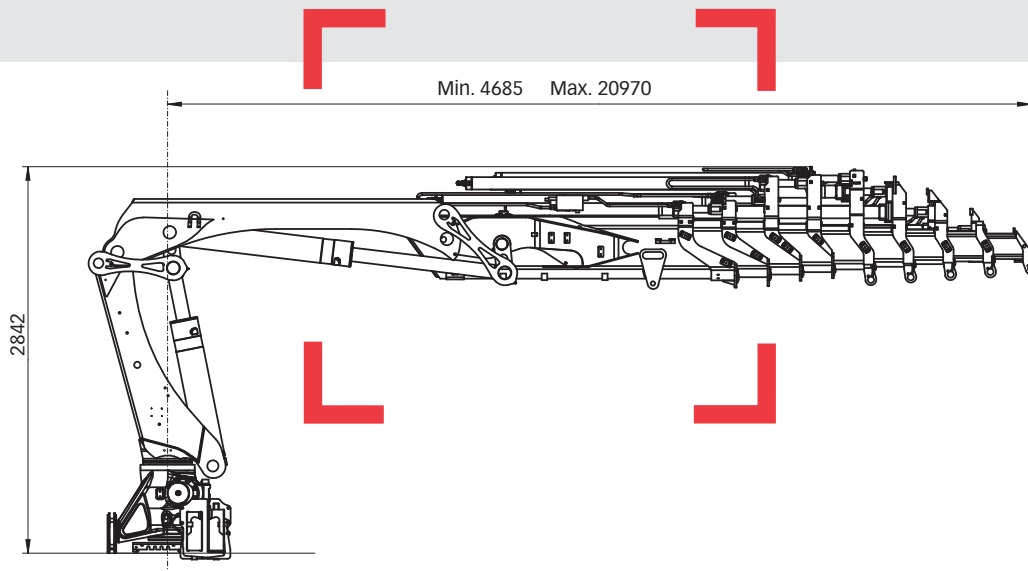

Technical data

Contents

Introduction.....	3
Safety Regulations.....	4
Disclaimer	4
Explanation of Symbols.....	4
Explanation of Diagrams	4
Specific Technical Data.....	7
HIAB XS 288 E-4 CL.....	8-17
HIAB XS 288 E-4 CL.....	8
HIAB XS 288 E-5 CL.....	10
HIAB XS 288 E-6 CL.....	12
HIAB XS 288 E-7 CL.....	14
HIAB XS 288 E-8 CL.....	16
HIAB XS 288 E-4 CL.....	18-25
HIAB XS 288 EP-2 CL	18
HIAB XS 288 EP-3 CL	20
HIAB XS 288 EP-4 CL	22
HIAB XS 288 EP-5 CL	24
HIAB XS 288 E-4 CL.....	24-35
HIAB XS 288 E-4 Duo	26
HIAB XS 288 E-5 Duo	28
HIAB XS 288 E-6 Duo	30
HIAB XS 288 E-7 Duo	32
HIAB XS 288 E-8 Duo	34
HIAB XS 288 E-4 CL.....	36-43
HIAB XS 288 EP-2 Duo.....	36
HIAB XS 288 EP-3 Duo.....	38
HIAB XS 288 EP-4 Duo.....	40
HIAB XS 288 EP-5 Duo.....	42
HIAB XS 288 E-4 CL.....	44-53
HIAB XS 288 E-4 HiDuo.....	44
HIAB XS 288 E-5 HiDuo.....	46
HIAB XS 288 E-6 HiDuo.....	48
HIAB XS 288 E-7 HiDuo.....	50
HIAB XS 288 E-8 HiDuo.....	52
HIAB XS 288 E-4 CL.....	54-61
HIAB XS 288 EP-2 HiDuo	54
HIAB XS 288 EP-3 HiDuo	56
HIAB XS 288 EP-4 HiDuo	58
HIAB XS 288 EP-5 HiDuo	60
HIAB XS 288 E-4 CL.....	62-71
HIAB XS 288 E-4 HiPro.....	62
HIAB XS 288 E-5 HiPro.....	64
HIAB XS 288 E-6 HiPro.....	66
HIAB XS 288 E-7 HiPro.....	68
HIAB XS 288 E-8 HiPro.....	70

HIAB XS 288 E-4 CL	72-79
HIAB XS 288 EP-2 HiPro	72
HIAB XS 288 EP-3 HiPro	74
HIAB XS 288 EP-4 HiPro	76
HIAB XS 288 EP-5 HiPro	78
HIAB XS 288 E-4 CL	80-101
HIAB XS 288 E-4 HiPro Jib 70X-2.....	80
HIAB XS 288 E-4 HiPro Jib 70X-3.....	82
HIAB XS 288 E-4 HiPro Jib 70X-4.....	84
HIAB XS 288 E-5 HiPro Jib 70X-2.....	86
HIAB XS 288 E-5 HiPro Jib 70X-3.....	88
HIAB XS 288 E-5 HiPro Jib 70X-4.....	90
HIAB XS 288 E-6 HiPro Jib 45X-2.....	92
HIAB XS 288 E-6 HiPro Jib 45X-3.....	94
HIAB XS 288 E-6 HiPro Jib 70X-2.....	96
HIAB XS 288 E-6 HiPro Jib 70X-3.....	98
HIAB XS 288 E-6 HiPro Jib 70X-4.....	100
General Technical Data	103
Table of Measurements	105

Introduction

Safety Regulations

All Technical Data are valid if the User Manual Instructions are followed.

Disclaimer

Hiab cranes have been built to meet the highest standards of safety and service life and have been thoroughly tested. Strength calculations for this model have been carried out in accordance with EN13001. Hiab's certified Quality Assurance System complies with the ISO 9001. Some of the items in our literature may be extra equipment. Certain applications may require an official permit. We reserve the right to change technical specifications without prior notice. Hiab cranes produced for EU-countries are CE-marked and comply with the European Standard EN12999.

Explanation of Symbols



Centre of Gravity



Support leg force

Explanation of Diagrams

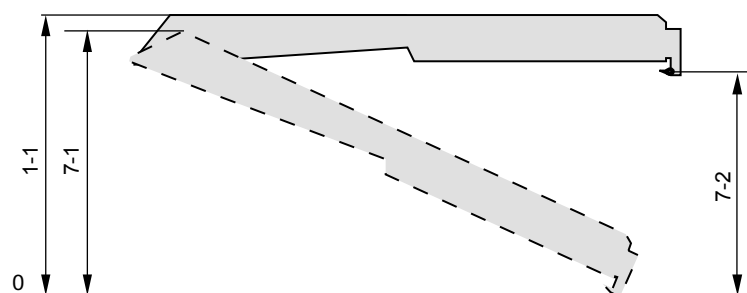

Note: Crane models with X-angle on outer boom show more cases.

Height Stretched Diagram

This diagram indicates the height of the crane in two cases:
 I Outer boom maximum upward and horizontal
 II Outer boom maximum upward and hook attachment in line with theoretical "zero", the crane base's bottom side.

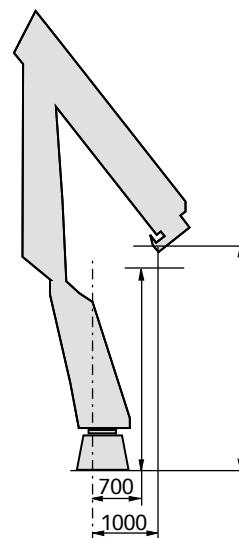

Side View Unfolded Close in Area

This drawing indicates the lifting height at 700 mm and 1000 mm from the heart of the crane column.

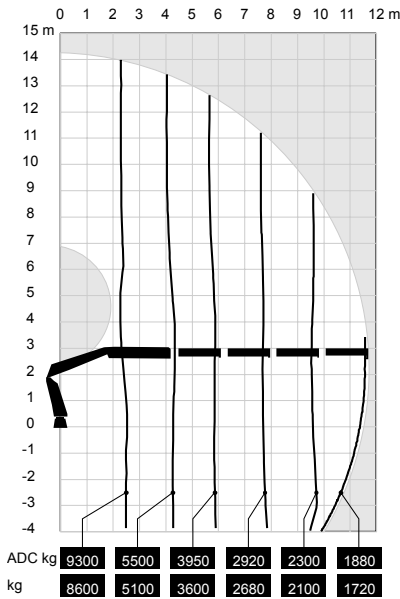

Load Diagram

To the left of the curve the indicated loads can be handled with any loader function provided that the positions of the booms are optimized from a force point of view.

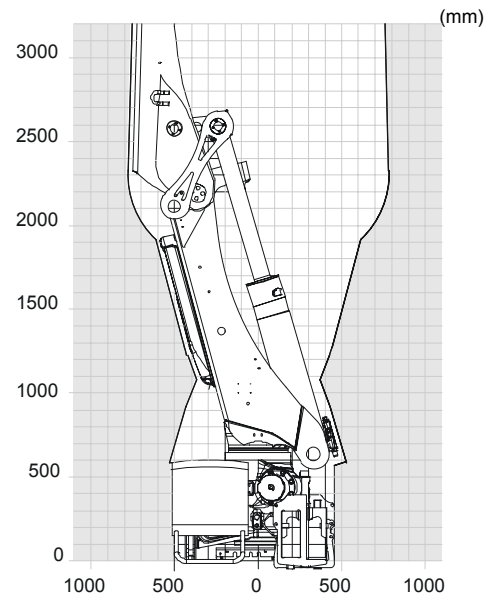

Rotation Diagram

The white silhouette indicates the required space when rotating the crane body. Please note that hydraulic hoses are excluded from the diagram.

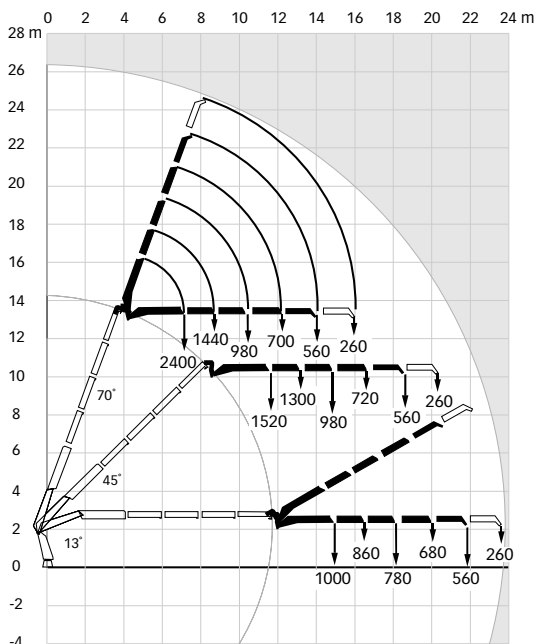

Load Diagram with Jib

This diagram shows the lifting capacity of the Jib in different boom positions.

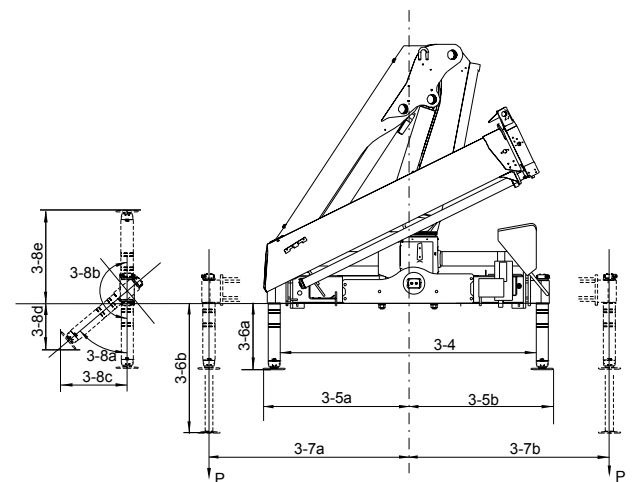

Specific values for stabilizer legs

This drawing shows the dimensions and measurements for the stabilizer legs. To find a configuration of stabilizer legs that match your application first choose a configuration of your choice in **Stabilizer Configuration**. Second, find the measurements in **Dimensions & Measurements**.

Specific Technical Data

Side View Unfolded Stretched

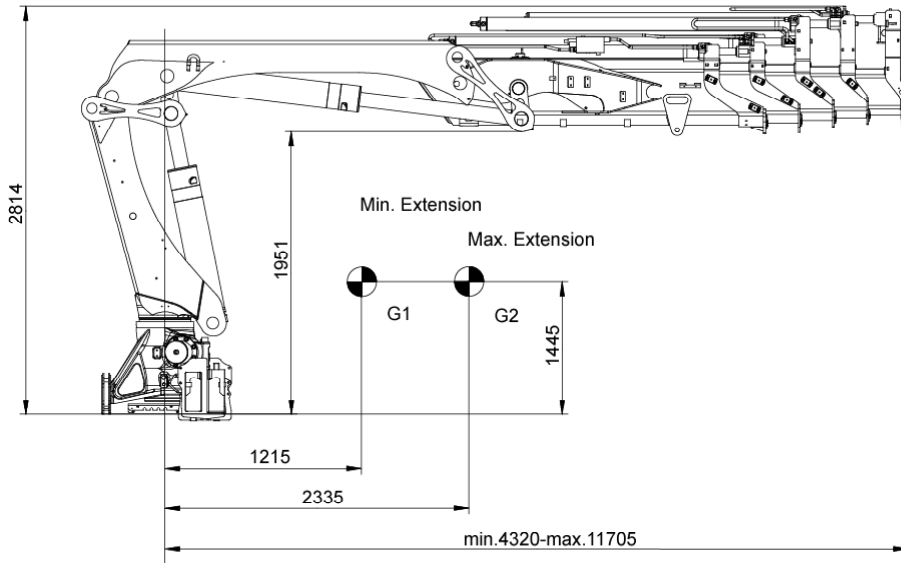

Side View Folded

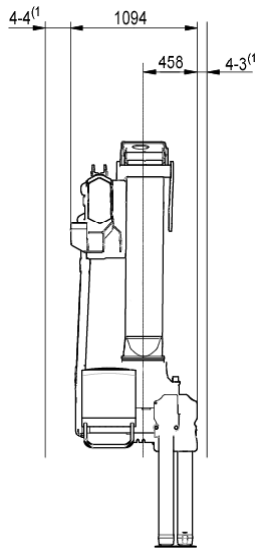

Front View Folded

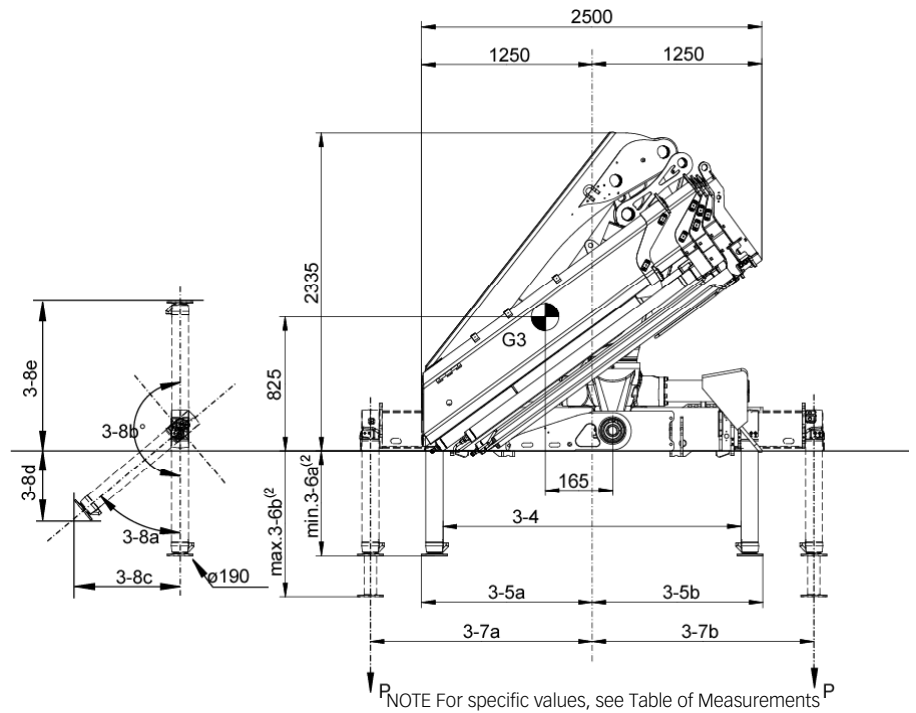

Top View Crane Base

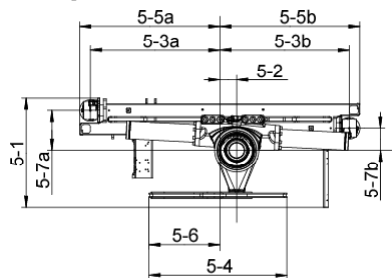

NOTE For specific values, see Table of Measurements

Chassis Installation

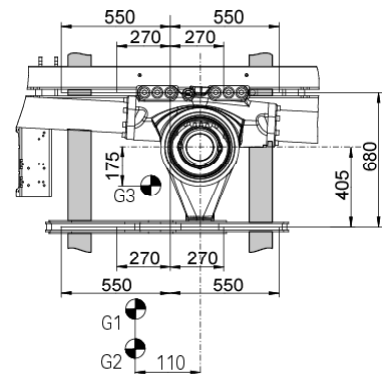

Load Diagram

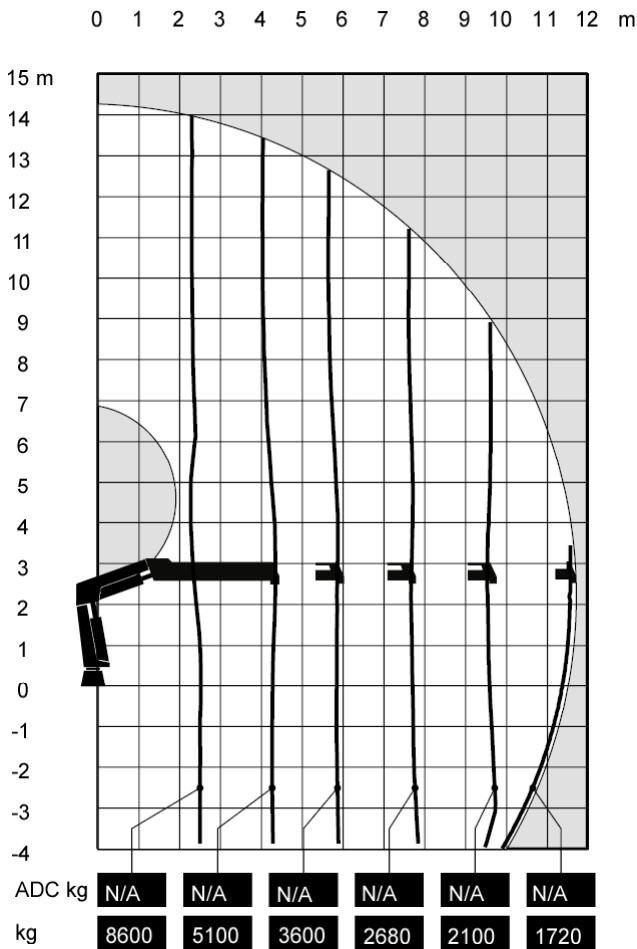

Capacity and performance

Lifting capacity	216.6 (kNm)	
Standard lifting capacity at standard outreach	2.5 (m)	- 8600 (kg)
	4.3 (m)	- 5100 (kg)
	5.9 (m)	- 3600 (kg)
	7.7 (m)	- 2680 (kg)
	9.6 (m)	- 2100 (kg)
Manual lifting capacity at extension	11.6 (m)	- 1720 (kg)
	13.7 (m)	- 1380 (kg)
Heavy lift capacity at heavy lift outreach	15.9 (m)	- 1120 (kg)
	2.2 (m)	- 9600 (kg)
Hydraulic boom extension	7.4 (m)	
Manual max outreach	18.6 (m)	
Lifting height above installation level hydraulic	14.3 (m)	
Lifting height above installation level manual	18.5 (m)	
Slewing torque	34 (kNm)	
V80 Slewing speed	15 (°/s)	
Slewing angle	420 (°)	
Lifting speed	1.4 m/s	

Functional demands

Recommended oil flow low	50 (l/min)
Recommended oil flow high	70 (l/min)
Working pressure	29 (MPa)
Max slope viable at full capacity	5 (°)

Weights and measurements

Height in folded position	2335 (mm)
Width in folded position	2500 (mm)
Installation space needed	1094 (mm)
Weight of crane	3030 (kg)
Weight support leg equipment	402 (kg)

Side View Unfolded Close in Area

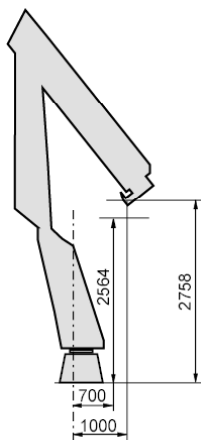

Side View Unfolded Stretched

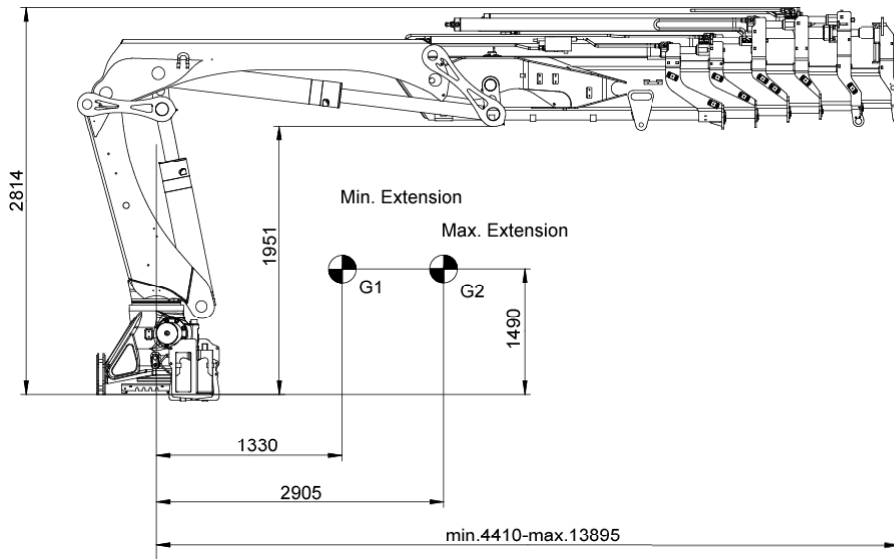

Side View Folded

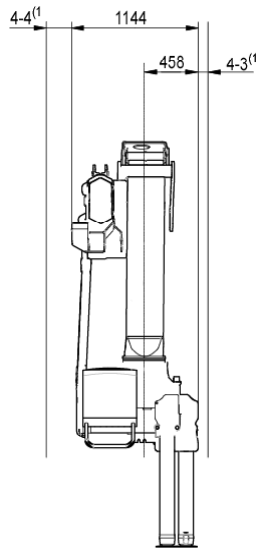

Front View Folded

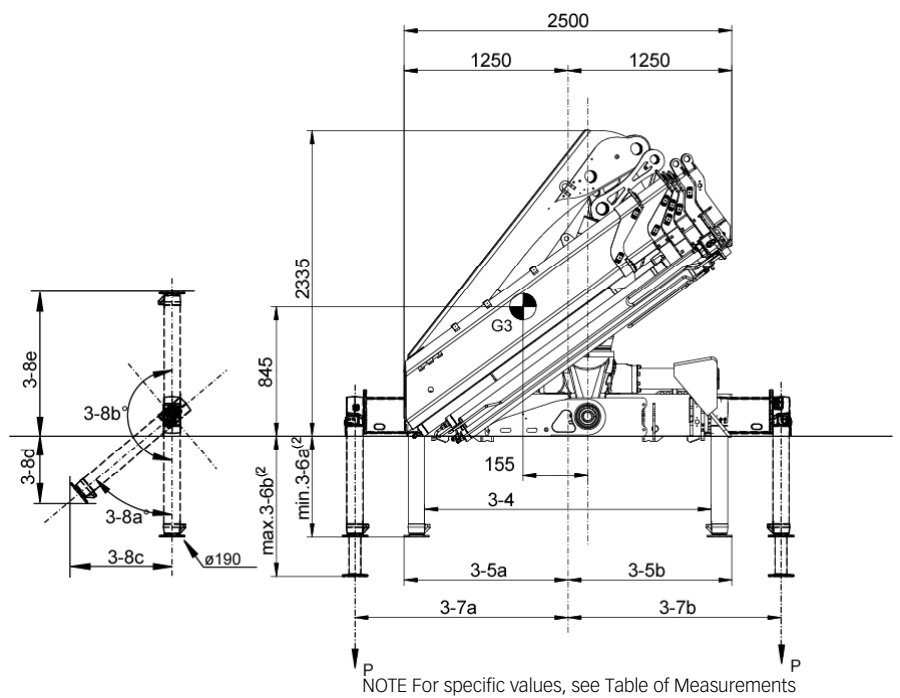

Top View Crane Base

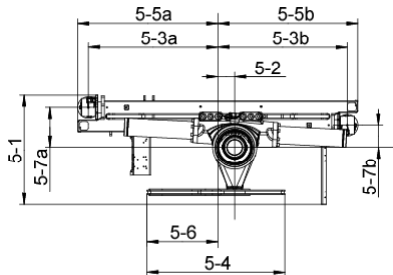

NOTE For specific values, see Table of Measurements

Chassis Installation

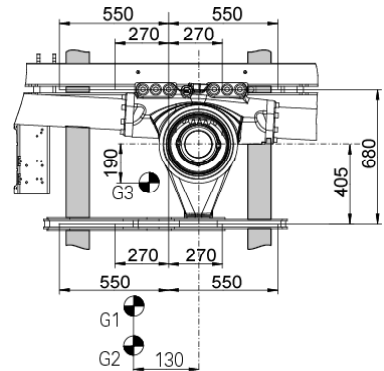

(1) Variable value depending on option.
 (2) Variations may occur depending on mounting position.

Load Diagram

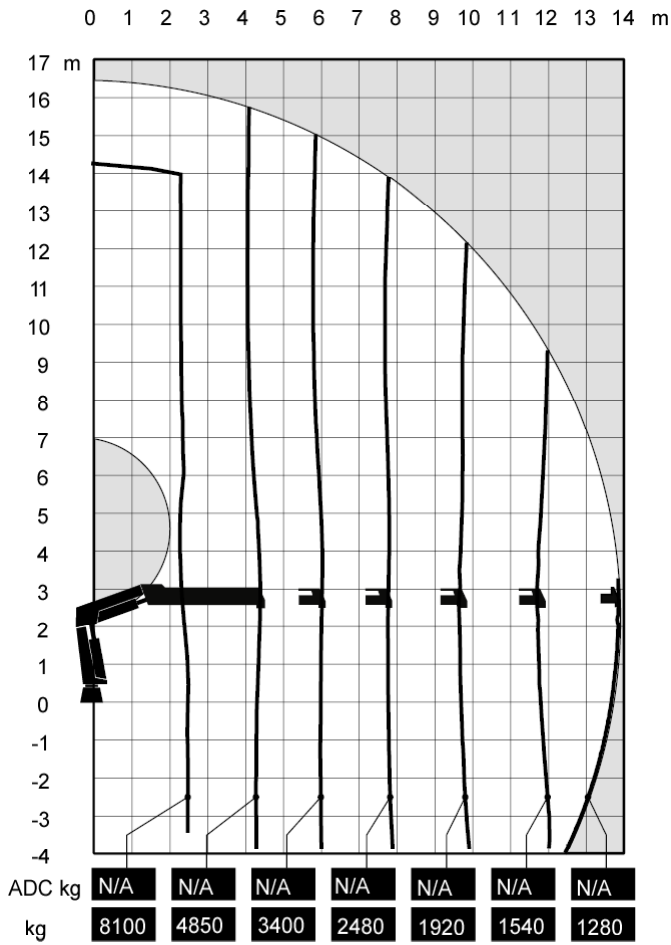

Capacity and performance

Lifting capacity	210.9 (kNm)
Standard lifting capacity at standard outreach	2.6 (m) - 8100 (kg)
	4.4 (m) - 4850 (kg)
	6.0 (m) - 3400 (kg)
	7.8 (m) - 2480 (kg)
	9.7 (m) - 1920 (kg)
	11.7 (m) - 1540 (kg)
	13.8 (m) - 1280 (kg)
Manual lifting capacity at extension	15.8 (m) - 1060 (kg)
	17.5 (m) - 900 (kg)
Heavy lift capacity at heavy lift outreach	2.2 (m) - 9400 (kg)
Hydraulic boom extension	9.5 (m)
Manual max outreach	21.0 (m)
Lifting height above installation level hydraulic	16.5 (m)
Lifting height above installation level manual	20.1 (m)
Slewing torque	34 (kNm)
V80 Slewing speed	15 (°/s)
Slewing angle	420 (°)
Lifting speed	1.7 m/s

Functional demands

Recommended oil flow low	50 (l/min)
Recommended oil flow high	70 (l/min)
Working pressure	29 (MPa)
Max slope viable at full capacity	5 (°)

Weights and measurements

Height in folded position	2335 (mm)
Width in folded position	2500 (mm)
Installation space needed	1144 (mm)
Weight of crane	3210 (kg)
Weight support leg equipment	402 (kg)

Side View Unfolded Close in Area

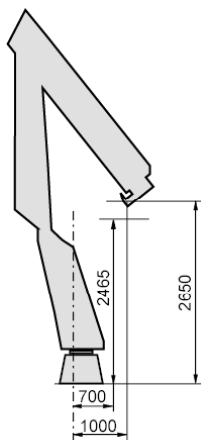

Side View Unfolded Stretched

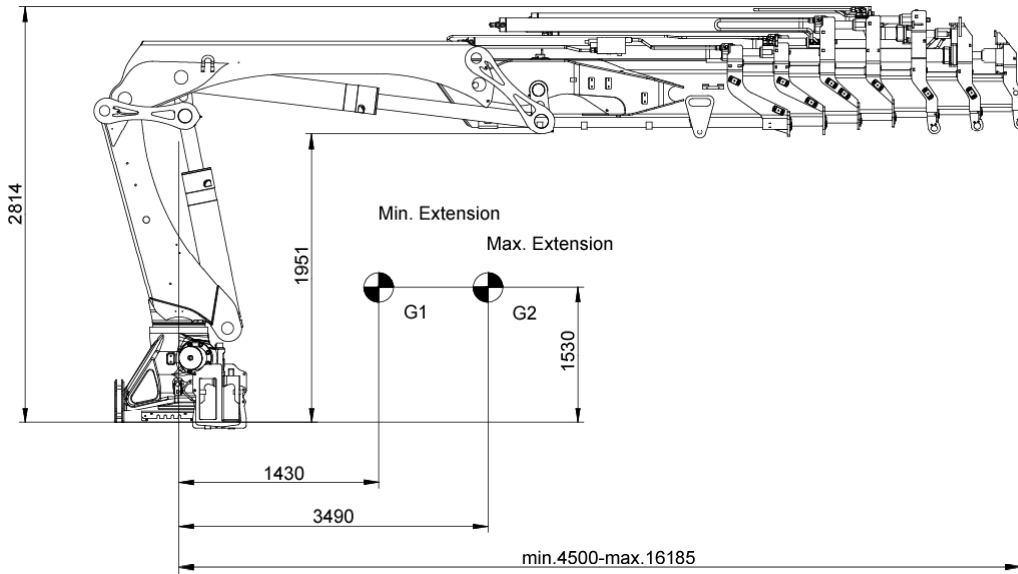

Side View Folded

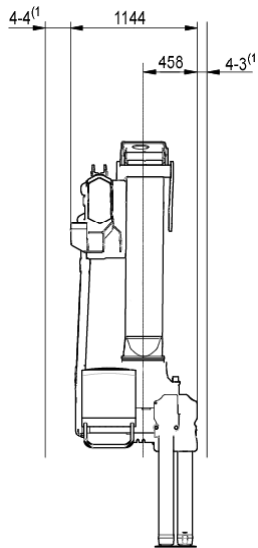

Front View Folded

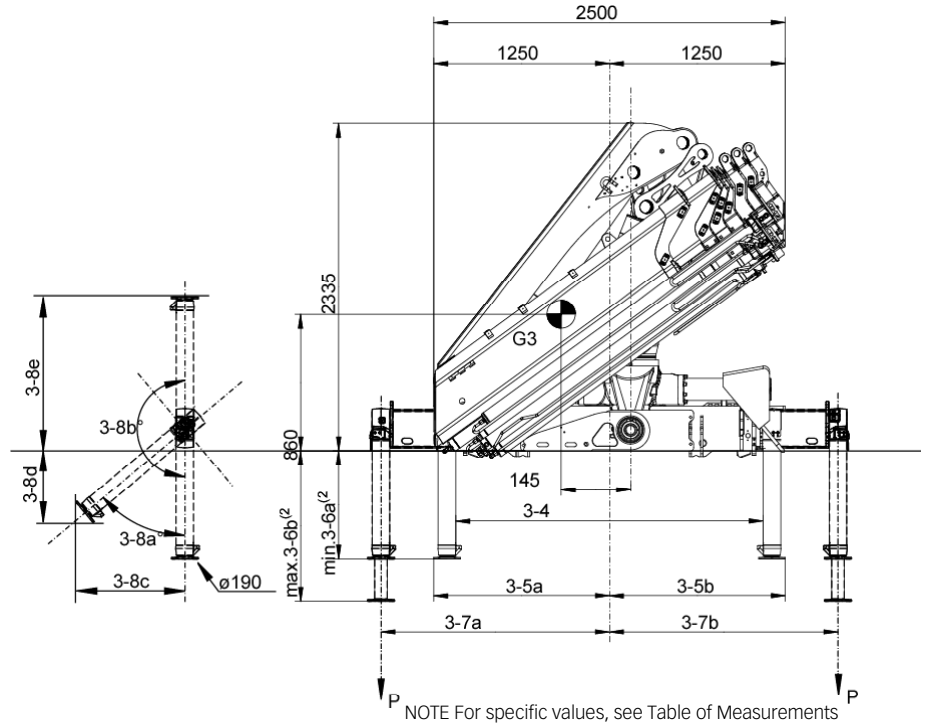

Top View Crane Base

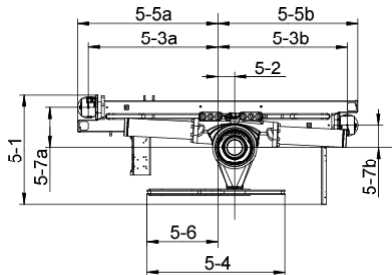

NOTE For specific values, see Table of Measurements

Chassis Installation

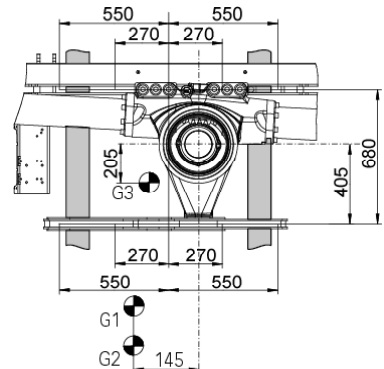

(1) Variable value depending on option.
 (2) Variations may occur depending on mounting position.

Load Diagram

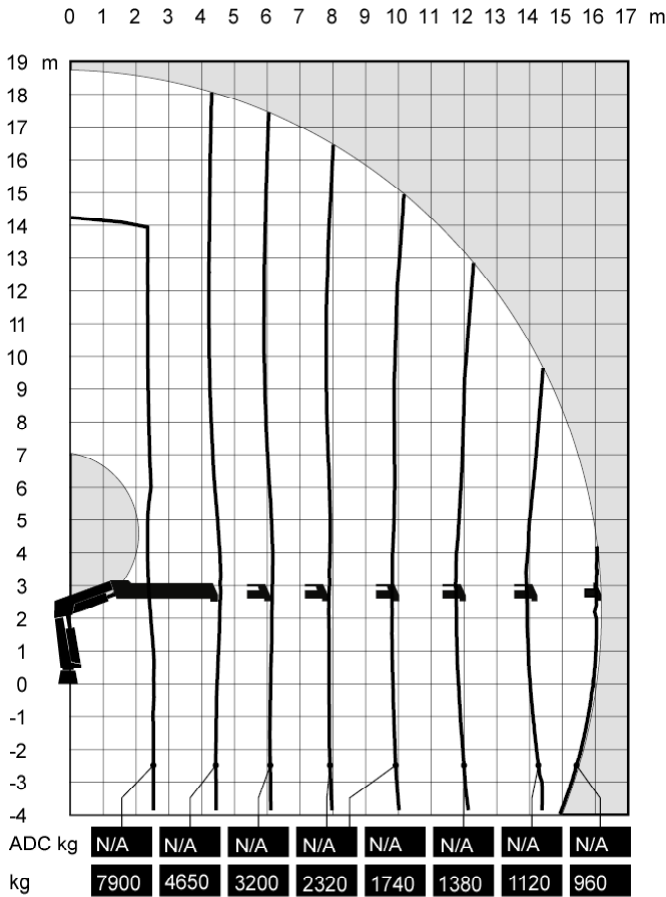

Capacity and performance

Lifting capacity	205.4 (kNm)	
Standard lifting capacity at standard outreach	2.6 (m)	- 7900 (kg)
	4.5 (m)	- 4650 (kg)
	6.1 (m)	- 3200 (kg)
	7.9 (m)	- 2320 (kg)
	9.8 (m)	- 1740 (kg)
	11.8 (m)	- 1380 (kg)
Manual lifting capacity at extension	13.9 (m)	- 1120 (kg)
	16.1 (m)	- 960 (kg)
	20.4 (m)	- 620 (kg)
Heavy lift capacity at heavy lift outreach	2.2 (m)	- 9200 (kg)
Hydraulic boom extension	11.7 (m)	
Manual max outreach	23.3 (m)	
Lifting height above installation level hydraulic	18.8 (m)	
Lifting height above installation level manual	23.1 (m)	
Slewing torque	34 (kNm)	
V80 Slewing speed	15 (°/s)	
Slewing angle	420 (°)	
Lifting speed	1.9 m/s	

Functional demands

Recommended oilflow low	50 (l/min)
Recommended oilflow high	70 (l/min)
Working pressure	29 (MPa)
Max slope viable at full capacity	5 (°)

Weights and measurements

Height in folded position	2335 (mm)
Width in folded position	2500 (mm)
Installation space needed	1144 (mm)
Weight of crane	3380 (kg)
Weight support leg equipment	402 (kg)

Side View Unfolded Close in Area

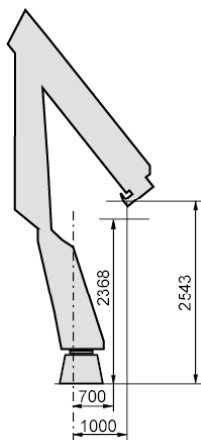

Side View Unfolded Stretched

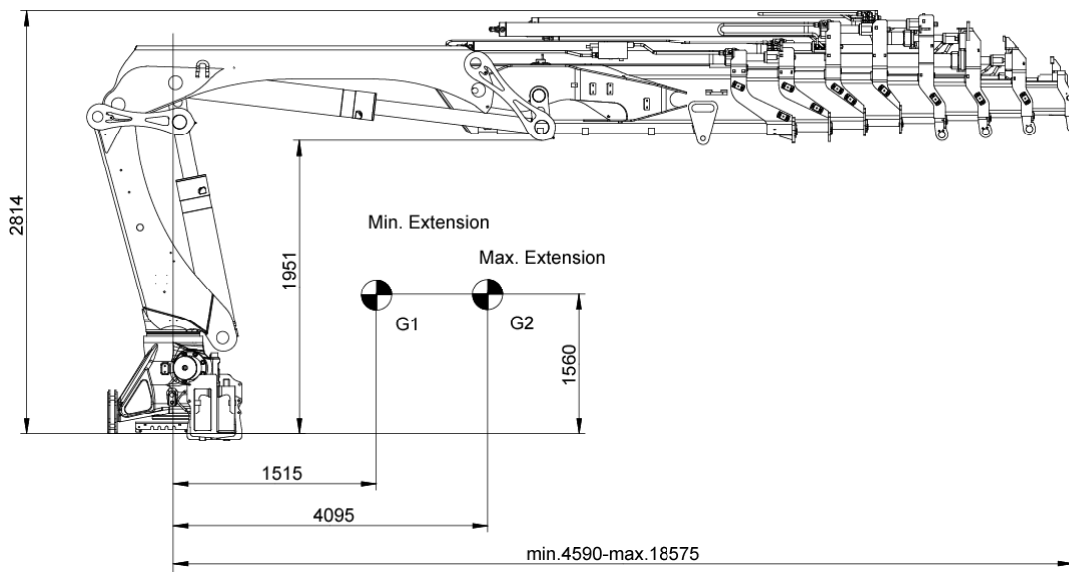

Side View Folded

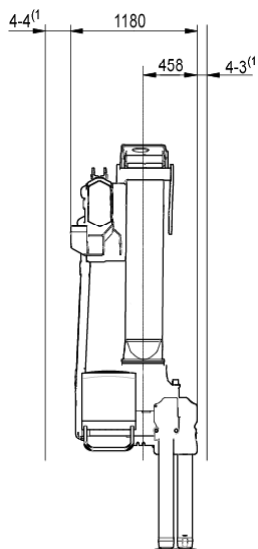

Front View Folded

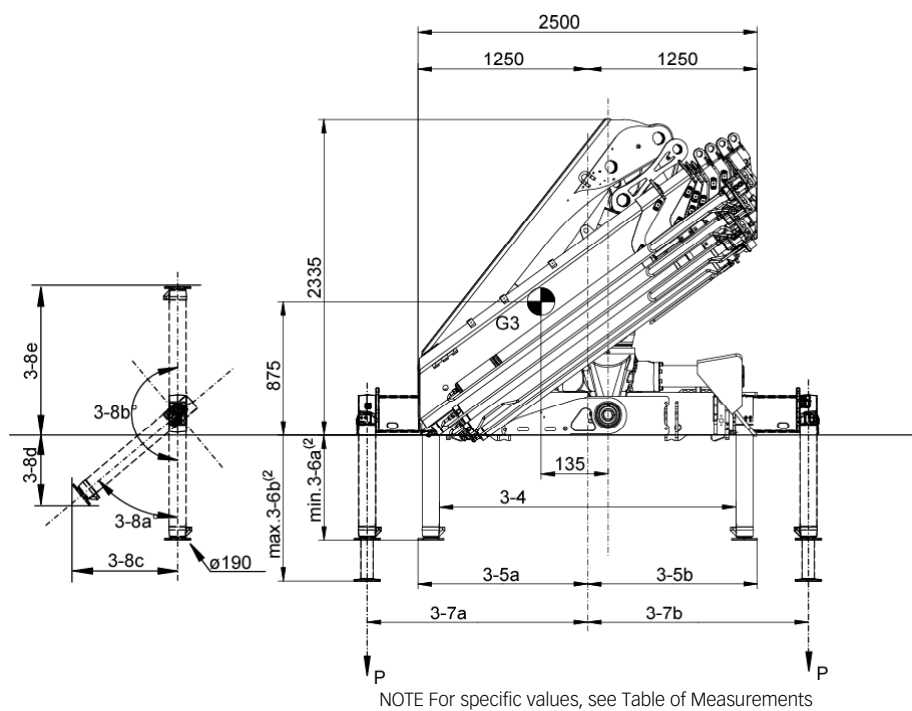

Top View Crane Base

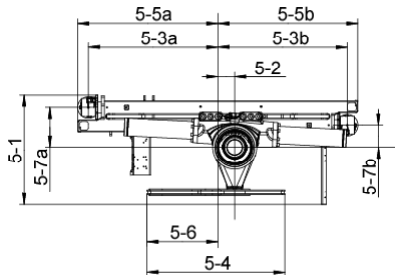

NOTE For specific values, see Table of Measurements

Chassis Installation

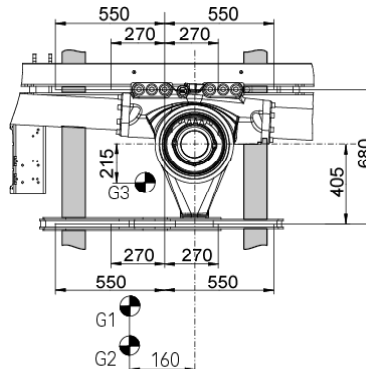

(1) Variable value depending on option.
 (2) Variations may occur depending on mounting position.

Load Diagram

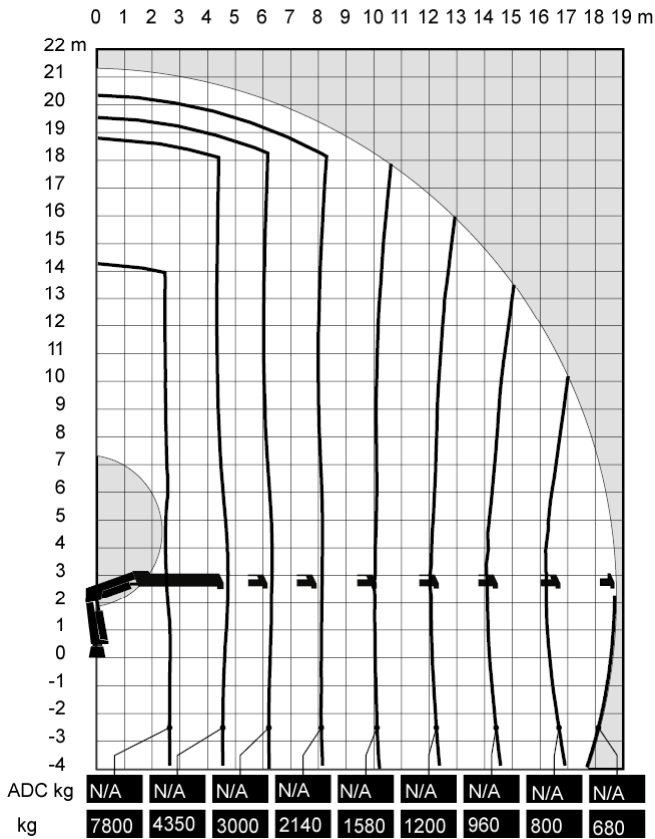

Capacity and performance

Lifting capacity	201.4 (kNm)
Standard lifting capacity at standard outreach	2.6 (m) - 7800 (kg)
	4.7 (m) - 4350 (kg)
	6.3 (m) - 3000 (kg)
	8.1 (m) - 2140 (kg)
	10.0 (m) - 1580 (kg)
	12.0 (m) - 1200 (kg)
Manual lifting capacity at extension	14.1 (m) - 960 (kg)
	16.3 (m) - 800 (kg)
Heavy lift capacity at heavy lift outreach	18.6 (m) - 680 (kg)
	20.1 (m) - 560 (kg)
Manual lifting capacity at extension	21.6 (m) - 460 (kg)
Hydraulic boom extension	2.2 (m) - 9100 (kg)
Manual max outreach	14.0 (m)
Lifting height above installation level hydraulic	23.2 (m)
Lifting height above installation level manual	21.2 (m)
Slewing torque	24.2 (m)
V80 Slewing speed	34 (kNm)
Slewing angle	15 (°/s)
Lifting speed	420 (°)
	2.2 m/s

Functional demands

Recommended oil flow low	50 (l/min)
Recommended oil flow high	70 (l/min)
Working pressure	29 (MPa)
Max slope viable at full capacity	5 (°)

Weights and measurements

Height in folded position	2335 (mm)
Width in folded position	2500 (mm)
Installation space needed	1180 (mm)
Weight of crane	3540 (kg)
Weight support leg equipment	402 (kg)

Side View Unfolded Close in Area

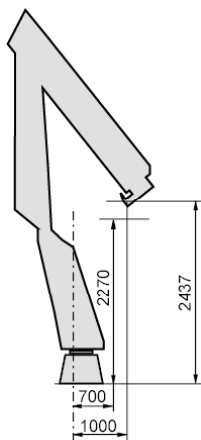

Side View Unfolded Stretched

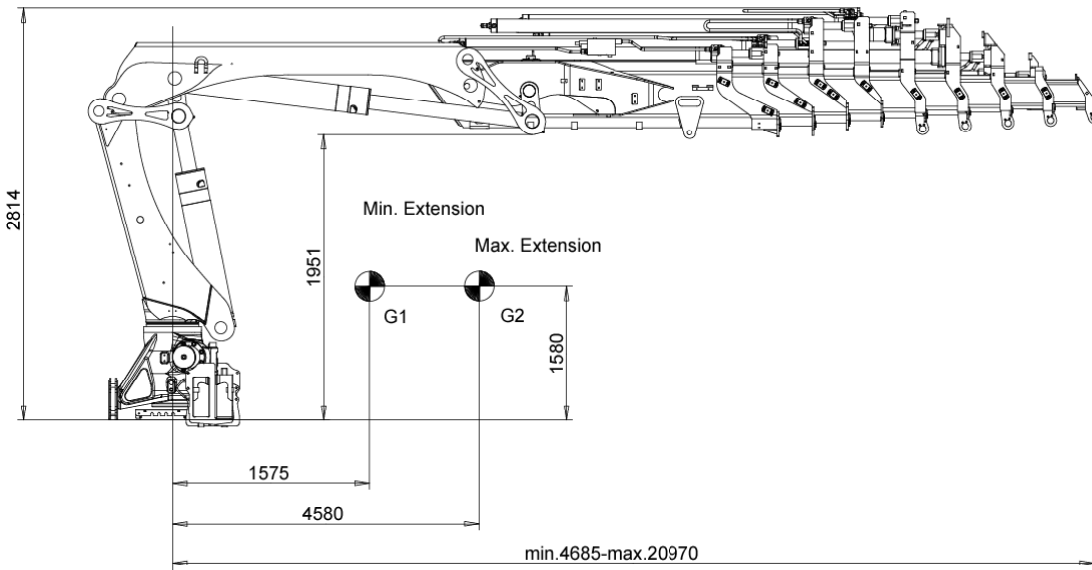

Side View Folded

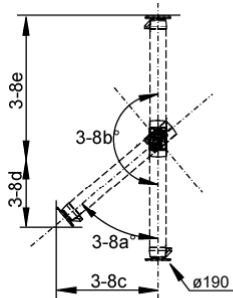
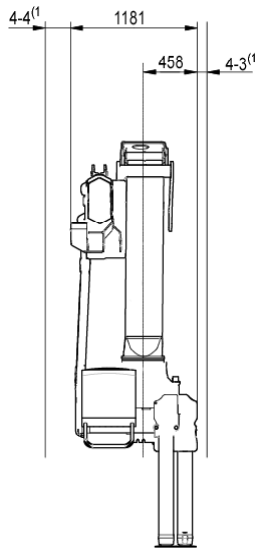

Front View Folded

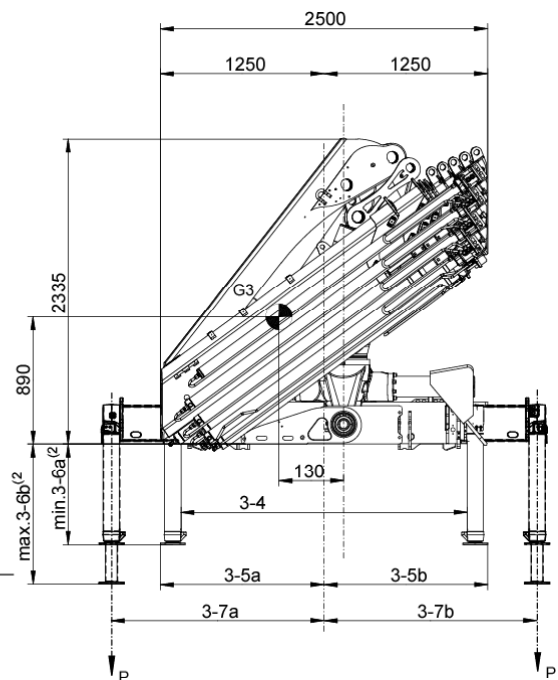

NOTE For specific values, see Table of Measurements

Top View Crane Base

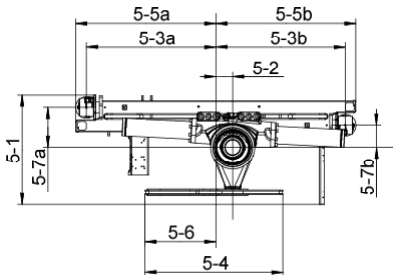

NOTE For specific values, see Table of Measurements

Chassis Installation

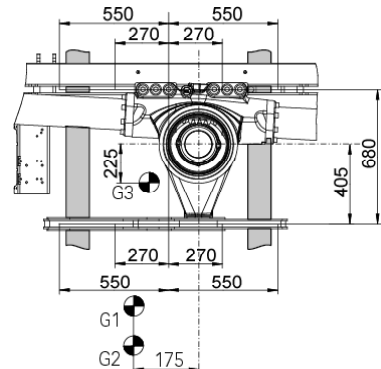

Load Diagram

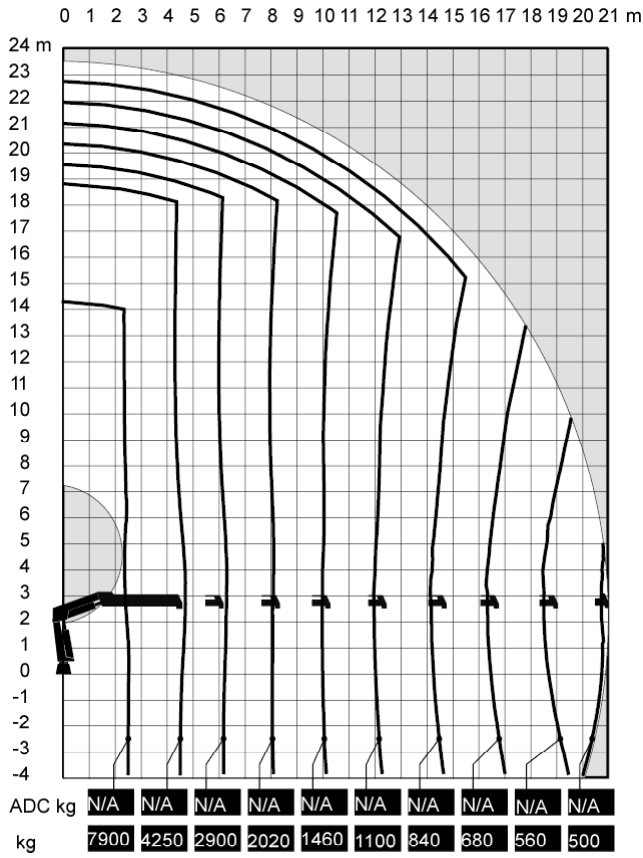

Capacity and performance

Lifting capacity	196.2 (kNm)	
Standard lifting capacity at standard outreach	2.5 (m)	- 7900 (kg)
	4.7 (m)	- 4250 (kg)
	6.3 (m)	- 2900 (kg)
	8.1 (m)	- 2020 (kg)
	10.0 (m)	- 1460 (kg)
	12.0 (m)	- 1100 (kg)
	14.1 (m)	- 840 (kg)
Manual lifting capacity at extension	16.3 (m)	- 680 (kg)
	18.6 (m)	- 560 (kg)
	20.9 (m)	- 500 (kg)
Heavy lift capacity at heavy lift outreach	22.4 (m)	- 400 (kg)
Hydraulic boom extension	16.3 (m)	
Manual max outreach	23.3 (m)	
Lifting height above installation level hydraulic	23.6 (m)	
Lifting height above installation level manual	25.1 (m)	
Slewing torque	34 (kNm)	
V80 Slewing speed	15 (°/s)	
Slewing angle	420 (°)	
Lifting speed	2.5 m/s	

Functional demands

Recommended oil flow low	50 (l/min)
Recommended oil flow high	70 (l/min)
Working pressure	29 (MPa)
Max slope viable at full capacity	5 (°)

Weights and measurements

Height in folded position	2335 (mm)
Width in folded position	2500 (mm)
Installation space needed	1181 (mm)
Weight of crane	3660 (kg)
Weight support leg equipment	402 (kg)

Side View Unfolded Close in Area

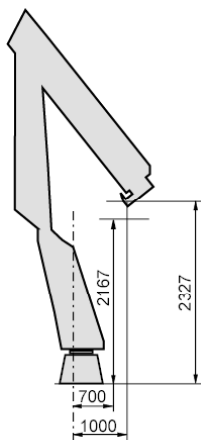

Side View Unfolded Stretched

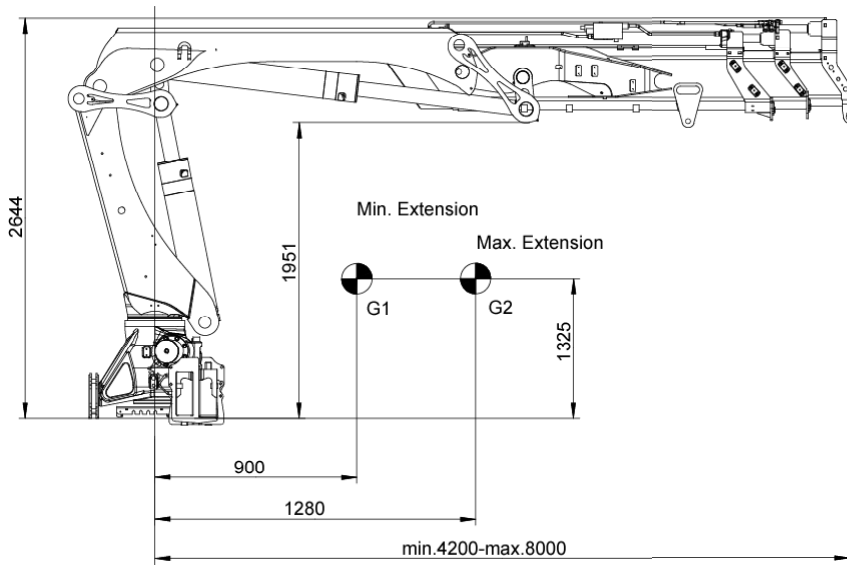

Side View Folded

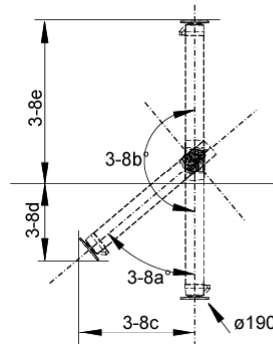
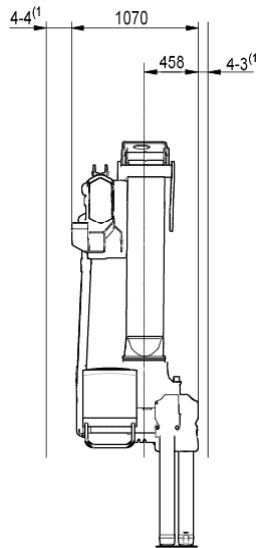

Front View Folded

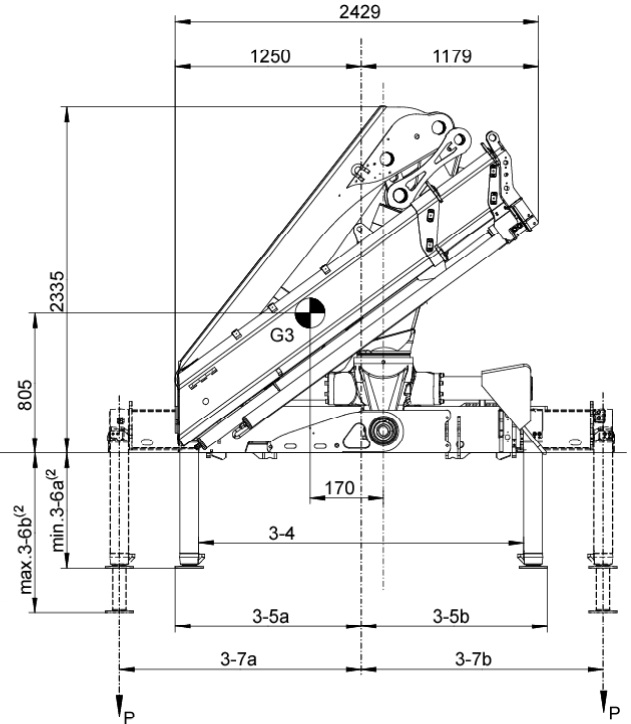

NOTE For specific values, see Table of Measurements

Top View Crane Base

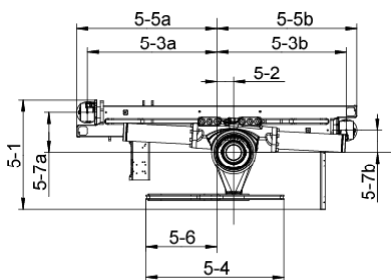

NOTE For specific values, see Table of Measurements

Chassis Installation

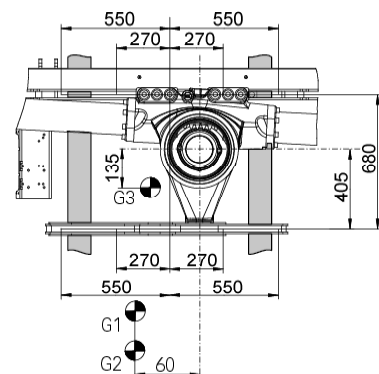

(1) Variable value depending on option.
 (2) Variations may occur depending on mounting position.

Load Diagram

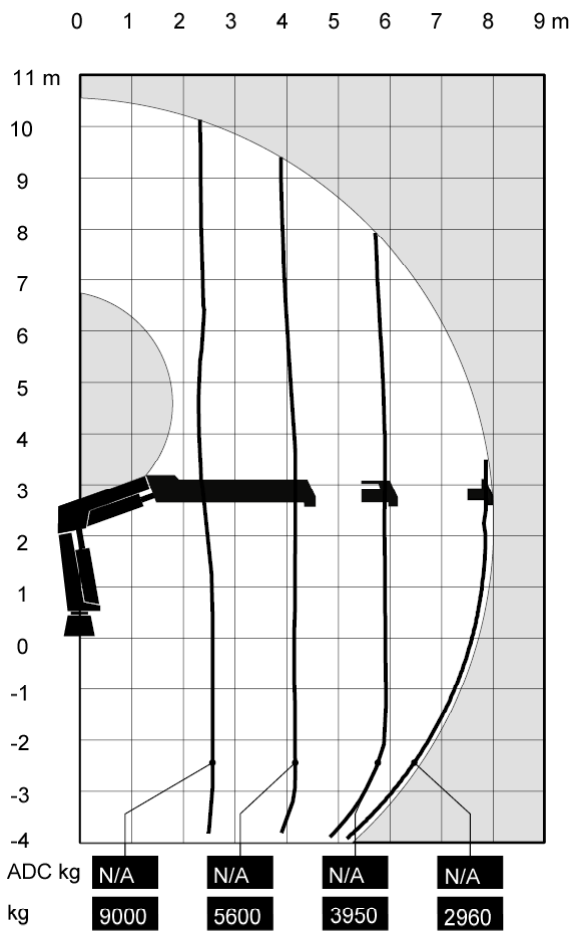

Capacity and performance

Lifting capacity	229.5 (kNm)
Standard lifting capacity at standard outreach	2.5 (m) - 9000 (kg)
	4.2 (m) - 5600 (kg)
	5.9 (m) - 3950 (kg)
	7.9 (m) - 2960 (kg)
Manual lifting capacity at extension	10.1 (m) - 2240 (kg)
	12.5 (m) - 1740 (kg)
Heavy lift capacity at heavy lift outreach	2.2 (m) - 10100 (kg)
Hydraulic boom extension	3.8 (m)
Manual max outreach	15.1 (m)
Lifting height above installation level hydraulic	10.6 (m)
Lifting height above installation level manual	15.1 (m)
Slewing torque	34 (kNm)
V80 Slewing speed	15 (°/s)
Slewing angle	420 (°)
Lifting speed	1.0 m/s

Functional demands

Recommended oil flow low	50 (l/min)
Recommended oil flow high	70 (l/min)
Working pressure	29 (MPa)
Max slope viable at full capacity	5 (°)

Weights and measurements

Height in folded position	2335 (mm)
Width in folded position	2429 (mm)
Installation space needed	1070 (mm)
Weight of crane	2600 (kg)
Weight support leg equipment	402 (kg)

Side View Unfolded Close in Area

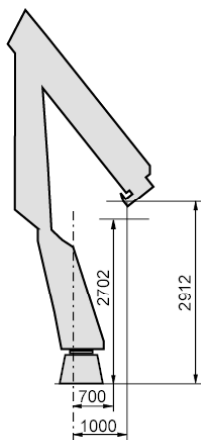

Side View Unfolded Stretched

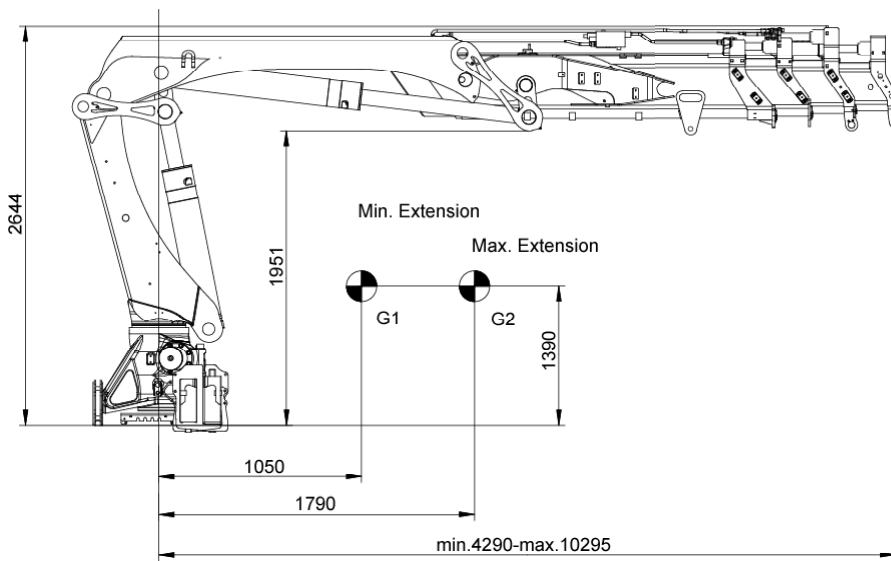

Side View Folded

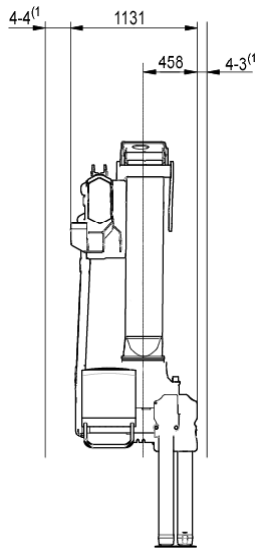

Front View Folded

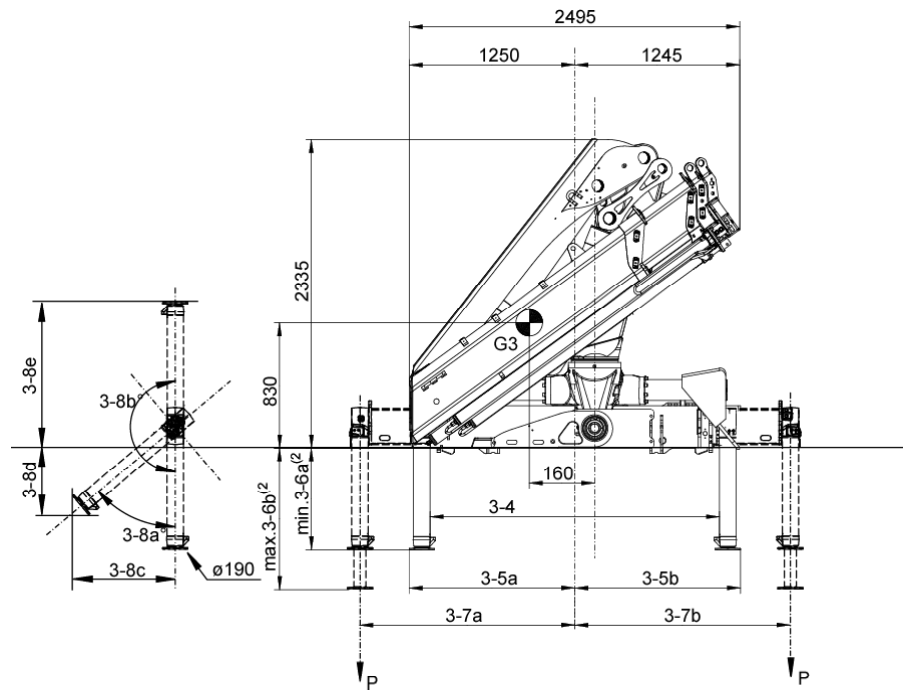

NOTE For specific values, see Table of Measurements

Top View Crane Base

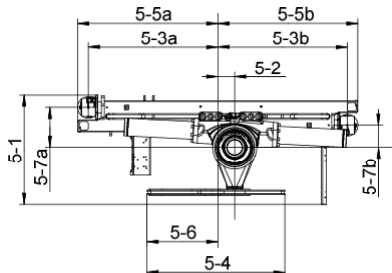

NOTE For specific values, see Table of Measurements

Chassis Installation

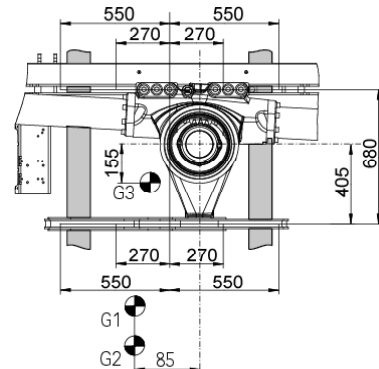

Load Diagram

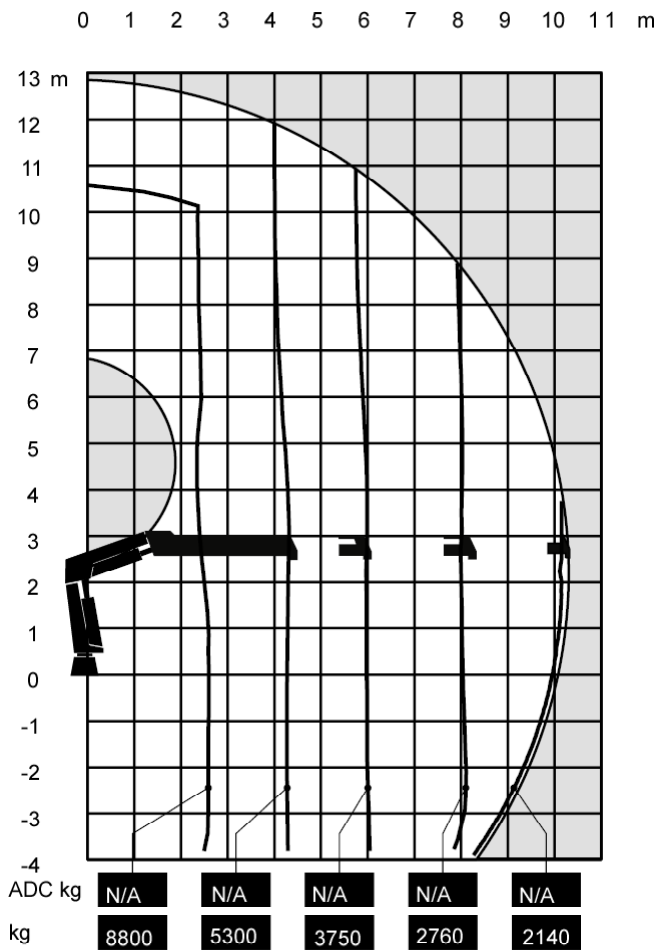

Capacity and performance

Lifting capacity	223.8 (kNm)
Standard lifting capacity at standard outreach	2.5 (m) - 8800 (kg)
	4.3 (m) - 5300 (kg)
	6.0 (m) - 3750 (kg)
	8.0 (m) - 2760 (kg)
	10.2 (m) - 2140 (kg)
Manual lifting capacity at extension	12.5 (m) - 1680 (kg)
	14.9 (m) - 1340 (kg)
Heavy lift capacity at heavy lift outreach	2.2 (m) - 9900 (kg)
Hydraulic boom extension	6.0 (m)
Manual max outreach	17.4 (m)
Lifting height above installation level hydraulic	12.9 (m)
Lifting height above installation level manual	17.5 (m)
Slewing torque	34 (kNm)
V80 Slewing speed	15 (°/s)
Slewing angle	420 (°)
Lifting speed	1.2 m/s

Functional demands

Recommended oil flow low	50 (l/min)
Recommended oil flow high	70 (l/min)
Working pressure	29 (MPa)
Max slope viable at full capacity	5 (°)

Weights and measurements

Height in folded position	2335 (mm)
Width in folded position	2495 (mm)
Installation space needed	1131 (mm)
Weight of crane	2800 (kg)
Weight support leg equipment	402 (kg)

Side View Unfolded Close in Area

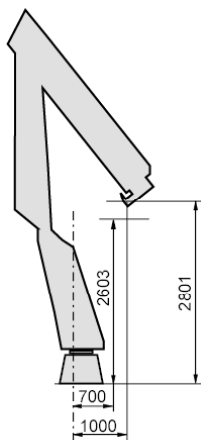

Side View Unfolded Stretched

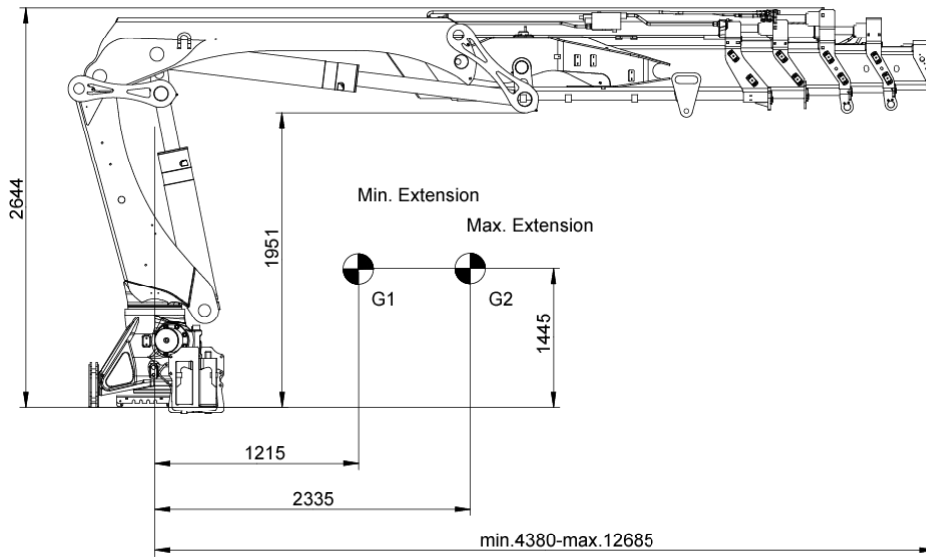

Side View Folded

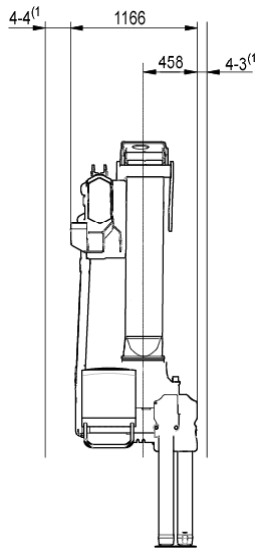

Front View Folded

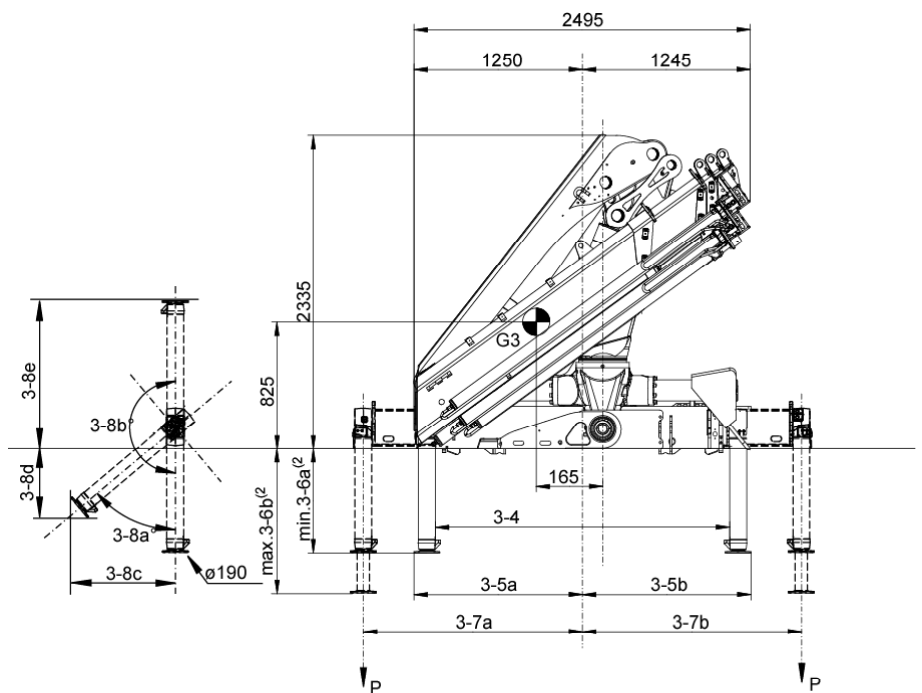

NOTE For specific values, see Table of Measurements

Top View Crane Base

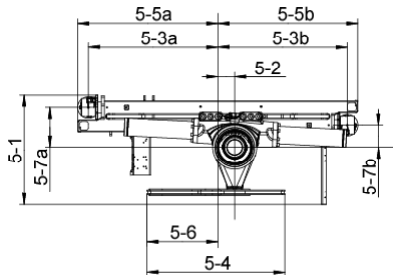

NOTE For specific values, see Table of Measurements

Chassis Installation

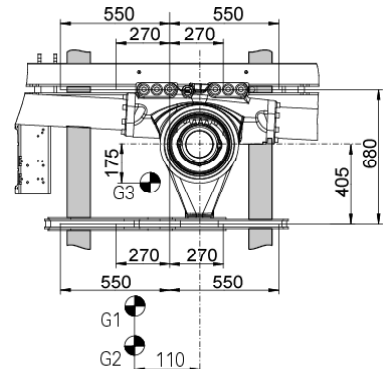

(1) Variable value depending on option.
 (2) Variations may occur depending on mounting position.

Load Diagram

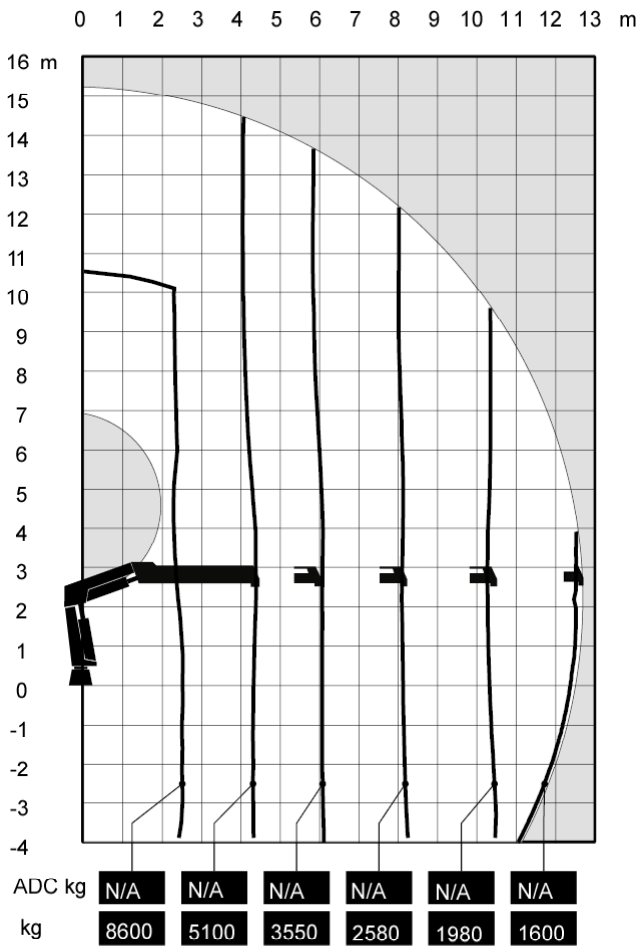

Capacity and performance

Lifting capacity	218.7 (kNm)	
Standard lifting capacity at standard outreach	2.5 (m)	- 8600 (kg)
	4.4 (m)	- 5100 (kg)
	6.1 (m)	- 3550 (kg)
	8.1 (m)	- 2580 (kg)
	10.3 (m)	- 1980 (kg)
Manual lifting capacity at extension	12.6 (m)	- 1600 (kg)
	15.0 (m)	- 1240 (kg)
Heavy lift capacity at heavy lift outreach	17.2 (m)	- 1040 (kg)
	2.2 (m)	- 9700 (kg)
Hydraulic boom extension	8.3 (m)	
Manual max outreach	17.4 (m)	
Lifting height above installation level hydraulic	15.3 (m)	
Lifting height above installation level manual	19.8 (m)	
Slewing torque	34 (kNm)	
V80 Slewing speed	15 (°/s)	
Slewing angle	420 (°)	
Lifting speed	1.5 m/s	

Functional demands

Recommended oil flow low	50 (l/min)
Recommended oil flow high	70 (l/min)
Working pressure	29 (MPa)
Max slope viable at full capacity	5 (°)

Weights and measurements

Height in folded position	2335 (mm)
Width in folded position	2495 (mm)
Installation space needed	1166 (mm)
Weight of crane	2970 (kg)
Weight support leg equipment	402 (kg)

Side View Unfolded Close in Area

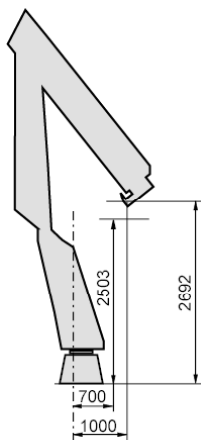

Side View Unfolded Stretched

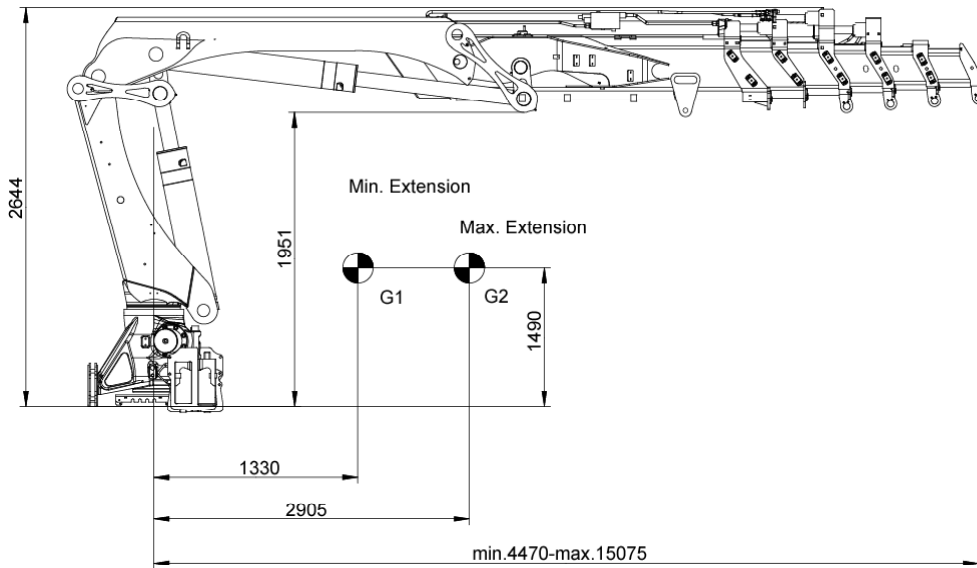

Side View Folded

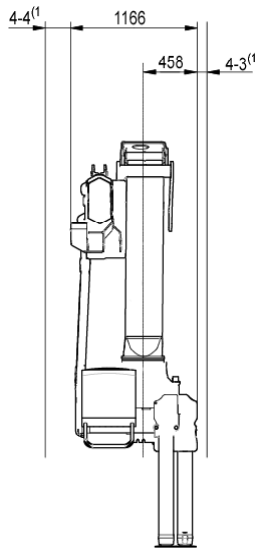

Front View Folded

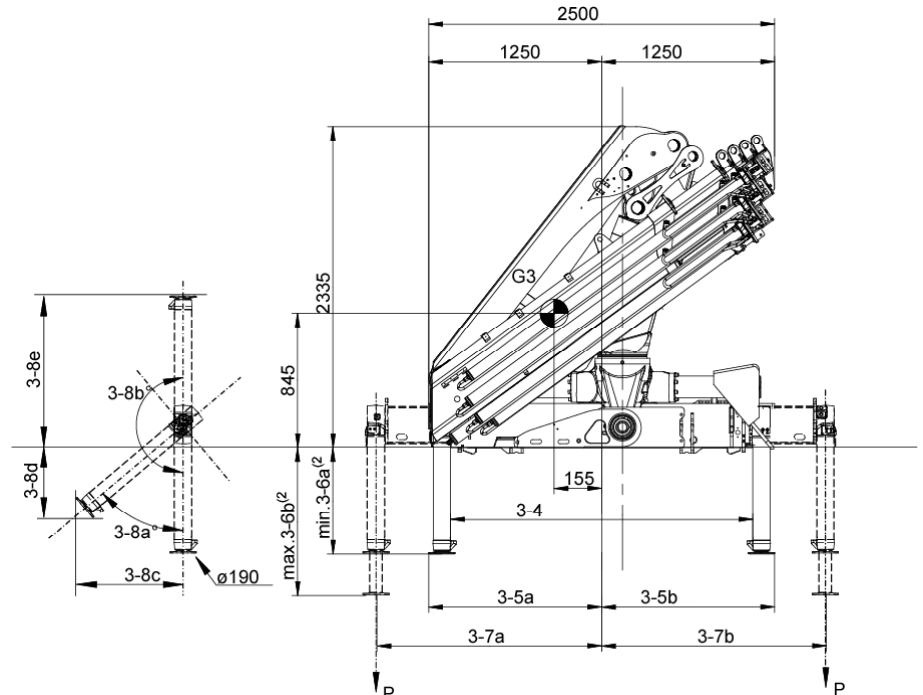

NOTE For specific values, see Table of Measurements

Top View Crane Base

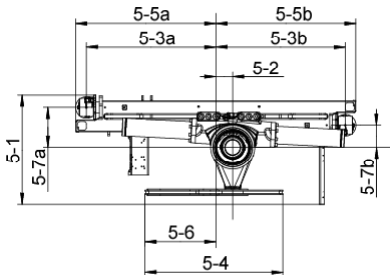

NOTE For specific values, see Table of Measurements

Chassis Installation

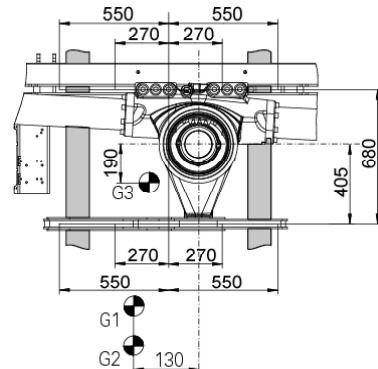

Load Diagram

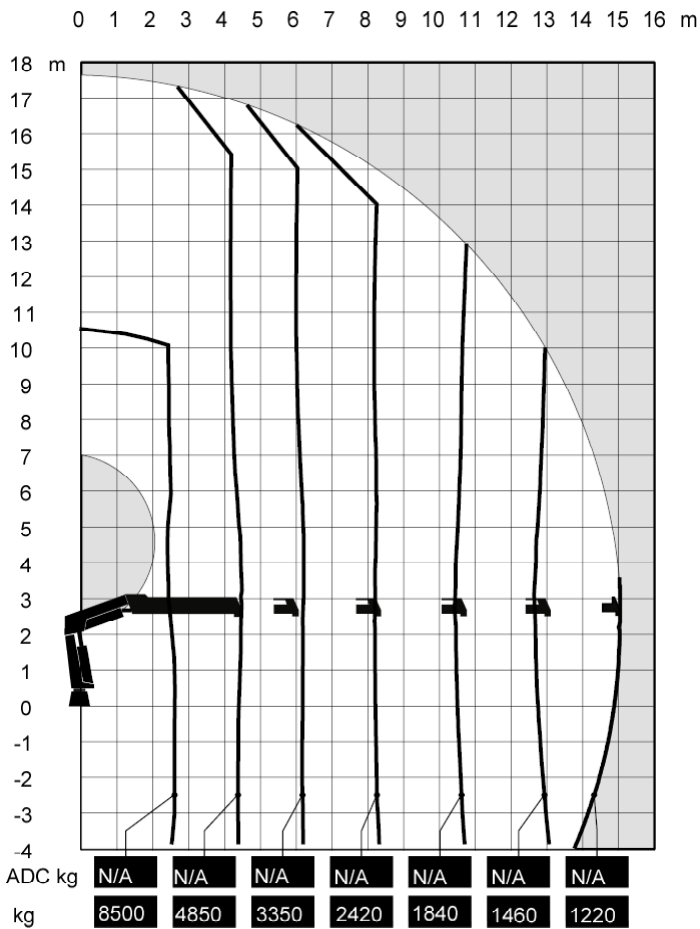

Capacity and performance

Lifting capacity	214.5 (kNm)	
Standard lifting capacity at standard outreach	2.5 (m)	- 8500 (kg)
	4.5 (m)	- 4850 (kg)
	6.2 (m)	- 3350 (kg)
	8.2 (m)	- 2420 (kg)
	10.4 (m)	- 1840 (kg)
Manual lifting capacity at extension	12.7 (m)	- 1460 (kg)
	15.0 (m)	- 1220 (kg)
Heavy lift capacity at heavy lift outreach	17.2 (m)	- 1000 (kg)
Hydraulic boom extension	10.6 (m)	
Manual max outreach	17.4 (m)	
Lifting height above installation level hydraulic	17.7 (m)	
Lifting height above installation level manual	19.8 (m)	
Slewing torque	34 (kNm)	
V80 Slewing speed	15 (°/s)	
Slewing angle	420 (°)	
Lifting speed	1.8 (m/s)	

Functional demands

Recommended oil flow low	50 (l/min)
Recommended oil flow high	70 (l/min)
Working pressure	29 (MPa)
Max slope viable at full capacity	5 (°)

Weights and measurements

Height in folded position	2335 (mm)
Width in folded position	2500 (mm)
Installation space needed	1166 (mm)
Weight of crane	3110 (kg)
Weight support leg equipment	402 (kg)

Side View Unfolded Close in Area

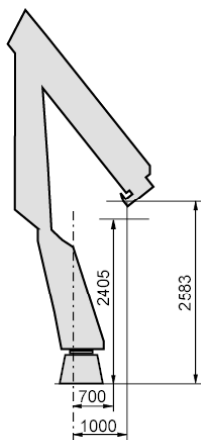

Side View Unfolded Stretched

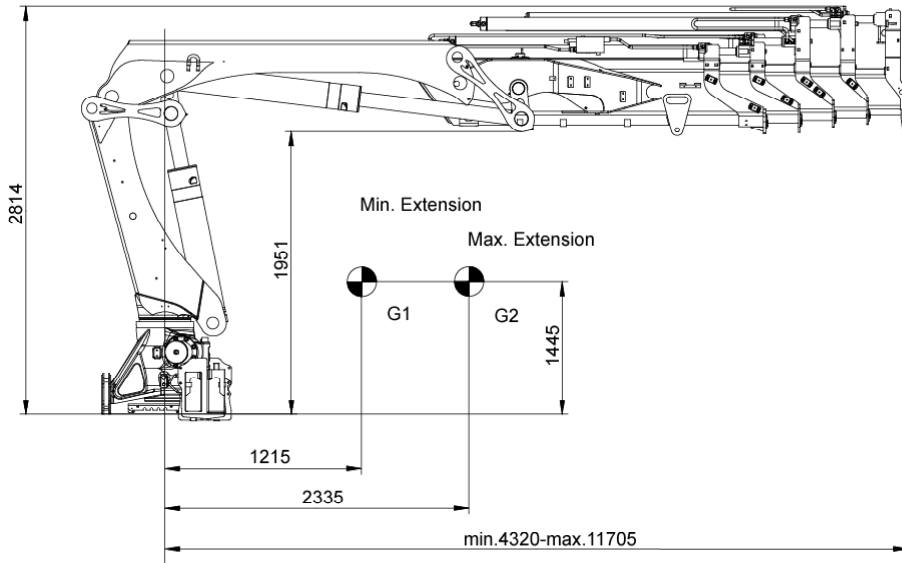

Side View Folded

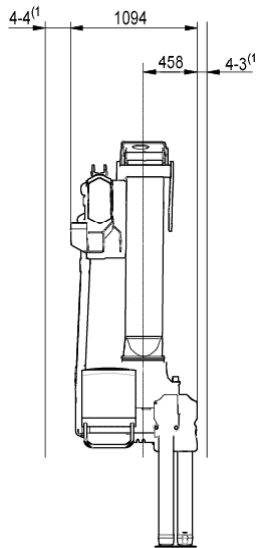

Front View Folded

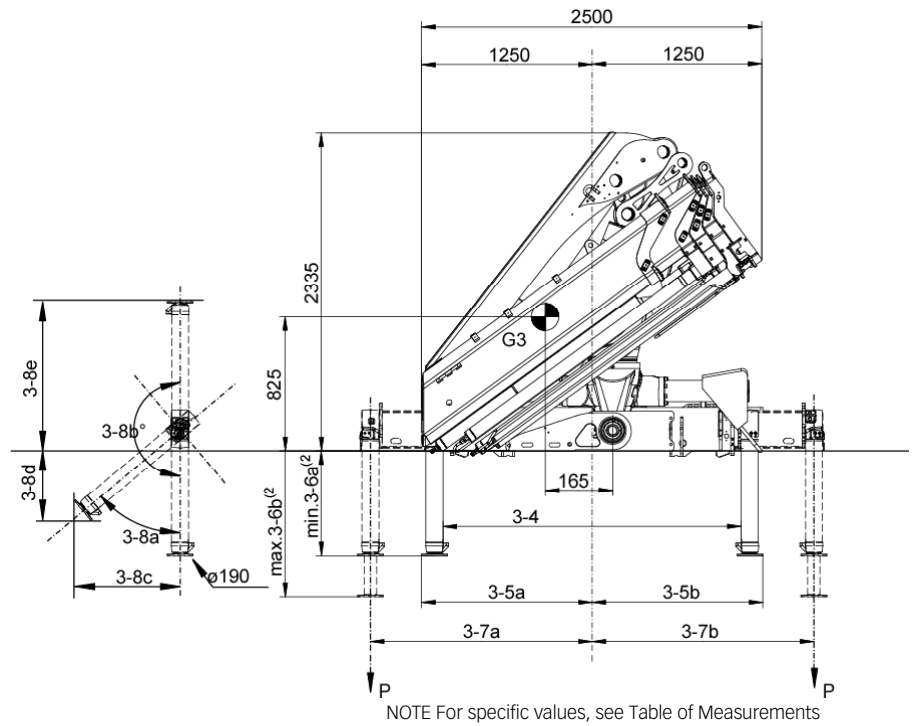

Top View Crane Base

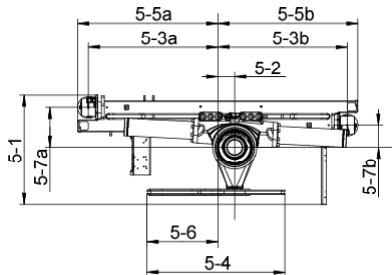

NOTE For specific values, see Table of Measurements

Chassis Installation

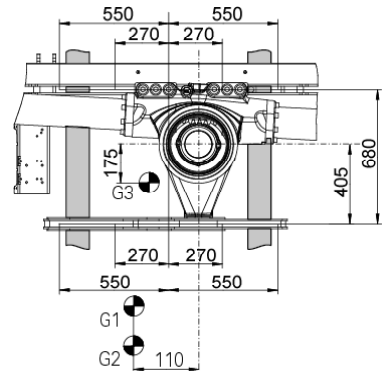

(1) Variable value depending on option.
 (2) Variations may occur depending on mounting position.

Load Diagram

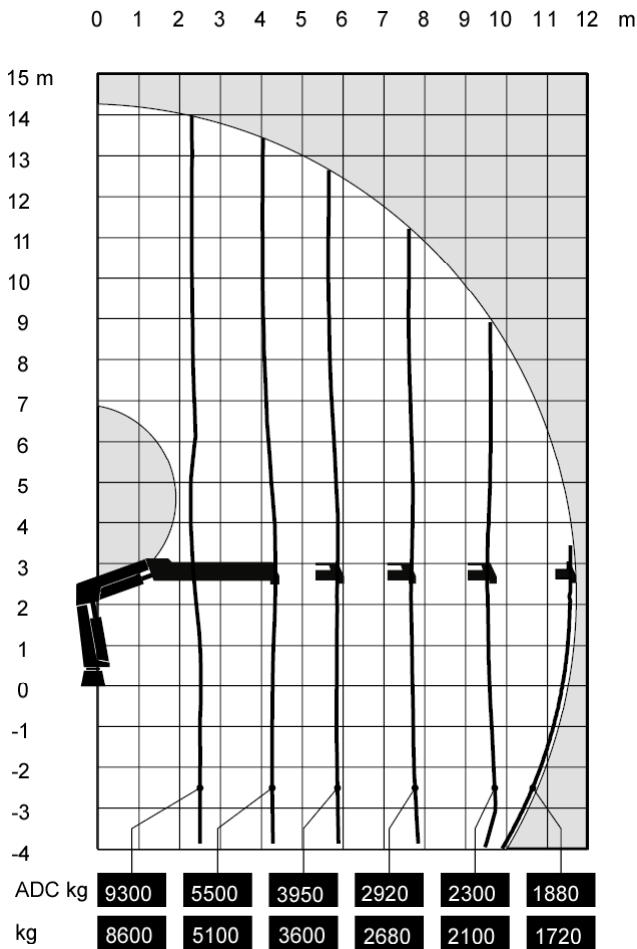

Side View Unfolded Close in Area

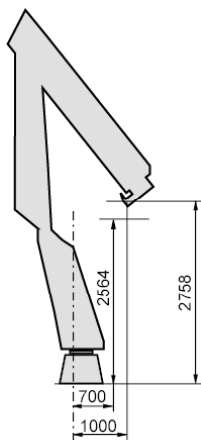

Capacity and performance

Lifting capacity with ADC	234.5 (kNm)
Lifting capacity	216.6 (kNm)
Standard lifting capacity at standard outreach with ADC	2.5 (m) - 9300 (kg)
	4.3 (m) - 5500 (kg)
	5.9 (m) - 3950 (kg)
	7.7 (m) - 2920 (kg)
	9.6 (m) - 2300 (kg)
	11.6 (m) - 1880 (kg)
Standard lifting capacity at standard outreach	2.5 (m) - 8600 (kg)
	4.3 (m) - 5100 (kg)
	5.9 (m) - 3600 (kg)
	7.7 (m) - 2680 (kg)
	9.6 (m) - 2100 (kg)
	11.6 (m) - 1720 (kg)
Manual lifting capacity at extension	13.7 (m) - 1520 (kg)
	15.9 (m) - 1240 (kg)
Heavy lift capacity at heavy lift outreach	2.2 (m) - 10400 (kg)
Hydraulic boom extension	7.4 (m)
Manual max outreach	18.6 (m)
Lifting height above installation level hydraulic	14.3 (m)
Lifting height above installation level manual	18.5 (m)
Slewing torque	34 (kNm)
V80 Slewing speed	15 (°/s)
Slewing angle	420 (°)
Lifting speed	1.4 (m/s)

Functional demands

Recommended oil flow low	50 (l/min)
Recommended oil flow high	70 (l/min)
Working pressure	31 (MPa)
Max slope viable at full capacity	5 (°)

Weights and measurements

Height in folded position	2335 (mm)
Width in folded position	2500 (mm)
Installation space needed	1094 (mm)
Weight of crane	3060 (kg)
Weight support leg equipment	402 (kg)

Side View Unfolded Stretched

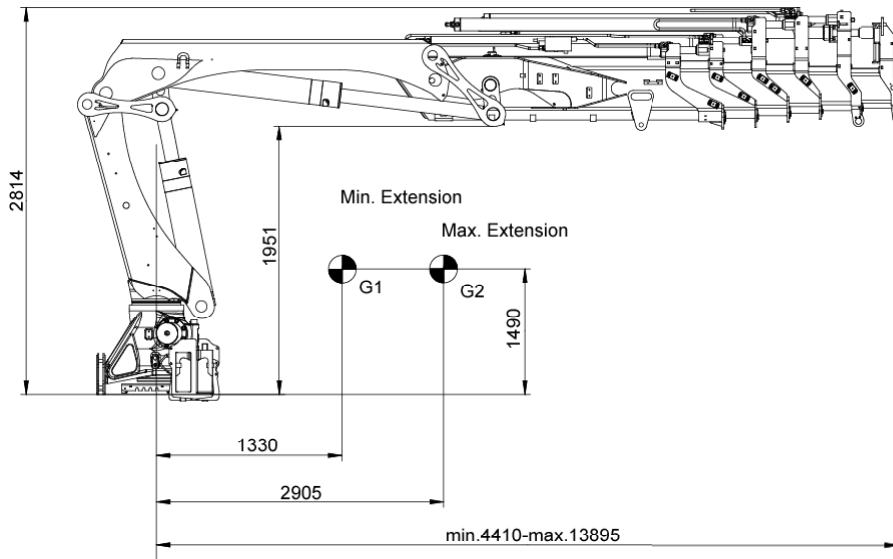

Side View Folded

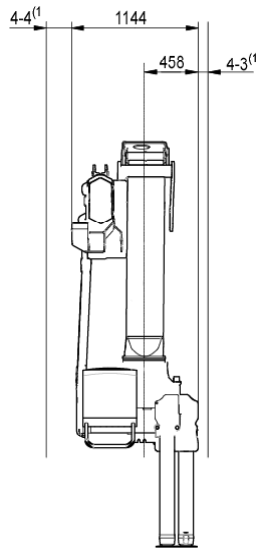

Front View Folded

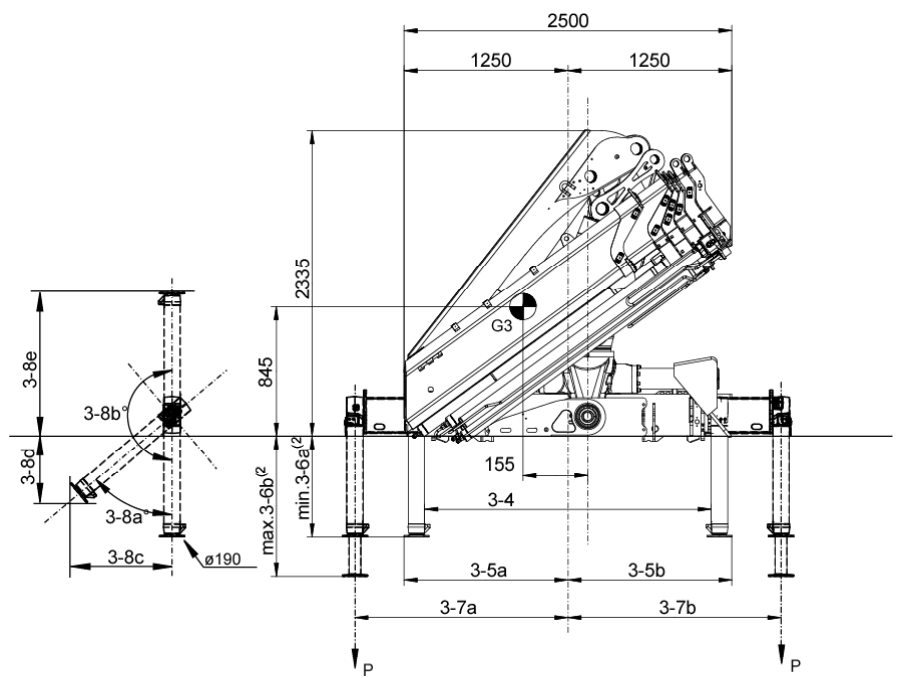

NOTE For specific values, see Table of Measurements

Top View Crane Base

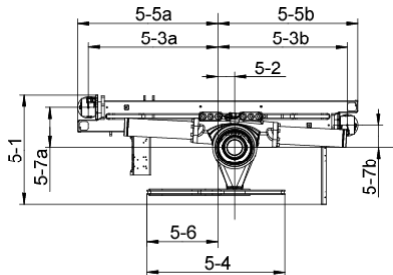

NOTE For specific values, see Table of Measurements

Chassis Installation

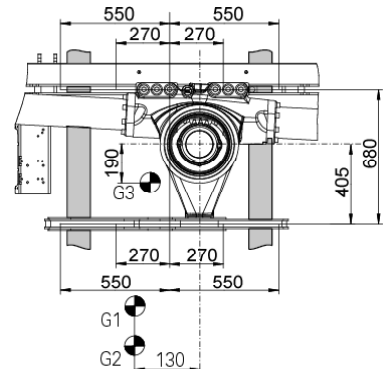

Load Diagram

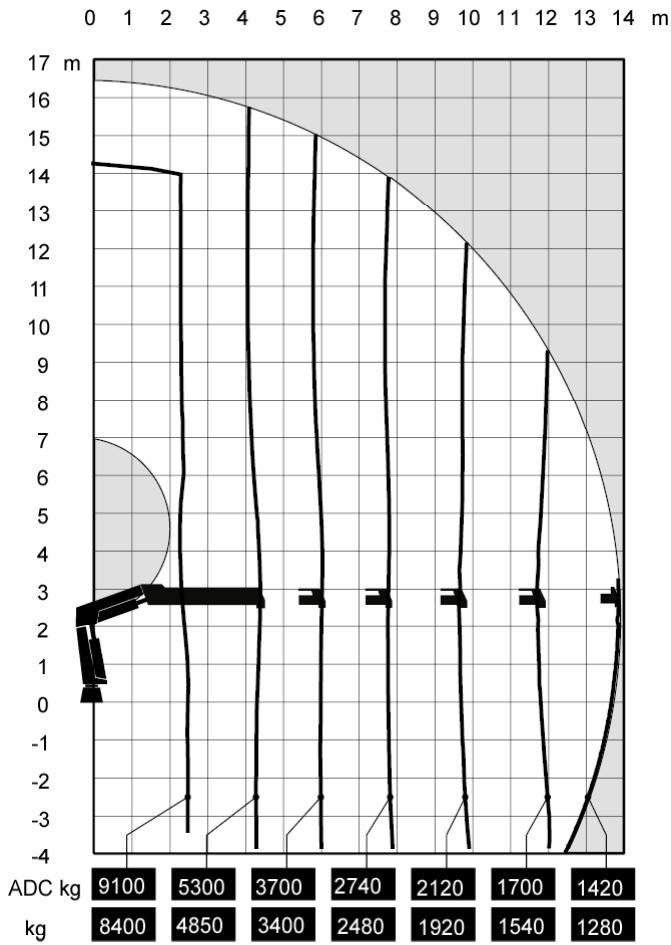

Capacity and performance

Lifting capacity with ADC	228.8 (kNm)
Lifting capacity	210.9 (kNm)
Standard lifting capacity at standard outreach with ADC	2.5 (m) - 9100 (kg) 4.4 (m) - 5300 (kg) 6.0 (m) - 3700 (kg) 7.8 (m) - 2740 (kg) 9.7 (m) - 2120 (kg) 11.7 (m) - 1700 (kg) 13.8 (m) - 1420 (kg)
Standard lifting capacity at standard outreach	2.5 (m) - 8400 (kg) 4.4 (m) - 4850 (kg) 6.0 (m) - 3400 (kg) 7.8 (m) - 2480 (kg) 9.7 (m) - 1920 (kg) 11.7 (m) - 1540 (kg) 13.8 (m) - 1280 (kg)
Manual lifting capacity at extension	15.8 (m) - 1180 (kg) 17.5 (m) - 1000 (kg)
Heavy lift capacity at heavy lift outreach	2.2 (m) - 10200 (kg)
Hydraulic boom extension	9.5 (m)
Manual max outreach	21.0 (m)
Lifting height above installation level hydraulic	16.5 (m)
Lifting height above installation level manual	20.1 (m)
Slewing torque	34 (kNm)
V80 Slewing speed	15 (°/s)
Slewing angle	420 (°)
Lifting speed	1.7 m/s

Functional demands

Recommended oil flow low	50 (l/min)
Recommended oil flow high	70 (l/min)
Working pressure	31 (MPa)
Max slope viable at full capacity	5 (°)

Weights and measurements

Height in folded position	2335 (mm)
Width in folded position	2500 (mm)
Installation space needed	1144 (mm)
Weight of crane	3240 (kg)
Weight support leg equipment	402 (kg)

Side View Unfolded Close in Area

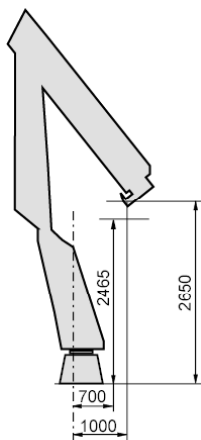

Side View Unfolded Stretched

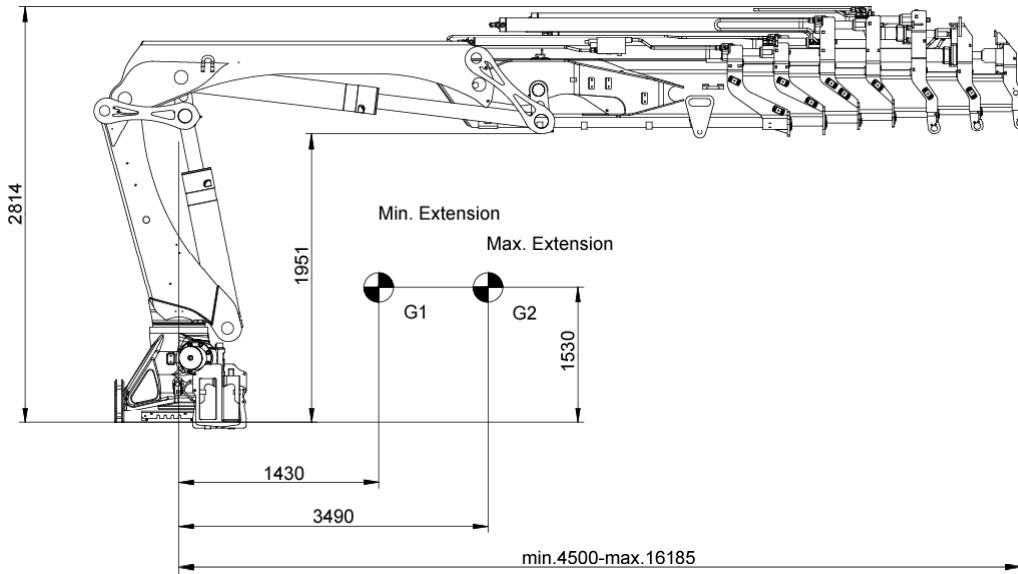

Side View Folded

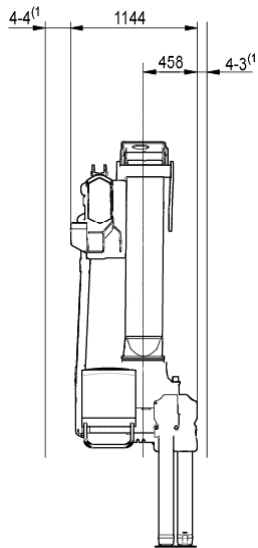

Front View Folded

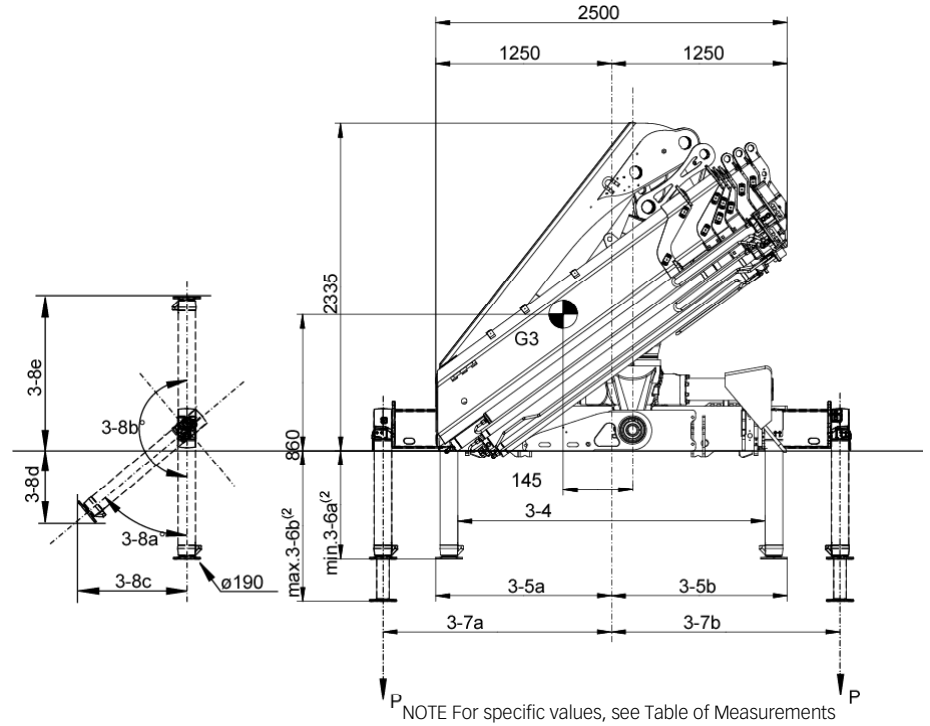

Top View Crane Base

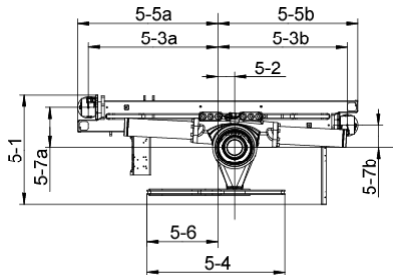

NOTE For specific values, see Table of Measurements

Chassis Installation

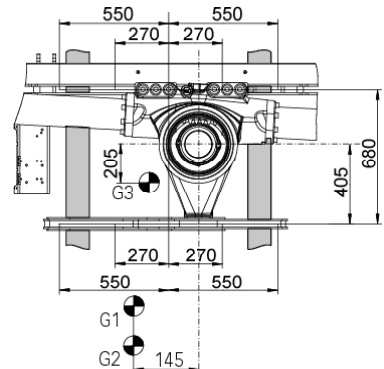

Load Diagram

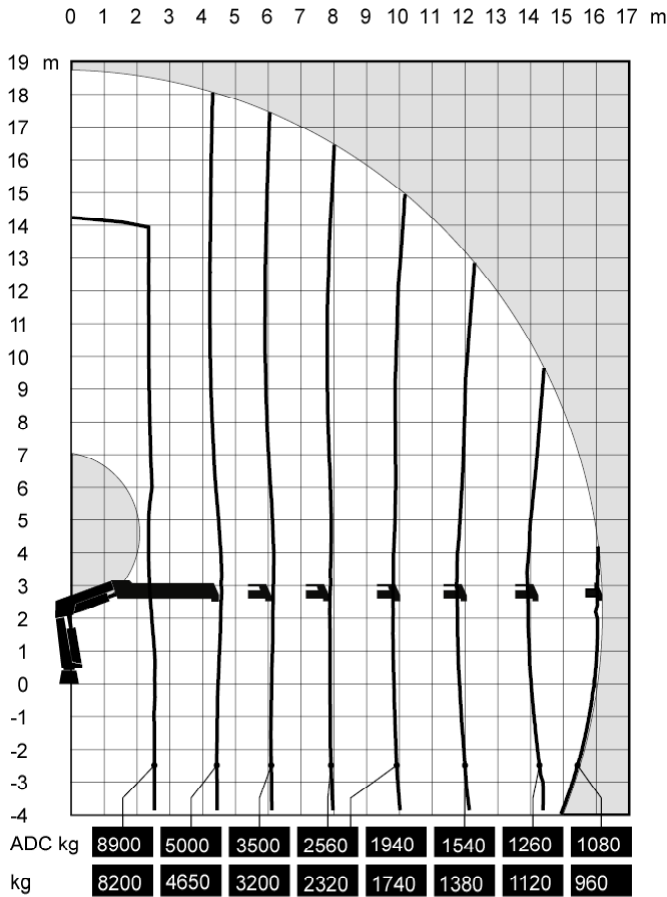

Capacity and performance

Lifting capacity with ADC	223.4 (kNm)
Lifting capacity	205.4 (kNm)
Standard lifting capacity at standard outreach with ADC	2.5 (m) - 8900 (kg) 4.5 (m) - 5000 (kg) 6.1 (m) - 3500 (kg) 7.9 (m) - 2560 (kg) 9.8 (m) - 1940 (kg) 11.8 (m) - 1540 (kg) 13.9 (m) - 1260 (kg) 16.1 (m) - 1080 (kg)
Standard lifting capacity at standard outreach	2.5 (m) - 8200 (kg) 4.5 (m) - 4650 (kg) 6.1 (m) - 3200 (kg) 7.9 (m) - 2320 (kg) 9.8 (m) - 1740 (kg) 11.8 (m) - 1380 (kg) 13.9 (m) - 1120 (kg) 16.1 (m) - 960 (kg)
Manual lifting capacity at extension	18.3 (m) - 860 (kg) 20.4 (m) - 720 (kg)
Heavy lift capacity at heavy lift outreach	2.2 (m) - 10000 (kg)
Hydraulic boom extension	11.7 (m)
Manual max outreach	23.3 (m)
Lifting height above installation level hydraulic	18.8 (m)
Lifting height above installation level manual	23.1 (m)
Slewing torque	34 (kNm)
V80 Slewing speed	15 (°/s)
Slewing angle	420 (°)
Lifting speed	1.9 m/s

Side View Unfolded Close in Area

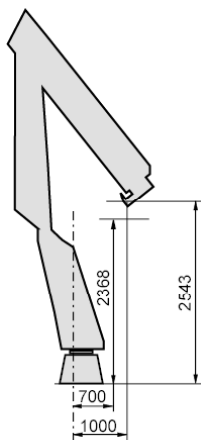

Functional demands

Recommended oil flow low	50 (l/min)
Recommended oil flow high	70 (l/min)
Working pressure	31 (MPa)
Max slope viable at full capacity	5 (°)

Weights and measurements

Height in folded position	2335 (mm)
Width in folded position	2500 (mm)
Installation space needed	1144 (mm)
Weight of crane	3410 (kg)
Weight support leg equipment	402 (kg)

Side View Unfolded Stretched

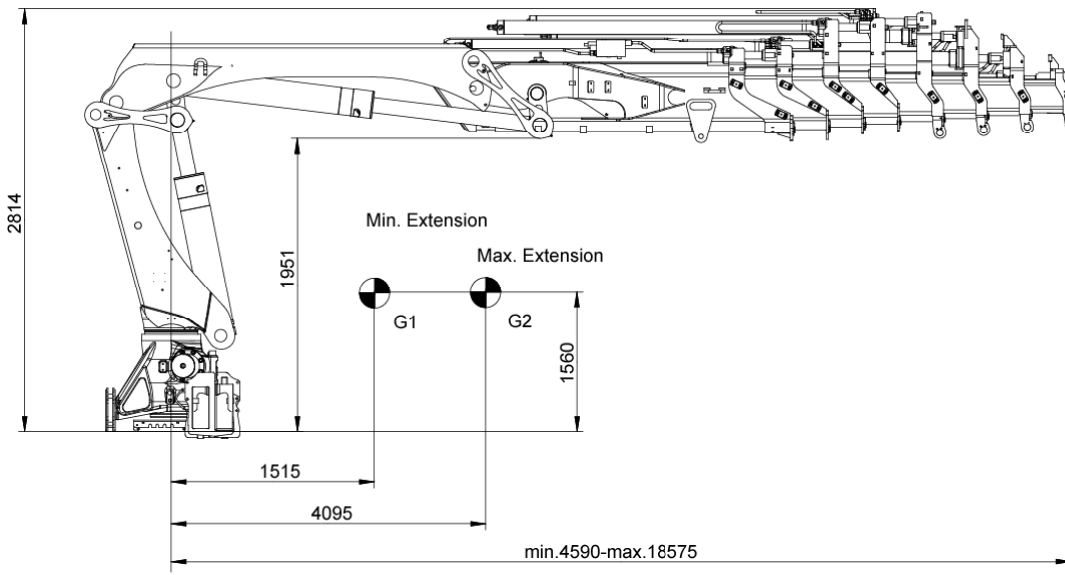

Side View Folded

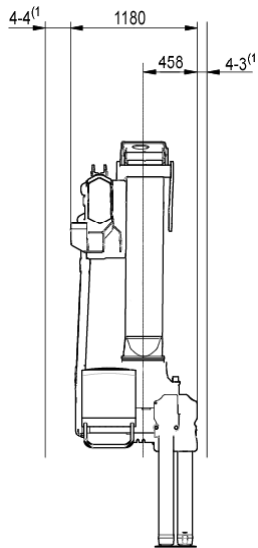

Front View Folded

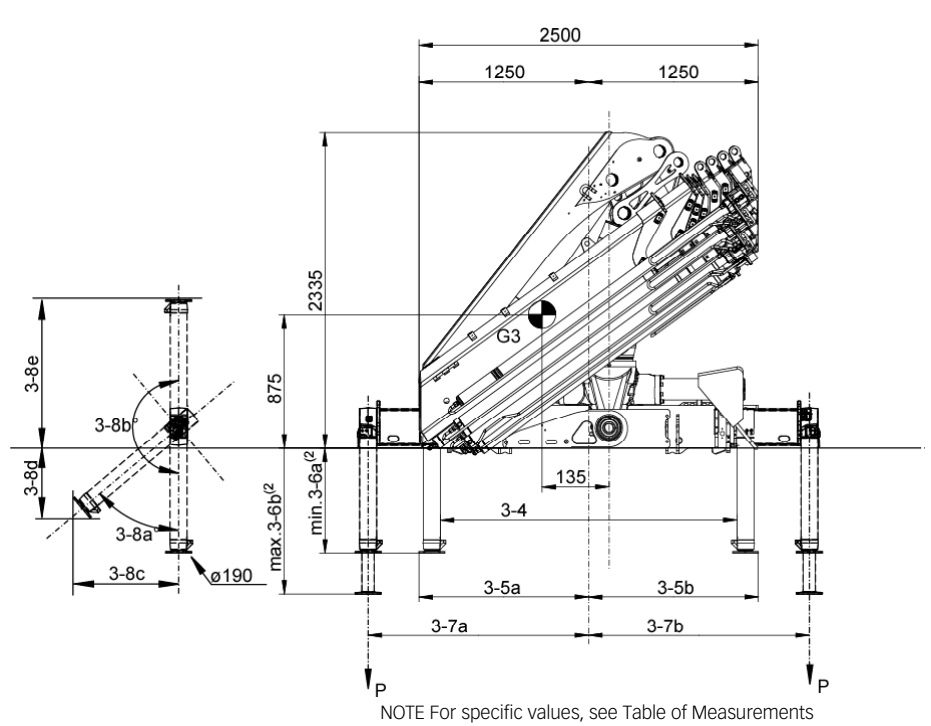

Top View Crane Base

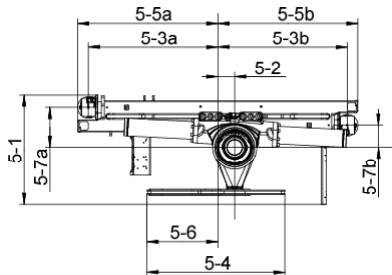

NOTE For specific values, see Table of Measurements

Chassis Installation

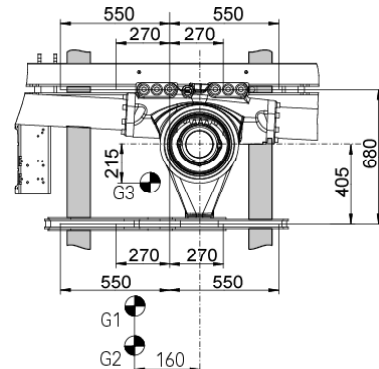

(1) Variable value depending on option.
 (2) Variations may occur depending on mounting position.

Load Diagram

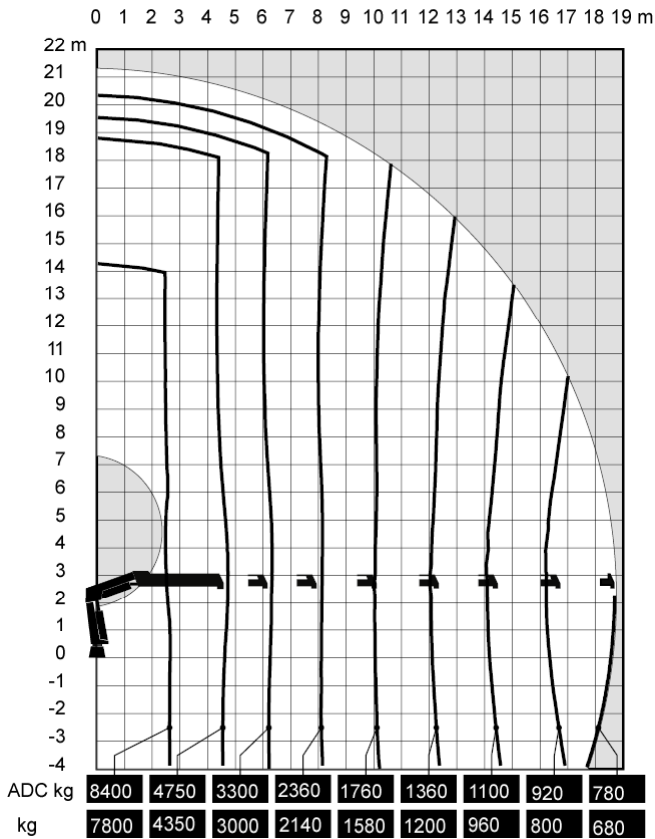

Side View Unfolded Close in Area

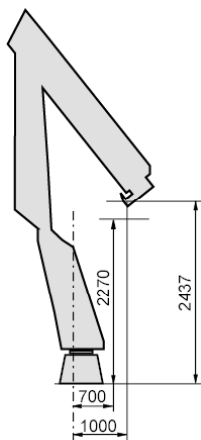

Capacity and performance

Lifting capacity with ADC	219.5 (kNm)
Lifting capacity	201.4 (kNm)
Standard lifting capacity at standard outreach with ADC	2.6 (m) - 8400 (kg)
	4.7 (m) - 4750 (kg)
	6.3 (m) - 3300 (kg)
	8.1 (m) - 2360 (kg)
	10.0 (m) - 1760 (kg)
	12.0 (m) - 1360 (kg)
	14.1 (m) - 1100 (kg)
	16.3 (m) - 920 (kg)
	18.6 (m) - 780 (kg)
Standard lifting capacity at standard outreach	2.6 (m) - 7800 (kg)
	4.7 (m) - 4350 (kg)
	6.3 (m) - 3000 (kg)
	8.1 (m) - 2140 (kg)
	10.0 (m) - 1580 (kg)
	12.0 (m) - 1200 (kg)
	14.1 (m) - 960 (kg)
	16.3 (m) - 800 (kg)
	18.6 (m) - 680 (kg)
Manual lifting capacity at extension	20.1 (m) - 660 (kg)
	21.6 (m) - 560 (kg)
Heavy lift capacity at heavy lift outreach	2.2 (m) - 9800 (kg)
Hydraulic boom extension	14.0 (m)
Manual max outreach	23.2 (m)
Lifting height above installation level hydraulic	21.2 (m)
Lifting height above installation level manual	24.2 (m)
Slewing torque	34 (kNm)
V80 Slewing speed	15 (°/s)
Slewing angle	420 (°)
Lifting speed	2.2 (m/s)

Functional demands

Recommended oil flow low	50 (l/min)
Recommended oil flow high	70 (l/min)
Working pressure	31 (MPa)
Max slope viable at full capacity	5 (°)

Weights and measurements

Height in folded position	2335 (mm)
Width in folded position	2500 (mm)
Installation space needed	1180 (mm)
Weight of crane	3570 (kg)
Weight support leg equipment	402 (kg)

Side View Unfolded Stretched

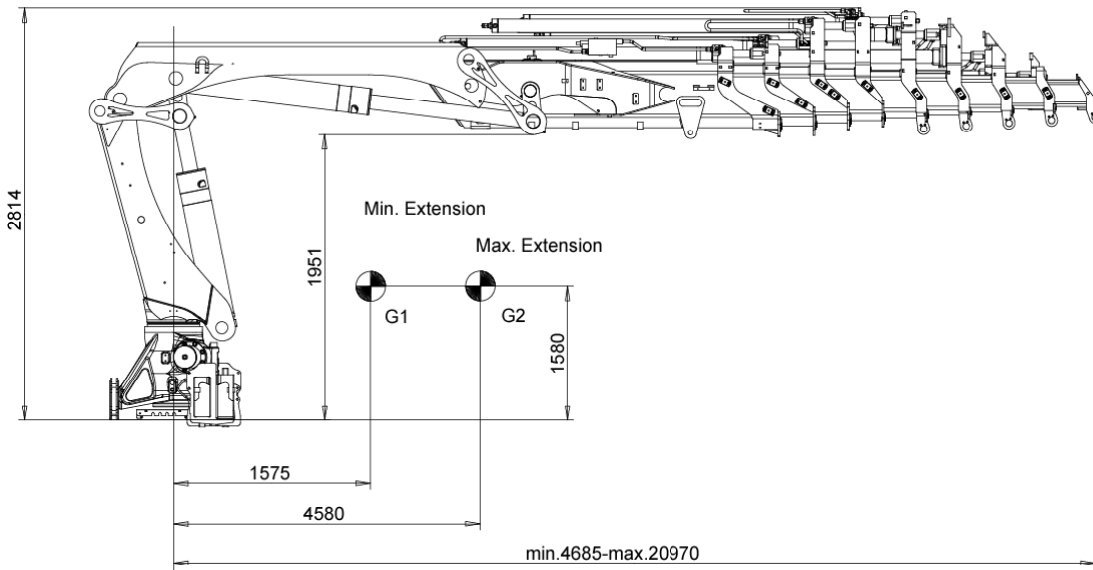

Side View Folded

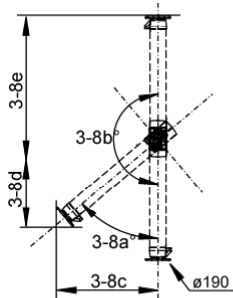
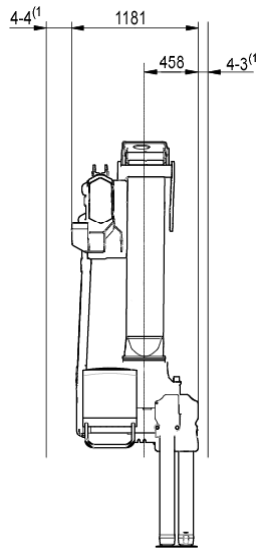

Front View Folded

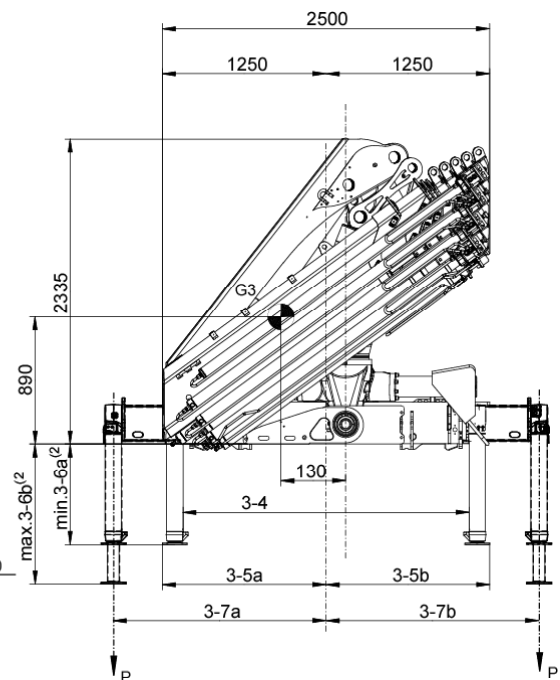

NOTE For specific values, see Table of Measurements

Top View Crane Base

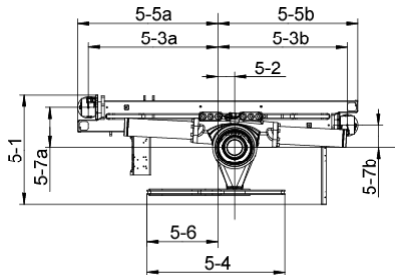

NOTE For specific values, see Table of Measurements

Chassis Installation

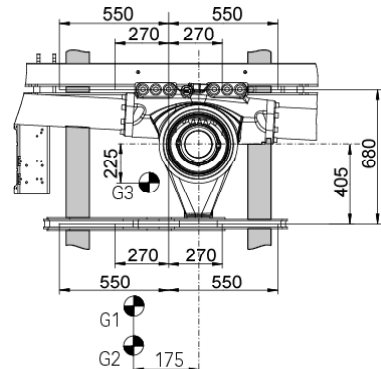

Load Diagram

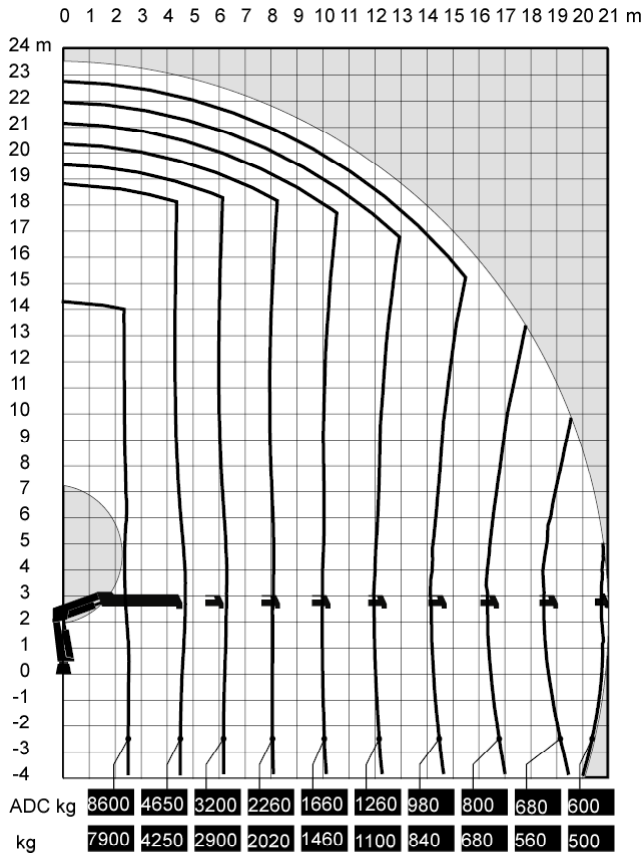

Side View Unfolded Close in Area

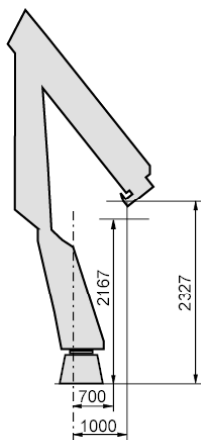

Capacity and performance

Lifting capacity with ADC	214.3 (kNm)
Lifting capacity	196.2 (kNm)
Standard lifting capacity at standard outreach with ADC	2.5 (m) - 8600 (kg) 4.7 (m) - 4650 (kg) 6.3 (m) - 3200 (kg) 8.1 (m) - 2260 (kg) 10.0 (m) - 1660 (kg) 12.0 (m) - 1260 (kg) 14.1 (m) - 980 (kg) 16.3 (m) - 800 (kg) 18.6 (m) - 680 (kg) 20.9 (m) - 600 (kg)
Standard lifting capacity at standard outreach	2.5 (m) - 7900 (kg) 4.7 (m) - 4250 (kg) 6.3 (m) - 2900 (kg) 8.1 (m) - 2020 (kg) 10.0 (m) - 1460 (kg) 12.0 (m) - 1100 (kg) 14.1 (m) - 840 (kg) 16.3 (m) - 680 (kg) 18.6 (m) - 560 (kg) 20.9 (m) - 500 (kg)
Manual lifting capacity at extension	22.4 (m) - 490 (kg)
Heavy lift capacity at heavy lift outreach	2.2 (m) - 9700 (kg)
Hydraulic boom extension	16.3 (m)
Manual max outreach	23.3 (m)
Lifting height above installation level hydraulic	23.6 (m)
Lifting height above installation level manual	25.1 (m)
Slewing torque	34 (kNm)
V80 Slewing speed	15 (°/s)
Slewing angle	420 (°)
Lifting speed	2.5 m/s

Functional demands

Recommended oil flow low	50 (l/min)
Recommended oil flow high	70 (l/min)
Working pressure	31 (MPa)
Max slope viable at full capacity	5 (°)

Weights and measurements

Height in folded position	2335 (mm)
Width in folded position	2500 (mm)
Installation space needed	1181 (mm)
Weight of crane	3690 (kg)
Weight support leg equipment	402 (kg)

Side View Unfolded Stretched

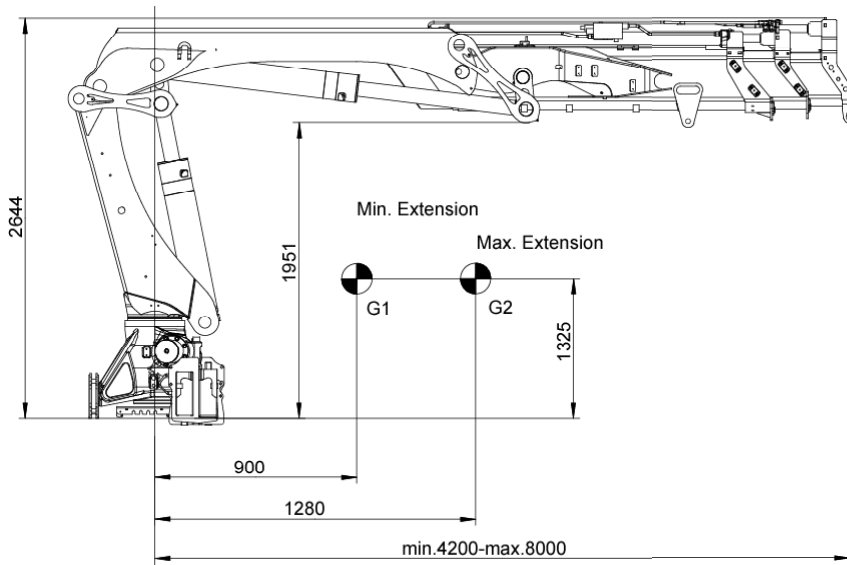

Side View Folded

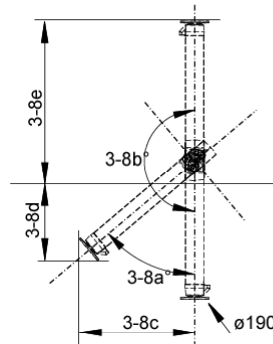
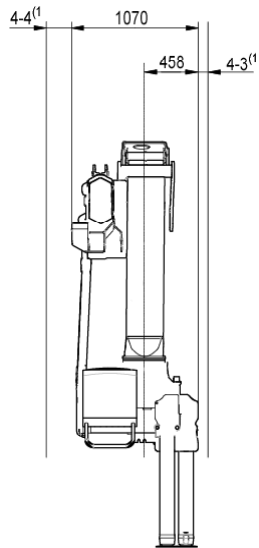

Front View Folded

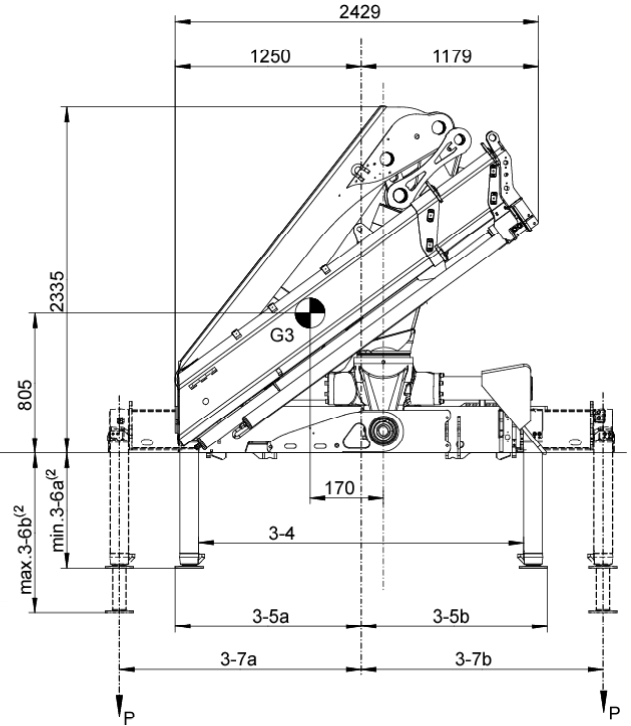

NOTE For specific values, see Table of Measurements

Top View Crane Base

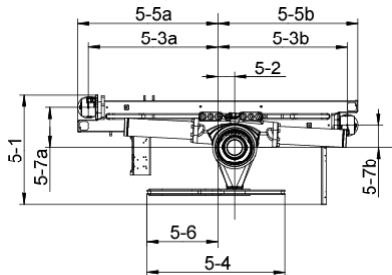

NOTE For specific values, see Table of Measurements

Chassis Installation

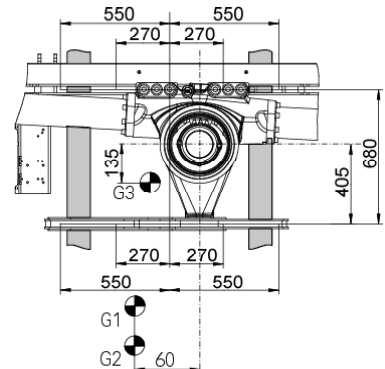

(1) Variable value depending on option.
 (2) Variations may occur depending on mounting position.

Load Diagram

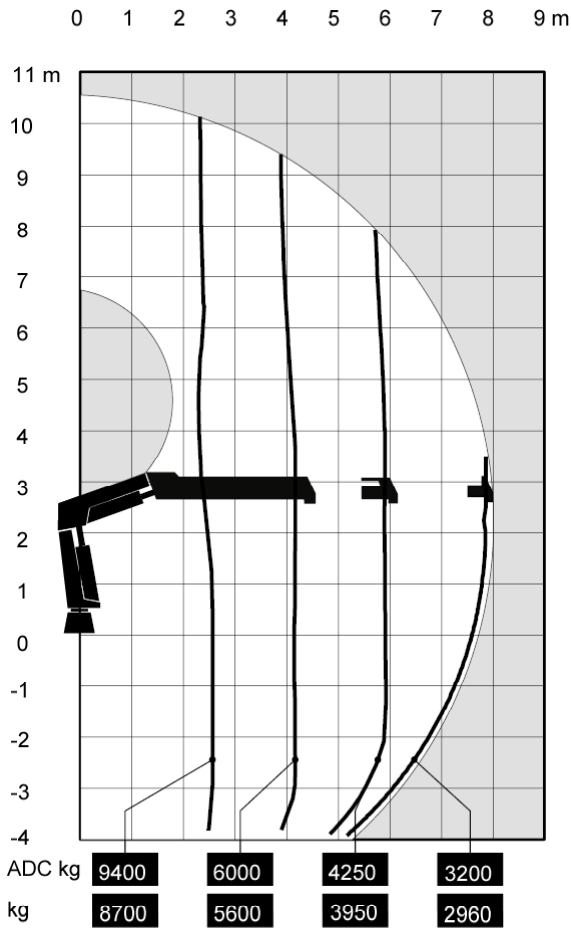

Capacity and performance

Lifting capacity with ADC	247.8 (kNm)
Lifting capacity	229.5 (kNm)
Standard lifting capacity at standard outreach with ADC	2.6 (m) - 9400 (kg)
	4.2 (m) - 6000 (kg)
	5.9 (m) - 4250 (kg)
	7.9 (m) - 3200 (kg)
Standard lifting capacity at standard outreach	2.6 (m) - 8700 (kg)
	4.2 (m) - 5600 (kg)
	5.9 (m) - 3950 (kg)
	7.9 (m) - 2960 (kg)
Manual lifting capacity at extension	10.1 (m) - 2420 (kg)
	12.5 (m) - 1900 (kg)
Heavy lift capacity at heavy lift outreach	2.2 (m) - 10900 (kg)
Hydraulic boom extension	3.8 (m)
Manual max outreach	15.1 (m)
Lifting height above installation level hydraulic	10.6 (m)
Lifting height above installation level manual	15.1 (m)
Slewing torque	34 (kNm)
V80 Slewing speed	15 (°/s)
Slewing angle	420 (°)
Lifting speed	1.0 m/s

Functional demands

Recommended oil flow low	50 (l/min)
Recommended oil flow high	70 (l/min)
Working pressure	31 (MPa)
Max slope viable at full capacity	5 (°)

Weights and measurements

Height in folded position	2335 (mm)
Width in folded position	2429 (mm)
Installation space needed	1070 (mm)
Weight of crane	2630 (kg)
Weight support leg equipment	402 (kg)

Side View Unfolded Close in Area

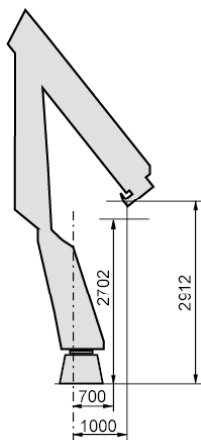

Side View Unfolded Stretched

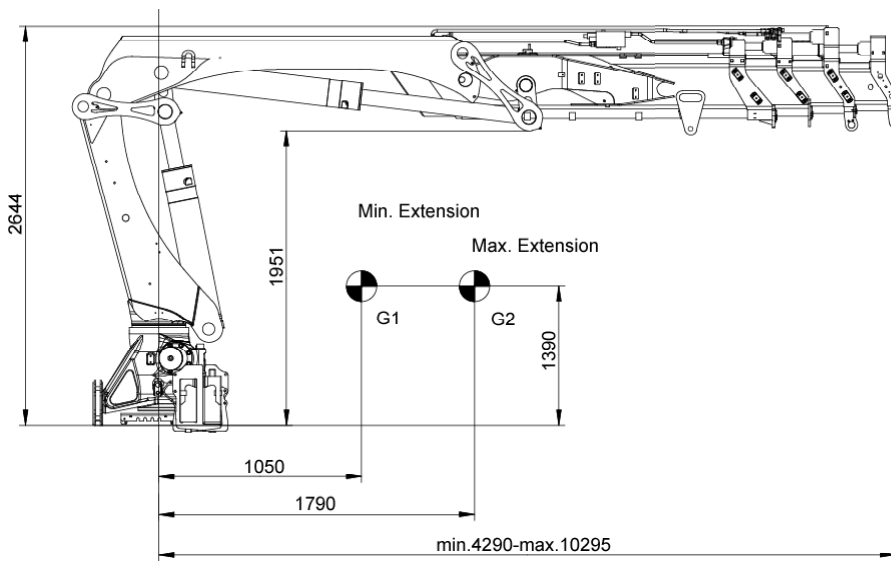

Side View Folded

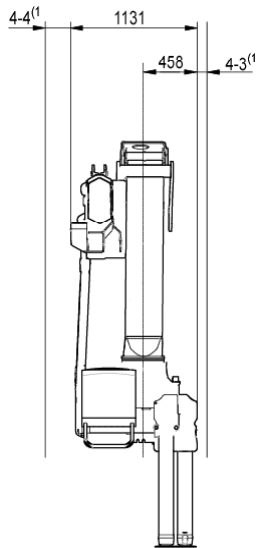

Front View Folded

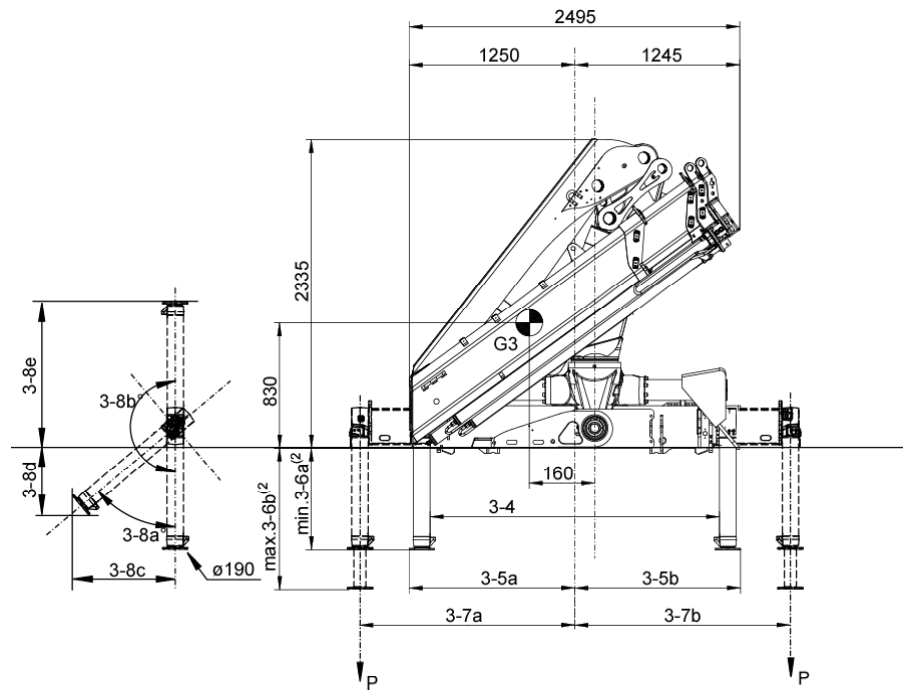

NOTE For specific values, see Table of Measurements

Top View Crane Base

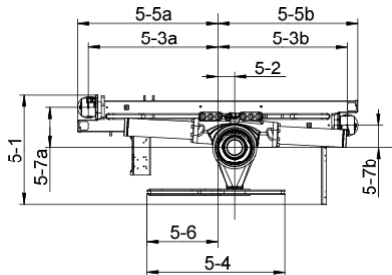

NOTE For specific values, see Table of Measurements

Chassis Installation

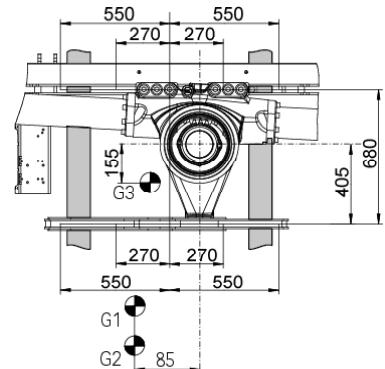

Load Diagram

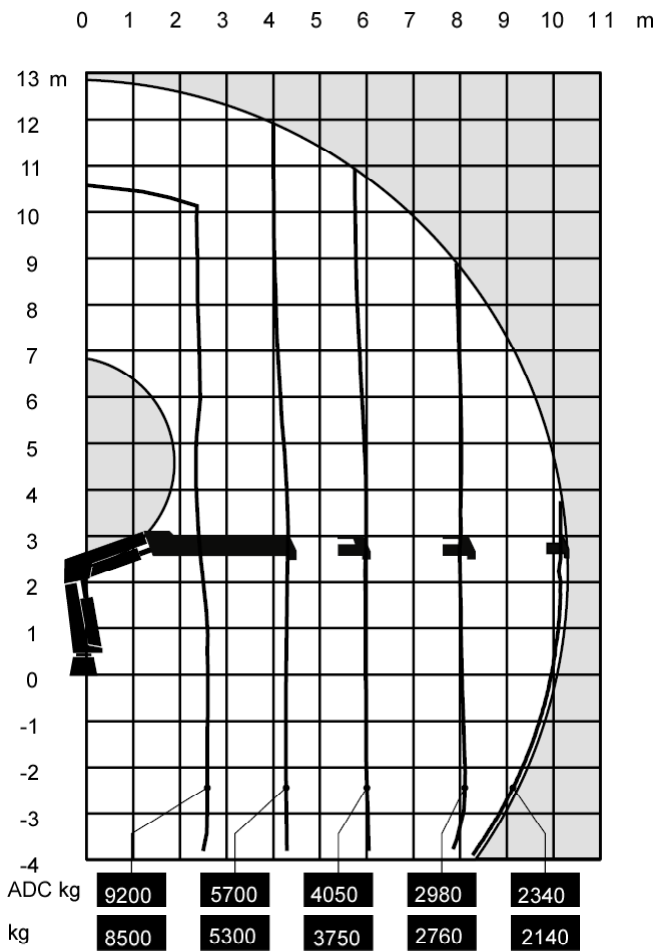

Capacity and performance

Lifting capacity with ADC	241.7 (kNm)
Lifting capacity	223.8 (kNm)
Standard lifting capacity at standard outreach with ADC	2.6 (m) - 9200 (kg) 4.3 (m) - 5700 (kg) 6.0 (m) - 4050 (kg) 8.0 (m) - 2980 (kg) 10.2 (m) - 2340 (kg)
Standard lifting capacity at standard outreach	2.6 (m) - 8500 (kg) 4.3 (m) - 5300 (kg) 6.0 (m) - 3750 (kg) 8.0 (m) - 2760 (kg) 10.2 (m) - 2140 (kg)
Manual lifting capacity at extension	12.5 (m) - 1820 (kg) 14.9 (m) - 1460 (kg)
Heavy lift capacity at heavy lift outreach	2.2 (m) - 10600 (kg)
Hydraulic boom extension	6.0 (m)
Manual max outreach	17.4 (m)
Lifting height above installation level hydraulic	12.9 (m)
Lifting height above installation level manual	17.5 (m)
Slewing torque	34 (kNm)
V80 Slewing speed	15 (°/s)
Slewing angle	420 (°)
Lifting speed	1.2 m/s

Functional demands

Recommended oilflow low	50 (l/min)
Recommended oilflow high	70 (l/min)
Working pressure	31 (MPa)
Max slope viable at full capacity	5 (°)

Weights and measurements

Height in folded position	2335 (mm)
Width in folded position	2495 (mm)
Installation space needed	1131 (mm)
Weight of crane	2830 (kg)
Weight support leg equipment	402 (kg)

Side View Unfolded Close in Area

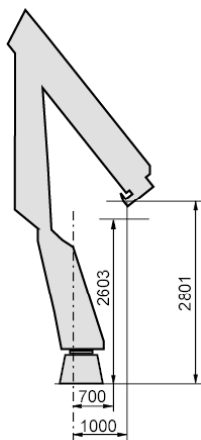

Side View Unfolded Stretched

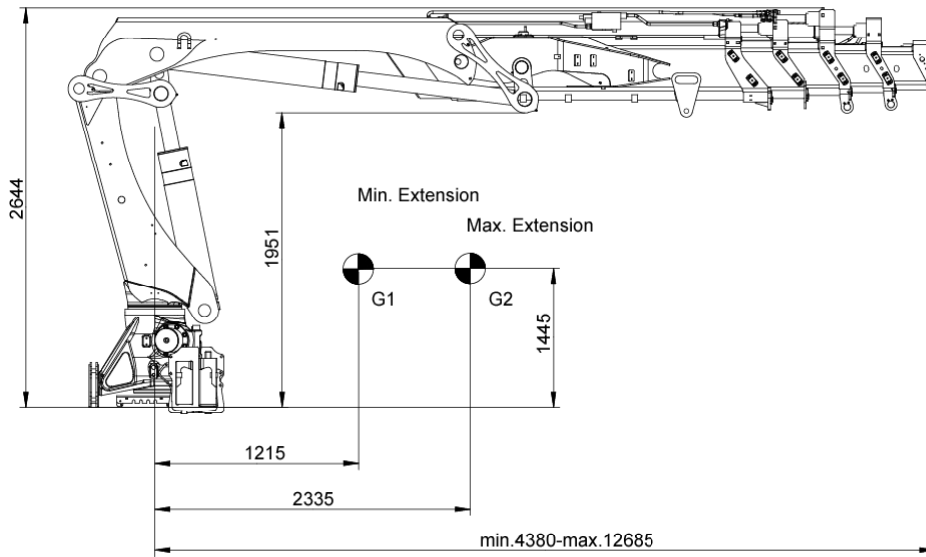

Side View Folded

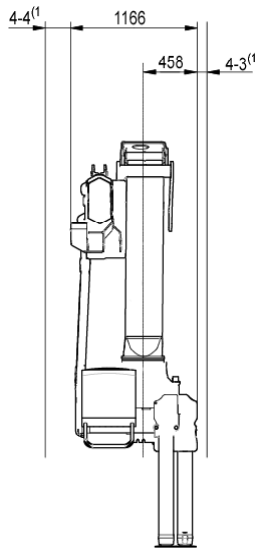

Front View Folded

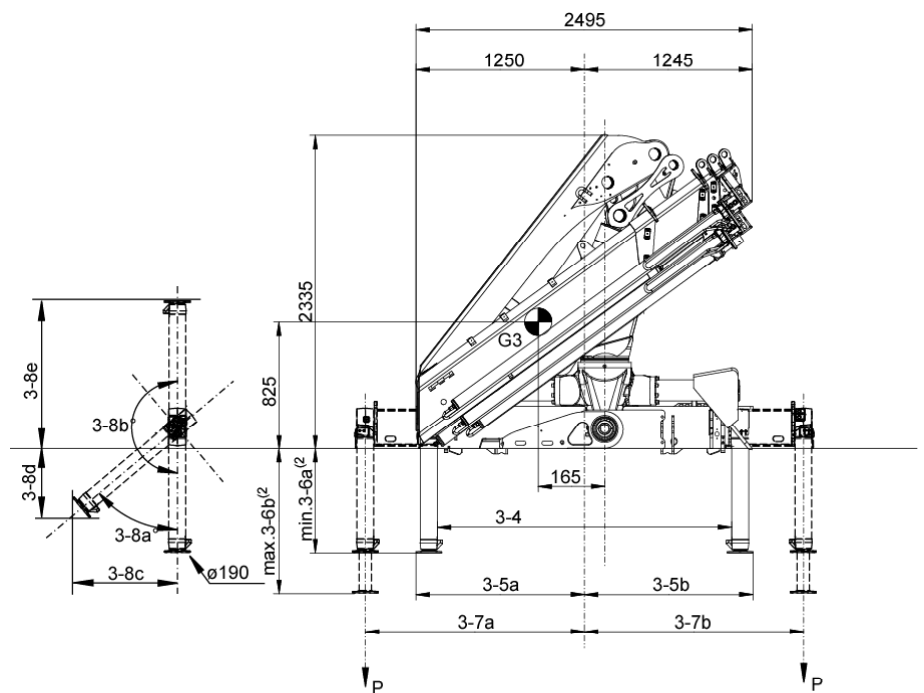

NOTE For specific values, see Table of Measurements

Top View Crane Base

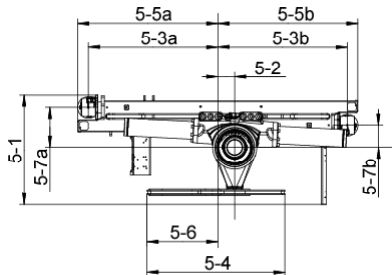

NOTE For specific values, see Table of Measurements

Chassis Installation

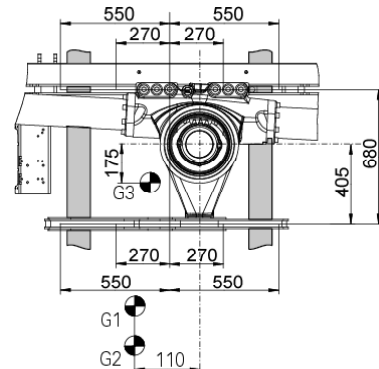

(1) Variable value depending on option.
 (2) Variations may occur depending on mounting position.

Load Diagram

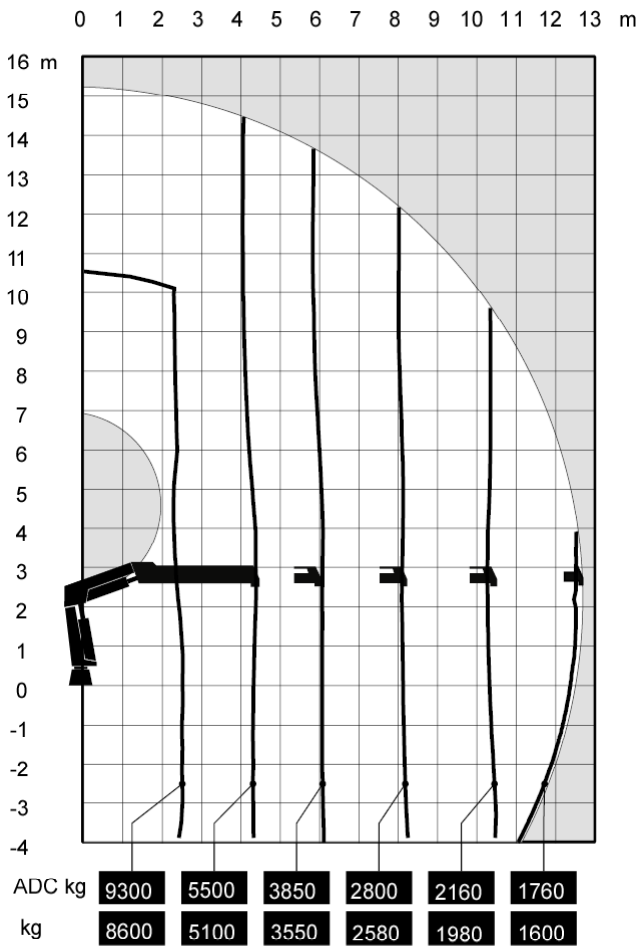

Side View Unfolded Close in Area

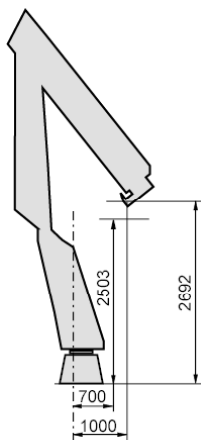

Capacity and performance

Lifting capacity with ADC	236.6 (kNm)
Lifting capacity	218.7 (kNm)
Standard lifting capacity at standard outreach with ADC	2.5 (m) - 9300 (kg)
	4.4 (m) - 5500 (kg)
	6.1 (m) - 3850 (kg)
	8.1 (m) - 2800 (kg)
	10.3 (m) - 2160 (kg)
	12.6 (m) - 1760 (kg)
Standard lifting capacity at standard outreach	2.5 (m) - 8600 (kg)
	4.4 (m) - 5100 (kg)
	6.1 (m) - 3550 (kg)
	8.1 (m) - 2580 (kg)
	10.3 (m) - 1980 (kg)
	12.6 (m) - 1600 (kg)
Manual lifting capacity at extension	15.0 (m) - 1380 (kg)
	17.2 (m) - 1140 (kg)
Heavy lift capacity at heavy lift outreach	2.2 (m) - 10500 (kg)
Hydraulic boom extension	8.3 (m)
Manual max outreach	17.4 (m)
Lifting height above installation level hydraulic	15.3 (m)
Lifting height above installation level manual	19.8 (m)
Slewing torque	34 (kNm)
V80 Slewing speed	15 (°/s)
Slewing angle	420 (°)
Lifting speed	1.5 m/s

Functional demands

Recommended oil flow low	50 (l/min)
Recommended oil flow high	70 (l/min)
Working pressure	31 (MPa)
Max slope viable at full capacity	5 (°)

Weights and measurements

Height in folded position	2335 (mm)
Width in folded position	2495 (mm)
Installation space needed	1166 (mm)
Weight of crane	3000 (kg)
Weight support leg equipment	402 (kg)

Side View Unfolded Stretched

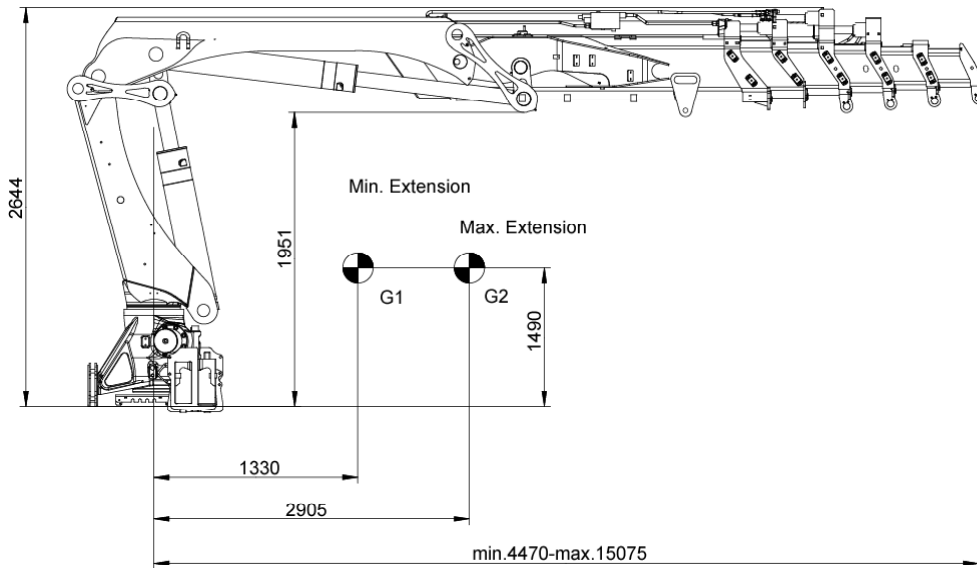

Side View Folded

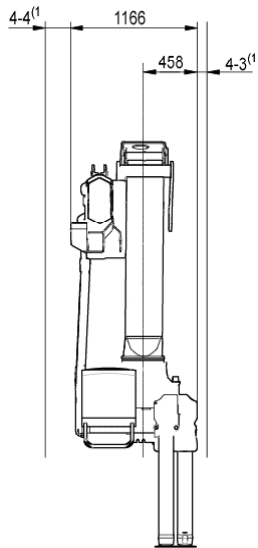

Front View Folded

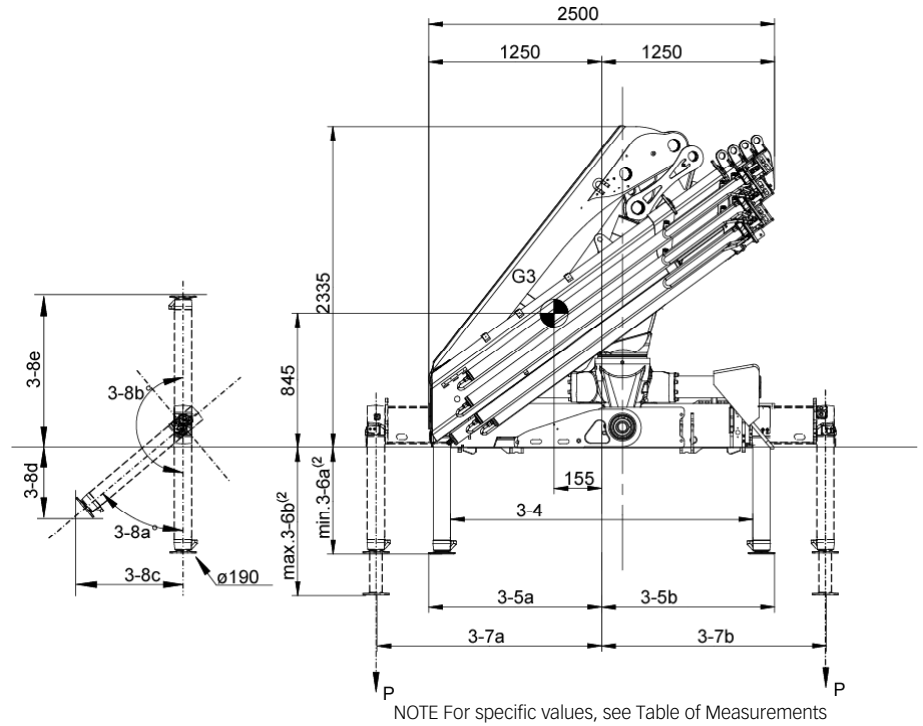

Top View Crane Base

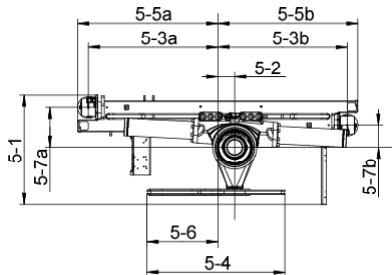

NOTE For specific values, see Table of Measurements

Chassis Installation

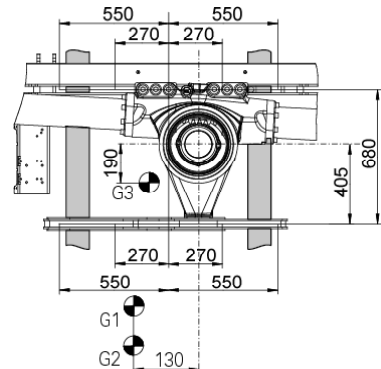

(1) Variable value depending on option.
 (2) Variations may occur depending on mounting position.

Load Diagram

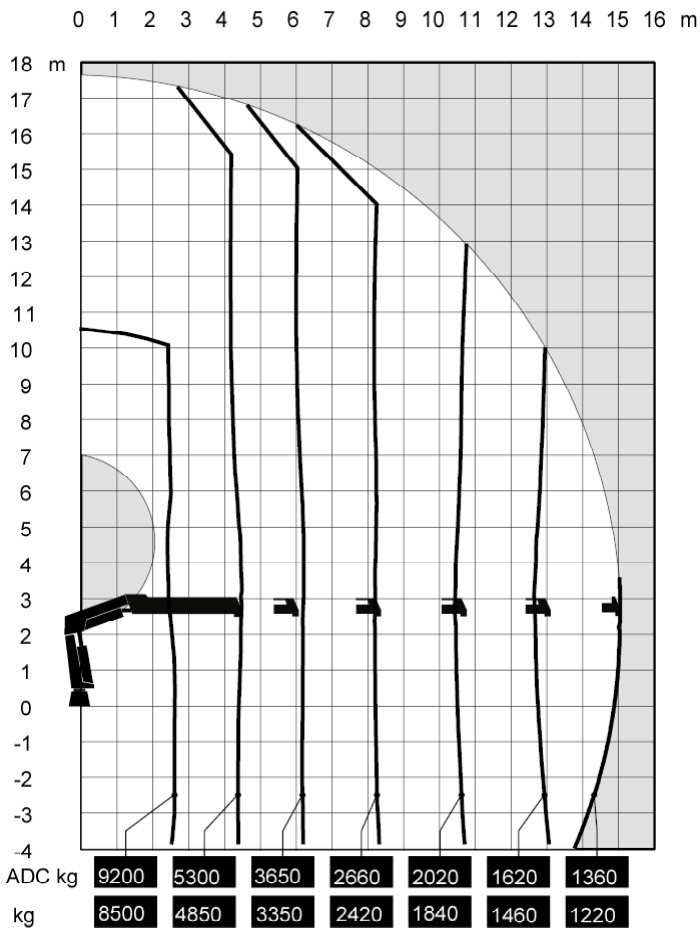

Capacity and performance

Lifting capacity with ADC	232.5 (kNm)
Lifting capacity	214.5 (kNm)
Standard lifting capacity at standard outreach with ADC	2.5 (m) - 9200 (kg)
	4.5 (m) - 5300 (kg)
	6.2 (m) - 3650 (kg)
	8.2 (m) - 2660 (kg)
	10.4 (m) - 2020 (kg)
	12.7 (m) - 1620 (kg)
	15.0 (m) - 1360 (kg)
Standard lifting capacity at standard outreach	2.5 (m) - 8500 (kg)
	4.5 (m) - 4850 (kg)
	6.2 (m) - 3350 (kg)
	8.2 (m) - 2420 (kg)
	10.4 (m) - 1840 (kg)
	12.7 (m) - 1460 (kg)
	15.0 (m) - 1220 (kg)
Manual lifting capacity at extension	17.2 (m) - 1120 (kg)
Heavy lift capacity at heavy lift outreach	2.2 (m) - 10300 (kg)
Hydraulic boom extension	10.6 (m)
Manual max outreach	17.4 (m)
Lifting height above installation level hydraulic	17.7 (m)
Lifting height above installation level manual	19.8 (m)
Slewing torque	34 (kNm)
V80 Slewing speed	15 (°/s)
Slewing angle	420 (°)
Lifting speed	1.8 (m/s)

Functional demands

Recommended oil flow low	50 (l/min)
Recommended oil flow high	70 (l/min)
Working pressure	31 (MPa)
Max slope viable at full capacity	5 (°)

Weights and measurements

Height in folded position	2335 (mm)
Width in folded position	2500 (mm)
Installation space needed	1166 (mm)
Weight of crane	3140 (kg)
Weight support leg equipment	402 (kg)

Side View Unfolded Close in Area

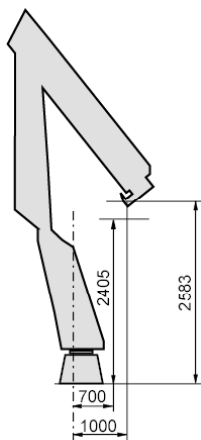

Side View Unfolded Stretched

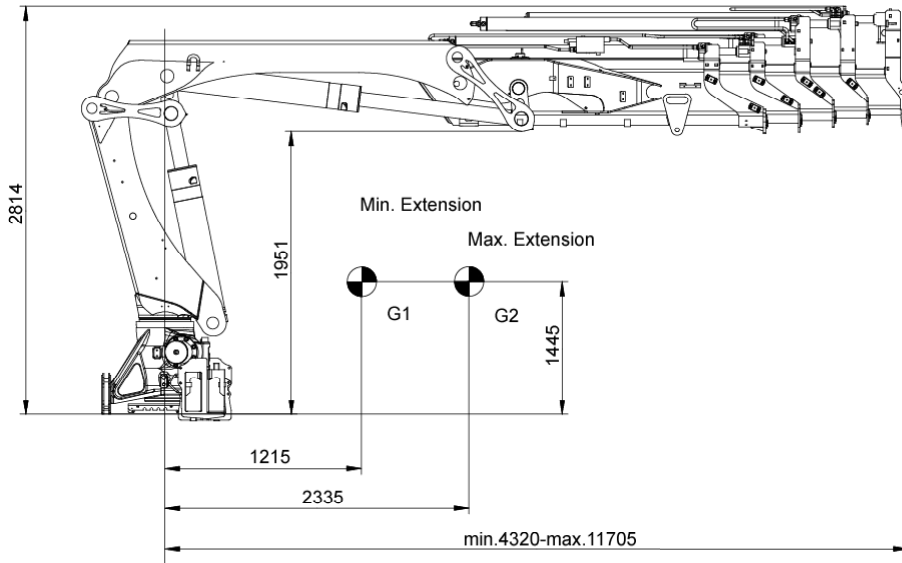

Side View Folded

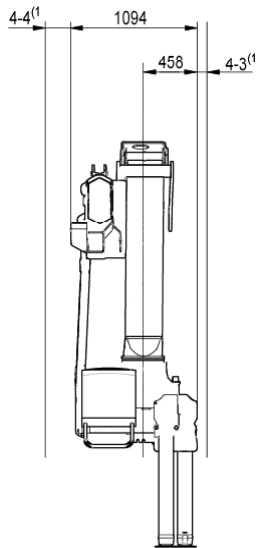

Front View Folded

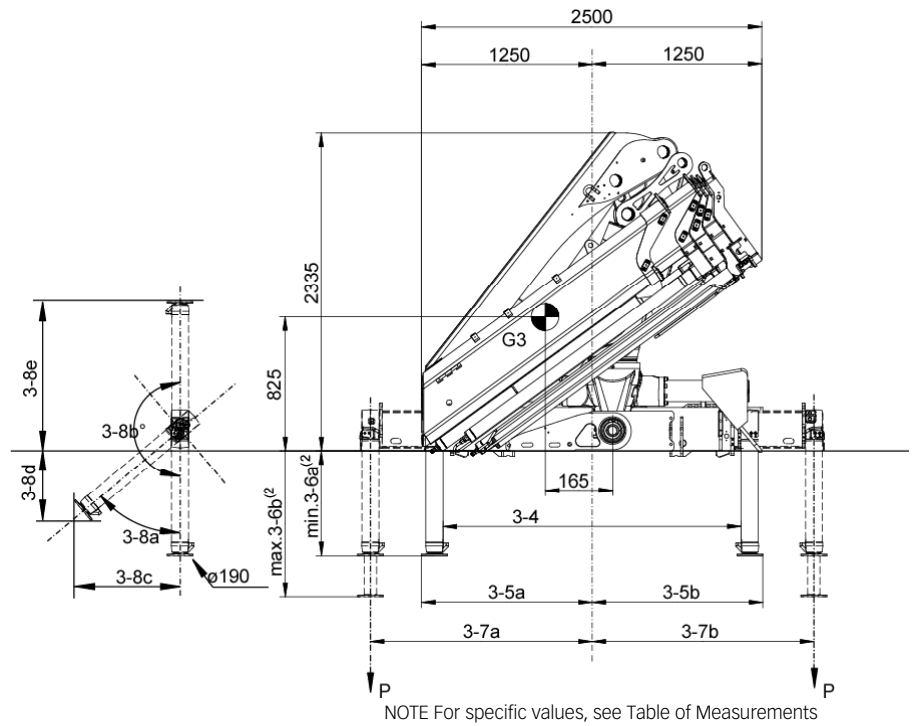

Top View Crane Base

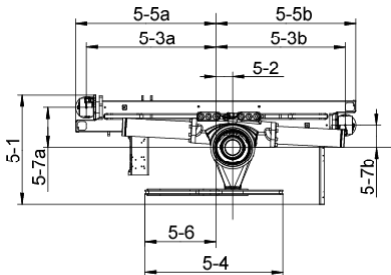

NOTE For specific values, see Table of Measurements

Chassis Installation

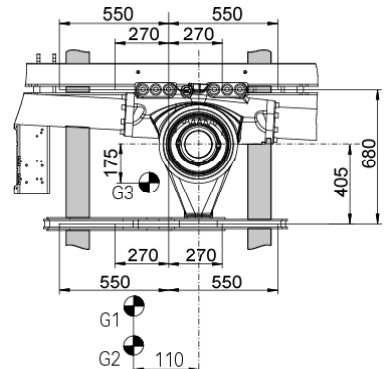

(1) Variable value depending on option.
 (2) Variations may occur depending on mounting position.

Load Diagram

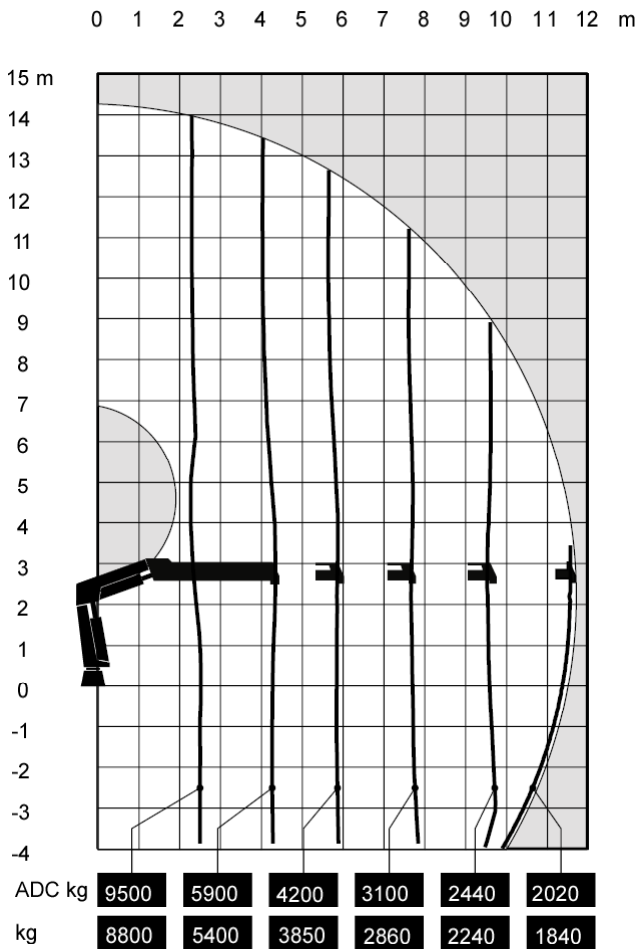

Side View Unfolded Close in Area

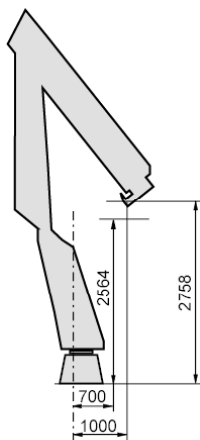

Capacity and performance

Lifting capacity with ADC	248.3 (kNm)
Lifting capacity	229.4 (kNm)
Standard lifting capacity at standard outreach with ADC	2.6 (m) - 9500 (kg)
	4.3 (m) - 5900 (kg)
	5.9 (m) - 4200 (kg)
	7.7 (m) - 3100 (kg)
	9.6 (m) - 2440 (kg)
	11.6 (m) - 2020 (kg)
Standard lifting capacity at standard outreach	2.6 (m) - 8800 (kg)
	4.3 (m) - 5400 (kg)
	5.9 (m) - 3850 (kg)
	7.7 (m) - 2860 (kg)
	9.6 (m) - 2240 (kg)
	11.6 (m) - 1840 (kg)
Manual lifting capacity at extension	13.7 (m) - 1620 (kg)
	15.9 (m) - 1340 (kg)
Heavy lift capacity at heavy lift outreach	2.2 (m) - 11000 (kg)
Hydraulic boom extension	7.4 (m)
Manual max outreach	18.6 (m)
Lifting height above installation level hydraulic	14.3 (m)
Lifting height above installation level manual	18.5 (m)
Slewing torque	34 (kNm)
V80 Slewing speed	15 (°/s)
Slewing angle	420 (°)
Lifting speed	1.8 m/s

Functional demands

Recommended oil flow low	70 (l/min)
Recommended oil flow high	90 (l/min)
Working pressure	33 (MPa)
Max slope viable at full capacity	5 (°)

Weights and measurements

Height in folded position	2335 (mm)
Width in folded position	2500 (mm)
Installation space needed	1094 (mm)
Weight of crane	3070 (kg)
Weight support leg equipment	402 (kg)

Side View Unfolded Stretched

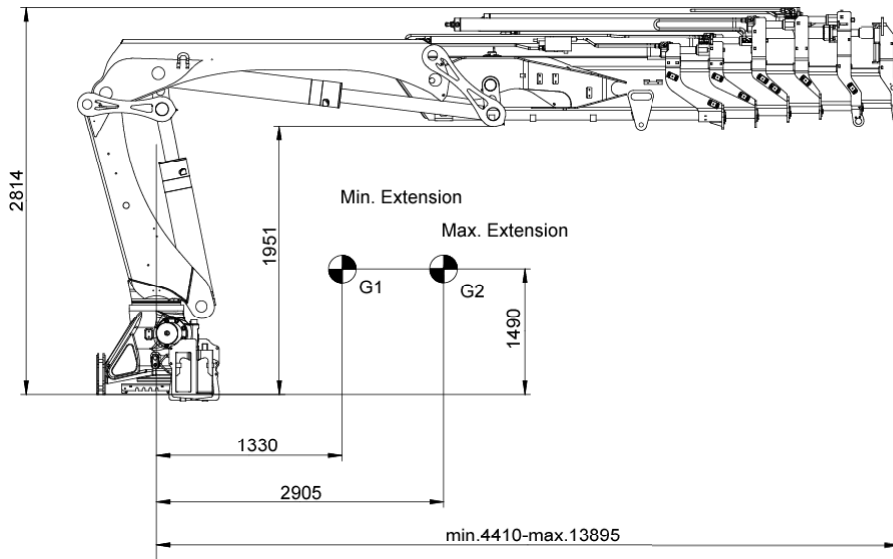

Side View Folded

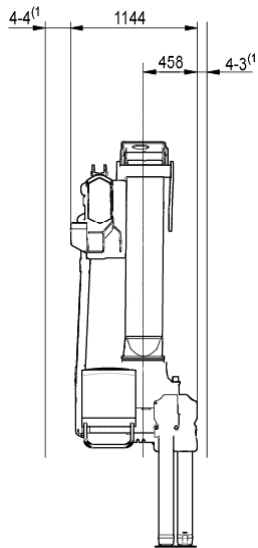

Front View Folded

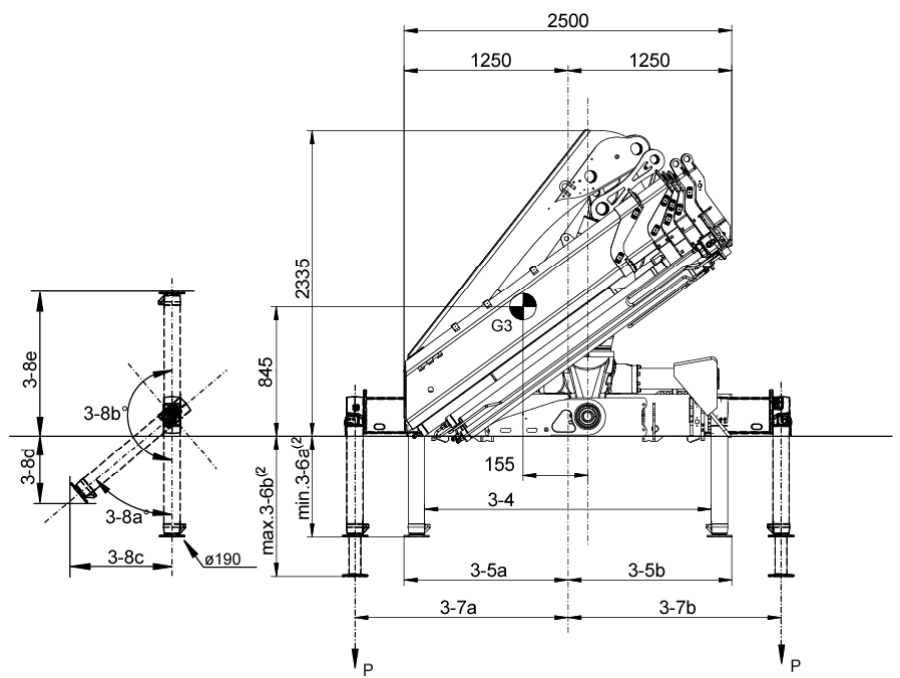

NOTE For specific values, see Table of Measurements

Top View Crane Base

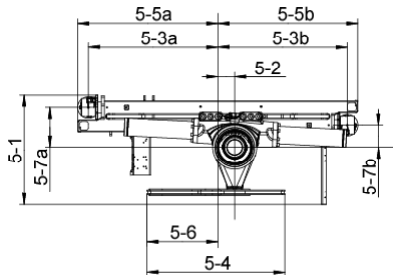

NOTE For specific values, see Table of Measurements

Chassis Installation

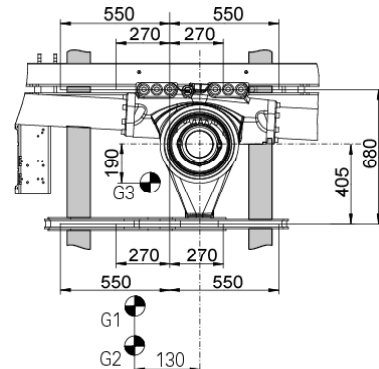

(1) Variable value depending on option.
 (2) Variations may occur depending on mounting position.

Load Diagram

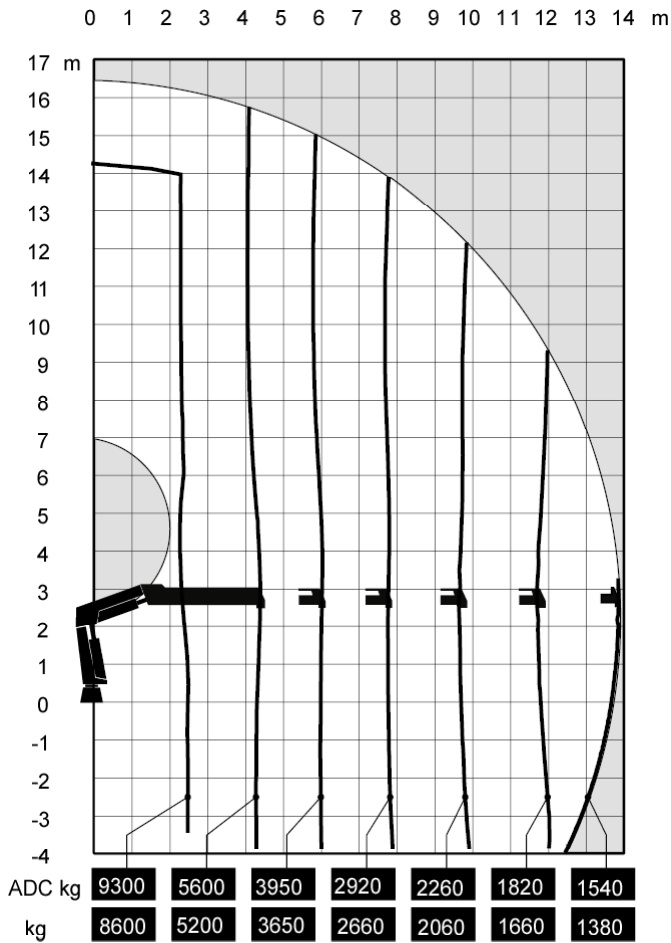

Capacity and performance

Lifting capacity with ADC	242.6 (kNm)
Lifting capacity	223.7 (kNm)
Standard lifting capacity at standard outreach with ADC	2.6 (m) - 9300 (kg) 4.4 (m) - 5600 (kg) 6.0 (m) - 3950 (kg) 7.8 (m) - 2920 (kg) 9.7 (m) - 2260 (kg) 11.7 (m) - 1820 (kg) 13.8 (m) - 1540 (kg)
Standard lifting capacity at standard outreach	2.6 (m) - 8600 (kg) 4.4 (m) - 5200 (kg) 6.0 (m) - 3650 (kg) 7.8 (m) - 2660 (kg) 9.7 (m) - 2060 (kg) 11.7 (m) - 1660 (kg) 13.8 (m) - 1380 (kg)
Manual lifting capacity at extension	15.8 (m) - 1280 (kg) 17.5 (m) - 1080 (kg)
Heavy lift capacity at heavy lift outreach	2.2 (m) - 10800 (kg)
Hydraulic boom extension	9.5 (m)
Manual max outreach	21.0 (m)
Lifting height above installation level hydraulic	16.5 (m)
Lifting height above installation level manual	20.1 (m)
Slewing torque	34 (kNm)
V80 Slewing speed	15 (°/s)
Slewing angle	420 (°)
Lifting speed	2.1 m/s

Functional demands

Recommended oil flow low	70 (l/min)
Recommended oil flow high	90 (l/min)
Working pressure	33 (MPa)
Max slope viable at full capacity	5 (°)

Weights and measurements

Height in folded position	2335 (mm)
Width in folded position	2500 (mm)
Installation space needed	1144 (mm)
Weight of crane	3250 (kg)
Weight support leg equipment	402 (kg)

Side View Unfolded Close in Area

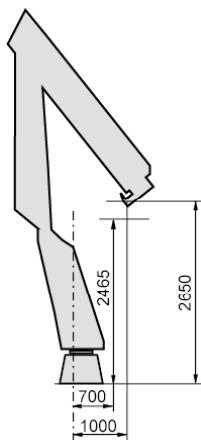

Side View Unfolded Stretched

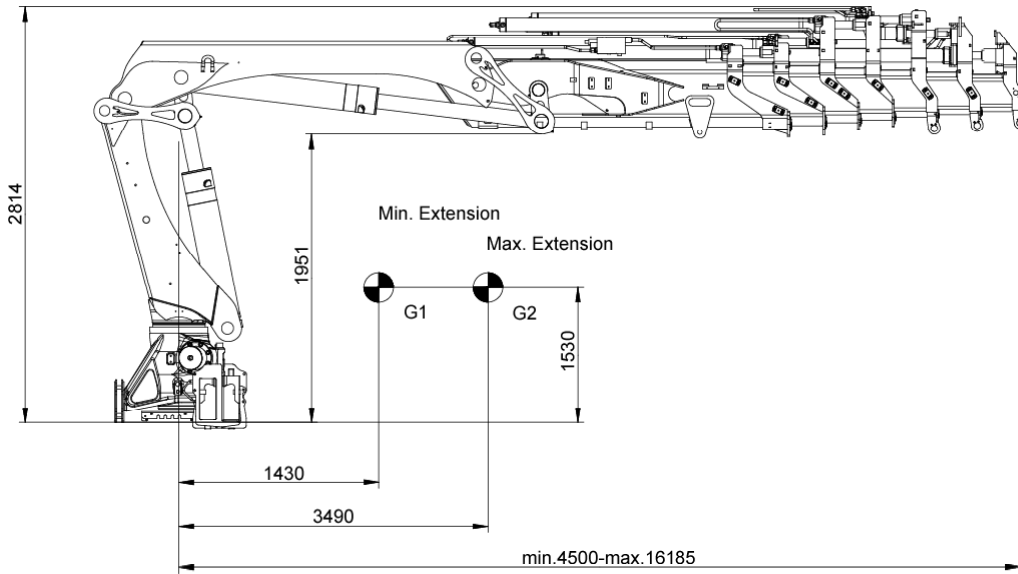

Side View Folded

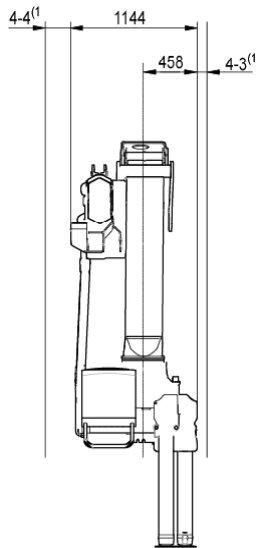

Front View Folded

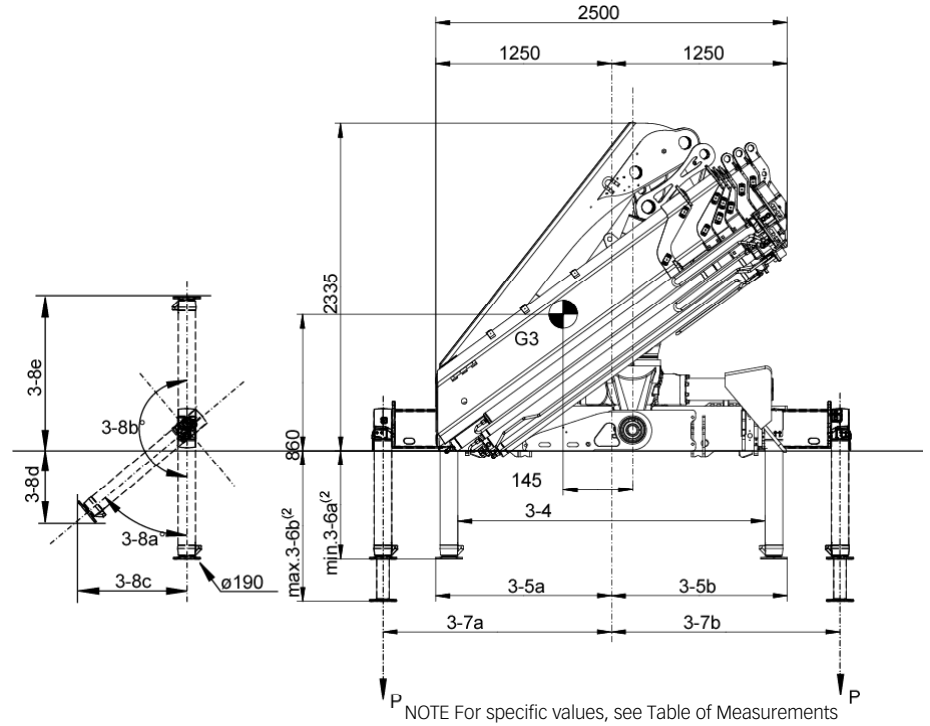

Top View Crane Base

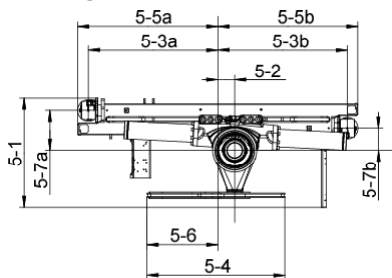

NOTE For specific values, see Table of Measurements

Chassis Installation

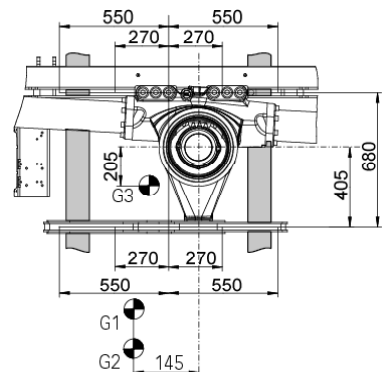

(1) Variable value depending on option.
 (2) Variations may occur depending on mounting position.

Load Diagram

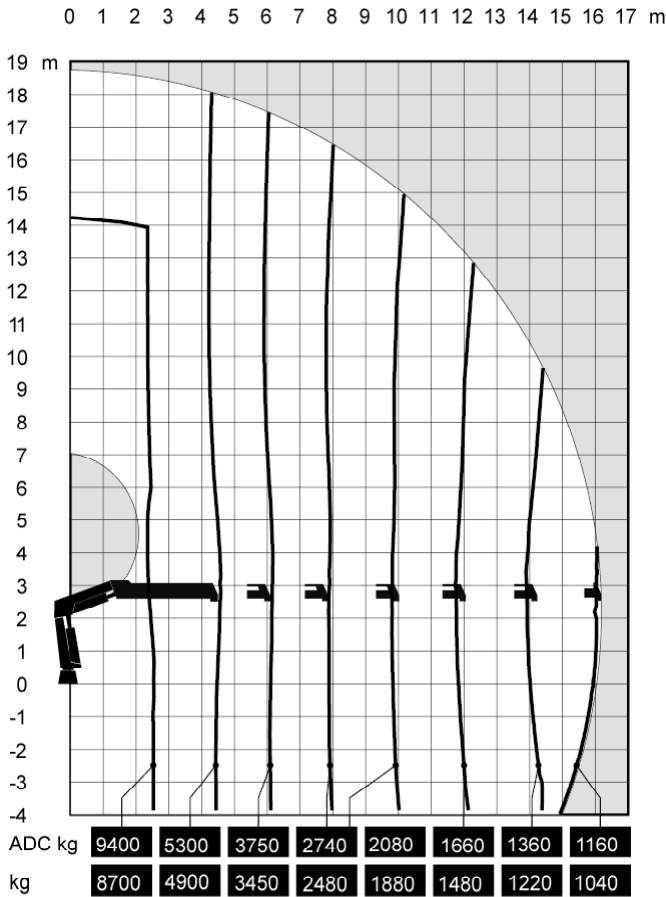

Capacity and performance

Lifting capacity with ADC	237.1 (kNm)
Lifting capacity	218.2 (kNm)
Standard lifting capacity at standard outreach with ADC	2.5 (m) - 9400 (kg) 4.5 (m) - 5300 (kg) 6.1 (m) - 3750 (kg) 7.9 (m) - 2740 (kg) 9.8 (m) - 2080 (kg) 11.8 (m) - 1660 (kg) 13.9 (m) - 1360 (kg) 16.1 (m) - 1160 (kg)
Standard lifting capacity at standard outreach	2.5 (m) - 8700 (kg) 4.5 (m) - 4900 (kg) 6.1 (m) - 3450 (kg) 7.9 (m) - 2480 (kg) 9.8 (m) - 1880 (kg) 11.8 (m) - 1480 (kg) 13.9 (m) - 1220 (kg) 16.1 (m) - 1040 (kg)
Manual lifting capacity at extension	18.3 (m) - 940 (kg) 20.4 (m) - 800 (kg)
Heavy lift capacity at heavy lift outreach	2.2 (m) - 10600 (kg)
Hydraulic boom extension	11.7 (m)
Manual max outreach	23.3 (m)
Lifting height above installation level hydraulic	18.8 (m)
Lifting height above installation level manual	23.1 (m)
Slewing torque	34 (kNm)
V80 Slewing speed	15 (°/s)
Slewing angle	420 (°)
Lifting speed	2.5 m/s

Side View Unfolded Close in Area

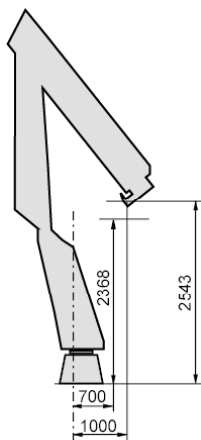

Functional demands

Recommended oil flow low	70 (l/min)
Recommended oil flow high	90 (l/min)
Working pressure	33 (MPa)
Max slope viable at full capacity	5 (°)

Weights and measurements

Height in folded position	2335 (mm)
Width in folded position	2500 (mm)
Installation space needed	1144 (mm)
Weight of crane	3420 (kg)
Weight support leg equipment	402 (kg)

Side View Unfolded Stretched

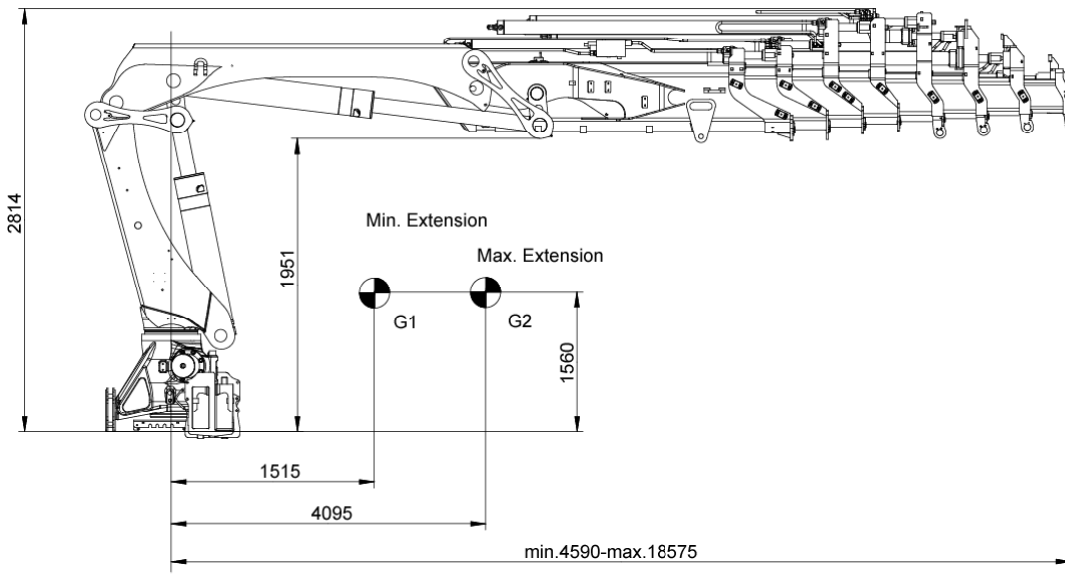

Side View Folded

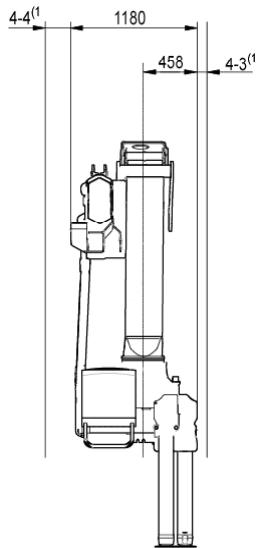

Front View Folded

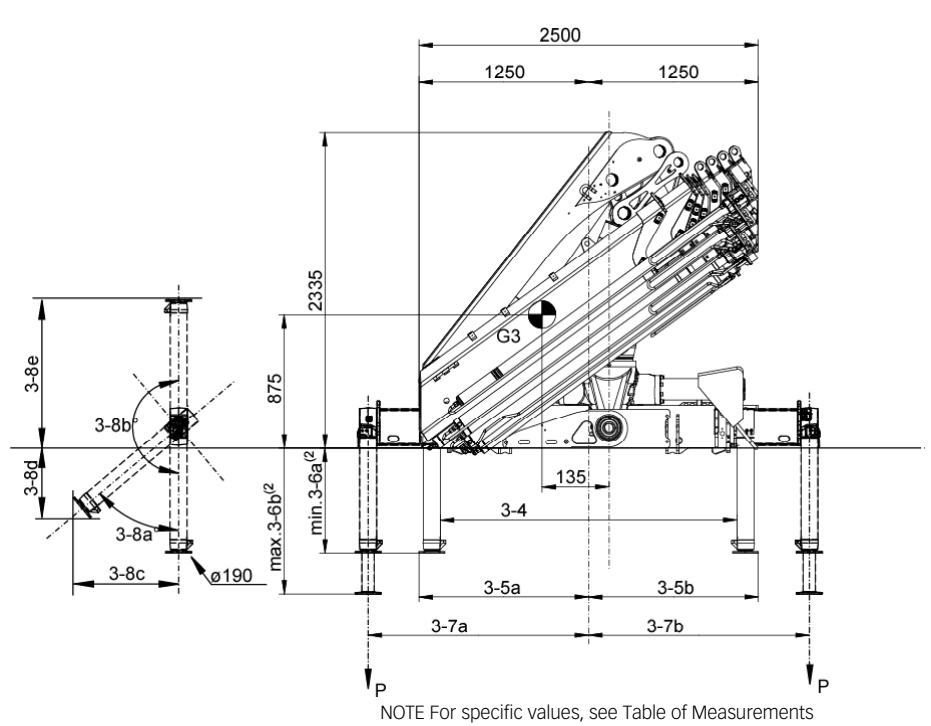

Top View Crane Base

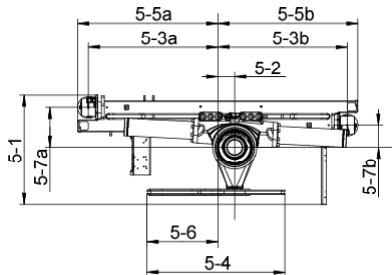

NOTE For specific values, see Table of Measurements

Chassis Installation

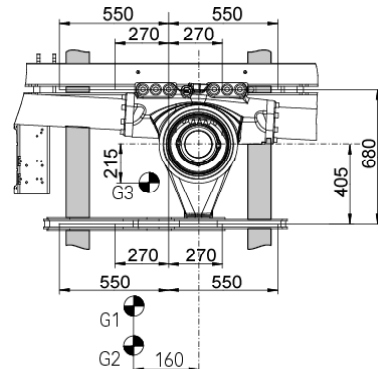

(1) Variable value depending on option.
 (2) Variations may occur depending on mounting position.

Load Diagram

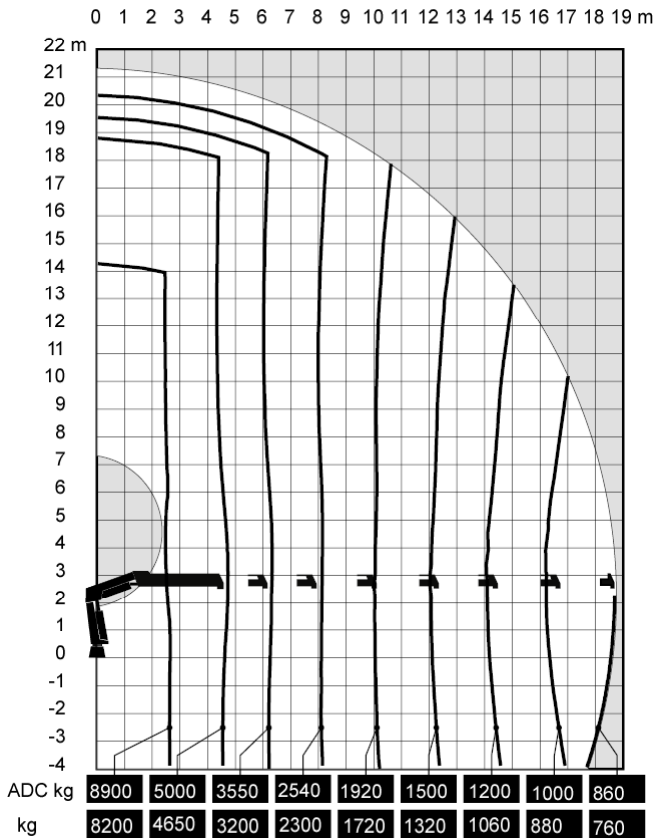

Side View Unfolded Close in Area

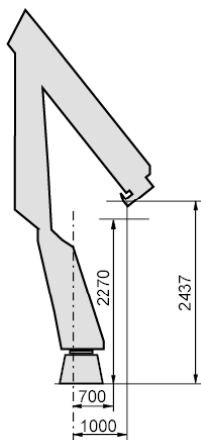

Capacity and performance

Lifting capacity with ADC	233.3 (kNm)
Lifting capacity	214.3 (kNm)
Standard lifting capacity at standard outreach with ADC	2.6 (m) - 8900 (kg)
	4.7 (m) - 5000 (kg)
	6.3 (m) - 3550 (kg)
	8.1 (m) - 2540 (kg)
	10.0 (m) - 1920 (kg)
	12.0 (m) - 1500 (kg)
	14.1 (m) - 1200 (kg)
	16.3 (m) - 1000 (kg)
	18.6 (m) - 860 (kg)
Standard lifting capacity at standard outreach	2.6 (m) - 8200 (kg)
	4.7 (m) - 4650 (kg)
	6.3 (m) - 3200 (kg)
	8.1 (m) - 2300 (kg)
	10.0 (m) - 1720 (kg)
	12.0 (m) - 1320 (kg)
	14.1 (m) - 1060 (kg)
	16.3 (m) - 880 (kg)
	18.6 (m) - 760 (kg)
Manual lifting capacity at extension	20.1 (m) - 720 (kg)
	21.6 (m) - 620 (kg)
Heavy lift capacity at heavy lift outreach	2.2 (m) - 10400 (kg)
Hydraulic boom extension	14.0 (m)
Manual max outreach	23.2 (m)
Lifting height above installation level hydraulic	21.2 (m)
Lifting height above installation level manual	24.2 (m)
Slewing torque	34 (kNm)
V80 Slewing speed	15 (°/s)
Slewing angle	420 (°)
Lifting speed	2.9 (m/s)

Functional demands

Recommended oil flow low	70 (l/min)
Recommended oil flow high	90 (l/min)
Working pressure	33 (MPa)
Max slope viable at full capacity	5 (°)

Weights and measurements

Height in folded position	2335 (mm)
Width in folded position	2500 (mm)
Installation space needed	1180 (mm)
Weight of crane	3580 (kg)
Weight support leg equipment	402 (kg)

Side View Unfolded Stretched

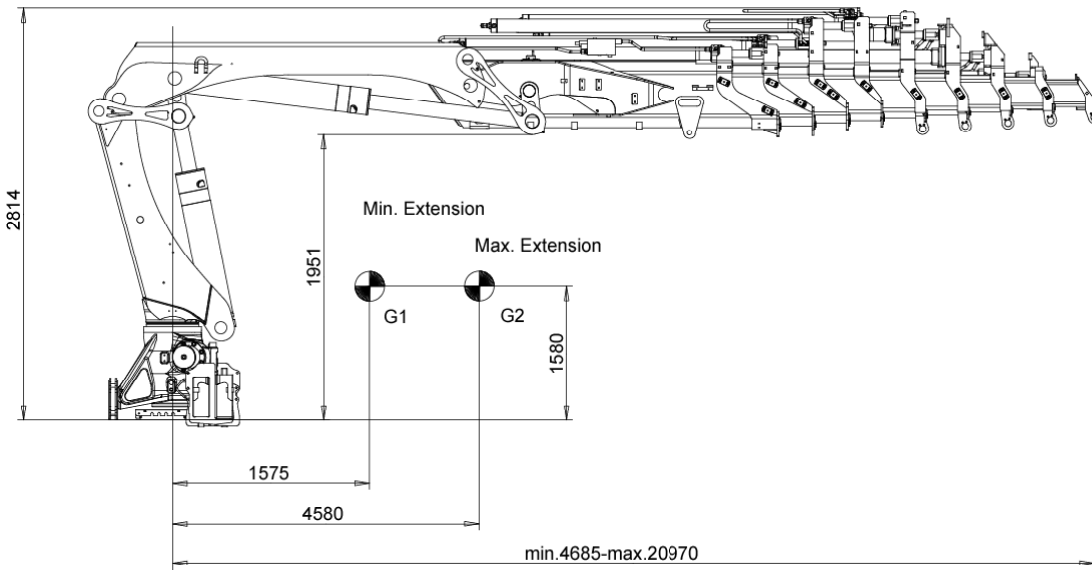

Side View Folded

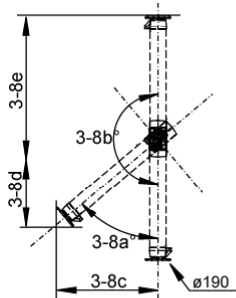
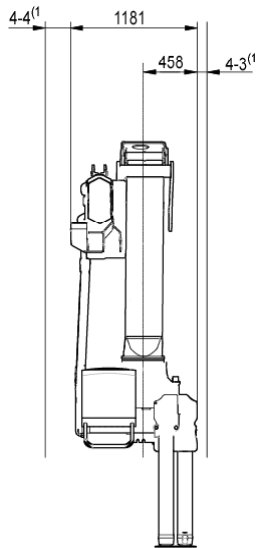

Front View Folded

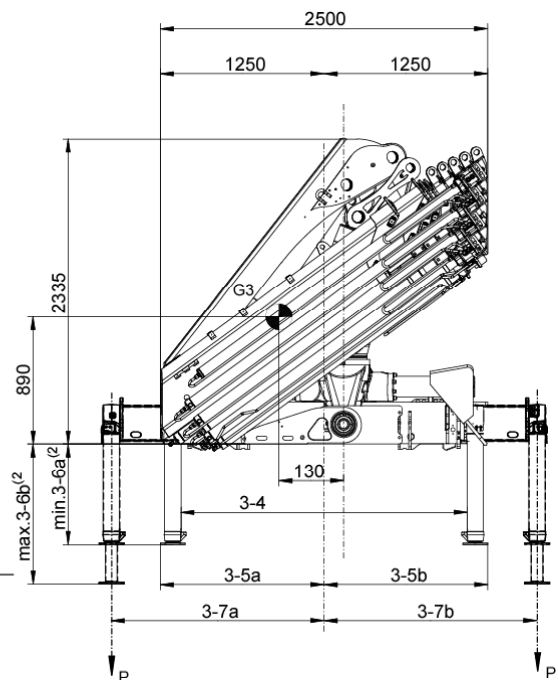

NOTE For specific values, see Table of Measurements

Top View Crane Base

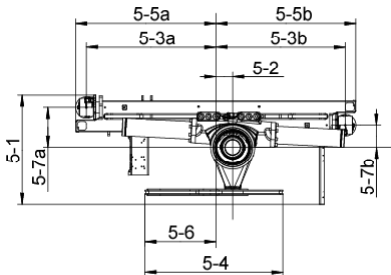

NOTE For specific values, see Table of Measurements

Chassis Installation

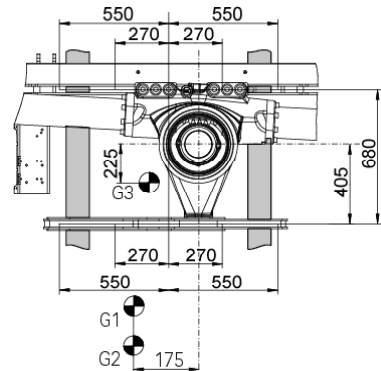

Load Diagram

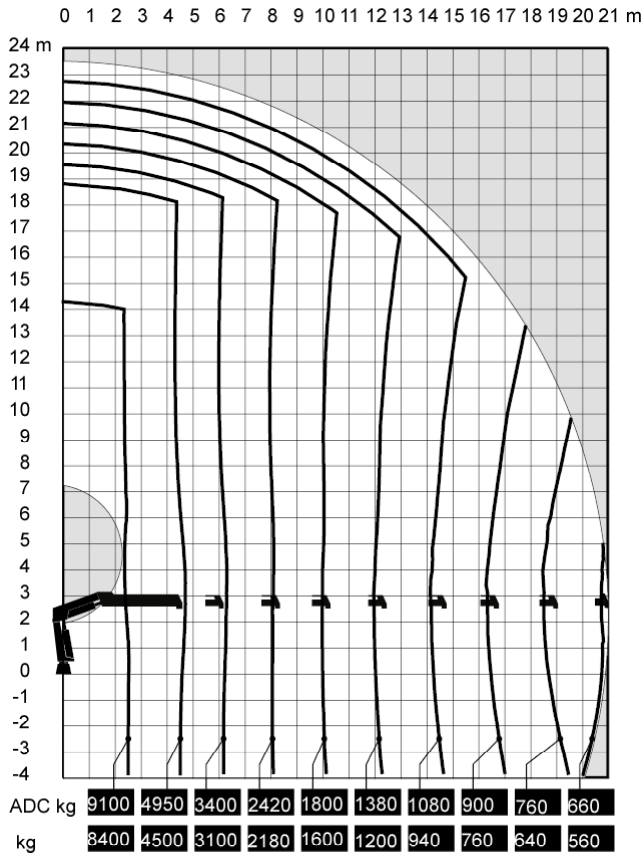

Capacity and performance

Lifting capacity with ADC	228.1 (kNm)
Lifting capacity	209.1 (kNm)
Standard lifting capacity at standard outreach with ADC	2.5 (m) - 9100 (kg) 4.7 (m) - 4950 (kg) 6.3 (m) - 3400 (kg) 8.1 (m) - 2420 (kg) 10.0 (m) - 1800 (kg) 12.0 (m) - 1380 (kg) 14.1 (m) - 1080 (kg) 16.3 (m) - 900 (kg) 18.6 (m) - 760 (kg) 20.9 (m) - 660 (kg)
Standard lifting capacity at standard outreach	2.5 (m) - 8400 (kg) 4.7 (m) - 4500 (kg) 6.3 (m) - 3100 (kg) 8.1 (m) - 2180 (kg) 10.0 (m) - 1600 (kg) 12.0 (m) - 1200 (kg) 14.1 (m) - 940 (kg) 16.3 (m) - 760 (kg) 18.6 (m) - 640 (kg) 20.9 (m) - 560 (kg)
Manual lifting capacity at extension	22.4 (m) - 560 (kg)
Heavy lift capacity at heavy lift outreach	2.2 (m) - 10300 (kg)
Hydraulic boom extension	16.3 (m)
Manual max outreach	23.3 (m)
Lifting height above installation level hydraulic	23.6 (m)
Lifting height above installation level manual	25.1 (m)
Slewing torque	34 (kNm)
V80 Slewing speed	15 (°/s)
Slewing angle	420 (°)
Lifting speed	3.2 m/s

Side View Unfolded Close in Area

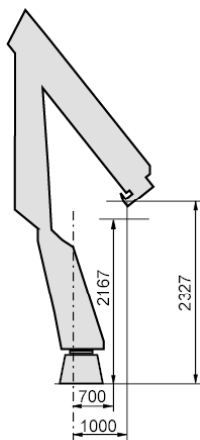

Functional demands

Recommended oil flow low	70 (l/min)
Recommended oil flow high	90 (l/min)
Working pressure	33 (MPa)
Max slope viable at full capacity	5 (°)

Weights and measurements

Height in folded position	2335 (mm)
Width in folded position	2500 (mm)
Installation space needed	1181 (mm)
Weight of crane	3700 (kg)
Weight support leg equipment	402 (kg)

Side View Unfolded Stretched

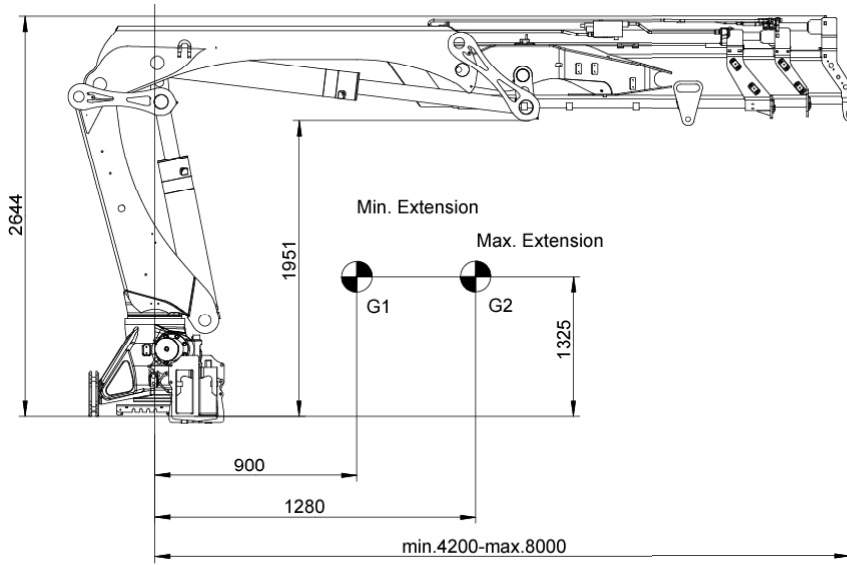

Side View Folded

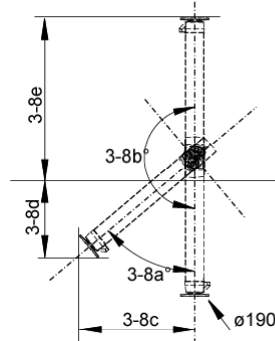
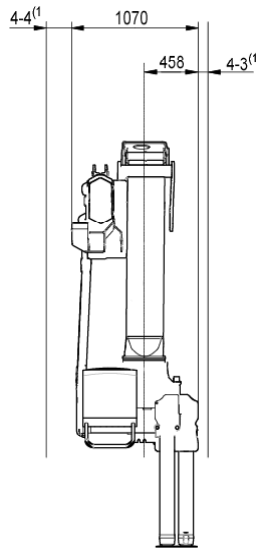

Front View Folded

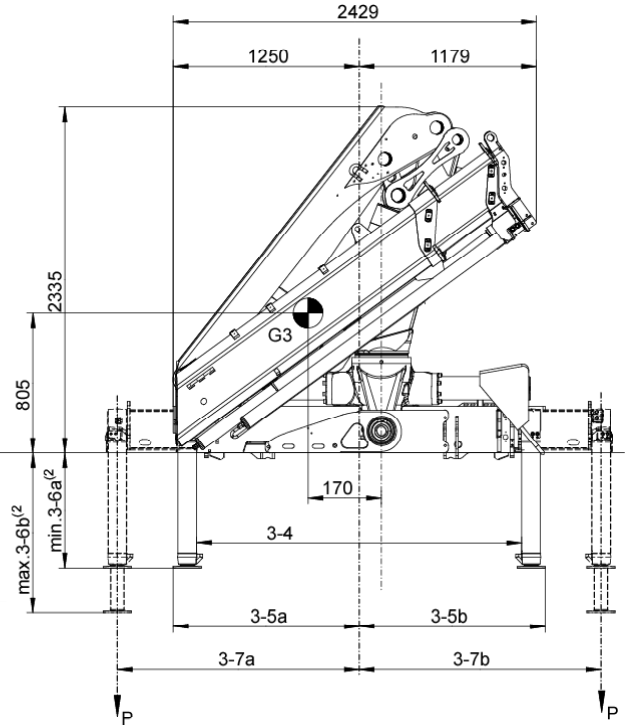

NOTE For specific values, see Table of Measurements

Top View Crane Base

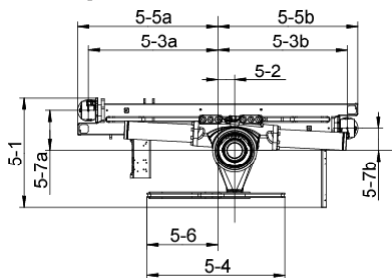

NOTE For specific values, see Table of Measurements

Chassis Installation

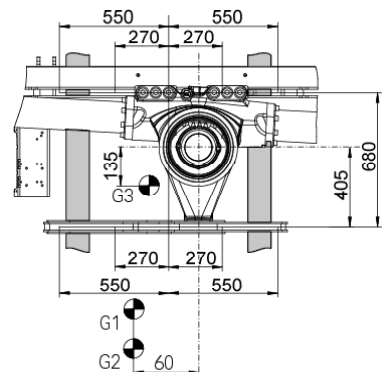

(1) Variable value depending on option.
 (2) Variations may occur depending on mounting position.

Load Diagram

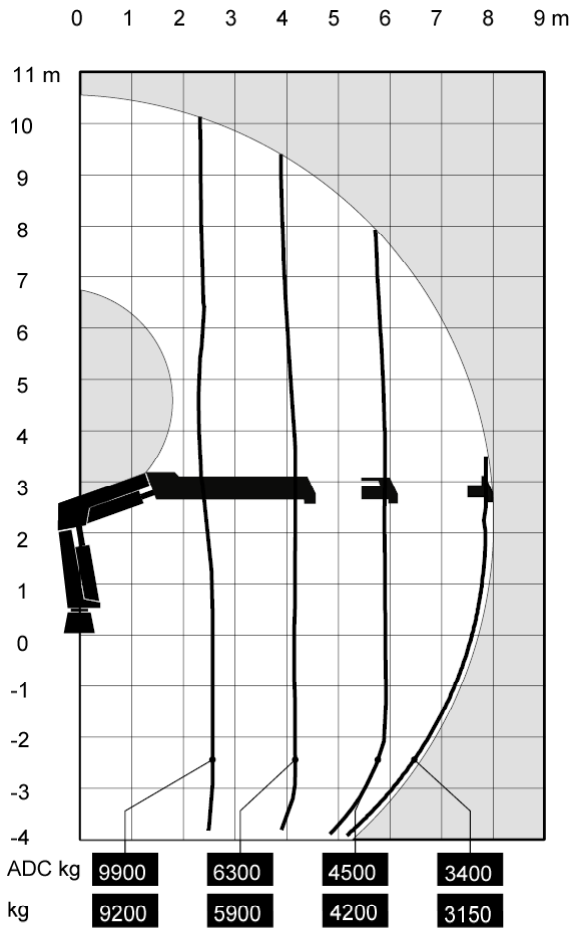

Capacity and performance

Lifting capacity with ADC	262 (kNm)
Lifting capacity	242.5 (kNm)
Standard lifting capacity at standard outreach with ADC	2.6 (m) - 9900 (kg)
	4.2 (m) - 6300 (kg)
	5.9 (m) - 4500 (kg)
	7.9 (m) - 3400 (kg)
Standard lifting capacity at standard outreach	2.6 (m) - 9200 (kg)
	4.2 (m) - 5900 (kg)
	5.9 (m) - 4200 (kg)
	7.9 (m) - 3150 (kg)
Manual lifting capacity at extension	10.1 (m) - 2580 (kg)
	12.5 (m) - 2020 (kg)
Heavy lift capacity at heavy lift outreach	2.2 (m) - 11400 (kg)
Hydraulic boom extension	3.8 (m)
Manual max outreach	15.1 (m)
Lifting height above installation level hydraulic	10.6 (m)
Lifting height above installation level manual	15.1 (m)
Slewing torque	34 (kNm)
V80 Slewing speed	15 (°/s)
Slewing angle	420 (°)
Lifting speed	1.3 m/s

Functional demands

Recommended oil flow low	70 (l/min)
Recommended oil flow high	90 (l/min)
Working pressure	33 (MPa)
Max slope viable at full capacity	5 (°)

Weights and measurements

Height in folded position	2335 (mm)
Width in folded position	2429 (mm)
Installation space needed	1070 (mm)
Weight of crane	2640 (kg)
Weight support leg equipment	402 (kg)

Side View Unfolded Close in Area

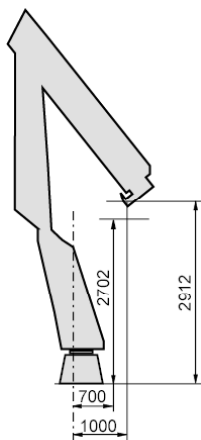

Side View Unfolded Stretched

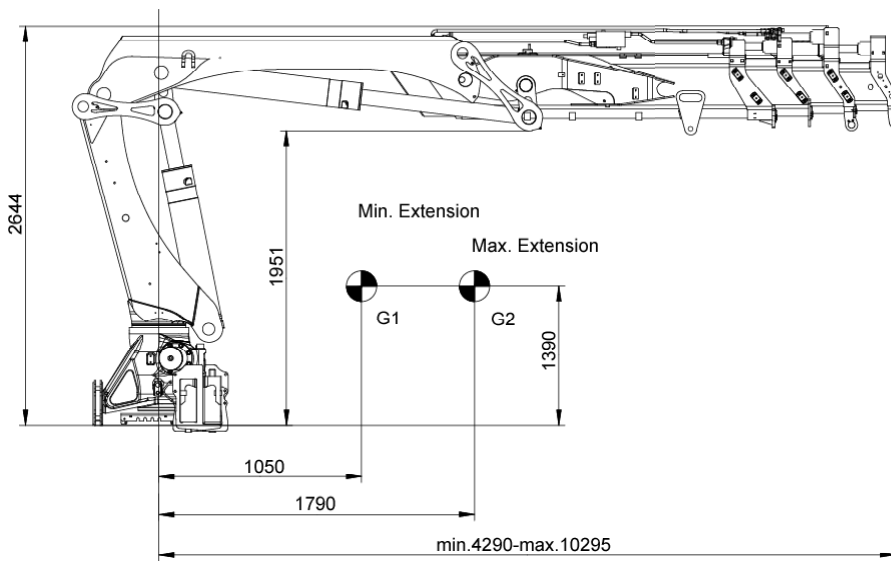

Side View Folded

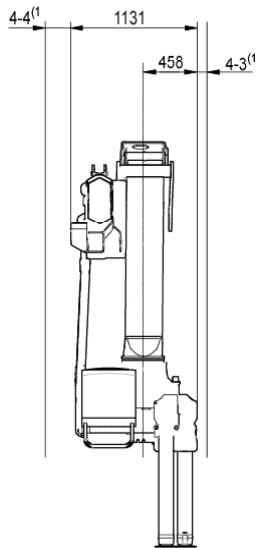

Front View Folded

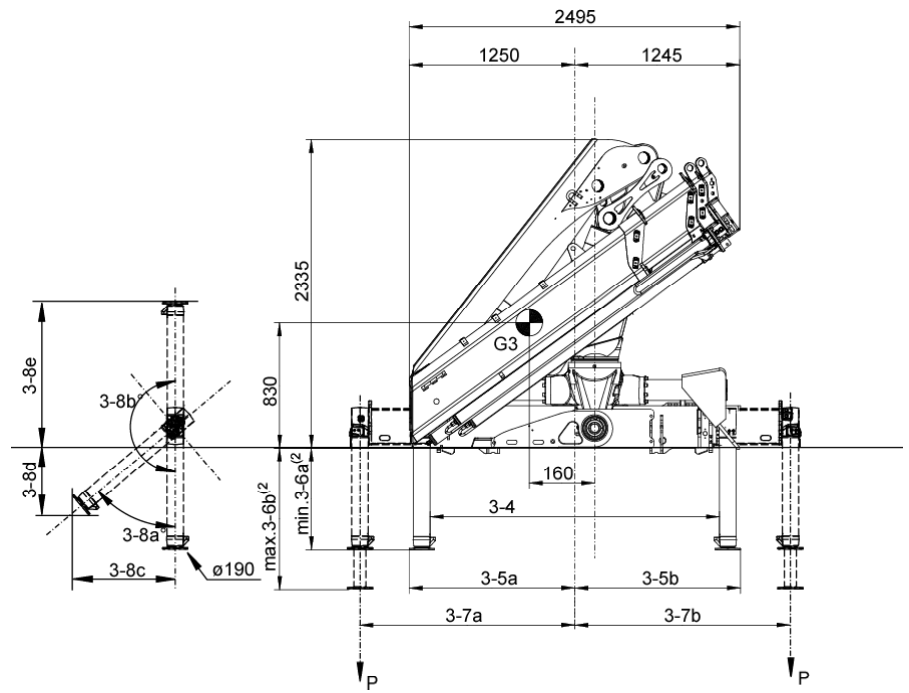

NOTE For specific values, see Table of Measurements

Top View Crane Base

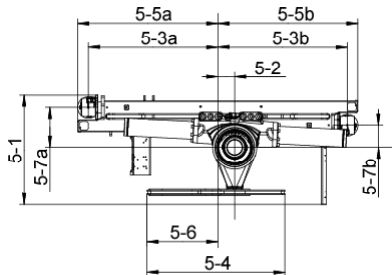

NOTE For specific values, see Table of Measurements

Chassis Installation

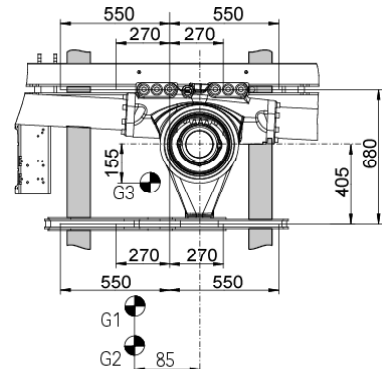

(1) Variable value depending on option.
 (2) Variations may occur depending on mounting position.

Load Diagram

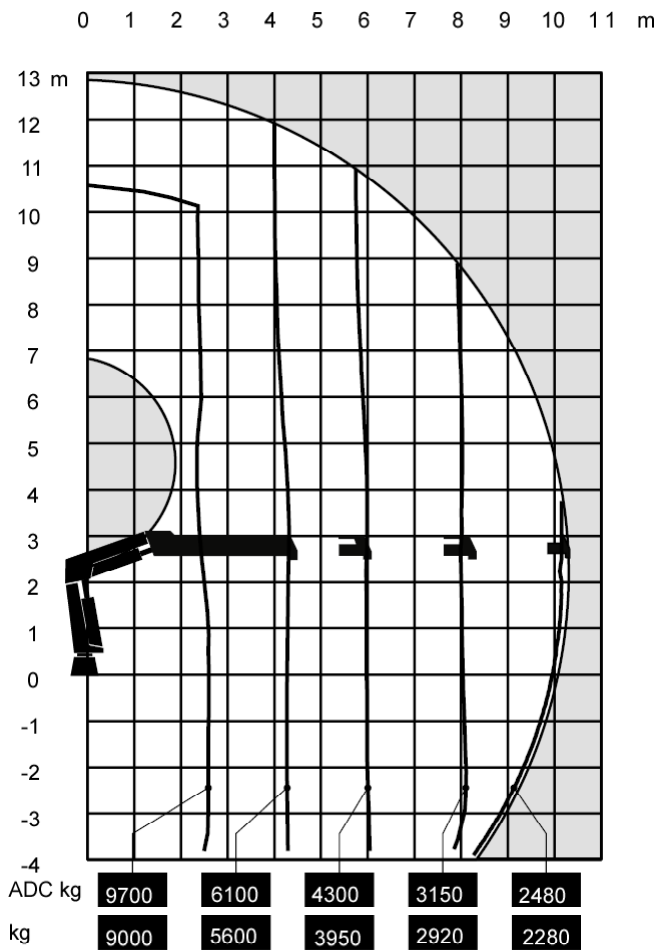

Capacity and performance

Lifting capacity with ADC	255.4 (kNm)
Lifting capacity	236.6 (kNm)
Standard lifting capacity at standard outreach with ADC	2.6 (m) - 9700 (kg) 4.3 (m) - 6100 (kg) 6.0 (m) - 4300 (kg) 8.0 (m) - 3150 (kg) 10.2 (m) - 2480 (kg)
Standard lifting capacity at standard outreach	2.6 (m) - 9000 (kg) 4.3 (m) - 5600 (kg) 6.0 (m) - 3950 (kg) 8.0 (m) - 2920 (kg) 10.2 (m) - 2280 (kg)
Manual lifting capacity at extension	12.5 (m) - 1940 (kg) 14.9 (m) - 1560 (kg)
Heavy lift capacity at heavy lift outreach	2.2 (m) - 11200 (kg)
Hydraulic boom extension	6.0 (m)
Manual max outreach	17.4 (m)
Lifting height above installation level hydraulic	12.9 (m)
Lifting height above installation level manual	17.5 (m)
Slewing torque	34 (kNm)
V80 Slewing speed	15 (°/s)
Slewing angle	420 (°)
Lifting speed	1.6 m/s

Functional demands

Recommended oilflow low	70 (l/min)
Recommended oilflow high	90 (l/min)
Working pressure	33 (MPa)
Max slope viable at full capacity	5 (°)

Weights and measurements

Height in folded position	2335 (mm)
Width in folded position	2495 (mm)
Installation space needed	1131 (mm)
Weight of crane	2840 (kg)
Weight support leg equipment	402 (kg)

Side View Unfolded Close in Area

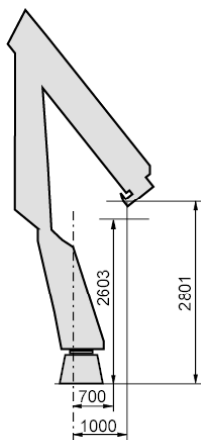

Side View Unfolded Stretched

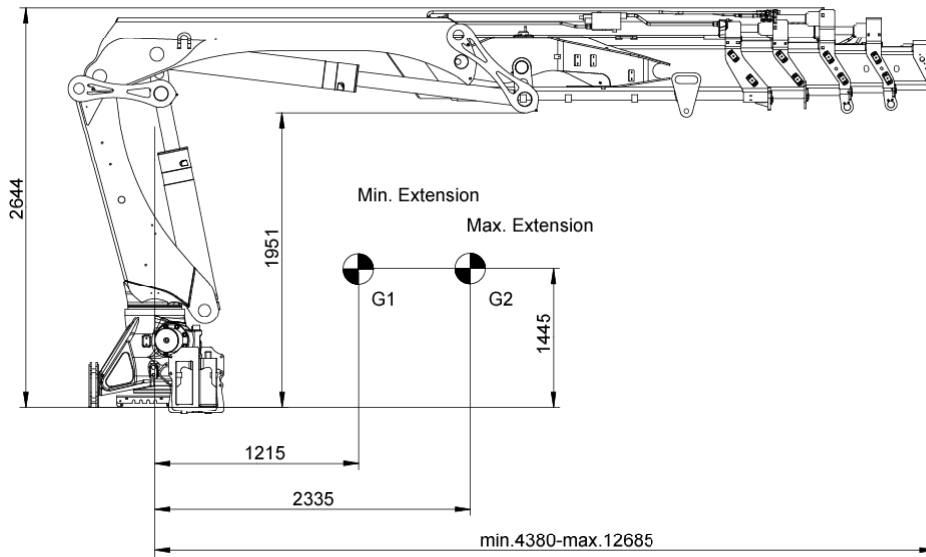

Side View Folded

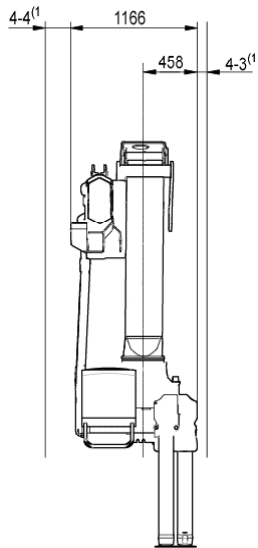

Front View Folded

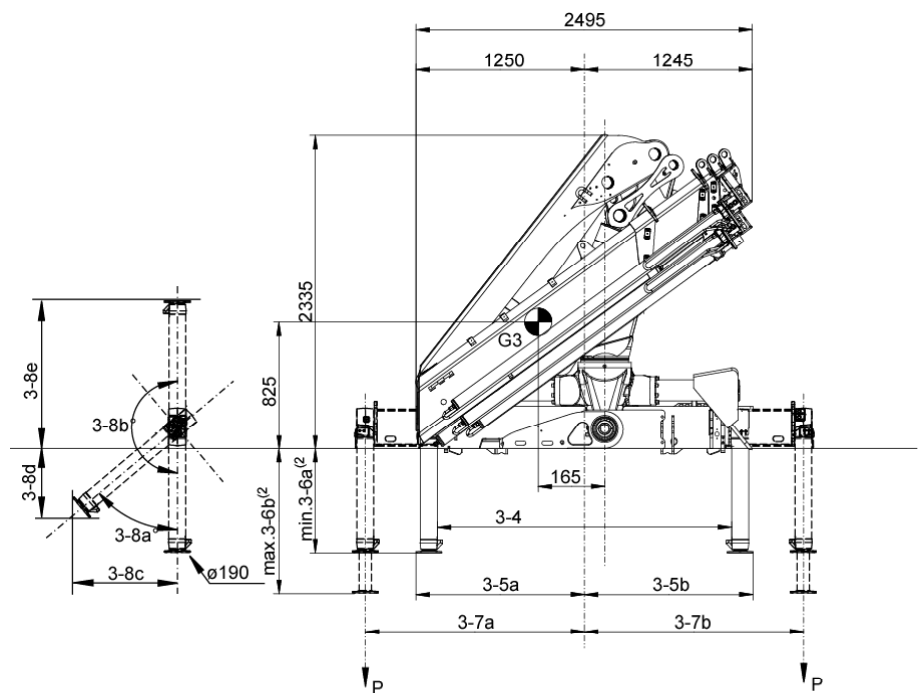

NOTE For specific values, see Table of Measurements

Top View Crane Base

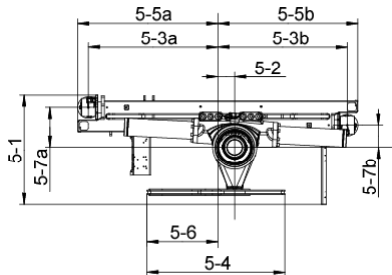

NOTE For specific values, see Table of Measurements

Chassis Installation

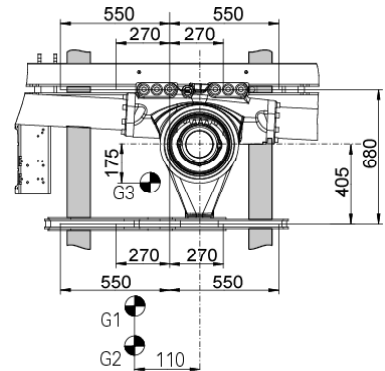

Load Diagram

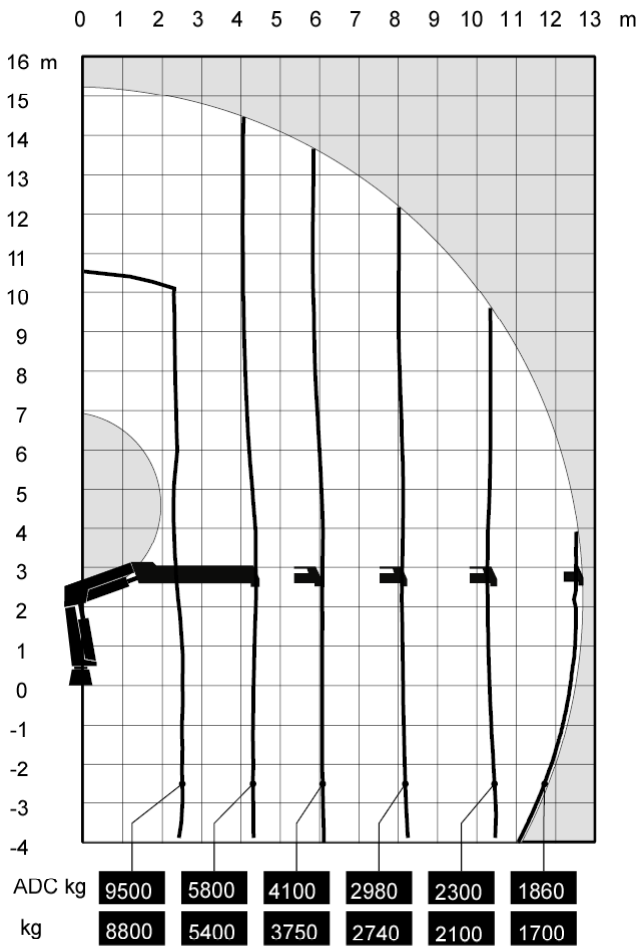

Side View Unfolded Close in Area

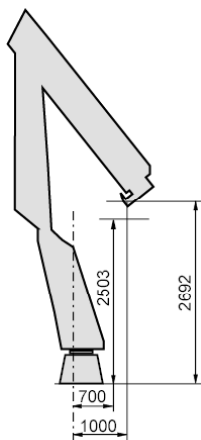

Capacity and performance

Lifting capacity with ADC	250.4 (kNm)
Lifting capacity	231.5 (kNm)
Standard lifting capacity at standard outreach with ADC	2.6 (m) - 9500 (kg)
	4.4 (m) - 5800 (kg)
	6.1 (m) - 4100 (kg)
	8.1 (m) - 2980 (kg)
	10.3 (m) - 2300 (kg)
	12.6 (m) - 1860 (kg)
Standard lifting capacity at standard outreach	2.6 (m) - 8800 (kg)
	4.4 (m) - 5400 (kg)
	6.1 (m) - 3750 (kg)
	8.1 (m) - 2740 (kg)
	10.3 (m) - 2100 (kg)
	12.6 (m) - 1700 (kg)
Manual lifting capacity at extension	15.0 (m) - 1480 (kg)
	17.2 (m) - 1240 (kg)
Heavy lift capacity at heavy lift outreach	2.2 (m) - 11100 (kg)
Hydraulic boom extension	8.3 (m)
Manual max outreach	17.4 (m)
Lifting height above installation level hydraulic	15.3 (m)
Lifting height above installation level manual	19.8 (m)
Slewing torque	34 (kNm)
V80 Slewing speed	15 (°/s)
Slewing angle	420 (°)
Lifting speed	2.0 (m/s)

Functional demands

Recommended oil flow low	70 (l/min)
Recommended oil flow high	90 (l/min)
Working pressure	33 (MPa)
Max slope viable at full capacity	5 (°)

Weights and measurements

Height in folded position	2335 (mm)
Width in folded position	2495 (mm)
Installation space needed	1166 (mm)
Weight of crane	3010 (kg)
Weight support leg equipment	402 (kg)

Side View Unfolded Stretched

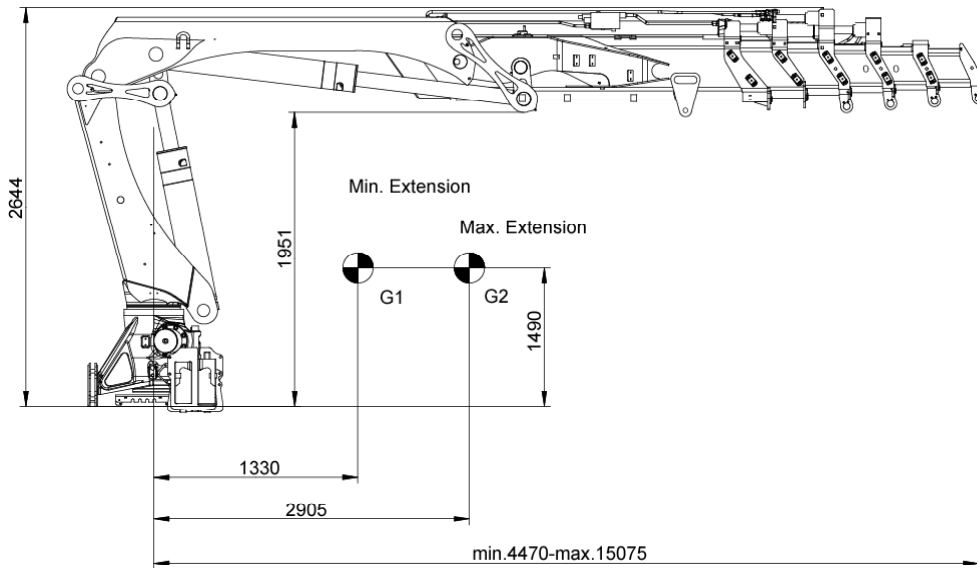

Side View Folded

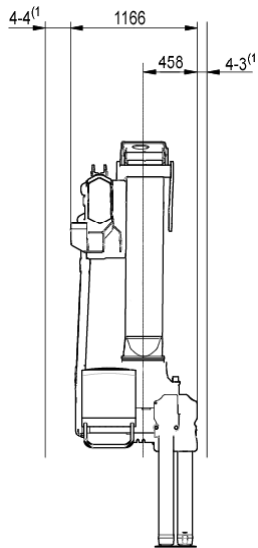

Front View Folded

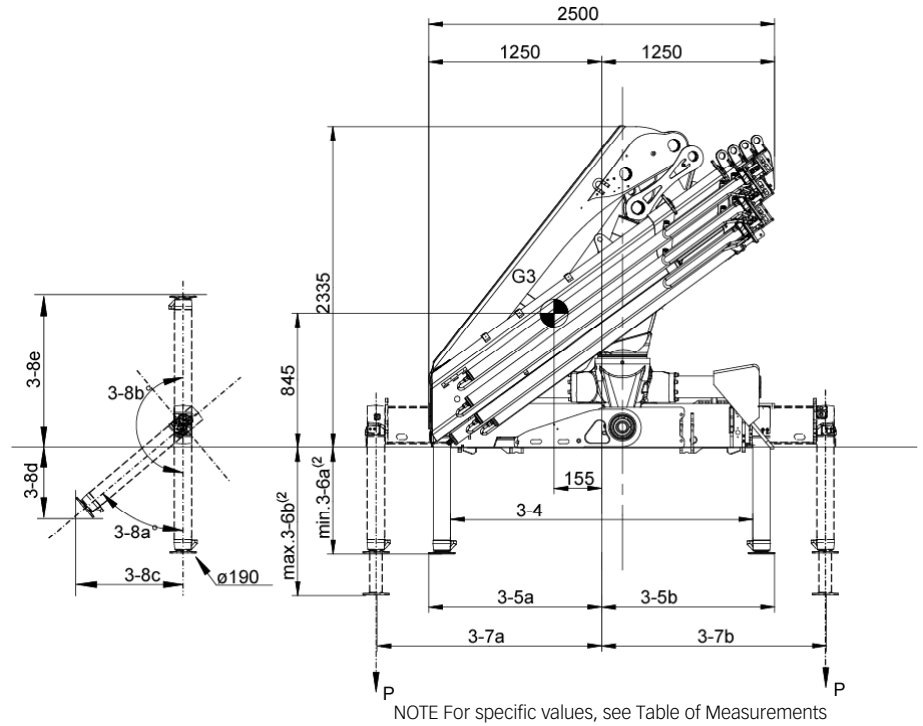

Top View Crane Base

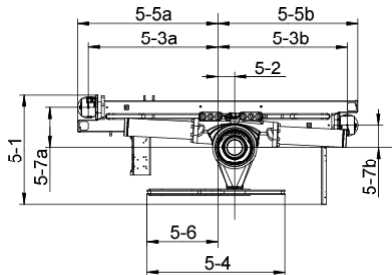

NOTE For specific values, see Table of Measurements

Chassis Installation

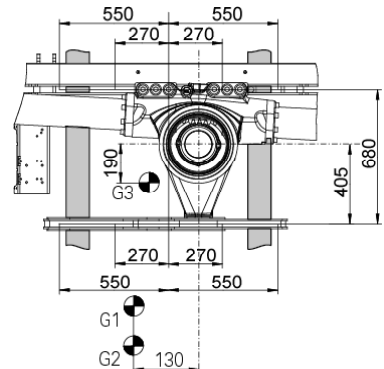

(1) Variable value depending on option.
 (2) Variations may occur depending on mounting position.

Load Diagram

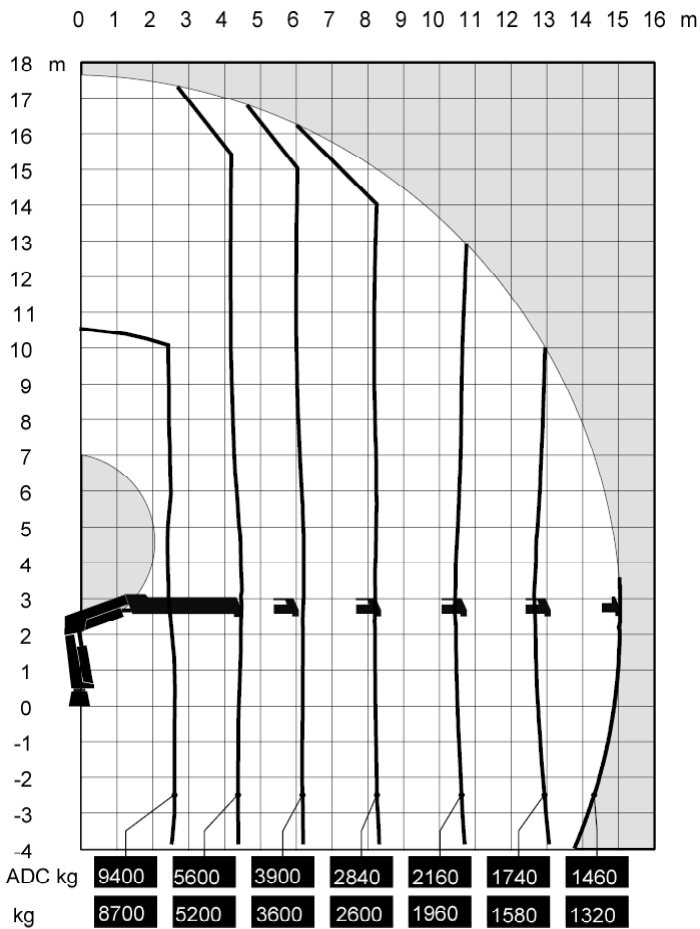

Capacity and performance

Lifting capacity with ADC	246.3 (kNm)
Lifting capacity	227.4 (kNm)
Standard lifting capacity at standard outreach with ADC	2.6 (m) - 9400 (kg) 4.5 (m) - 5600 (kg) 6.2 (m) - 3900 (kg) 8.2 (m) - 2840 (kg) 10.4 (m) - 2160 (kg) 12.7 (m) - 1740 (kg) 15.0 (m) - 1460 (kg)
Standard lifting capacity at standard outreach	2.6 (m) - 8700 (kg) 4.5 (m) - 5200 (kg) 6.2 (m) - 3600 (kg) 8.2 (m) - 2600 (kg) 10.4 (m) - 1960 (kg) 12.7 (m) - 1580 (kg) 15.0 (m) - 1320 (kg)
Manual lifting capacity at extension	17.2 (m) - 1200 (kg)
Heavy lift capacity at heavy lift outreach	2.2 (m) - 10900 (kg)
Hydraulic boom extension	10.6 (m)
Manual max outreach	17.4 (m)
Lifting height above installation level hydraulic	17.7 (m)
Lifting height above installation level manual	19.8 (m)
Slewing torque	34 (kNm)
V80 Slewing speed	15 (°/s)
Slewing angle	420 (°)
Lifting speed	2.3 (m/s)

Functional demands

Recommended oil flow low	70 (l/min)
Recommended oil flow high	90 (l/min)
Working pressure	33 (MPa)
Max slope viable at full capacity	5 (°)

Weights and measurements

Height in folded position	2335 (mm)
Width in folded position	2500 (mm)
Installation space needed	1166 (mm)
Weight of crane	3150 (kg)
Weight support leg equipment	402 (kg)

Side View Unfolded Close in Area

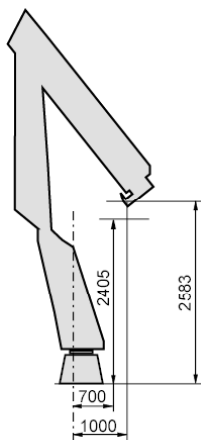

Side View Unfolded Stretched

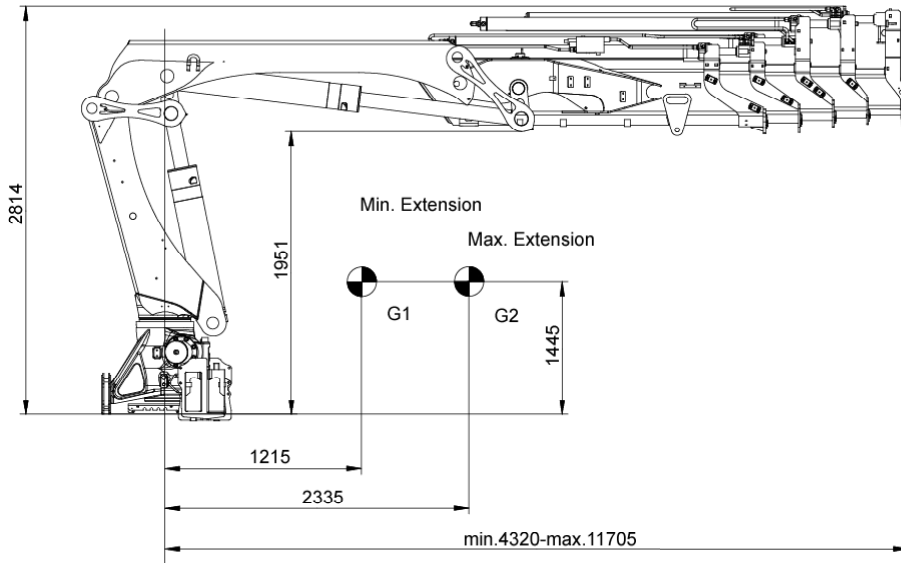

Side View Folded

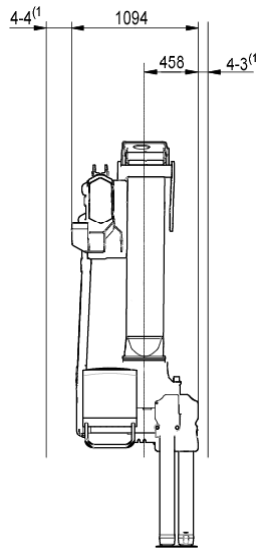

Front View Folded

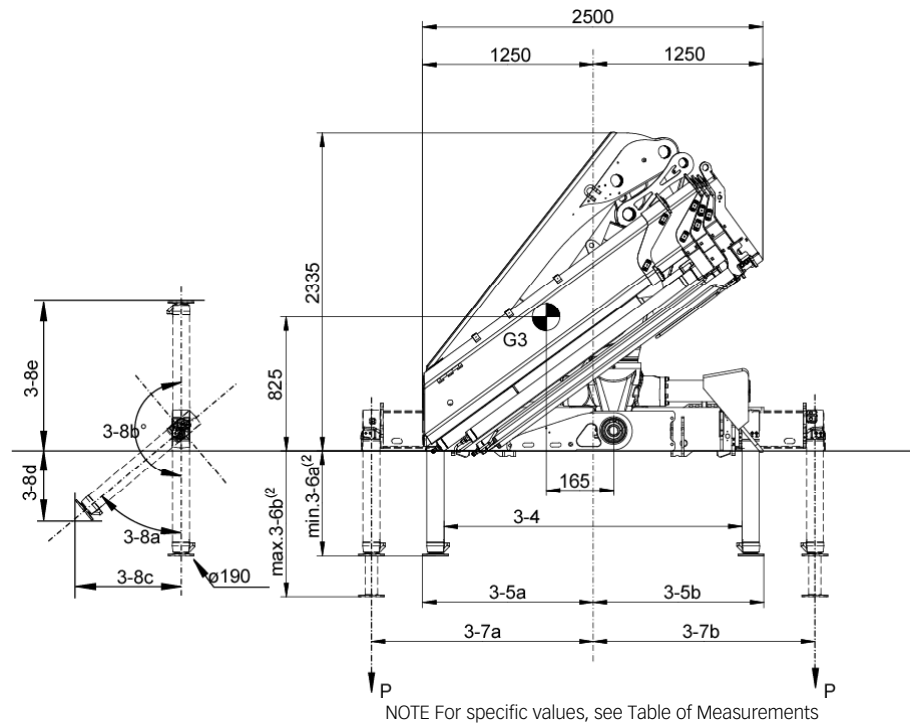

Top View Crane Base

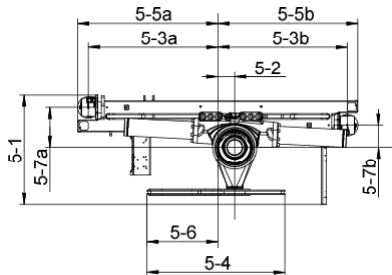

NOTE For specific values, see Table of Measurements

Chassis Installation

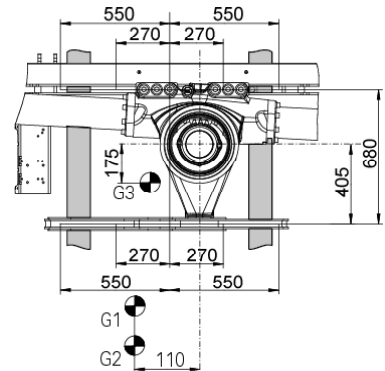

(1) Variable value depending on option.
 (2) Variations may occur depending on mounting position.

Load Diagram

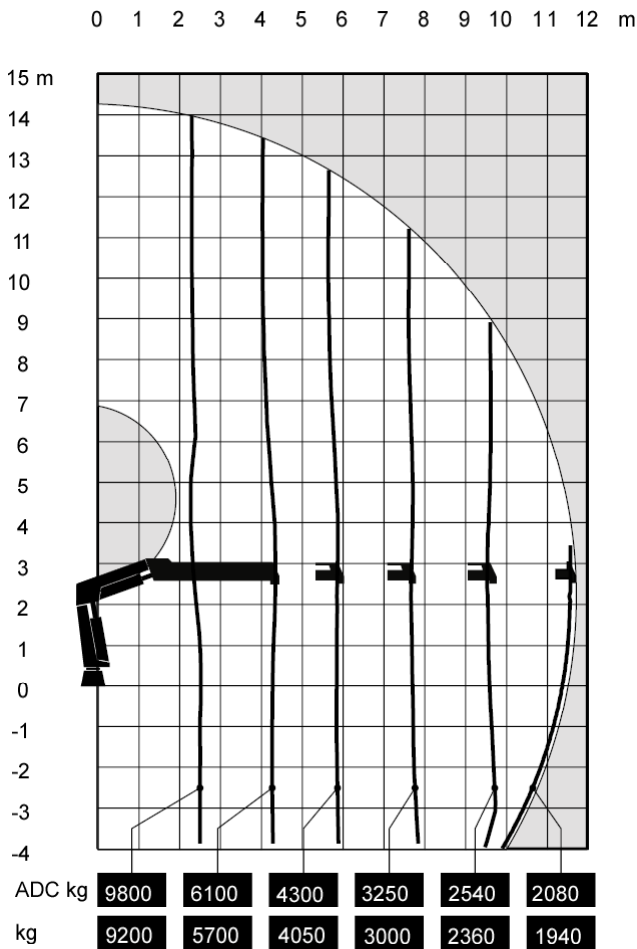

Side View Unfolded Close in Area

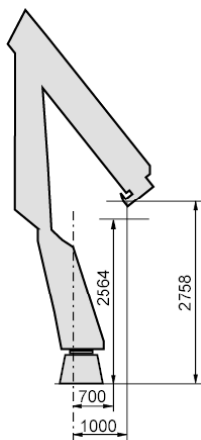

Capacity and performance

Lifting capacity with ADC	256.4 (kNm)
Lifting capacity	239.7 (kNm)
Standard lifting capacity at standard outreach with ADC	2.6 (m) - 9800 (kg)
	4.3 (m) - 6100 (kg)
	5.9 (m) - 4300 (kg)
	7.7 (m) - 3250 (kg)
	9.6 (m) - 2540 (kg)
	11.6 (m) - 2080 (kg)
Standard lifting capacity at standard outreach	2.6 (m) - 9200 (kg)
	4.3 (m) - 5700 (kg)
	5.9 (m) - 4050 (kg)
	7.7 (m) - 3000 (kg)
	9.6 (m) - 2360 (kg)
	11.6 (m) - 1940 (kg)
Manual lifting capacity at extension	13.7 (m) - 1700 (kg)
	15.9 (m) - 1400 (kg)
Heavy lift capacity at heavy lift outreach	2.2 (m) - 11300 (kg)
Hydraulic boom extension	7.4 (m)
Manual max outreach	18.6 (m)
Lifting height above installation level hydraulic	14.3 (m)
Lifting height above installation level manual	18.5 (m)
Slewing torque	34 (kNm)
V80 Slewing speed	15 (°/s)
Slewing angle	420 (°)
Lifting speed	1.5 m/s

Functional demands

Recommended oil flow low	90 (l/min)
Recommended oil flow high	120 (l/min)
Working pressure	34 (MPa)
Max slope viable at full capacity	5 (°)

Weights and measurements

Height in folded position	2335 (mm)
Width in folded position	2500 (mm)
Installation space needed	1094 (mm)
Weight of crane	3130 (kg)
Weight support leg equipment	402 (kg)

Side View Unfolded Stretched

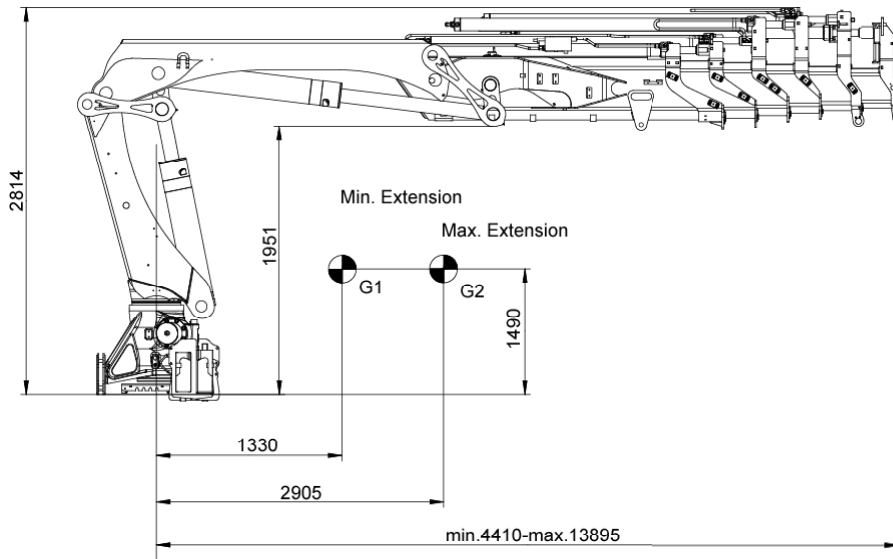

Side View Folded

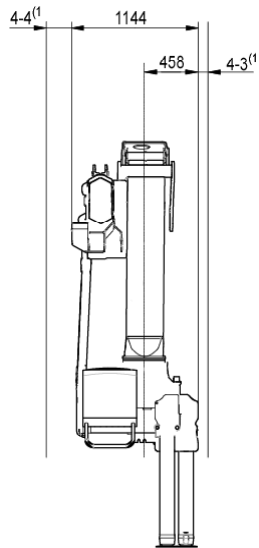

Front View Folded

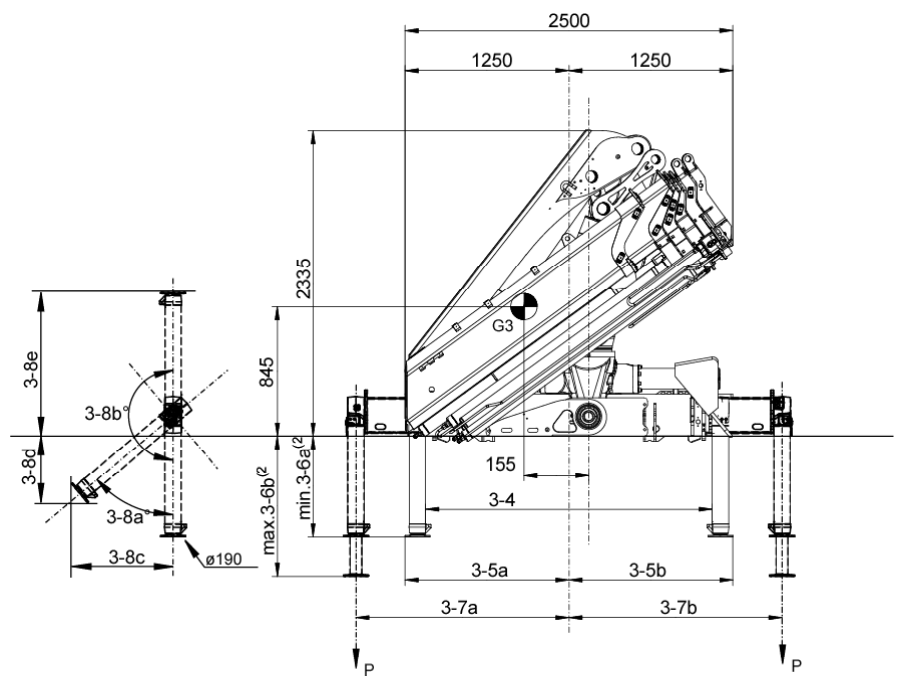

NOTE For specific values, see Table of Measurements

Top View Crane Base

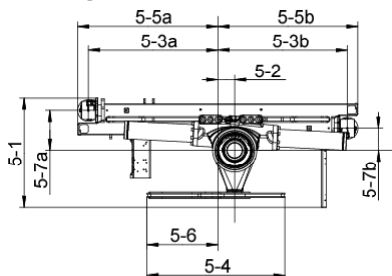

NOTE For specific values, see Table of Measurements

Chassis Installation

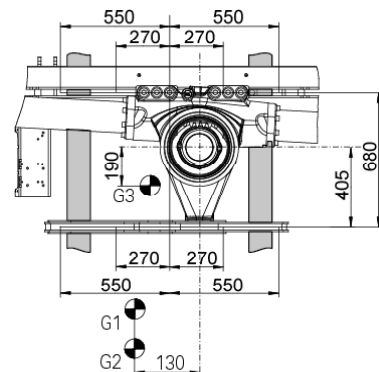

(1) Variable value depending on option.
 (2) Variations may occur depending on mounting position.

Load Diagram

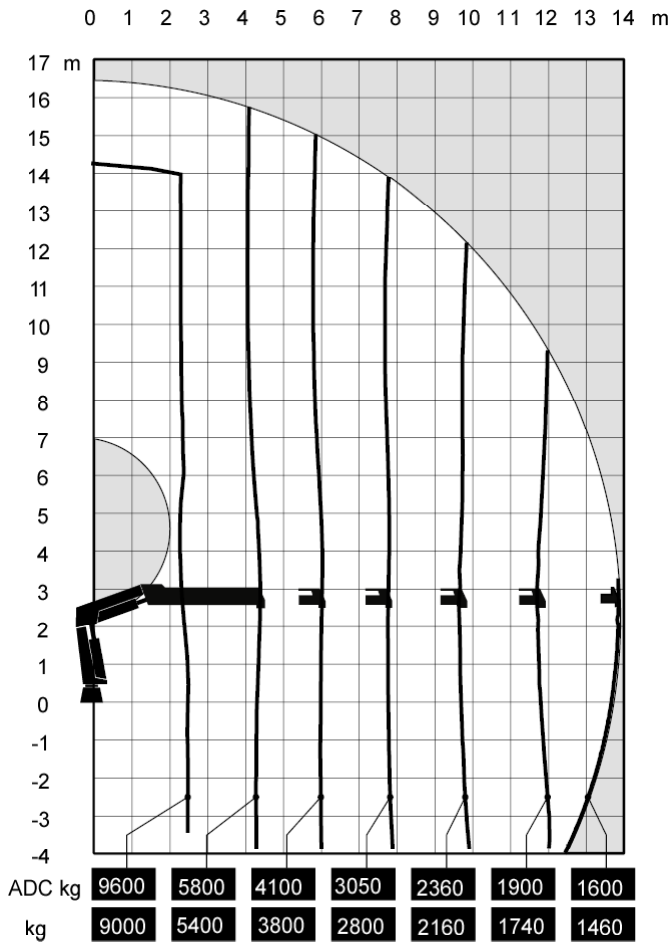

Capacity and performance

Lifting capacity with ADC	250.8 (kNm)
Lifting capacity	234 (kNm)
Standard lifting capacity at standard outreach with ADC	2.6 (m) - 9600 (kg) 4.4 (m) - 5800 (kg) 6.0 (m) - 4100 (kg) 7.8 (m) - 3050 (kg) 9.7 (m) - 2360 (kg) 11.7 (m) - 1900 (kg) 13.8 (m) - 1600 (kg)
Standard lifting capacity at standard outreach	2.6 (m) - 9000 (kg) 4.4 (m) - 5400 (kg) 6.0 (m) - 3800 (kg) 7.8 (m) - 2800 (kg) 9.7 (m) - 2160 (kg) 11.7 (m) - 1740 (kg) 13.8 (m) - 1460 (kg)
Manual lifting capacity at extension	15.8 (m) - 1320 (kg) 17.5 (m) - 1140 (kg)
Heavy lift capacity at heavy lift outreach	2.2 (m) - 11100 (kg)
Hydraulic boom extension	9.5 (m)
Manual max outreach	21.0 (m)
Lifting height above installation level hydraulic	16.5 (m)
Lifting height above installation level manual	20.1 (m)
Slewing torque	34 (kNm)
V80 Slewing speed	15 (°/s)
Slewing angle	420 (°)
Lifting speed	1.8 (m/s)

Functional demands

Recommended oil flow low	90 (l/min)
Recommended oil flow high	120 (l/min)
Working pressure	34 (MPa)
Max slope viable at full capacity	5 (°)

Weights and measurements

Height in folded position	2335 (mm)
Width in folded position	2500 (mm)
Installation space needed	1144 (mm)
Weight of crane	3310 (kg)
Weight support leg equipment	402 (kg)

Side View Unfolded Close in Area

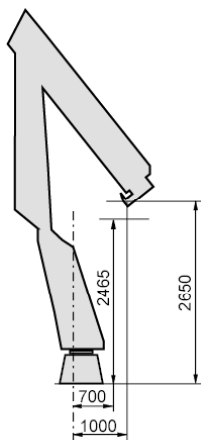

Side View Unfolded Stretched

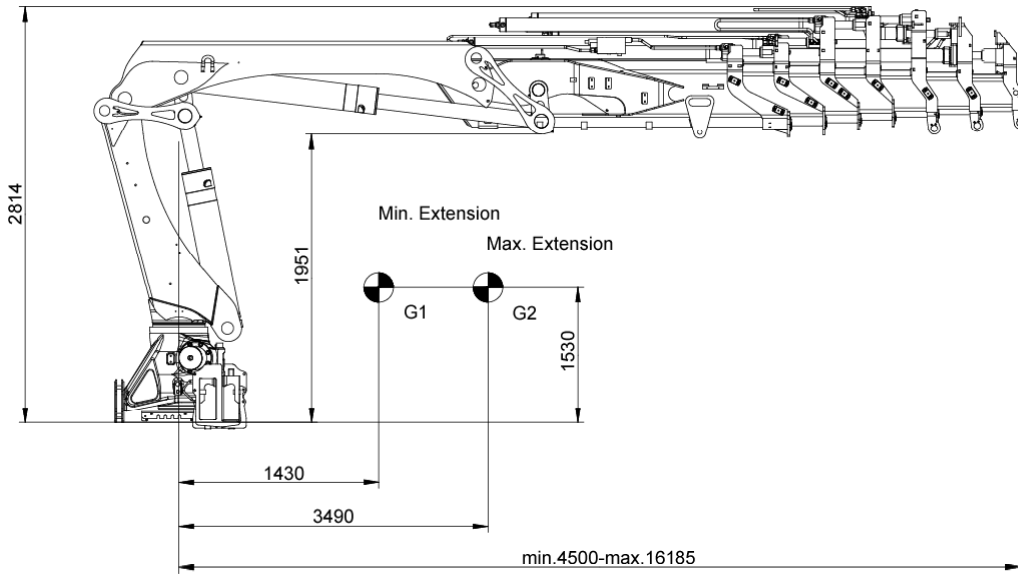

Side View Folded

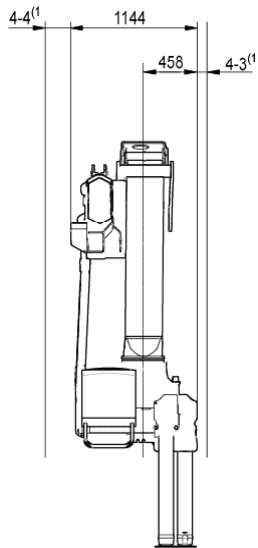

Front View Folded

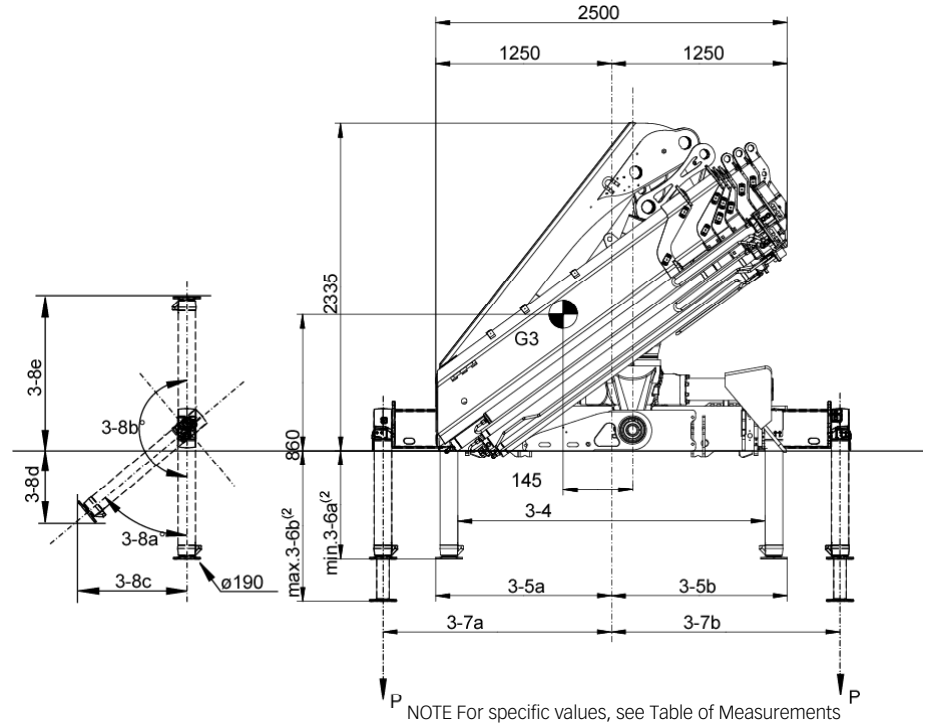

Top View Crane Base

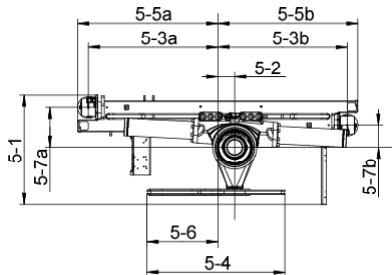

NOTE For specific values, see Table of Measurements

Chassis Installation

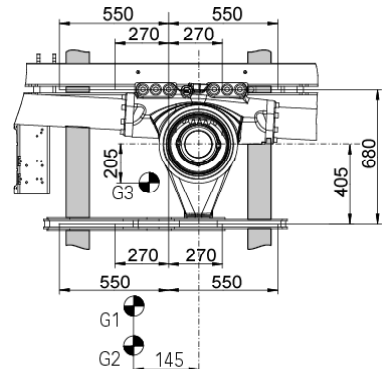

(1) Variable value depending on option.
 (2) Variations may occur depending on mounting position.

Load Diagram

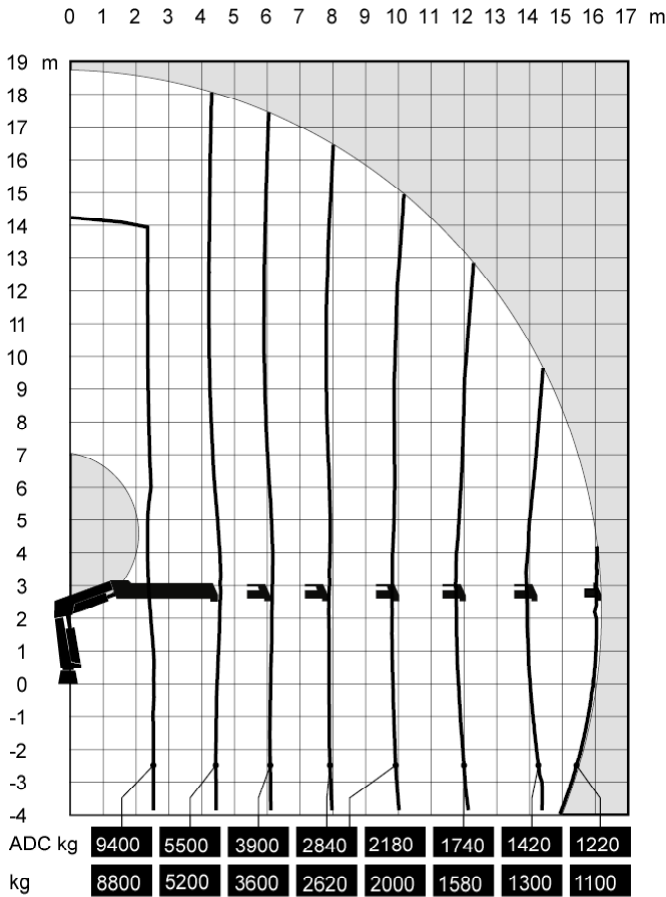

Capacity and performance

Lifting capacity with ADC	245.3 (kNm)
Lifting capacity	228.5 (kNm)
Standard lifting capacity at standard outreach with ADC	2.6 (m) - 9400 (kg) 4.5 (m) - 5500 (kg) 6.1 (m) - 3900 (kg) 7.9 (m) - 2840 (kg) 9.8 (m) - 2180 (kg) 11.8 (m) - 1740 (kg) 13.9 (m) - 1420 (kg) 16.1 (m) - 1220 (kg)
Standard lifting capacity at standard outreach	2.6 (m) - 8800 (kg) 4.5 (m) - 5200 (kg) 6.1 (m) - 3600 (kg) 7.9 (m) - 2620 (kg) 9.8 (m) - 2000 (kg) 11.8 (m) - 1580 (kg) 13.9 (m) - 1300 (kg) 16.1 (m) - 1100 (kg)
Manual lifting capacity at extension	18.3 (m) - 980 (kg) 20.4 (m) - 840 (kg)
Heavy lift capacity at heavy lift outreach	2.2 (m) - 10900 (kg)
Hydraulic boom extension	11.7 (m)
Manual max outreach	23.3 (m)
Lifting height above installation level hydraulic	18.8 (m)
Lifting height above installation level manual	23.1 (m)
Slewing torque	34 (kNm)
V80 Slewing speed	15 (°/s)
Slewing angle	420 (°)
Lifting speed	2.1 m/s

Side View Unfolded Close in Area

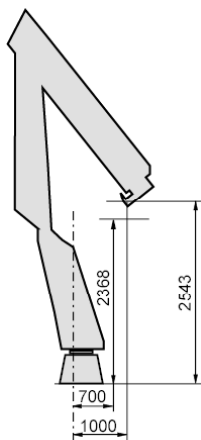

Functional demands

Recommended oil flow low	90 (l/min)
Recommended oil flow high	120 (l/min)
Working pressure	34 (MPa)
Max slope viable at full capacity	5 (°)

Weights and measurements

Height in folded position	2335 (mm)
Width in folded position	2500 (mm)
Installation space needed	1144 (mm)
Weight of crane	3480 (kg)
Weight support leg equipment	402 (kg)

Side View Unfolded Stretched

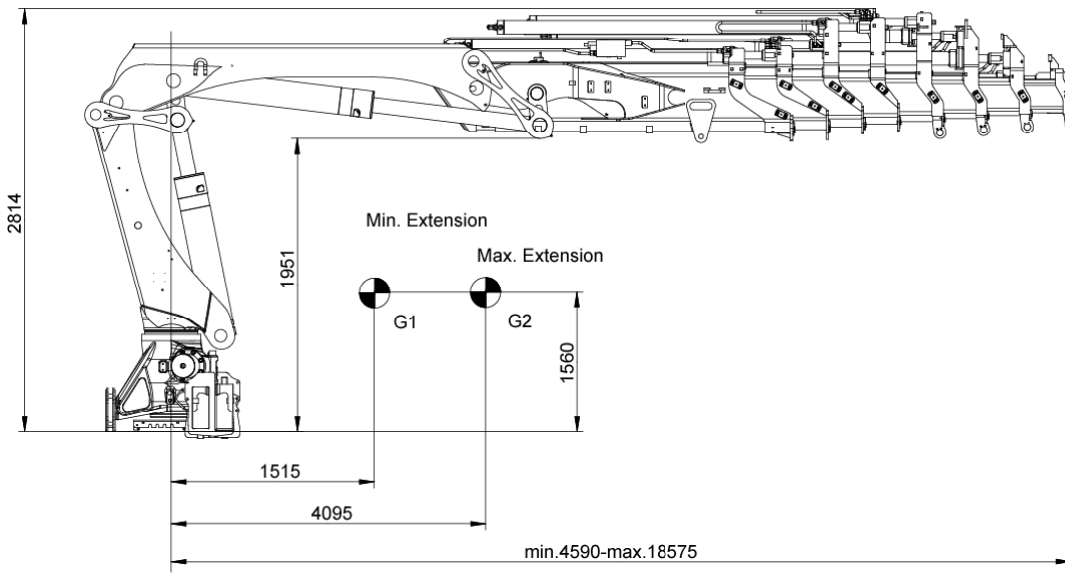

Side View Folded

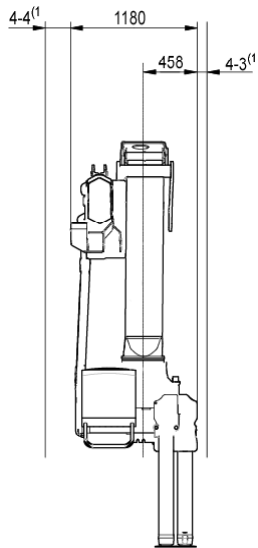

Front View Folded

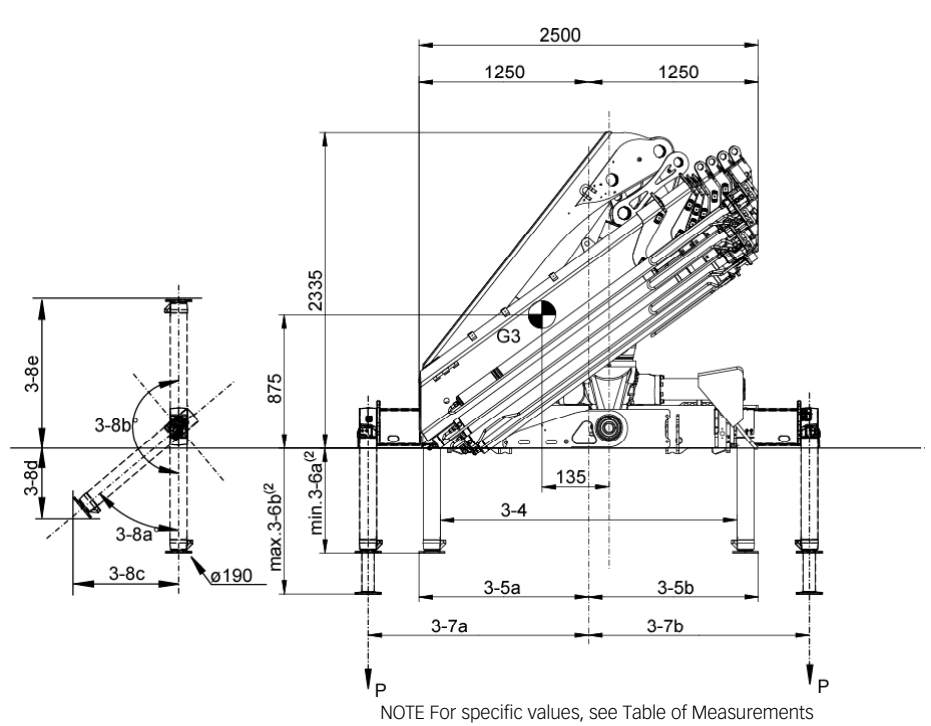

Top View Crane Base

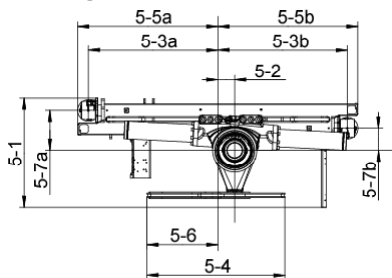

NOTE For specific values, see Table of Measurements

Chassis Installation

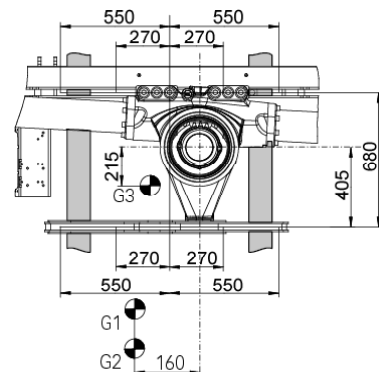

(1) Variable value depending on option.
 (2) Variations may occur depending on mounting position.

Load Diagram

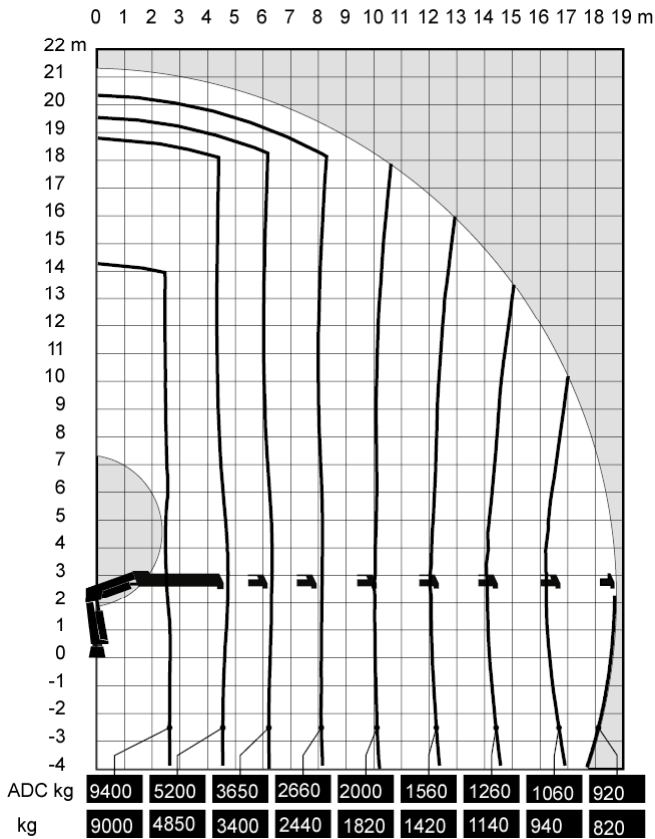

Side View Unfolded Close in Area

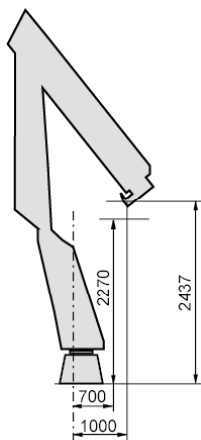

Capacity and performance

Lifting capacity with ADC	241.5 (kNm)
Lifting capacity	224.6 (kNm)
Standard lifting capacity at standard outreach with ADC	2.5 (m) - 9400 (kg) 4.7 (m) - 5200 (kg) 6.3 (m) - 3650 (kg) 8.1 (m) - 2660 (kg) 10.0 (m) - 2000 (kg) 12.0 (m) - 1560 (kg) 14.1 (m) - 1260 (kg) 16.3 (m) - 1060 (kg) 18.6 (m) - 920 (kg)
Standard lifting capacity at standard outreach	2.5 (m) - 9000 (kg) 4.7 (m) - 4850 (kg) 6.3 (m) - 3400 (kg) 8.1 (m) - 2440 (kg) 10.0 (m) - 1820 (kg) 12.0 (m) - 1420 (kg) 14.1 (m) - 1140 (kg) 16.3 (m) - 940 (kg) 18.6 (m) - 820 (kg)
Manual lifting capacity at extension	20.1 (m) - 780 (kg) 21.6 (m) - 680 (kg)
Heavy lift capacity at heavy lift outreach	2.2 (m) - 10800 (kg)
Hydraulic boom extension	14.0 (m)
Manual max outreach	23.2 (m)
Lifting height above installation level hydraulic	21.2 (m)
Lifting height above installation level manual	24.2 (m)
Slewing torque	34 (kNm)
V80 Slewing speed	15 (°/s)
Slewing angle	420 (°)
Lifting speed	2.4 (m/s)

Functional demands

Recommended oil flow low	90 (l/min)
Recommended oil flow high	120 (l/min)
Working pressure	34 (MPa)
Max slope viable at full capacity	5 (°)

Weights and measurements

Height in folded position	2335 (mm)
Width in folded position	2500 (mm)
Installation space needed	1180 (mm)
Weight of crane	3630 (kg)
Weight support leg equipment	402 (kg)

Side View Unfolded Stretched

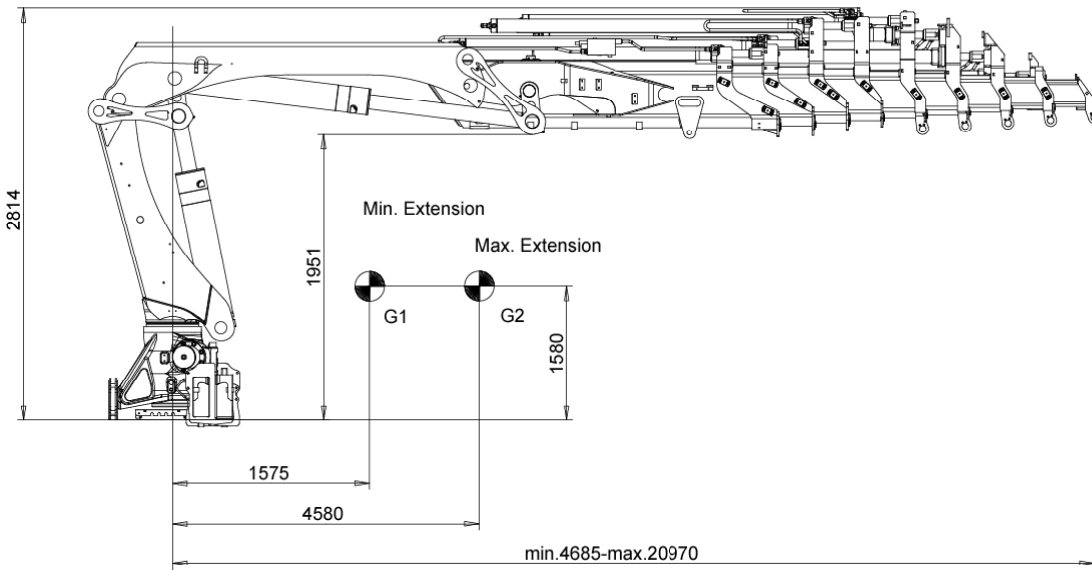

Side View Folded

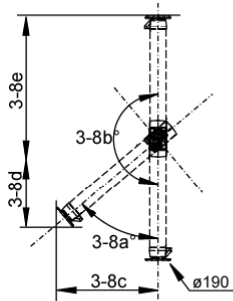
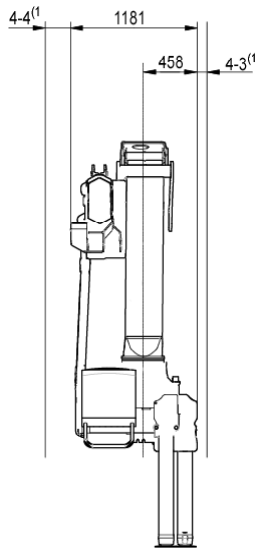

Front View Folded

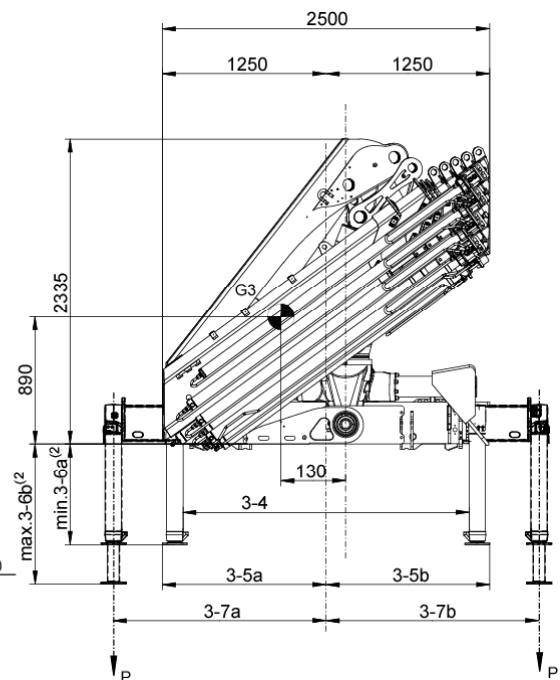

NOTE For specific values, see Table of Measurements

Top View Crane Base

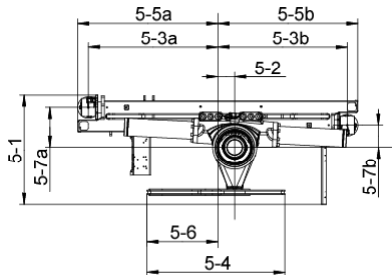

NOTE For specific values, see Table of Measurements

Chassis Installation

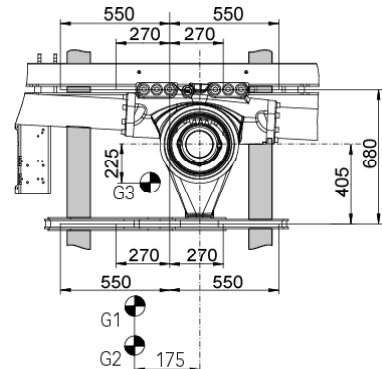

Load Diagram

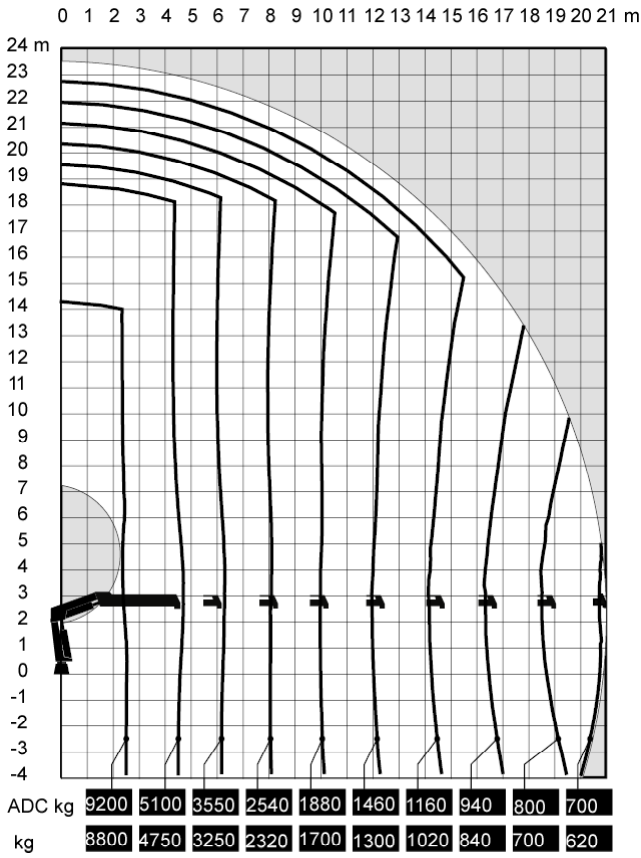

Capacity and performance

Lifting capacity with ADC	236.3 (kNm)
Lifting capacity	219.4 (kNm)
Standard lifting capacity at standard outreach with ADC	2.5 (m) - 9200 (kg) 4.7 (m) - 5100 (kg) 6.3 (m) - 3550 (kg) 8.1 (m) - 2540 (kg) 10.0 (m) - 1880 (kg) 12.0 (m) - 1460 (kg) 14.1 (m) - 1160 (kg) 16.3 (m) - 940 (kg) 18.6 (m) - 800 (kg) 20.9 (m) - 700 (kg)
Standard lifting capacity at standard outreach	2.5 (m) - 8800 (kg) 4.7 (m) - 4750 (kg) 6.3 (m) - 3250 (kg) 8.1 (m) - 2320 (kg) 10.0 (m) - 1700 (kg) 12.0 (m) - 1300 (kg) 14.1 (m) - 1020 (kg) 16.3 (m) - 840 (kg) 18.6 (m) - 700 (kg) 20.9 (m) - 620 (kg)
Manual lifting capacity at extension	22.4 (m) - 600 (kg)
Heavy lift capacity at heavy lift outreach	2.2 (m) - 10600 (kg)
Hydraulic boom extension	16.3 (m)
Manual max outreach	23.3 (m)
Lifting height above installation level hydraulic	23.6 (m)
Lifting height above installation level manual	25.1 (m)
Slewing torque	34 (kNm)
V80 Slewing speed	15 (°/s)
Slewing angle	420 (°)
Lifting speed	2.7 m/s

Side View Unfolded Close in Area

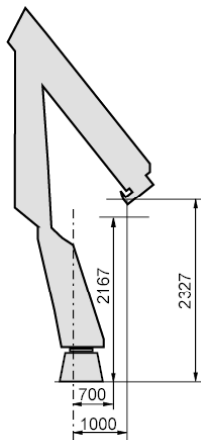

Functional demands

Recommended oil flow low	90 (l/min)
Recommended oil flow high	120 (l/min)
Working pressure	34 (MPa)
Max slope viable at full capacity	5 (°)

Weights and measurements

Height in folded position	2335 (mm)
Width in folded position	2500 (mm)
Installation space needed	1181 (mm)
Weight of crane	3750 (kg)
Weight support leg equipment	402 (kg)

Side View Unfolded Stretched

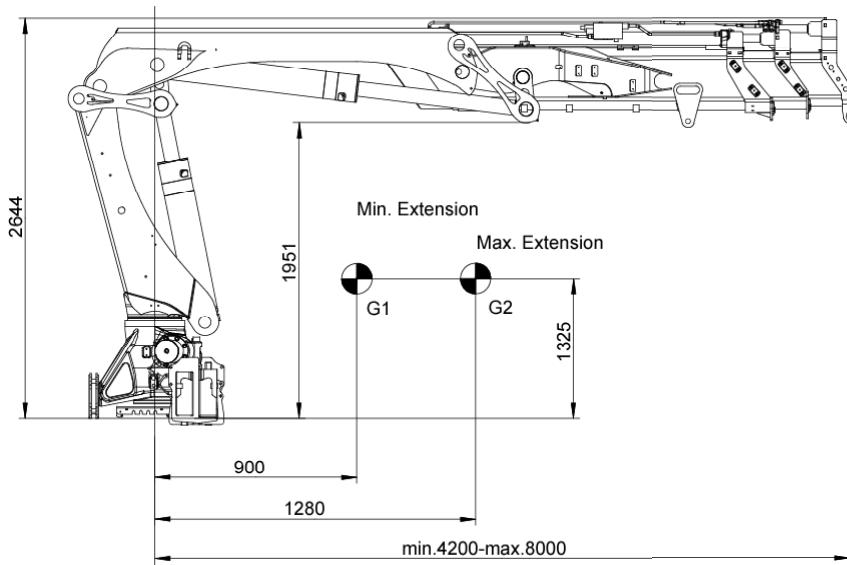

Side View Folded

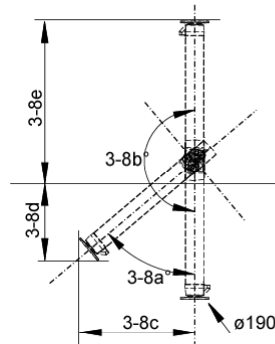
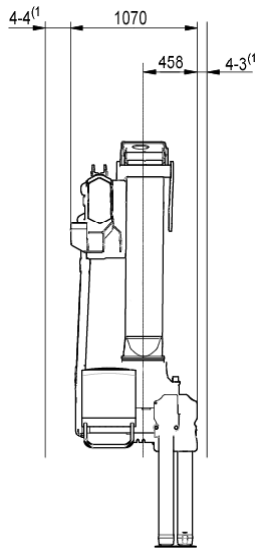

Front View Folded

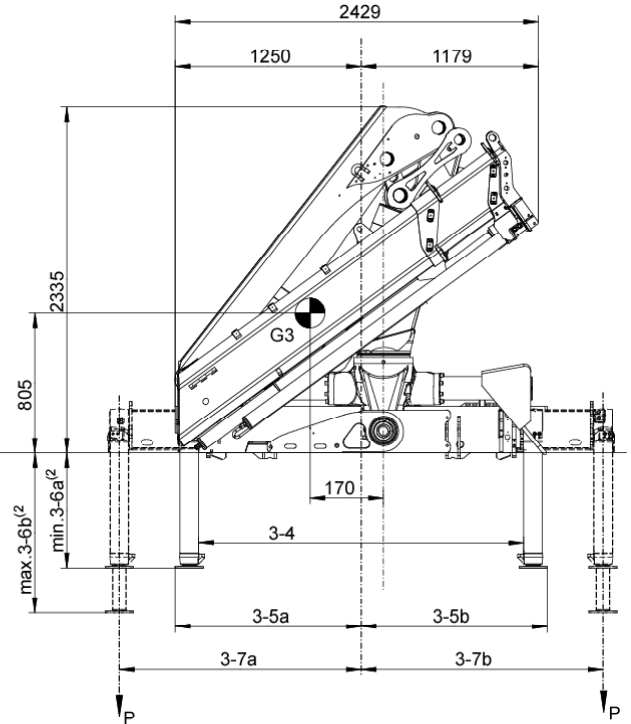

NOTE For specific values, see Table of Measurements

Top View Crane Base

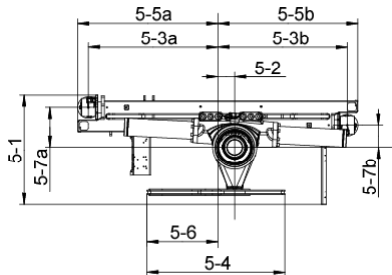

NOTE For specific values, see Table of Measurements

Chassis Installation

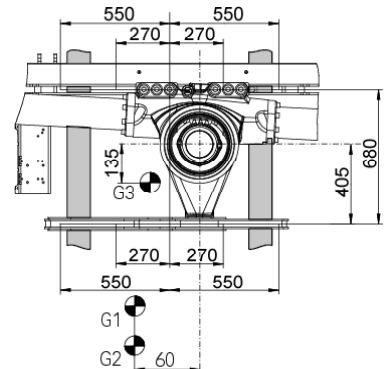

(1) Variable value depending on option.
 (2) Variations may occur depending on mounting position.

Load Diagram

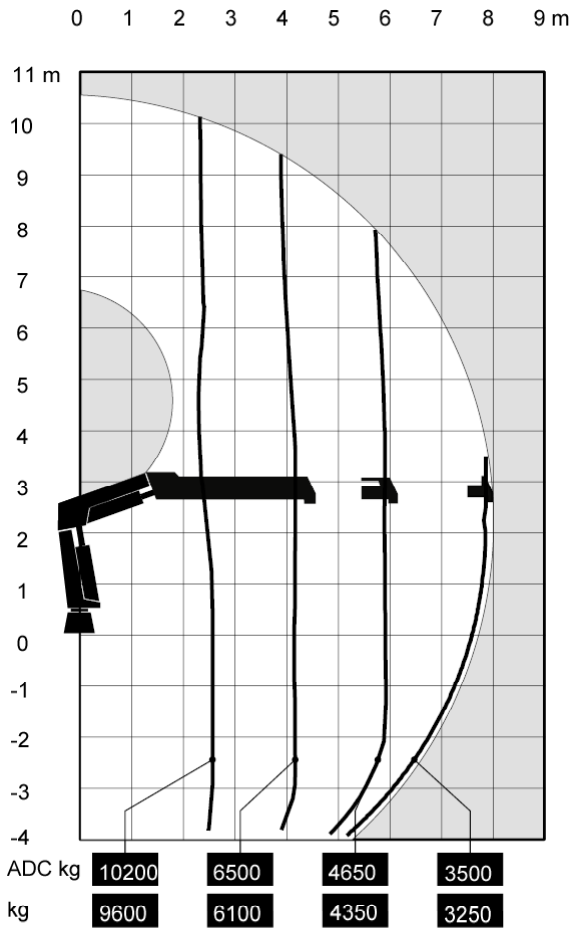

Capacity and performance

Lifting capacity with ADC	270.5 (kNm)
Lifting capacity	253.1 (kNm)
Standard lifting capacity at standard outreach with ADC	2.6 (m) - 10200 (kg)
	4.2 (m) - 6500 (kg)
	5.9 (m) - 4650 (kg)
	7.9 (m) - 3500 (kg)
Standard lifting capacity at standard outreach	2.6 (m) - 9600 (kg)
	4.2 (m) - 6100 (kg)
	5.9 (m) - 4350 (kg)
	7.9 (m) - 3250 (kg)
Manual lifting capacity at extension	10.1 (m) - 2660 (kg)
	12.5 (m) - 2080 (kg)
Heavy lift capacity at heavy lift outreach	2.2 (m) - 11800 (kg)
Hydraulic boom extension	3.8 (m)
Manual max outreach	15.1 (m)
Lifting height above installation level hydraulic	10.6 (m)
Lifting height above installation level manual	15.1 (m)
Slewing torque	34 (kNm)
V80 Slewing speed	15 (°/s)
Slewing angle	420 (°)
Lifting speed	1.0 m/s

Functional demands

Recommended oilflow low	90 (l/min)
Recommended oilflow high	120 (l/min)
Working pressure	34 (MPa)
Max slope viable at full capacity	5 (°)

Weights and measurements

Height in folded position	2335 (mm)
Width in folded position	2429 (mm)
Installation space needed	1070 (mm)
Weight of crane	2700 (kg)
Weight support leg equipment	402 (kg)

Side View Unfolded Close in Area

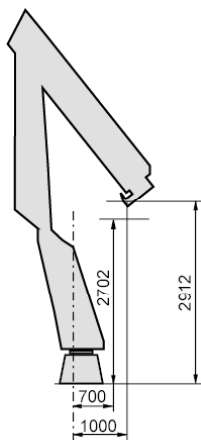

Side View Unfolded Stretched

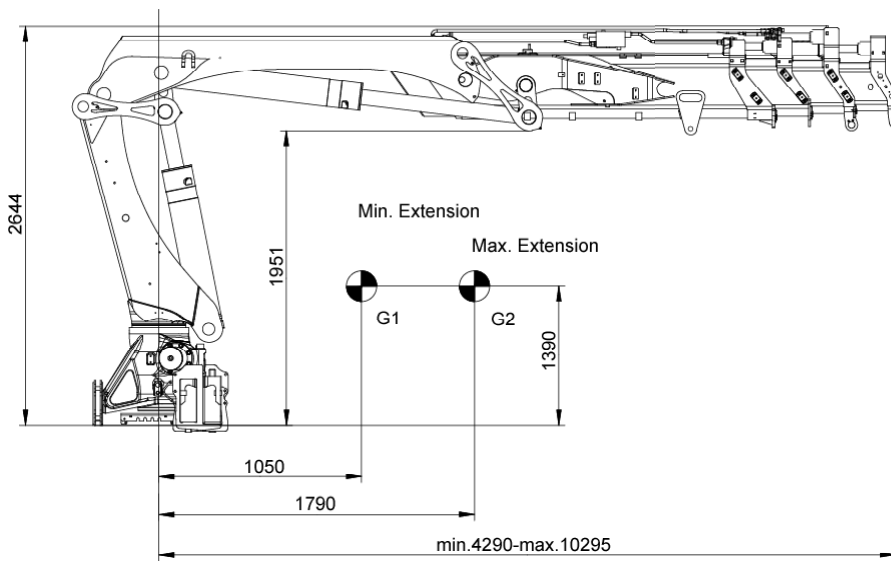

Side View Folded

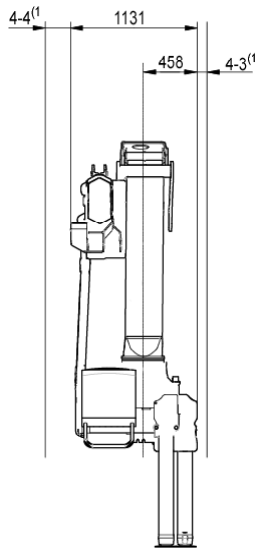

Front View Folded

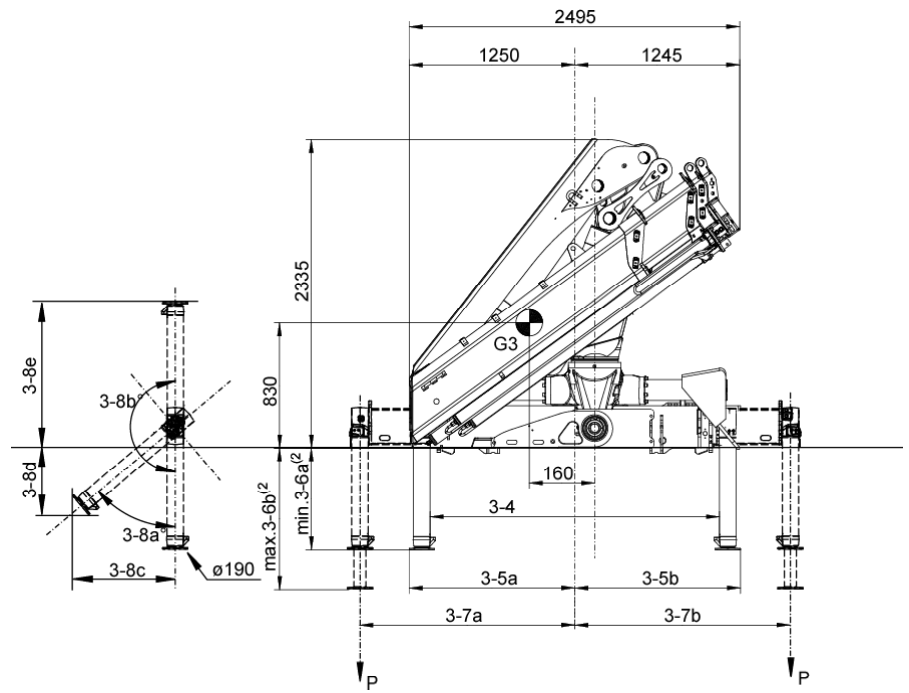

NOTE For specific values, see Table of Measurements

Top View Crane Base

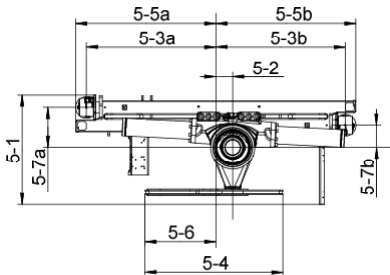

NOTE For specific values, see Table of Measurements

Chassis Installation

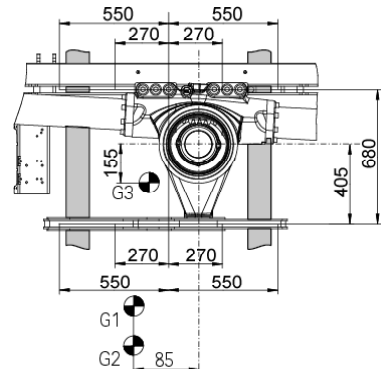

(1) Variable value depending on option.
 (2) Variations may occur depending on mounting position.

Load Diagram

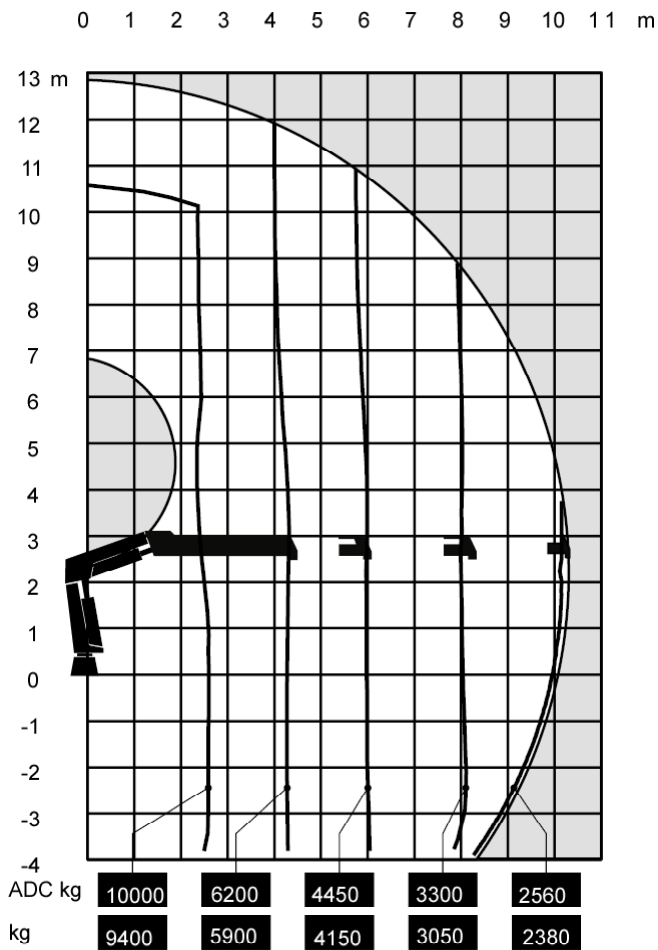

Capacity and performance

Lifting capacity with ADC	263.6 (kNm)
Lifting capacity	246.8 (kNm)
Standard lifting capacity at standard outreach with ADC	2.6 (m) - 10000 (kg) 4.3 (m) - 6200 (kg) 6.0 (m) - 4450 (kg) 8.0 (m) - 3300 (kg) 10.2 (m) - 2560 (kg)
Standard lifting capacity at standard outreach	2.6 (m) - 9400 (kg) 4.3 (m) - 5900 (kg) 6.0 (m) - 4150 (kg) 8.0 (m) - 3050 (kg) 10.2 (m) - 2380 (kg)
Manual lifting capacity at extension	12.5 (m) - 2020 (kg) 14.9 (m) - 1620 (kg)
Heavy lift capacity at heavy lift outreach	2.2 (m) - 11600 (kg)
Hydraulic boom extension	6.0 (m)
Manual max outreach	17.4 (m)
Lifting height above installation level hydraulic	12.9 (m)
Lifting height above installation level manual	17.5 (m)
Slewing torque	34 (kNm)
V80 Slewing speed	15 (°/s)
Slewing angle	420 (°)
Lifting speed	1.3 m/s

Functional demands

Recommended oilflow low	90 (l/min)
Recommended oilflow high	120 (l/min)
Working pressure	34 (MPa)
Max slope viable at full capacity	5 (°)

Weights and measurements

Height in folded position	2335 (mm)
Width in folded position	2495 (mm)
Installation space needed	1131 (mm)
Weight of crane	2900 (kg)
Weight support leg equipment	402 (kg)

Side View Unfolded Close in Area

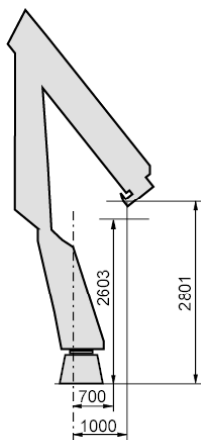

Side View Unfolded Stretched

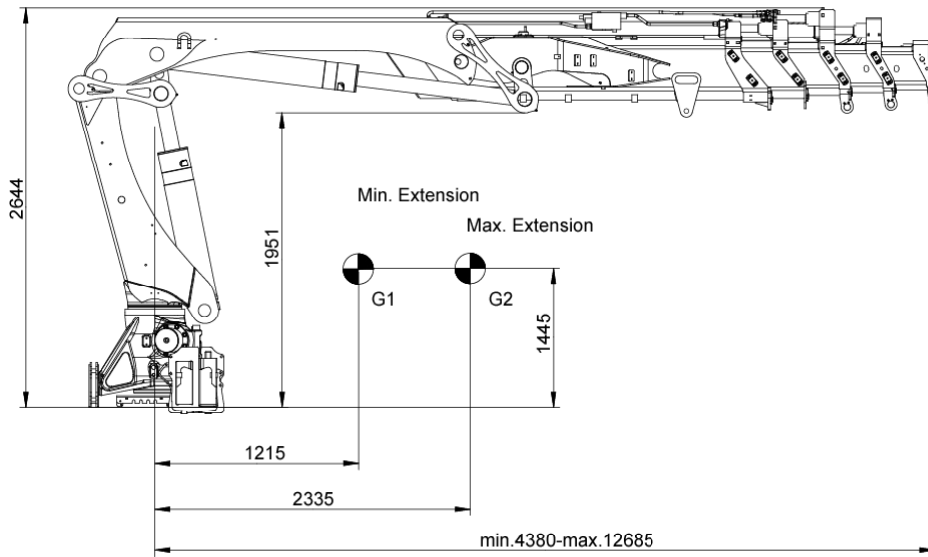

Side View Folded

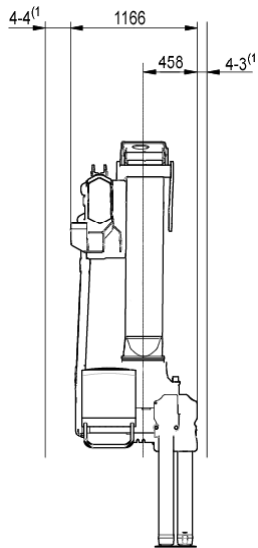

Front View Folded

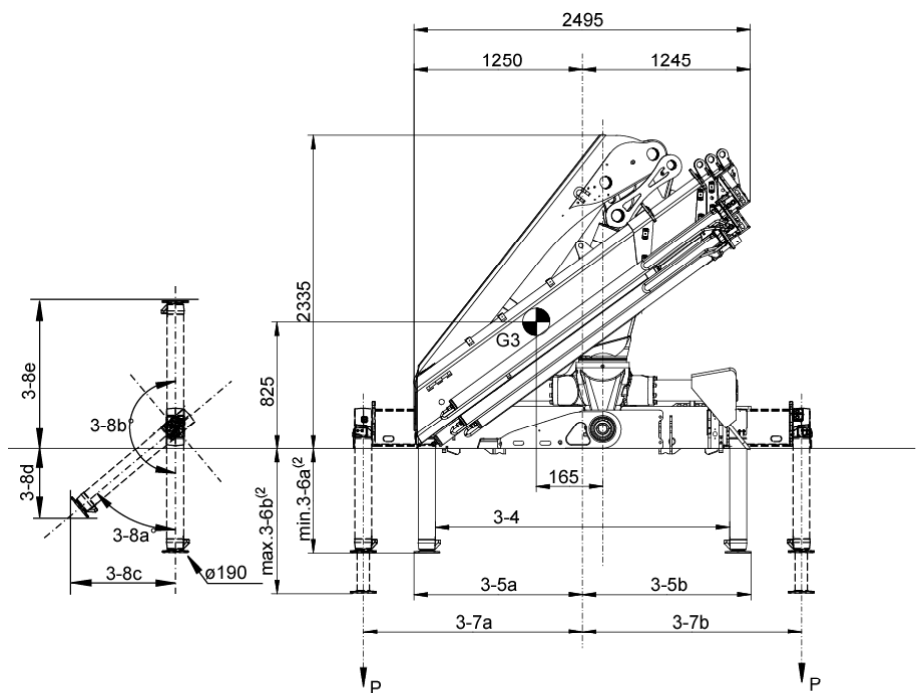

NOTE For specific values, see Table of Measurements

Top View Crane Base

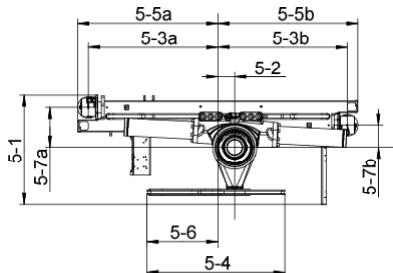

NOTE For specific values, see Table of Measurements

Chassis Installation

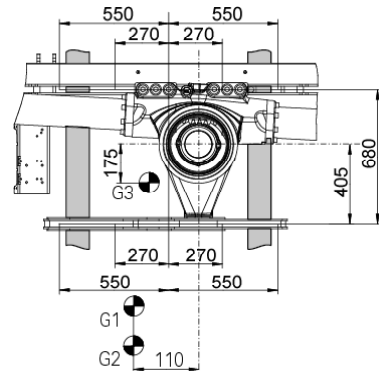

Load Diagram

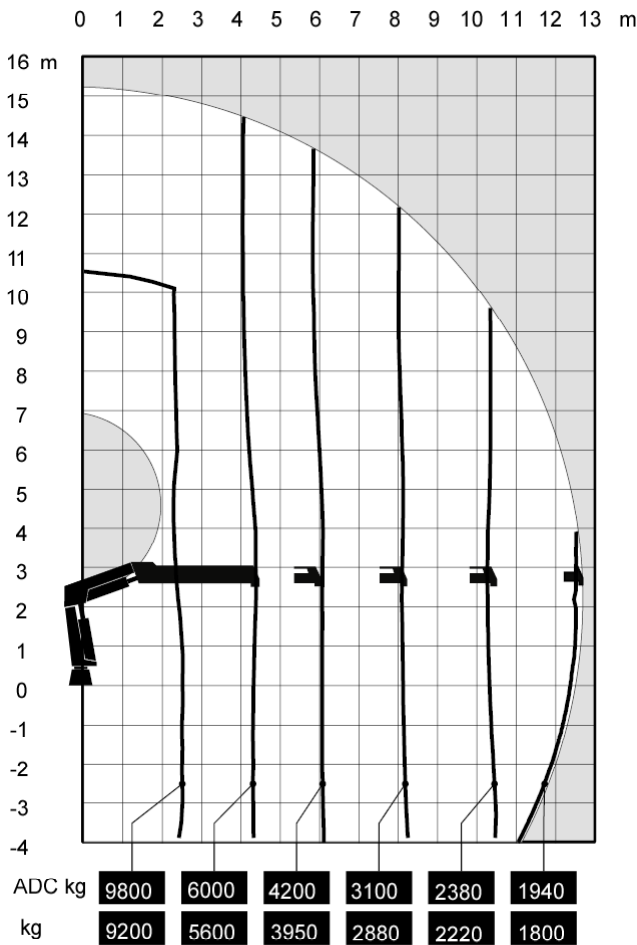

Capacity and performance

Lifting capacity with ADC	258.5 (kNm)
Lifting capacity	241.8 (kNm)
Standard lifting capacity at standard outreach with ADC	2.6 (m) - 9800 (kg) 4.4 (m) - 6000 (kg) 6.1 (m) - 4200 (kg) 8.1 (m) - 3100 (kg) 10.3 (m) - 2380 (kg) 12.6 (m) - 1940 (kg)
Standard lifting capacity at standard outreach	2.6 (m) - 9200 (kg) 4.4 (m) - 5600 (kg) 6.1 (m) - 3950 (kg) 8.1 (m) - 2880 (kg) 10.3 (m) - 2220 (kg) 12.6 (m) - 1800 (kg)
Manual lifting capacity at extension	15.0 (m) - 1540 (kg) 17.2 (m) - 1280 (kg)
Heavy lift capacity at heavy lift outreach	2.2 (m) - 11400 (kg)
Hydraulic boom extension	8.3 (m)
Manual max outreach	17.4 (m)
Lifting height above installation level hydraulic	15.3 (m)
Lifting height above installation level manual	19.8 (m)
Slewing torque	34 (kNm)
V80 Slewing speed	15 (°/s)
Slewing angle	420 (°)
Lifting speed	1.6 (m/s)

Functional demands

Recommended oil flow low	90 (l/min)
Recommended oil flow high	120 (l/min)
Working pressure	34 (MPa)
Max slope viable at full capacity	5 (°)

Weights and measurements

Height in folded position	2335 (mm)
Width in folded position	2495 (mm)
Installation space needed	1166 (mm)
Weight of crane	3070 (kg)
Weight support leg equipment	402 (kg)

Side View Unfolded Close in Area

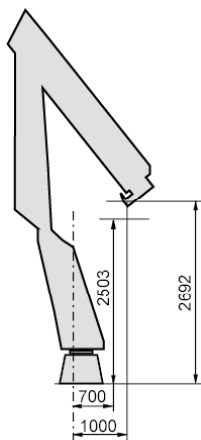

Side View Unfolded Stretched

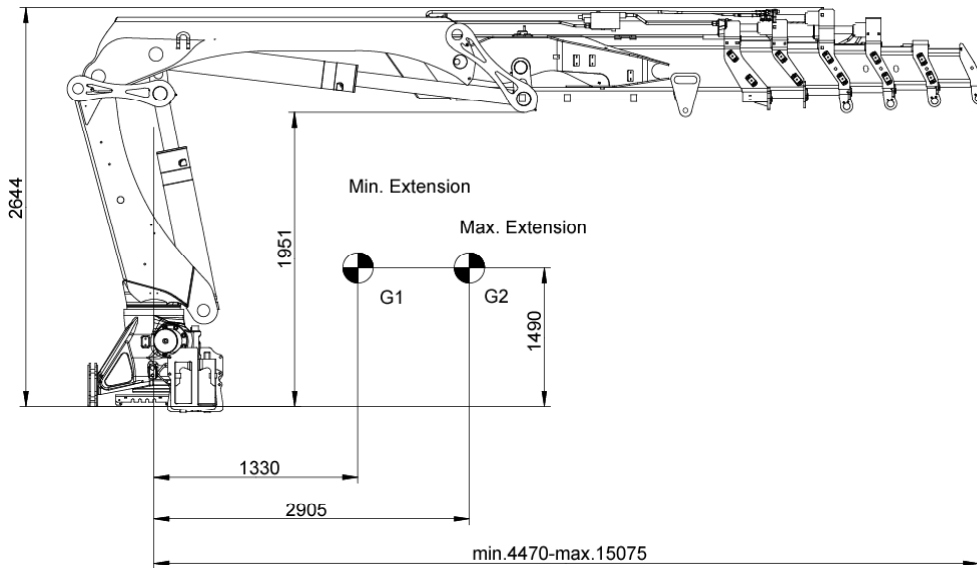

Side View Folded

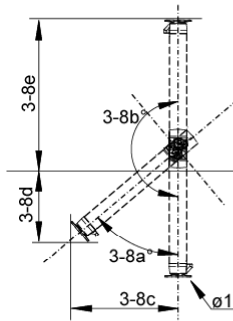
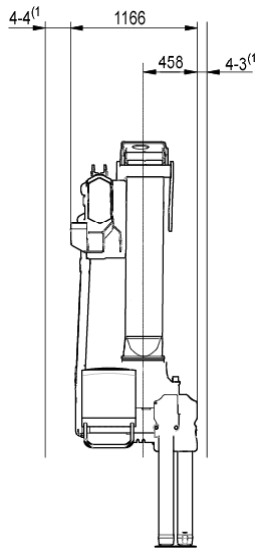

Front View Folded

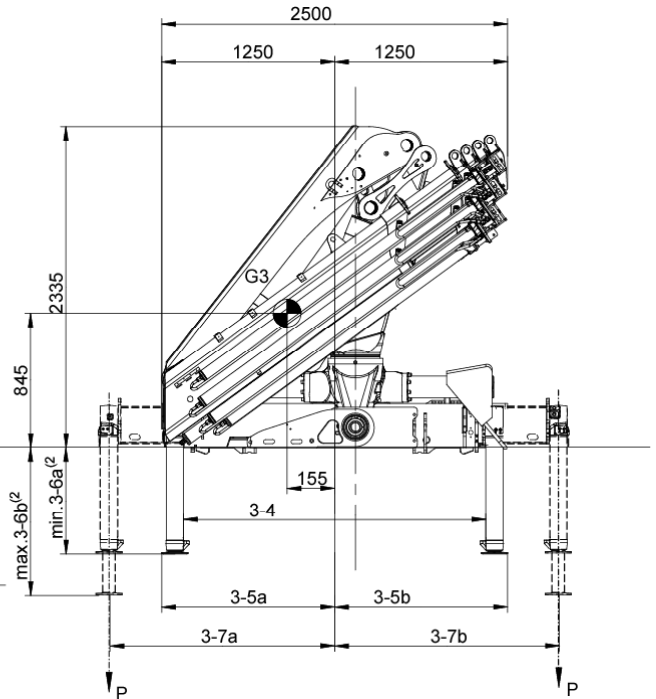

NOTE For specific values, see Table of Measurements

Top View Crane Base

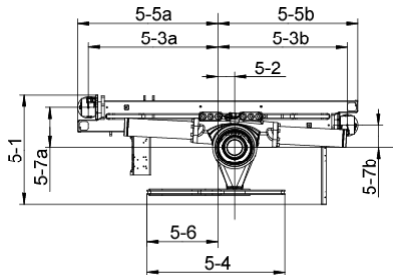

NOTE For specific values, see Table of Measurements

Chassis Installation

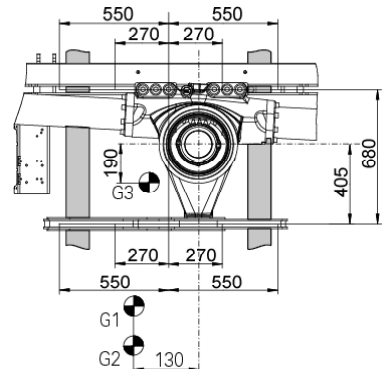

Load Diagram

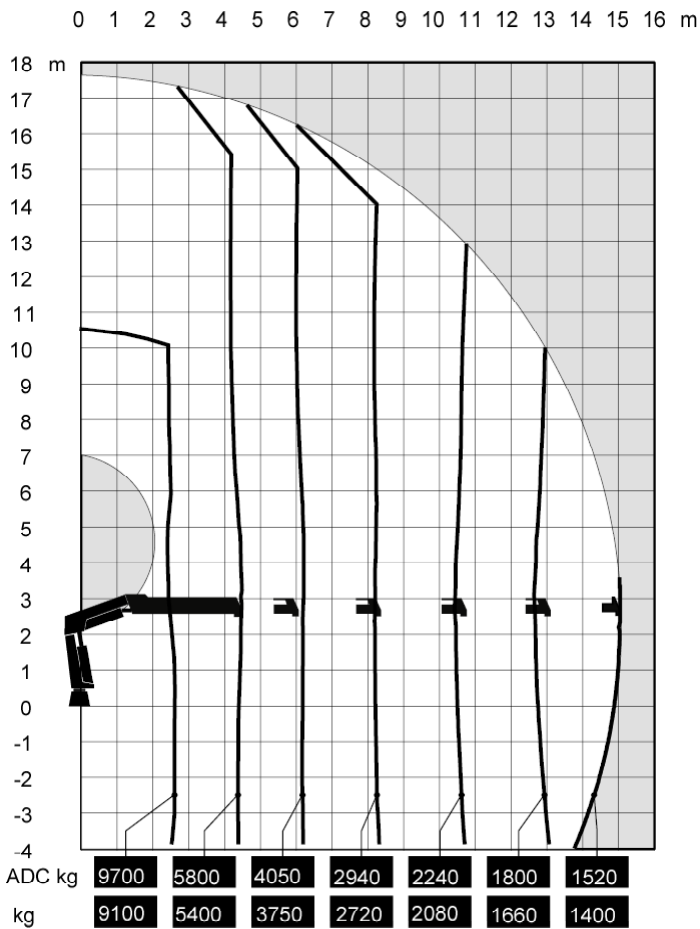

Capacity and performance

Lifting capacity with ADC	254.5 (kNm)
Lifting capacity	237.7 (kNm)
Standard lifting capacity at standard outreach with ADC	2.6 (m) - 9700 (kg) 4.5 (m) - 5800 (kg) 6.2 (m) - 4050 (kg) 8.2 (m) - 2940 (kg) 10.4 (m) - 2240 (kg) 12.7 (m) - 1800 (kg) 15.0 (m) - 1520 (kg)
Standard lifting capacity at standard outreach	2.6 (m) - 9100 (kg) 4.5 (m) - 5400 (kg) 6.2 (m) - 3750 (kg) 8.2 (m) - 2720 (kg) 10.4 (m) - 2080 (kg) 12.7 (m) - 1660 (kg) 15.0 (m) - 1400 (kg)
Manual lifting capacity at extension	17.2 (m) - 1260 (kg)
Heavy lift capacity at heavy lift outreach	2.2 (m) - 11300 (kg)
Hydraulic boom extension	10.6 (m)
Manual max outreach	17.4 (m)
Lifting height above installation level hydraulic	17.7 (m)
Lifting height above installation level manual	19.8 (m)
Slewing torque	34 (kNm)
V80 Slewing speed	15 (°/s)
Slewing angle	420 (°)
Lifting speed	1.9 m/s

Functional demands

Recommended oil flow low	90 (l/min)
Recommended oil flow high	120 (l/min)
Working pressure	34 (MPa)
Max slope viable at full capacity	5 (°)

Weights and measurements

Height in folded position	2335 (mm)
Width in folded position	2500 (mm)
Installation space needed	1166 (mm)
Weight of crane	3210 (kg)
Weight support leg equipment	402 (kg)

Side View Unfolded Close in Area

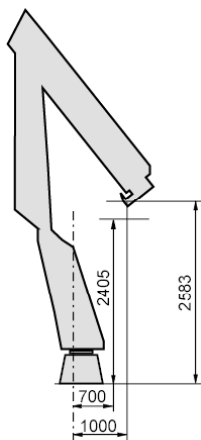

Side View Unfolded Stretched

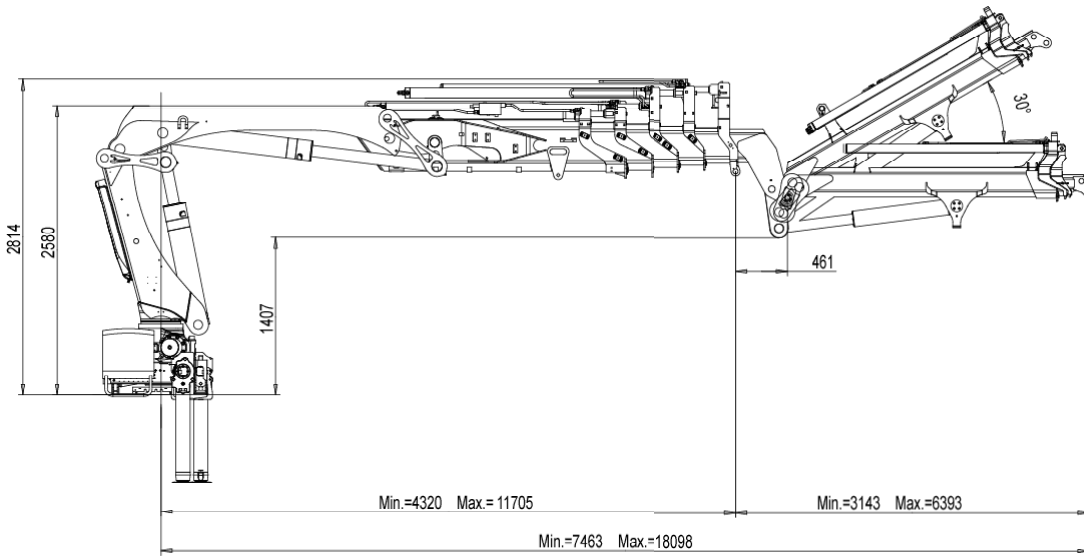

Side View Folded

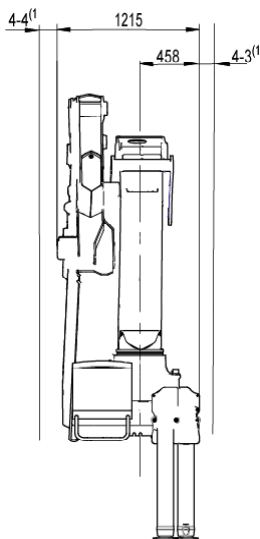

Front View Folded

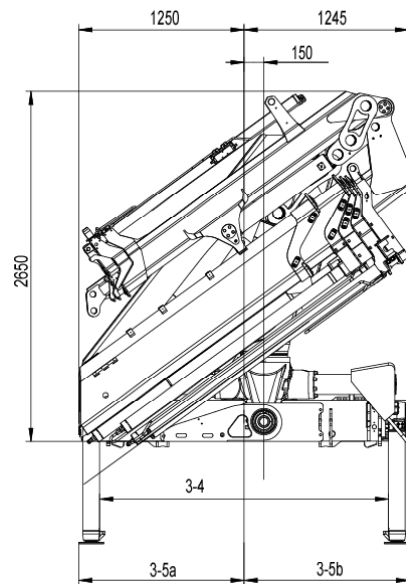

NOTE For specific values, see Table of Measurements

Top View Crane Base

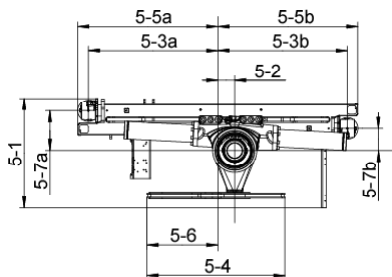

NOTE For specific values, see Table of Measurements

Chassis Installation

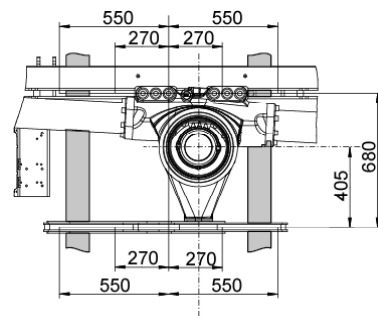

Load Diagram

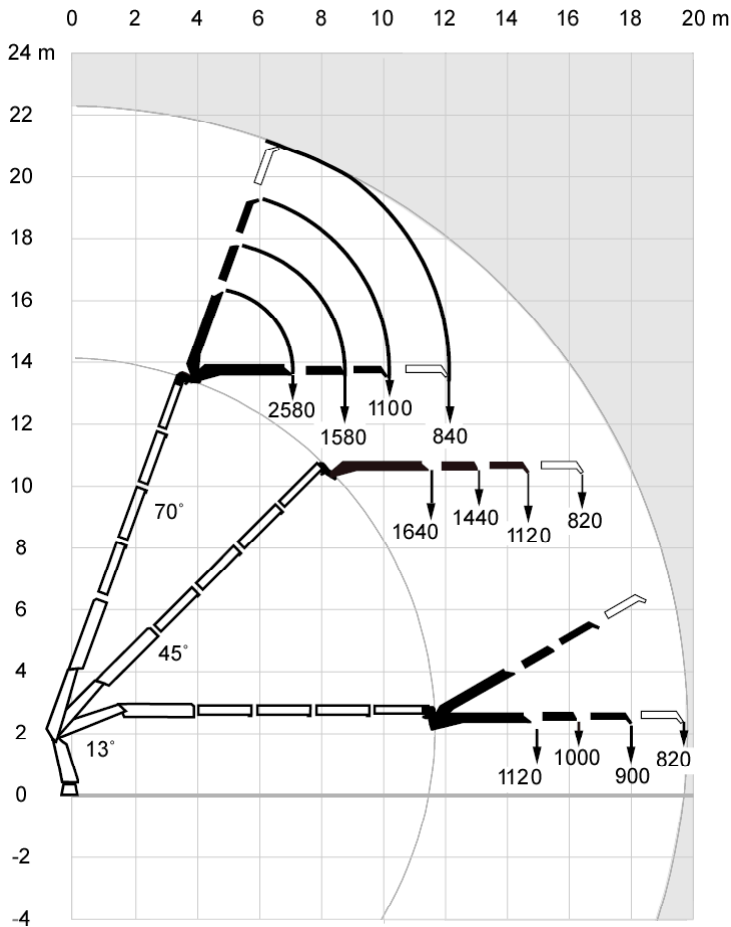

Capacity and performance

Lifting capacity with ADC	256.4 (kNm)
Lifting capacity	239.7 (kNm)
Standard lifting capacity at standard outreach with ADC	2.6 (m) - 9800 (kg)
	4.3 (m) - 6100 (kg)
	5.9 (m) - 4300 (kg)
	7.7 (m) - 3250 (kg)
	9.6 (m) - 2540 (kg)
Standard lifting capacity at standard outreach	11.6 (m) - 2080 (kg)
	2.6 (m) - 9200 (kg)
	4.3 (m) - 5700 (kg)
	5.9 (m) - 4050 (kg)
	7.7 (m) - 3000 (kg)
Manual lifting capacity at extension	9.6 (m) - 2360 (kg)
	11.6 (m) - 1940 (kg)
	13.7 (m) - 1700 (kg)
Heavy lift capacity at heavy lift outreach	15.9 (m) - 1400 (kg)
	2.2 (m) - 11300 (kg)
Hydraulic boom extension	7.4 (m)
Manual max outreach	18.6 (m)
Lifting height above installation level hydraulic	14.3 (m)
Lifting height above installation level manual	18.5 (m)
Slewing torque	34 (kNm)
V80 Slewing speed	15 (°/s)
Slewing angle	420 (°)
Lifting speed	1.5 (m/s)
Jib hydraulic outreach	18.1 (m)
Jib manual outreach	19.9 (m)
Jib standard lifting capacity at standard extension	14.8 (m) - 1120 (kg)
	16.3 (m) - 1000 (kg)
	18.0 (m) - 900 (kg)
Jib manual lifting capacity at manual extension	19.8 (m) - 820 (kg)

Side View Unfolded Close in Area

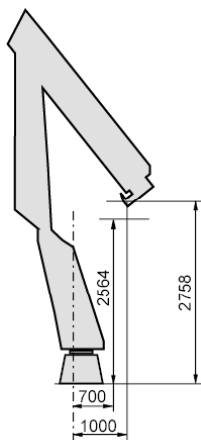

Functional demands

Recommended oil flow low	90 (l/min)
Recommended oil flow high	120 (l/min)
Working pressure	34 (MPa)
Max slope viable at full capacity	5 (°)

Weights and measurements

Height in folded position	2650 (mm)
Width in folded position	2500 (mm)
Installation space needed	1215 (mm)
Weight of crane	3700 (kg)
Weight support leg equipment	402 (kg)
Weight of crane with Jib	3700 (kg)

Side View Unfolded Stretched

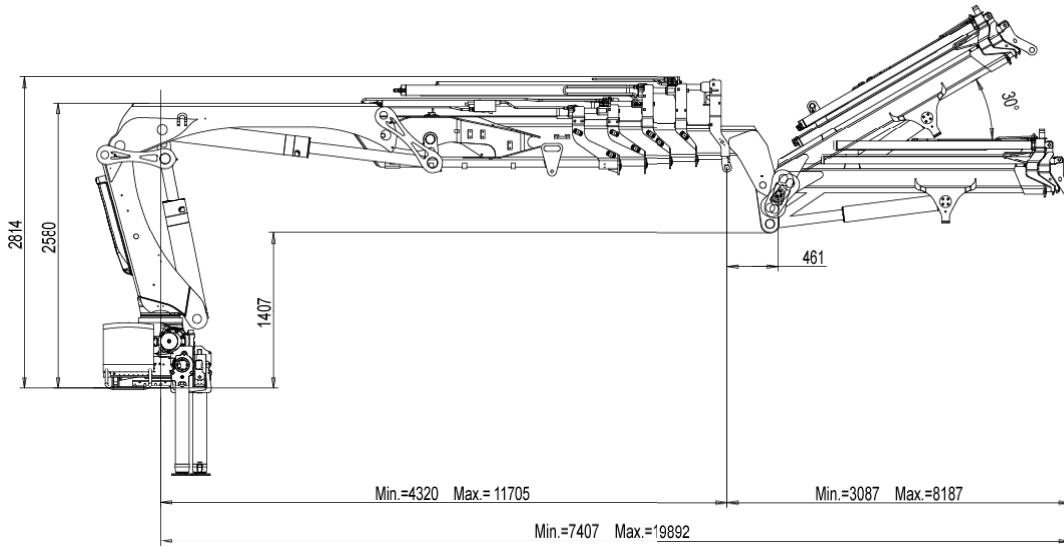

Side View Folded

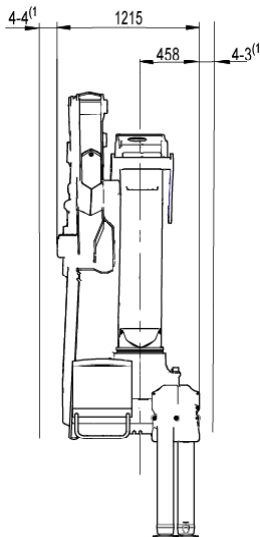

Front View Folded

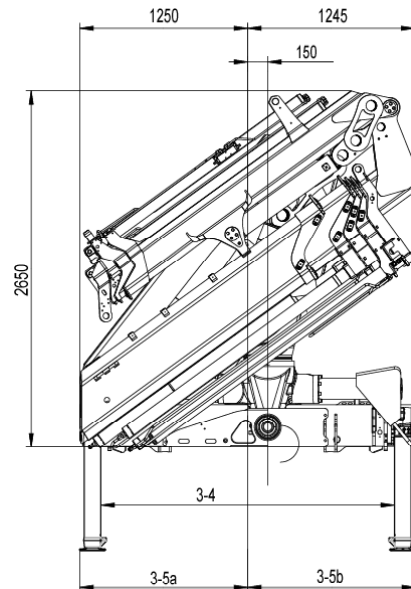

NOTE For specific values, see Table of Measurements

Top View Crane Base

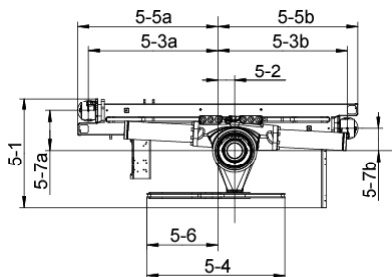

NOTE For specific values, see Table of Measurements

Chassis Installation

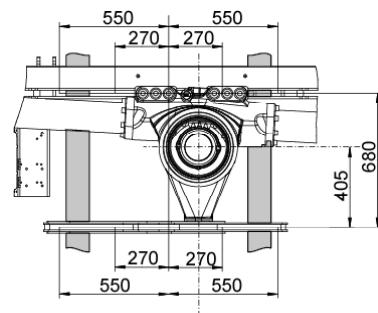

Load Diagram

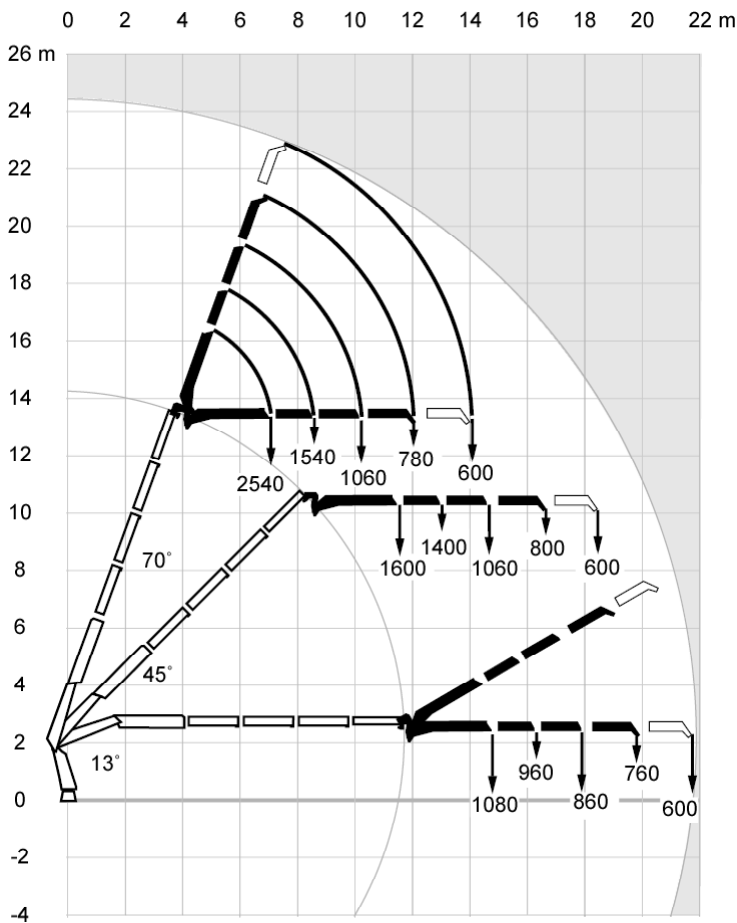

Capacity and performance

Lifting capacity with ADC	256.4 (kNm)
Lifting capacity	239.7 (kNm)
Standard lifting capacity at standard outreach with ADC	2.6 (m) - 9800 (kg) 4.3 (m) - 6100 (kg) 5.9 (m) - 4300 (kg) 7.7 (m) - 3250 (kg) 9.6 (m) - 2540 (kg) 11.6 (m) - 2080 (kg)
Standard lifting capacity at standard outreach	2.6 (m) - 9200 (kg) 4.3 (m) - 5700 (kg) 5.9 (m) - 4050 (kg) 7.7 (m) - 3000 (kg) 9.6 (m) - 2360 (kg) 11.6 (m) - 1940 (kg)
Manual lifting capacity at extension	13.7 (m) - 1700 (kg) 15.9 (m) - 1400 (kg)
Heavy lift capacity at heavy lift outreach	2.2 (m) - 11300 (kg)
Hydraulic boom extension	7.4 (m)
Manual max outreach	18.6 (m)
Lifting height above installation level hydraulic	14.3 (m)
Lifting height above installation level manual	18.5 (m)
Slewing torque	34 (kNm)
V80 Slewing speed	15 (°/s)
Slewing angle	420 (°)
Lifting speed	1.5 (m/s)
Jib hydraulic outreach	19.9 (m)
Jib manual outreach	21.9 (m)
Jib standard lifting capacity at standard extension	14.8 (m) - 1080 (kg) 16.3 (m) - 960 (kg) 17.9 (m) - 860 (kg) 19.8 (m) - 760 (kg)
Jib manual lifting capacity at manual extension	21.8 (m) - 600 (kg)

Side View Unfolded Close in Area

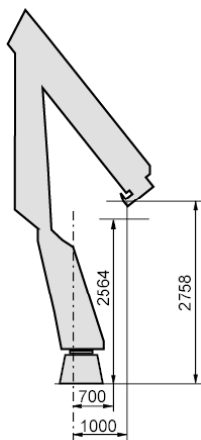

Functional demands

Recommended oil flow low	90 (l/min)
Recommended oil flow high	120 (l/min)
Working pressure	34 (MPa)
Max slope viable at full capacity	5 (°)

Weights and measurements

Height in folded position	2650 (mm)
Width in folded position	2500 (mm)
Installation space needed	1215 (mm)
Weight of crane	3780 (kg)
Weight support leg equipment	402 (kg)
Weight of crane with Jib	3780 (kg)

Side View Unfolded Stretched

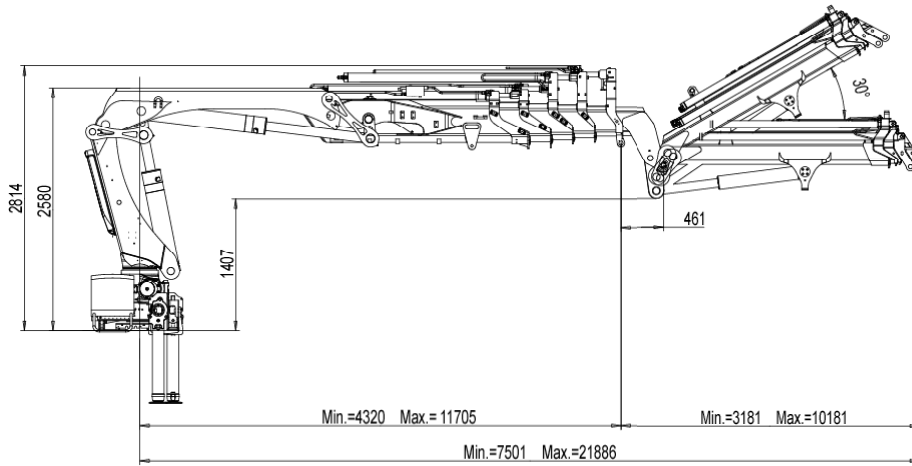

Side View Folded

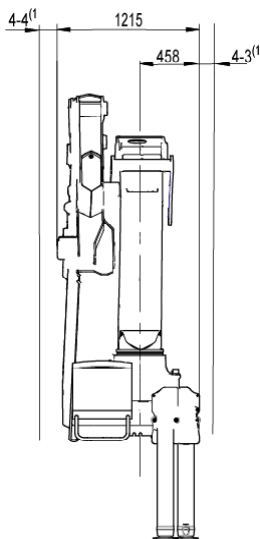

Front View Folded

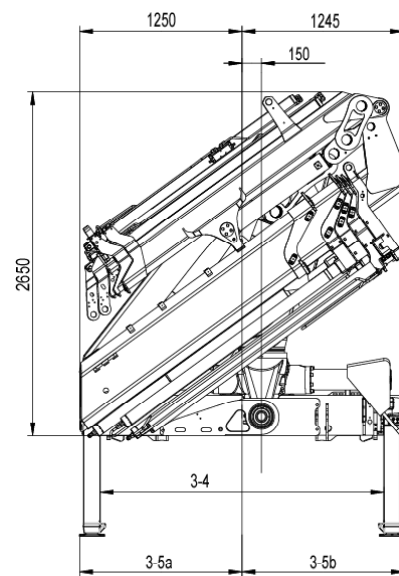

NOTE For specific values, see Table of Measurements

Top View Crane Base

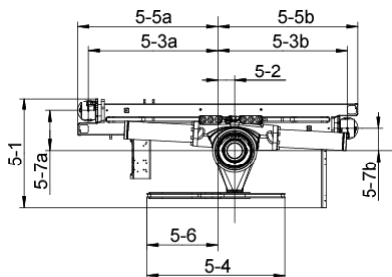

NOTE For specific values, see Table of Measurements

Chassis Installation

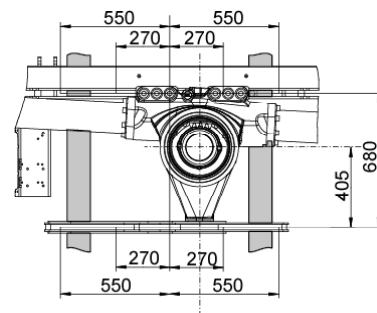

Load Diagram

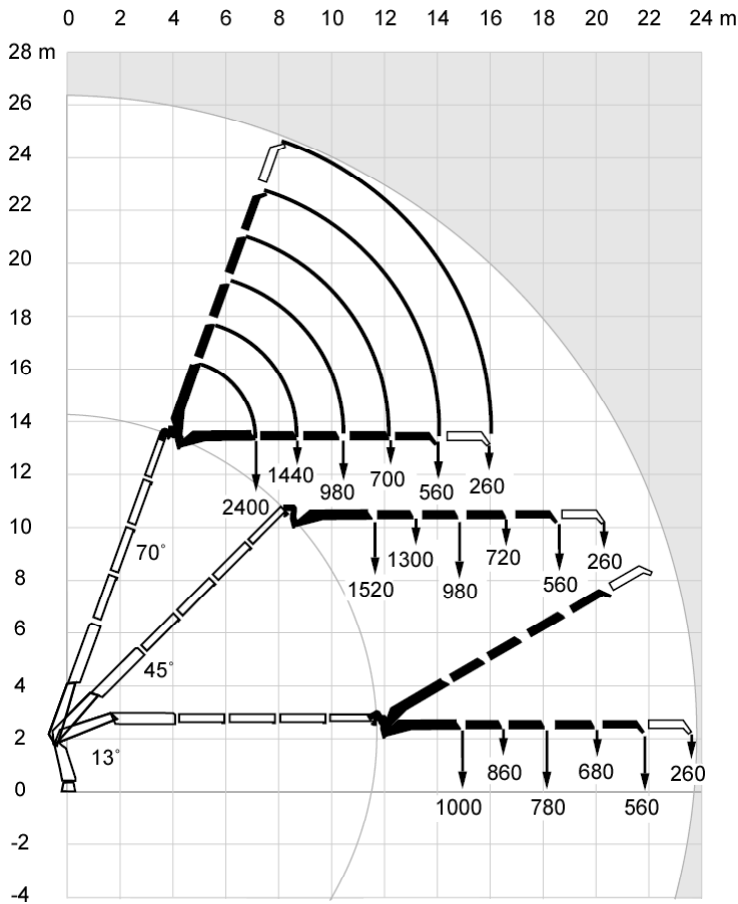

Capacity and performance

Lifting capacity with ADC	256.4 (kNm)
Lifting capacity	239.7 (kNm)
Standard lifting capacity at standard outreach with ADC	2.6 (m) - 9800 (kg)
	4.3 (m) - 6100 (kg)
	5.9 (m) - 4300 (kg)
	7.7 (m) - 3250 (kg)
	9.6 (m) - 2540 (kg)
Standard lifting capacity at standard outreach	11.6 (m) - 2080 (kg)
	2.6 (m) - 9200 (kg)
	4.3 (m) - 5700 (kg)
	5.9 (m) - 4050 (kg)
	7.7 (m) - 3000 (kg)
Manual lifting capacity at extension	9.6 (m) - 2360 (kg)
	11.6 (m) - 1940 (kg)
	13.7 (m) - 1700 (kg)
Heavy lift capacity at heavy lift outreach	15.9 (m) - 1400 (kg)
	2.2 (m) - 11300 (kg)
Hydraulic boom extension	7.4 (m)
Manual max outreach	18.6 (m)
Lifting height above installation level hydraulic	14.3 (m)
Lifting height above installation level manual	18.5 (m)
Slewing torque	34 (kNm)
V80 Slewing speed	15 (°/s)
Slewing angle	420 (°)
Lifting speed	1.5 (m/s)
Jib hydraulic outreach	21.9 (m)
Jib manual outreach	23.8 (m)
Jib standard lifting capacity at standard extension	14.9 (m) - 980 (kg)
	16.4 (m) - 860 (kg)
	18.0 (m) - 760 (kg)
	19.9 (m) - 660 (kg)
	21.8 (m) - 560 (kg)
Jib manual lifting capacity at manual extension	23.7 (m) - 260 (kg)

Side View Unfolded Close in Area

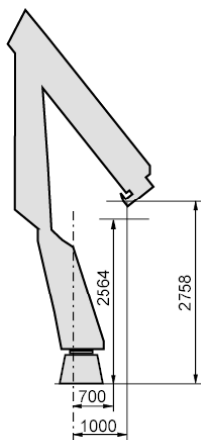

Functional demands

Recommended oil flow low	90 (l/min)
Recommended oil flow high	120 (l/min)
Working pressure	34 (MPa)
Max slope viable at full capacity	5 (°)

Weights and measurements

Height in folded position	2650 (mm)
Width in folded position	2500 (mm)
Installation space needed	1215 (mm)
Weight of crane	3860 (kg)
Weight support leg equipment	402 (kg)
Weight of crane with Jib	3860 (kg)

Side View Unfolded Stretched

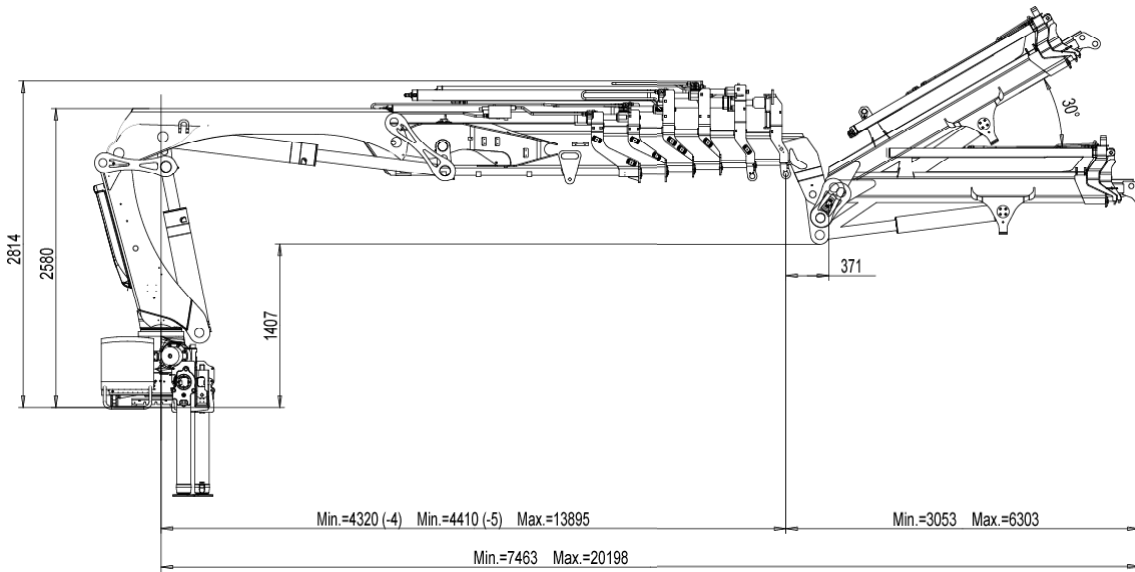

Side View Folded

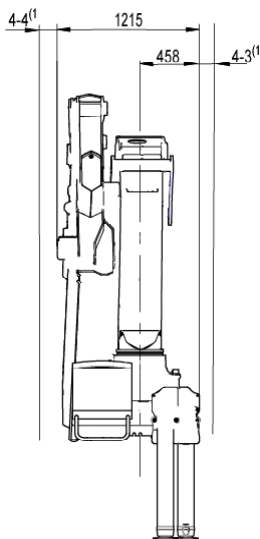

Front View Folded

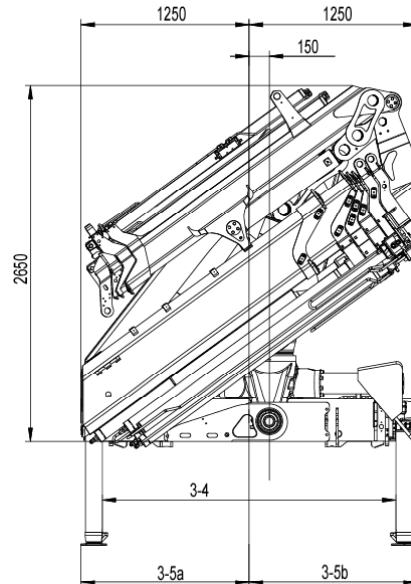

NOTE For specific values, see Table of Measurements

Top View Crane Base

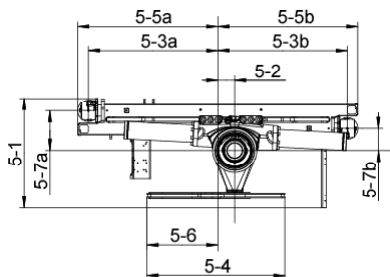

NOTE For specific values, see Table of Measurements

Chassis Installation

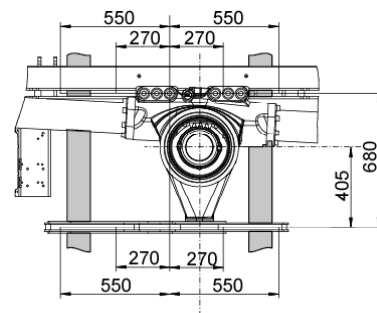

Load Diagram

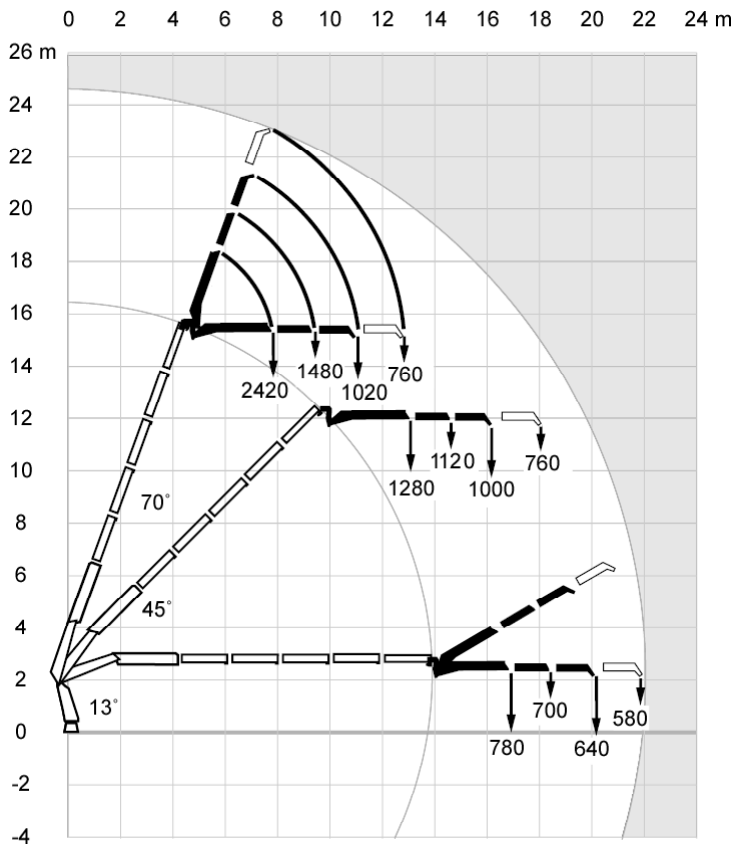

Capacity and performance

Lifting capacity with ADC	250.8 (kNm)
Lifting capacity	234 (kNm)
Standard lifting capacity at standard outreach with ADC	2.6 (m) - 9600 (kg)
	4.4 (m) - 5800 (kg)
	6.0 (m) - 4100 (kg)
	7.8 (m) - 3050 (kg)
	9.7 (m) - 2360 (kg)
	11.7 (m) - 1900 (kg)
	13.8 (m) - 1600 (kg)
Standard lifting capacity at standard outreach	2.6 (m) - 9000 (kg)
	4.4 (m) - 5400 (kg)
	6.0 (m) - 3800 (kg)
	7.8 (m) - 2800 (kg)
	9.7 (m) - 2160 (kg)
	11.7 (m) - 1740 (kg)
	13.8 (m) - 1460 (kg)
Manual lifting capacity at extension	15.8 (m) - 1320 (kg)
	17.5 (m) - 1140 (kg)
Heavy lift capacity at heavy lift outreach	2.2 (m) - 11100 (kg)
Hydraulic boom extension	9.5 (m)
Manual max outreach	21.0 (m)
Lifting height above installation level hydraulic	16.5 (m)
Lifting height above installation level manual	20.1 (m)
Slewing torque	34 (kNm)
V80 Slewing speed	15 (°/s)
Slewing angle	420 (°)
Lifting speed	1.8 (m/s)
Jib hydraulic outreach	20.2 (m)
Jib manual outreach	22.0 (m)
Jib standard lifting capacity at standard extension	16.9 (m) - 780 (kg)
	18.4 (m) - 700 (kg)
	20.1 (m) - 640 (kg)
Jib manual lifting capacity at manual extension	21.9 (m) - 580 (kg)

Side View Unfolded Close in Area

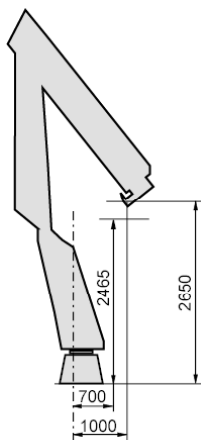

Functional demands

Recommended oil flow low	90 (l/min)
Recommended oil flow high	120 (l/min)
Working pressure	34 (MPa)
Max slope viable at full capacity	5 (°)

Weights and measurements

Height in folded position	2650 (mm)
Width in folded position	2500 (mm)
Installation space needed	1215 (mm)
Weight of crane	3895 (kg)
Weight support leg equipment	402 (kg)
Weight of crane with Jib	3895 (kg)

Side View Unfolded Stretched

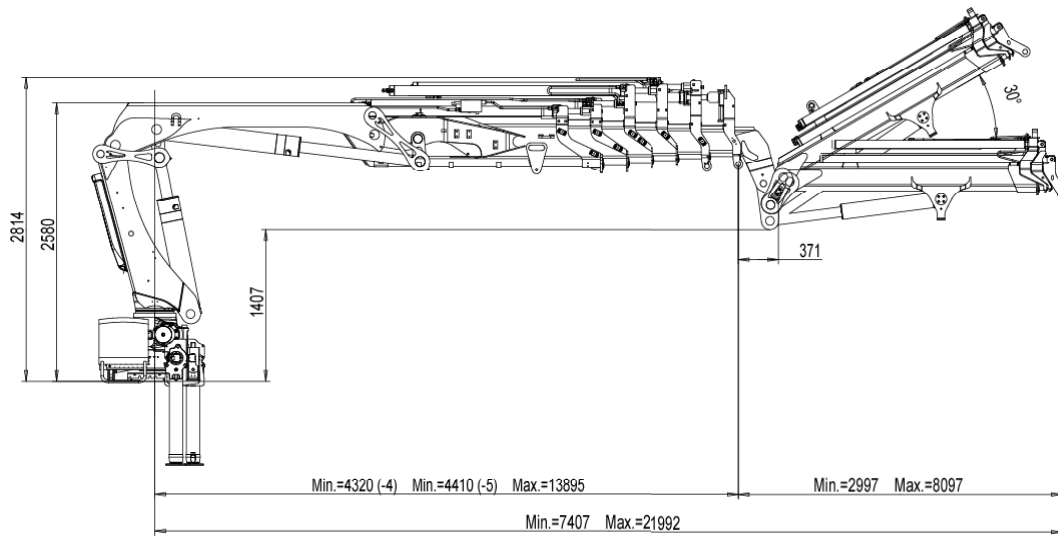

Side View Folded

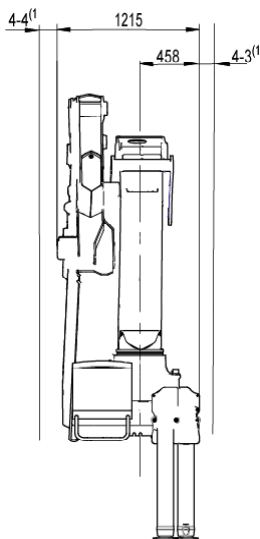

Front View Folded

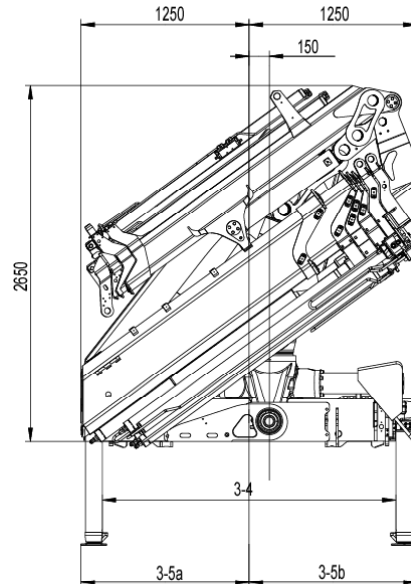

NOTE For specific values, see Table of Measurements

Top View Crane Base

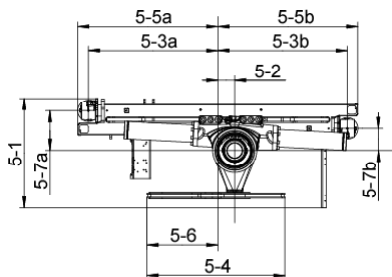

NOTE For specific values, see Table of Measurements

Chassis Installation

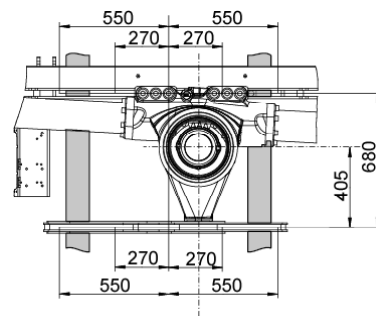

Load Diagram

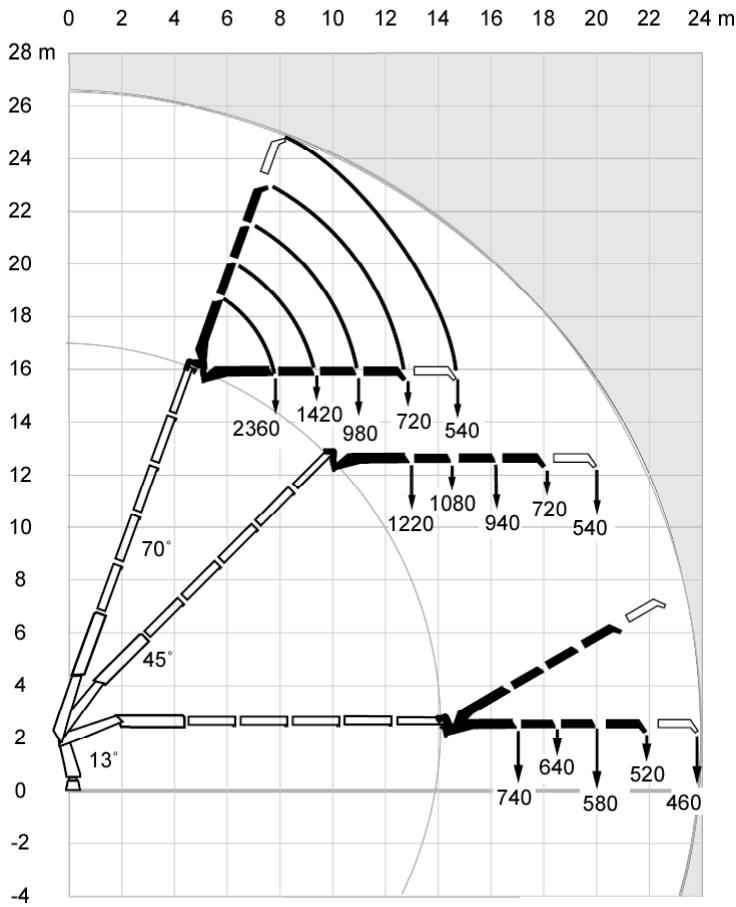

Capacity and performance

Lifting capacity with ADC	250.8 (kNm)
Lifting capacity	234 (kNm)
Standard lifting capacity at standard outreach with ADC	2.6 (m) - 9600 (kg) 4.4 (m) - 5800 (kg) 6.0 (m) - 4100 (kg) 7.8 (m) - 3050 (kg) 9.7 (m) - 2360 (kg) 11.7 (m) - 1900 (kg) 13.8 (m) - 1600 (kg)
Standard lifting capacity at standard outreach	2.6 (m) - 9000 (kg) 4.4 (m) - 5400 (kg) 6.0 (m) - 3800 (kg) 7.8 (m) - 2800 (kg) 9.7 (m) - 2160 (kg) 11.7 (m) - 1740 (kg) 13.8 (m) - 1460 (kg)
Manual lifting capacity at extension	15.8 (m) - 1320 (kg) 17.5 (m) - 1140 (kg)
Heavy lift capacity at heavy lift outreach	2.2 (m) - 11100 (kg)
Hydraulic boom extension	9.5 (m)
Manual max outreach	21.0 (m)
Lifting height above installation level hydraulic	16.5 (m)
Lifting height above installation level manual	20.1 (m)
Slewing torque	34 (kNm)
V80 Slewing speed	15 (°/s)
Slewing angle	420 (°)
Lifting speed	1.8 (m/s)
Jib hydraulic outreach	22.0 (m)
Jib manual outreach	24.0 (m)
Jib standard lifting capacity at standard extension	16.9 (m) - 740 (kg) 18.4 (m) - 640 (kg) 20.0 (m) - 580 (kg) 21.9 (m) - 520 (kg)
Jib manual lifting capacity at manual extension	23.9 (m) - 460 (kg)

Side View Unfolded Close in Area

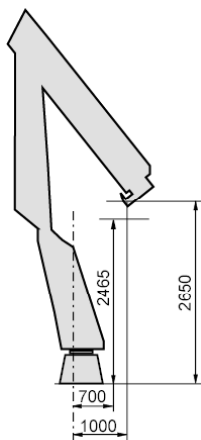

Functional demands

Recommended oil flow low	90 (l/min)
Recommended oil flow high	120 (l/min)
Working pressure	34 (MPa)
Max slope viable at full capacity	5 (°)

Weights and measurements

Height in folded position	2650 (mm)
Width in folded position	2500 (mm)
Installation space needed	1215 (mm)
Weight of crane	3975 (kg)
Weight support leg equipment	402 (kg)
Weight of crane with Jib	3975 (kg)

Side View Unfolded Stretched

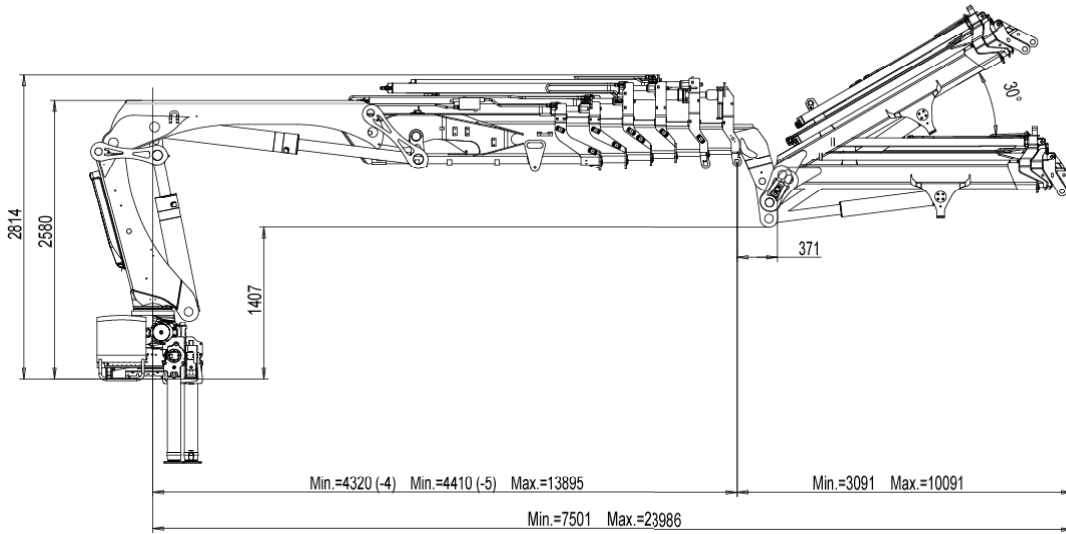

Side View Folded

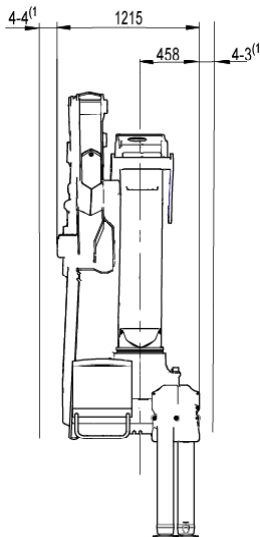

Front View Folded

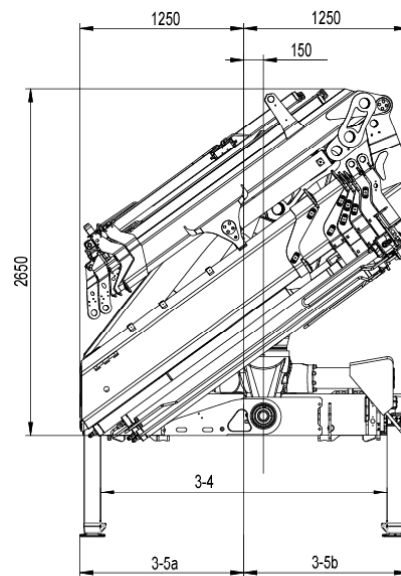

NOTE For specific values, see Table of Measurements

Top View Crane Base

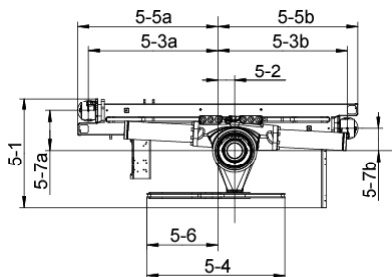

NOTE For specific values, see Table of Measurements

Chassis Installation

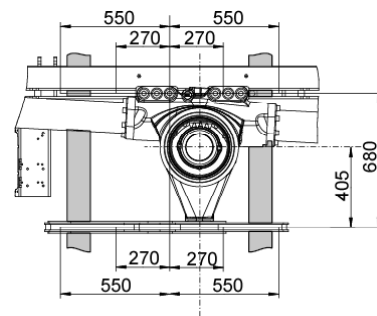

Load Diagram

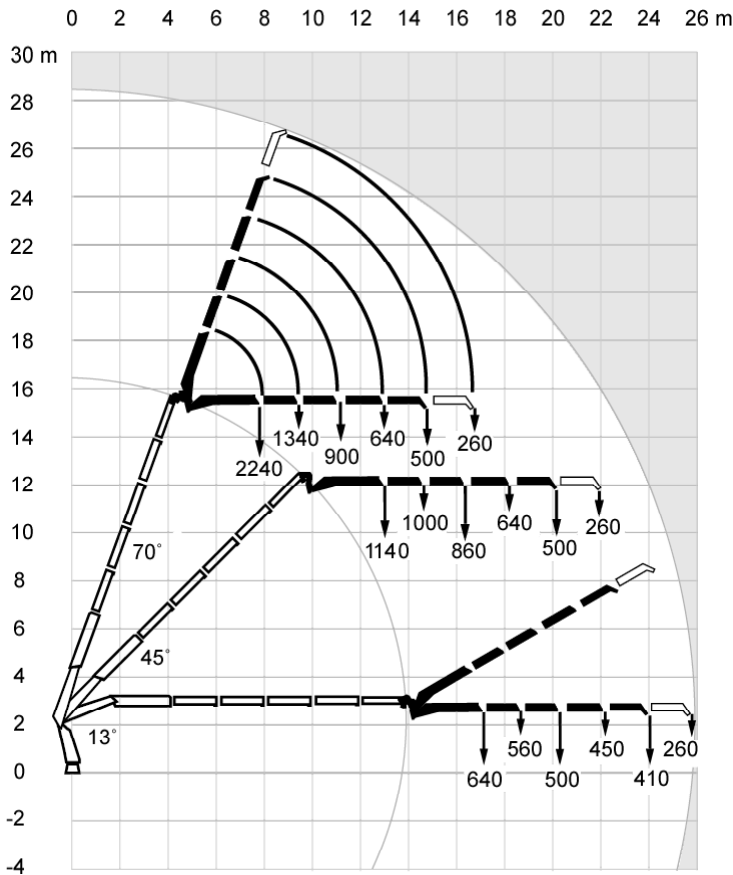

Capacity and performance

Lifting capacity with ADC	250.8 (kNm)
Lifting capacity	234 (kNm)
Standard lifting capacity at standard outreach with ADC	2.6 (m) - 9600 (kg) 4.4 (m) - 5800 (kg) 6.0 (m) - 4100 (kg) 7.8 (m) - 3050 (kg) 9.7 (m) - 2360 (kg) 11.7 (m) - 1900 (kg) 13.8 (m) - 1600 (kg)
Standard lifting capacity at standard outreach	2.6 (m) - 9000 (kg) 4.4 (m) - 5400 (kg) 6.0 (m) - 3800 (kg) 7.8 (m) - 2800 (kg) 9.7 (m) - 2160 (kg) 11.7 (m) - 1740 (kg) 13.8 (m) - 1460 (kg)
Manual lifting capacity at extension	15.8 (m) - 1320 (kg) 17.5 (m) - 1140 (kg)
Heavy lift capacity at heavy lift outreach	2.2 (m) - 11100 (kg)
Hydraulic boom extension	9.5 (m)
Manual max outreach	21.0 (m)
Lifting height above installation level hydraulic	16.5 (m)
Lifting height above installation level manual	20.1 (m)
Slewing torque	34 (kNm)
V80 Slewing speed	15 (°/s)
Slewing angle	420 (°)
Lifting speed	1.8 (m/s)
Jib hydraulic outreach	24.0 (m)
Jib manual outreach	25.9 (m)
Jib standard lifting capacity at standard extension	17.0 (m) - 640 (kg) 18.5 (m) - 540 (kg) 20.1 (m) - 480 (kg) 22.0 (m) - 430 (kg) 23.9 (m) - 390 (kg)
Jib manual lifting capacity at manual extension	25.8 (m) - 260 (kg)

Side View Unfolded Close in Area

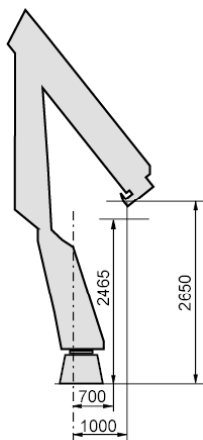

Functional demands

Recommended oil flow low	90 (l/min)
Recommended oil flow high	120 (l/min)
Working pressure	34 (MPa)
Max slope viable at full capacity	5 (°)

Weights and measurements

Height in folded position	2650 (mm)
Width in folded position	2500 (mm)
Installation space needed	1215 (mm)
Weight of crane	4055 (kg)
Weight support leg equipment	402 (kg)
Weight of crane with Jib	4055 (kg)

Side View Unfolded Stretched

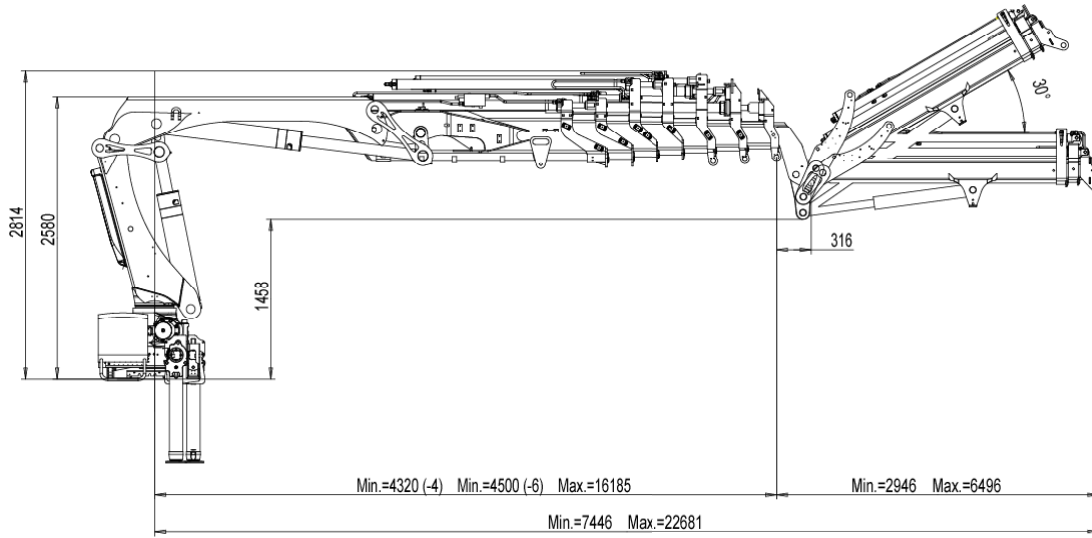

Side View Folded

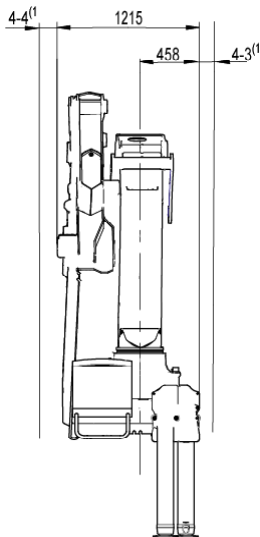

Front View Folded

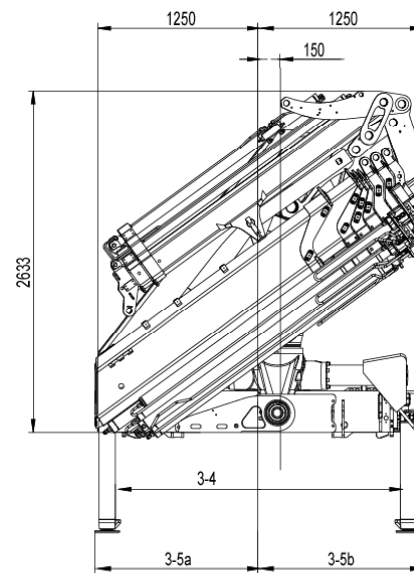

NOTE For specific values, see Table of Measurements

Top View Crane Base

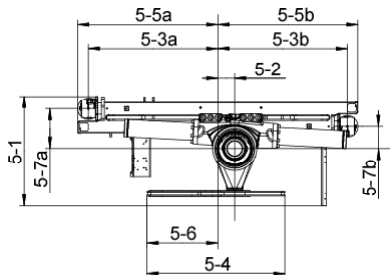

NOTE For specific values, see Table of Measurements

Chassis Installation

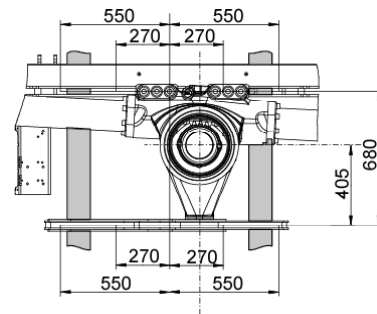

Load Diagram

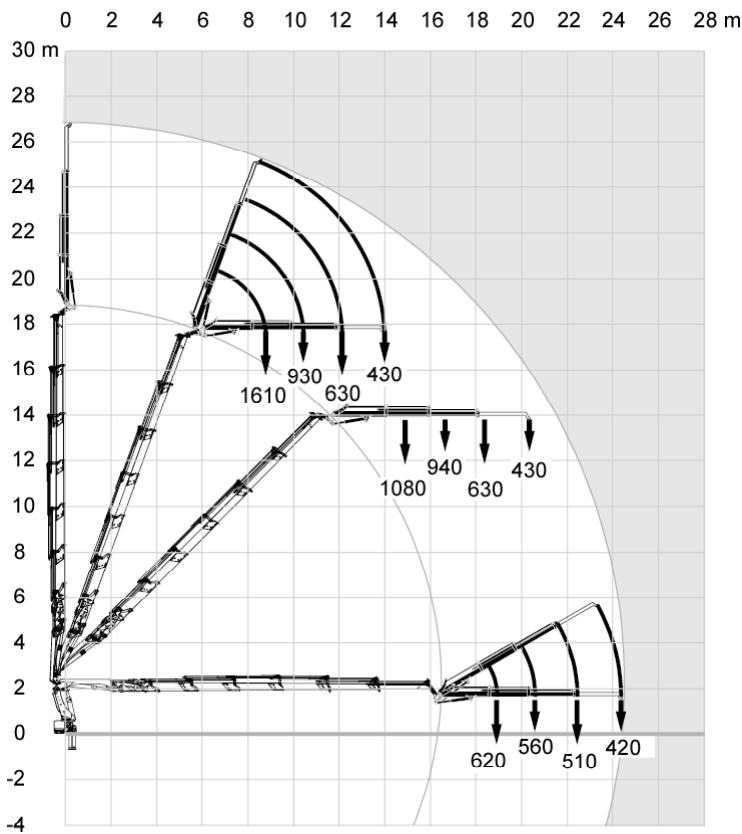

Side View Unfolded Close in Area

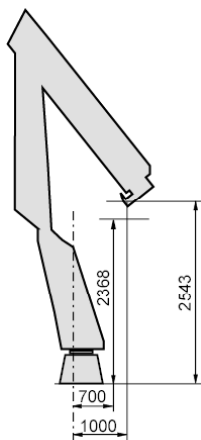

Capacity and performance

Lifting capacity with ADC	245.3 (kNm)
Lifting capacity	228.5 (kNm)
Standard lifting capacity at standard outreach with ADC	2.6 (m) - 9400 (kg)
	4.5 (m) - 5500 (kg)
	6.1 (m) - 3900 (kg)
	7.9 (m) - 2840 (kg)
	9.8 (m) - 2180 (kg)
	11.8 (m) - 1740 (kg)
	13.9 (m) - 1420 (kg)
	16.1 (m) - 1220 (kg)
Standard lifting capacity at standard outreach	2.6 (m) - 8800 (kg)
	4.5 (m) - 5200 (kg)
	6.1 (m) - 3600 (kg)
	7.9 (m) - 2620 (kg)
	9.8 (m) - 2000 (kg)
	11.8 (m) - 1580 (kg)
	13.9 (m) - 1300 (kg)
	16.1 (m) - 1100 (kg)
Manual lifting capacity at extension	18.3 (m) - 980 (kg)
	20.4 (m) - 840 (kg)
Heavy lift capacity at heavy lift outreach	2.2 (m) - 10900 (kg)
Hydraulic boom extension	11.7 (m)
Manual max outreach	23.3 (m)
Lifting height above installation level hydraulic	18.8 (m)
Lifting height above installation level manual	23.1 (m)
Slewing torque	34 (kNm)
V80 Slewing speed	15 (°/s)
Slewing angle	420 (°)
Lifting speed	2.1 m/s
Jib hydraulic outreach	22.7 (m)
Jib manual outreach	24.7 (m)
Jib standard lifting capacity at standard extension	19.1 (m) - 620 (kg)
	20.7 (m) - 560 (kg)
	22.6 (m) - 510 (kg)
Jib manual lifting capacity at manual extension	24.6 (m) - 420 (kg)
Functional demands	
Recommended oil flow low	90 (l/min)
Recommended oil flow high	120 (l/min)
Working pressure	34 (MPa)
Max slope viable at full capacity	5 (°)
Weights and measurements	
Height in folded position	2633 (mm)
Width in folded position	2500 (mm)
Installation space needed	1215 (mm)
Weight of crane	3950 (kg)
Weight support leg equipment	402 (kg)
Weight of crane with Jib	3950 (kg)

Side View Unfolded Stretched

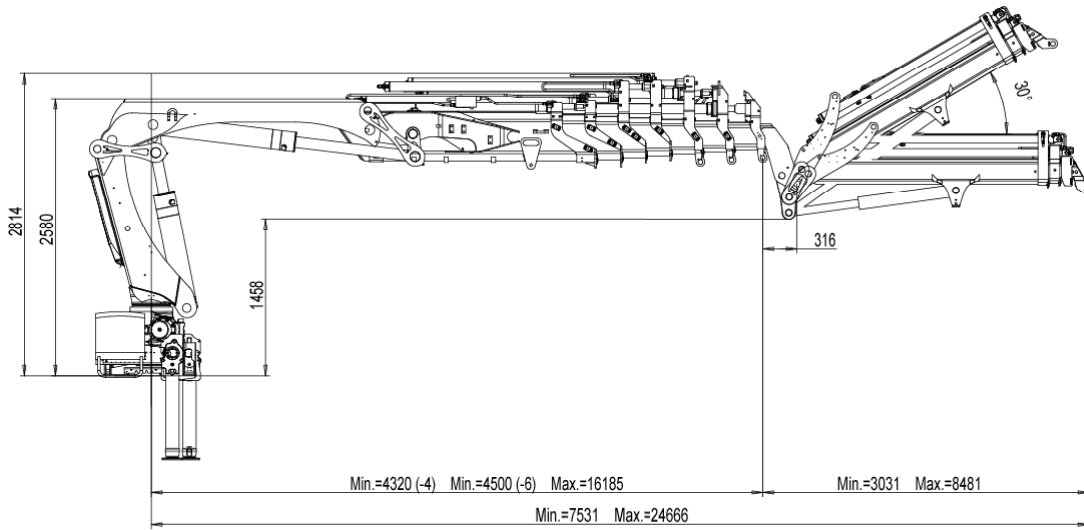

Side View Folded

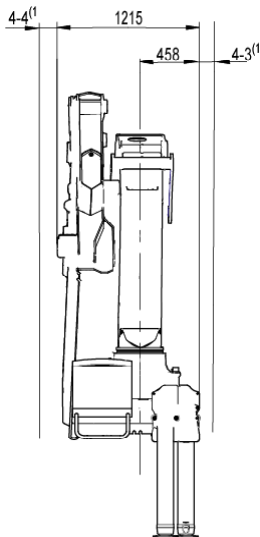

Front View Folded

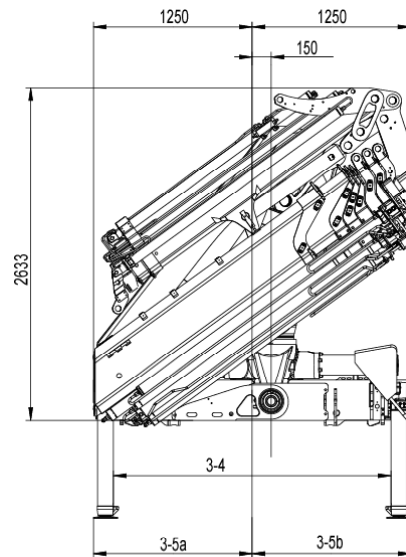

NOTE For specific values, see Table of Measurements

Top View Crane Base

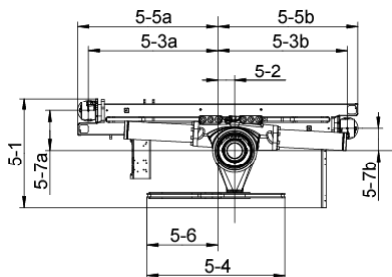

NOTE For specific values, see Table of Measurements

Chassis Installation

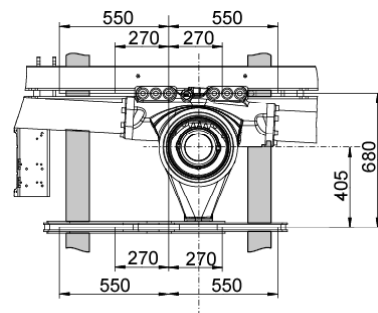

Load Diagram

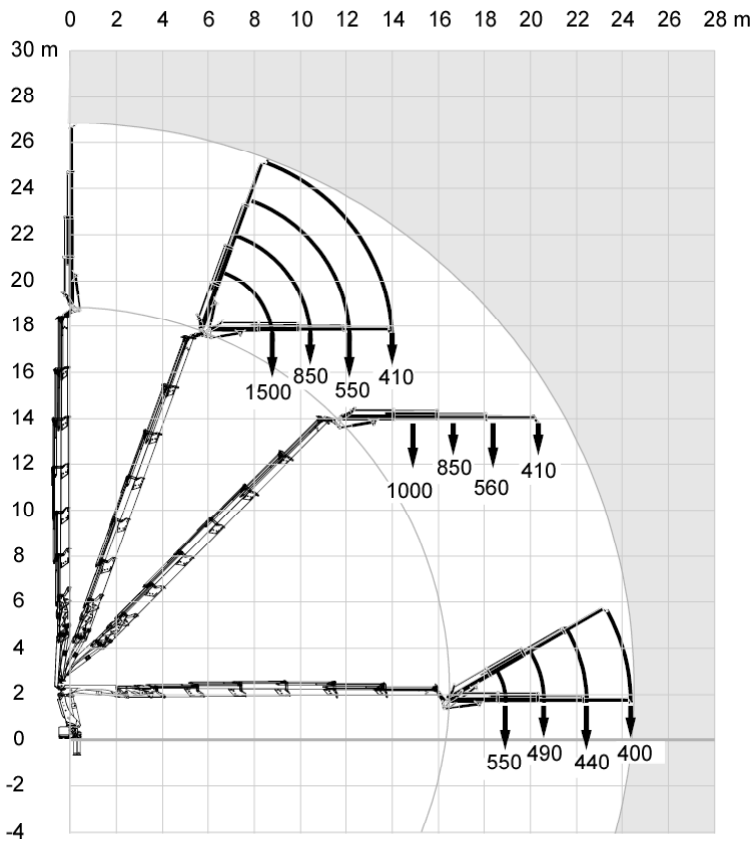

Capacity and performance

Lifting capacity with ADC	245.3 (kNm)
Lifting capacity	228.5 (kNm)
Standard lifting capacity at standard outreach with ADC	2.6 (m) - 9400 (kg)
	4.5 (m) - 5500 (kg)
	6.1 (m) - 3900 (kg)
	7.9 (m) - 2840 (kg)
	9.8 (m) - 2180 (kg)
	11.8 (m) - 1740 (kg)
	13.9 (m) - 1420 (kg)
	16.1 (m) - 1220 (kg)
Standard lifting capacity at standard outreach	2.6 (m) - 8800 (kg)
	4.5 (m) - 5200 (kg)
	6.1 (m) - 3600 (kg)
	7.9 (m) - 2620 (kg)
	9.8 (m) - 2000 (kg)
	11.8 (m) - 1580 (kg)
	13.9 (m) - 1300 (kg)
	16.1 (m) - 1100 (kg)
Manual lifting capacity at extension	18.3 (m) - 980 (kg)
	20.4 (m) - 840 (kg)
Heavy lift capacity at heavy lift outreach	2.2 (m) - 10900 (kg)
Hydraulic boom extension	11.7 (m)
Manual max outreach	23.3 (m)
Lifting height above installation level hydraulic	18.8 (m)
Lifting height above installation level manual	23.1 (m)
Slewing torque	34 (kNm)
V80 Slewing speed	15 (°/s)
Slewing angle	420 (°)
Lifting speed	2.1 m/s
Jib hydraulic outreach	24.7 (m)
Jib standard lifting capacity at standard extension	19.2 (m) - 540 (kg)
	20.8 (m) - 480 (kg)
	22.7 (m) - 430 (kg)
	24.6 (m) - 390 (kg)

Side View Unfolded Close in Area

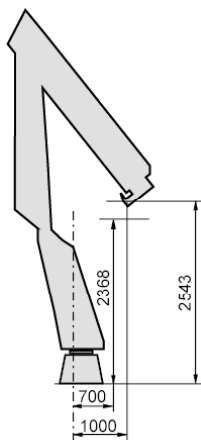

Functional demands

Recommended oil flow low	90 (l/min)
Recommended oil flow high	120 (l/min)
Working pressure	34 (MPa)
Max slope viable at full capacity	5 (°)

Weights and measurements

Height in folded position	2633 (mm)
Width in folded position	2500 (mm)
Installation space needed	1215 (mm)
Weight of crane	4020 (kg)
Weight support leg equipment	402 (kg)
Weight of crane with Jib	4020 (kg)

Side View Unfolded Stretched

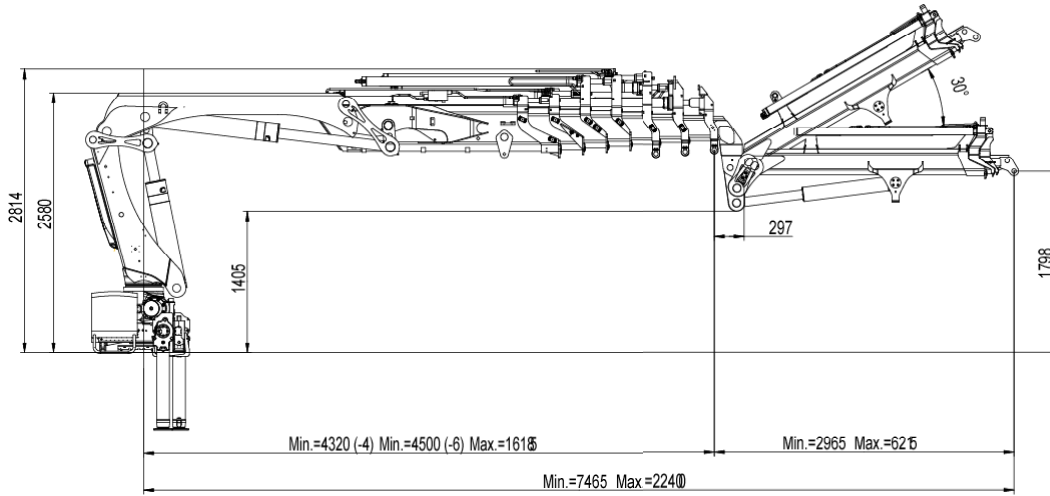

Side View Folded

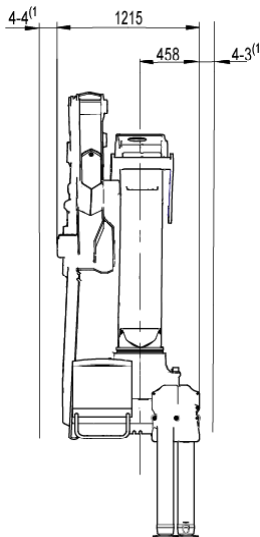

Front View Folded

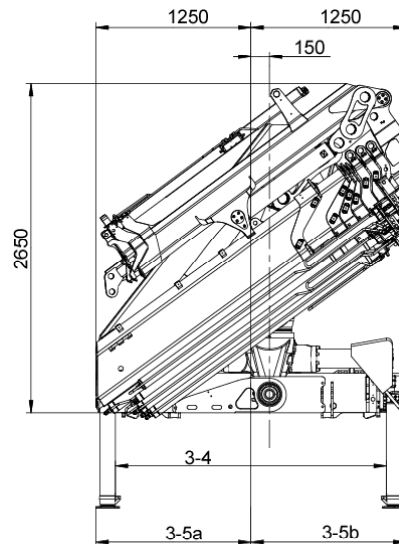

NOTE For specific values, see Table of Measurements

Top View Crane Base

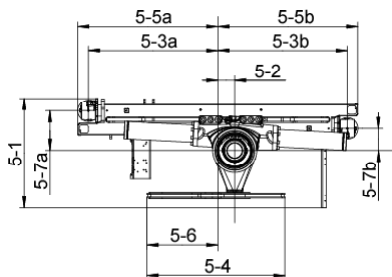

NOTE For specific values, see Table of Measurements

Chassis Installation

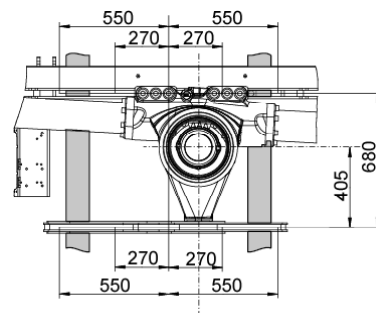

Load Diagram

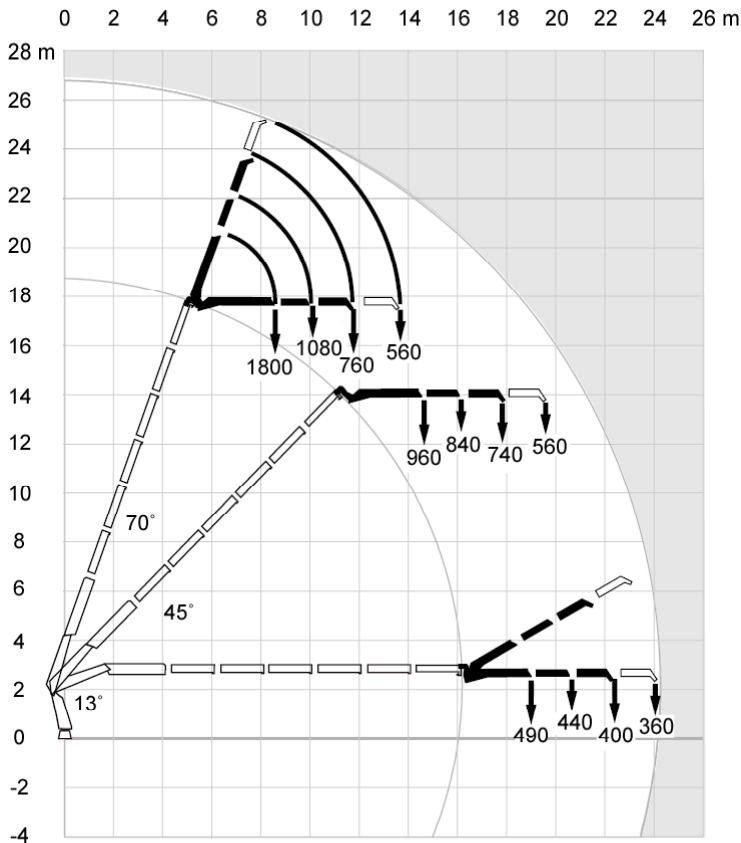

Side View Unfolded Close in Area

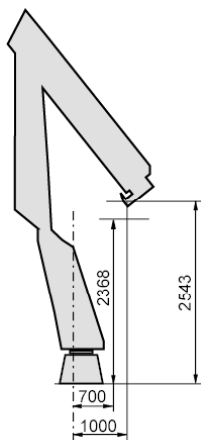

Capacity and performance

Lifting capacity with ADC	245.3 (kNm)
Lifting capacity	228.5 (kNm)
Standard lifting capacity at standard outreach with ADC	2.6 (m) - 9400 (kg)
	4.5 (m) - 5500 (kg)
	6.1 (m) - 3900 (kg)
	7.9 (m) - 2840 (kg)
	9.8 (m) - 2180 (kg)
	11.8 (m) - 1740 (kg)
	13.9 (m) - 1420 (kg)
	16.1 (m) - 1220 (kg)
Standard lifting capacity at standard outreach	2.6 (m) - 8800 (kg)
	4.5 (m) - 5200 (kg)
	6.1 (m) - 3600 (kg)
	7.9 (m) - 2620 (kg)
	9.8 (m) - 2000 (kg)
	11.8 (m) - 1580 (kg)
	13.9 (m) - 1300 (kg)
	16.1 (m) - 1100 (kg)
Manual lifting capacity at extension	18.3 (m) - 980 (kg)
	20.4 (m) - 840 (kg)
Heavy lift capacity at heavy lift outreach	2.2 (m) - 10900 (kg)
Hydraulic boom extension	11.7 (m)
Manual max outreach	23.3 (m)
Lifting height above installation level hydraulic	18.8 (m)
Lifting height above installation level manual	23.1 (m)
Slewing torque	34 (kNm)
V80 Slewing speed	15 (°/s)
Slewing angle	420 (°)
Lifting speed	2.1 (m/s)
Jib hydraulic outreach	22.4 (m)
Jib manual outreach	24.2 (m)
Jib standard lifting capacity at standard extension	19.1 (m) - 490 (kg)
	20.6 (m) - 440 (kg)
	22.3 (m) - 400 (kg)
Jib manual lifting capacity at manual extension	24.1 (m) - 360 (kg)

Functional demands

Recommended oil flow low	90 (l/min)
Recommended oil flow high	120 (l/min)
Working pressure	34 (MPa)
Max slope viable at full capacity	5 (°)

Weights and measurements

Height in folded position	2650 (mm)
Width in folded position	2500 (mm)
Installation space needed	1215 (mm)
Weight of crane	4065 (kg)
Weight support leg equipment	402 (kg)
Weight of crane with Jib	4065 (kg)

Side View Unfolded Stretched

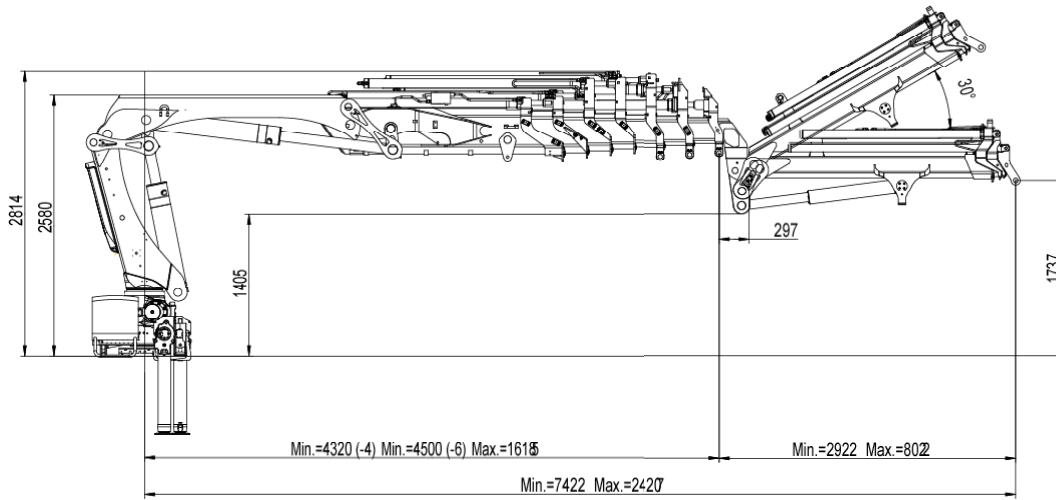

Side View Folded

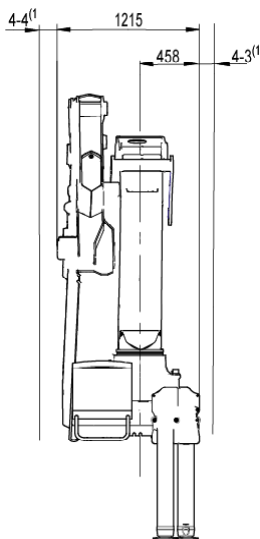

Front View Folded

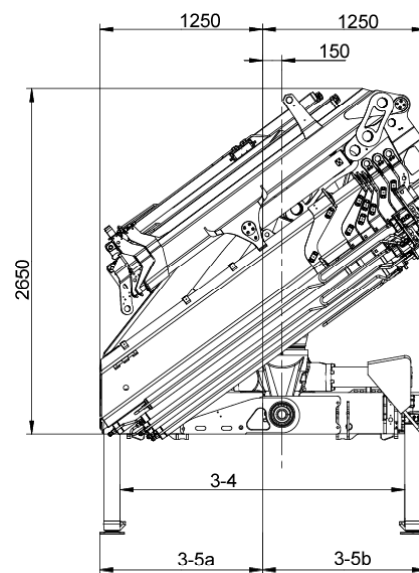

NOTE For specific values, see Table of Measurements

Top View Crane Base

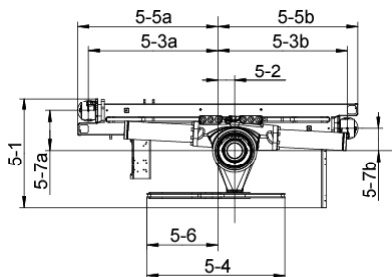

NOTE For specific values, see Table of Measurements

Chassis Installation

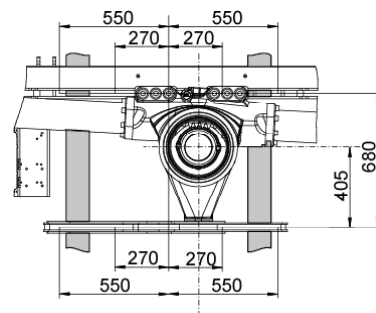

Load Diagram

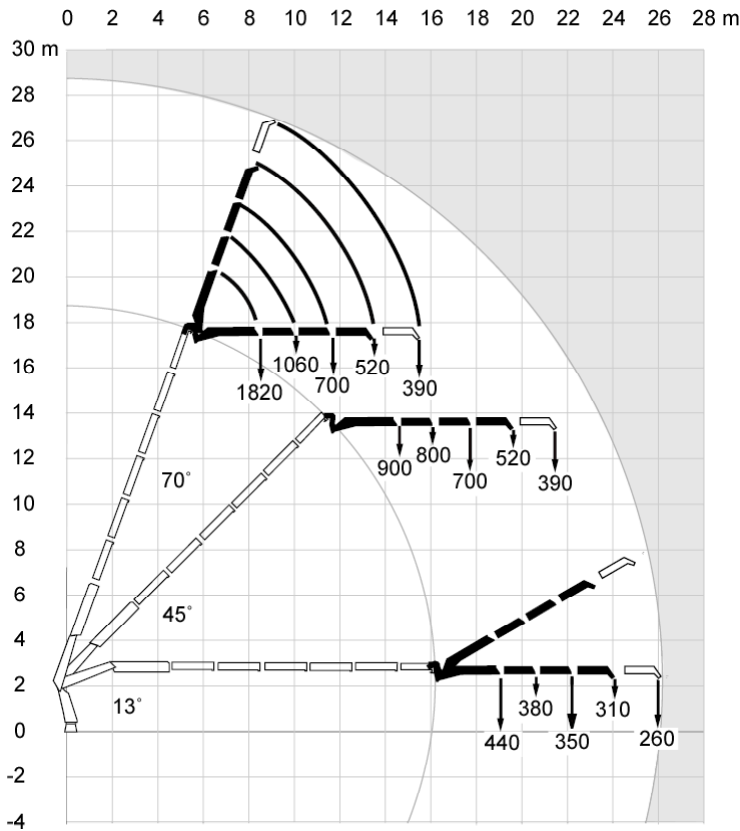

Capacity and performance

Lifting capacity with ADC	245.3 (kNm)
Lifting capacity	228.5 (kNm)
Standard lifting capacity at standard outreach with ADC	2.6 (m) - 9400 (kg)
	4.5 (m) - 5500 (kg)
	6.1 (m) - 3900 (kg)
	7.9 (m) - 2840 (kg)
	9.8 (m) - 2180 (kg)
	11.8 (m) - 1740 (kg)
	13.9 (m) - 1420 (kg)
	16.1 (m) - 1220 (kg)
Standard lifting capacity at standard outreach	2.6 (m) - 8800 (kg)
	4.5 (m) - 5200 (kg)
	6.1 (m) - 3600 (kg)
	7.9 (m) - 2620 (kg)
	9.8 (m) - 2000 (kg)
	11.8 (m) - 1580 (kg)
	13.9 (m) - 1300 (kg)
	16.1 (m) - 1100 (kg)
Manual lifting capacity at extension	18.3 (m) - 980 (kg)
	20.4 (m) - 840 (kg)
Heavy lift capacity at heavy lift outreach	2.2 (m) - 10900 (kg)
Hydraulic boom extension	11.7 (m)
Manual max outreach	23.3 (m)
Lifting height above installation level hydraulic	18.8 (m)
Lifting height above installation level manual	23.1 (m)
Slewing torque	34 (kNm)
V80 Slewing speed	15 (°/s)
Slewing angle	420 (°)
Lifting speed	2.1 (m/s)
Jib hydraulic outreach	24.2 (m)
Jib manual outreach	26.2 (m)
Jib standard lifting capacity at standard extension	19.1 (m) - 420 (kg)
	20.6 (m) - 370 (kg)
	22.2 (m) - 330 (kg)
	24.1 (m) - 300 (kg)
Jib manual lifting capacity at manual extension	26.1 (m) - 250 (kg)

Side View Unfolded Close in Area

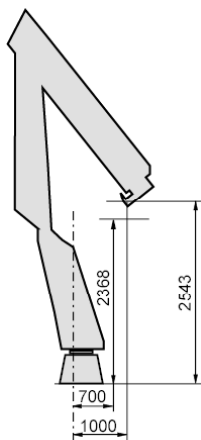

Functional demands

Recommended oil flow low	90 (l/min)
Recommended oil flow high	120 (l/min)
Working pressure	34 (MPa)
Max slope viable at full capacity	5 (°)

Weights and measurements

Height in folded position	2650 (mm)
Width in folded position	2500 (mm)
Installation space needed	1215 (mm)
Weight of crane	4145 (kg)
Weight support leg equipment	402 (kg)
Weight of crane with Jib	4145 (kg)

Side View Unfolded Stretched

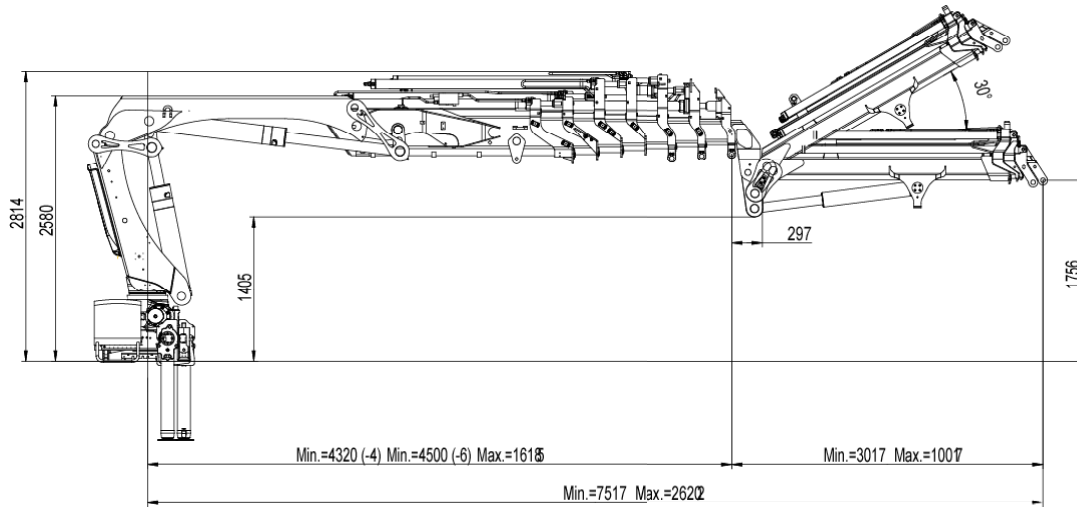

Side View Folded

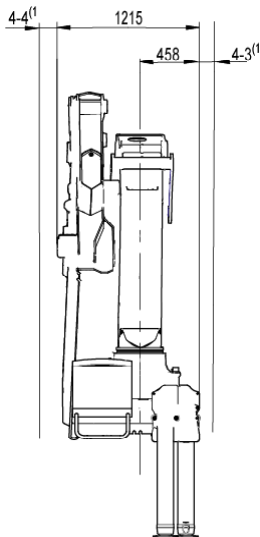

Front View Folded

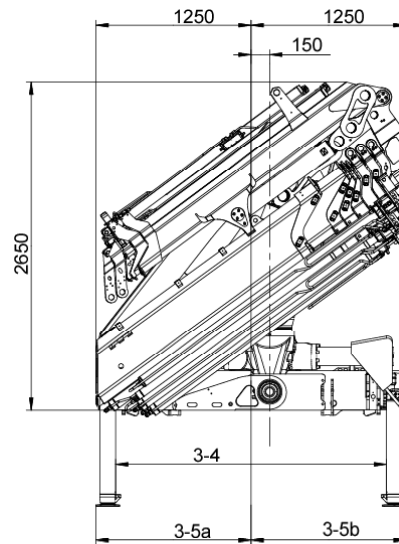

NOTE For specific values, see Table of Measurements

Top View Crane Base

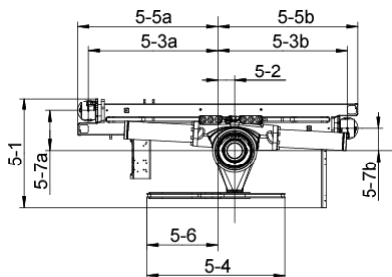

NOTE For specific values, see Table of Measurements

Chassis Installation

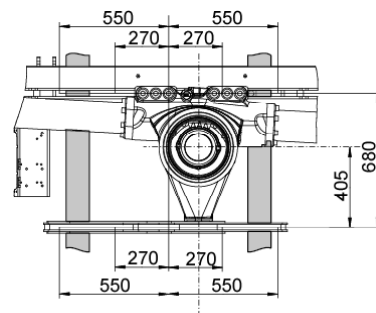

Load Diagram

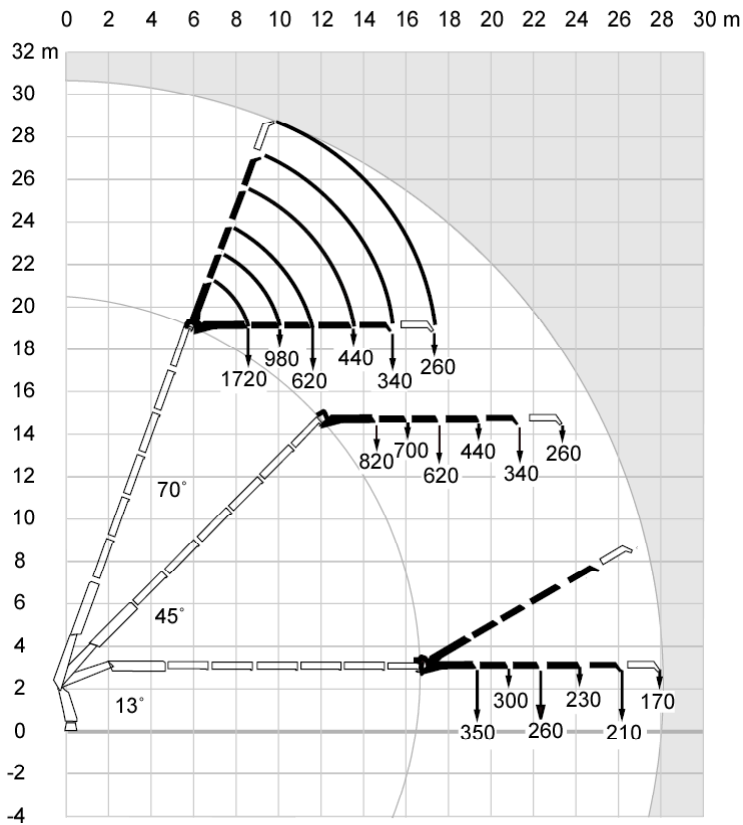

Capacity and performance

Lifting capacity with ADC	245.3 (kNm)
Lifting capacity	228.5 (kNm)
Standard lifting capacity at standard outreach with ADC	2.6 (m) - 9400 (kg)
	4.5 (m) - 5500 (kg)
	6.1 (m) - 3900 (kg)
	7.9 (m) - 2840 (kg)
	9.8 (m) - 2180 (kg)
	11.8 (m) - 1740 (kg)
	13.9 (m) - 1420 (kg)
	16.1 (m) - 1220 (kg)
Standard lifting capacity at standard outreach	2.6 (m) - 8800 (kg)
	4.5 (m) - 5200 (kg)
	6.1 (m) - 3600 (kg)
	7.9 (m) - 2620 (kg)
	9.8 (m) - 2000 (kg)
	11.8 (m) - 1580 (kg)
	13.9 (m) - 1300 (kg)
	16.1 (m) - 1100 (kg)
Manual lifting capacity at extension	18.3 (m) - 980 (kg)
	20.4 (m) - 840 (kg)
Heavy lift capacity at heavy lift outreach	2.2 (m) - 10900 (kg)
Hydraulic boom extension	11.7 (m)
Manual max outreach	23.3 (m)
Lifting height above installation level hydraulic	18.8 (m)
Lifting height above installation level manual	23.1 (m)
Slewing torque	34 (kNm)
V80 Slewing speed	15 (°/s)
Slewing angle	420 (°)
Lifting speed	2.1 (m/s)
Jib hydraulic outreach	26.2 (m)
Jib manual outreach	28.1 (m)
Jib standard lifting capacity at standard extension	19.2 (m) - 330 (kg)
	20.7 (m) - 280 (kg)
	22.3 (m) - 240 (kg)
	24.2 (m) - 200 (kg)
	26.1 (m) - 180 (kg)
Jib manual lifting capacity at manual extension	28.0 (m) - 140 (kg)

Side View Unfolded Close in Area

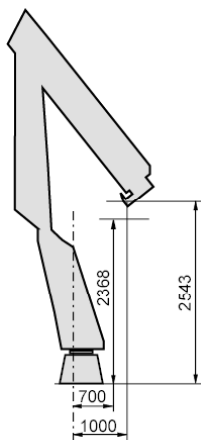

Functional demands

Recommended oil flow low	90 (l/min)
Recommended oil flow high	120 (l/min)
Working pressure	34 (MPa)
Max slope viable at full capacity	5 (°)

Weights and measurements

Height in folded position	2650 (mm)
Width in folded position	2500 (mm)
Installation space needed	1215 (mm)
Weight of crane	4225 (kg)
Weight support leg equipment	402 (kg)
Weight of crane with Jib	4225 (kg)

General Technical Data

Height Stretched Diagram

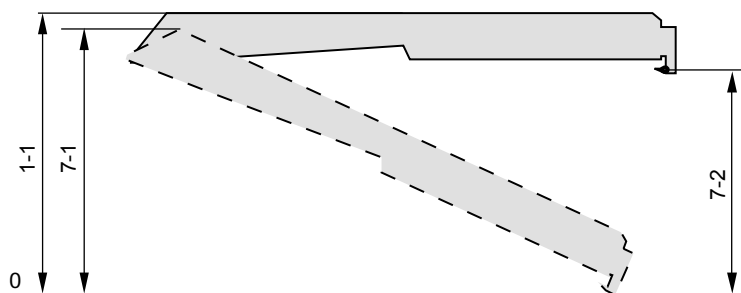

Crane	1-1 (mm)	7-1 (mm)	7-2 (mm)
HIAB XS 288 E-4	2814	2470	1996
HIAB XS 288 E-5	2814	2470	2014
HIAB XS 288 E-6	2814	2470	2033
HIAB XS 288 E-7	2814	2470	2051
HIAB XS 288 E-8	2814	2470	2085
HIAB XS 288 EP-2	2644	2470	1989
HIAB XS 288 EP-3	2644	2470	2008
HIAB XS 288 EP-4	2644	2470	2010
HIAB XS 288 EP-5	2644	2470	2026

Rotation Diagram

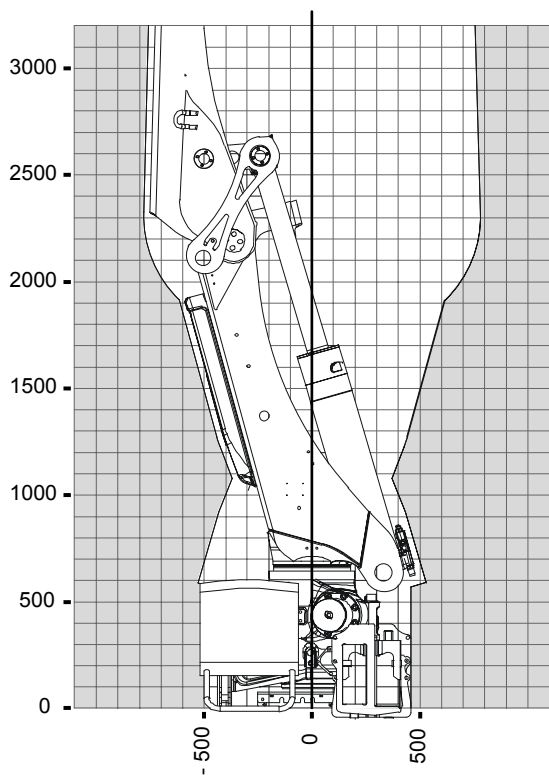

Table of Measurements

To find a configuration of stabilizer legs that match your application first choose a configuration of your choice in **Stabilizer Configuration**. Second, find the measurements in **Dimensions & Measurements**.

Stabilizer Configuration

		Configuration 1-12											
		1	2	3	4	5	6	7	8	9	10	11	12
Stabilizer extension	Medium	•	•			•	•			•	•		
	Long			•	•			•	•			•	•
Stabilizer extension operation	Hydraulic Ext	•	•	•	•	•	•	•	•	•	•	•	•
Stabilizer leg fitting	Man tilt	•	•	•	•								
	Mech tilt, Ext					•	•	•	•				
	Mech tilt, Stab leg									•	•	•	•
Stabilizer leg	Medium	•		•		•		•		•		•	
	Long		•		•		•		•		•		•

Dimensions & Measurements

Front View Folded

Top View Crane Base

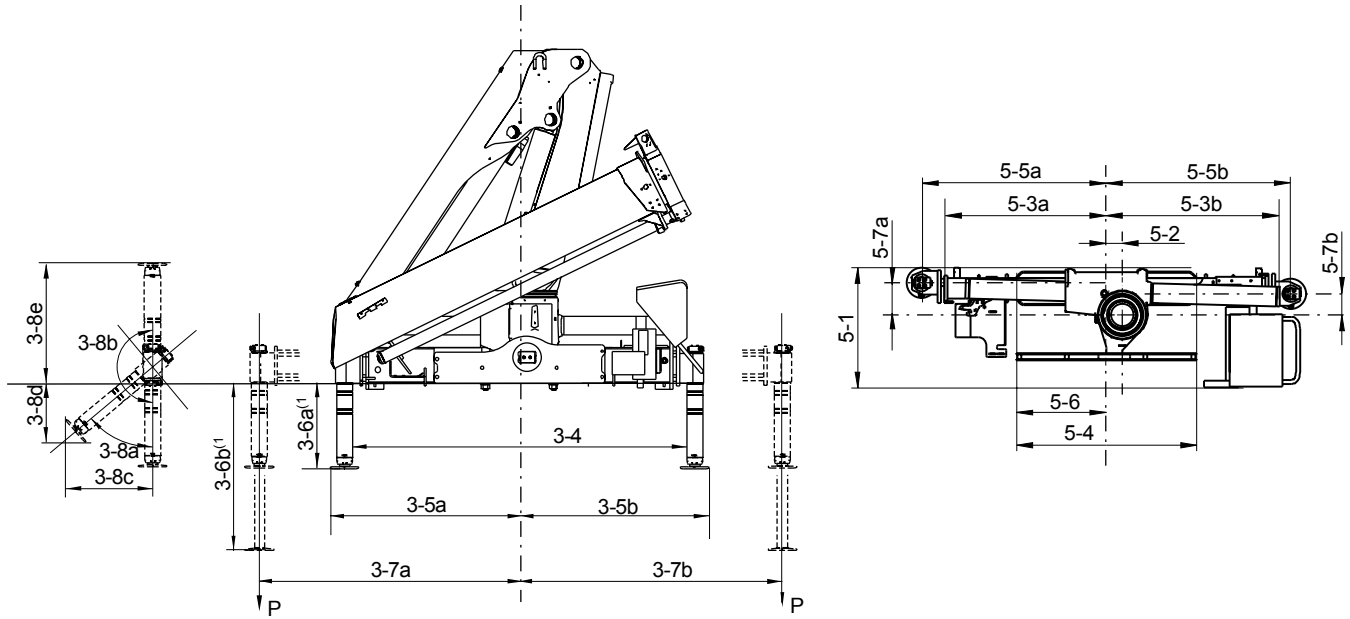

Configuration 1-10

		1	2	3	4	5	6	7	8	9	10	
Dimensions & Measurements	3-4	mm	2185	2185	2185	2185	2185	2185	2185	2185	2185	
	3-5a	mm	1250	1250	1250	1250	1250	1250	1250	1250	1250	
	3-5b	mm	1250	1250	1250	1250	1250	1250	1250	1250	1250	
	3-6a ⁽¹⁾	mm	770	870	770	870	770	870	770	870	870	
	3-6b ⁽¹⁾	mm	1400	1600	1400	1600	1400	1600	1400	1600	1600	
	3-7a	mm	2895	2895	3477	3477	2895	2895	3477	3477	2895	2895
	3-7b	mm	2895	2895	3477	3477	2895	2895	3477	3477	2895	2895
	3-8a	deg	50	50	50	50	50	50	50	50	50	50
	3-8b	deg	170	170	170	170	170	170	170	170	170	170
	3-8c	mm	820	895	820	895	820	895	820	895	820	895
	3-8d	mm	490	490	490	490	490	490	490	490	490	490
	3-8e	mm	1210	1310	1210	1310	1210	1310	1210	1310	1210	1310
	5-1	mm	977	977	977	977	977	977	977	977	977	977
	5-2	mm	150	150	150	150	150	150	150	150	150	150
	5-3a	mm	1250	1250	1250	1250	1250	1250	1250	1250	1250	1250
	5-3b	mm	1250	1250	1250	1250	1250	1250	1250	1250	1250	1250
	5-4	mm	1229	1229	1229	1229	1229	1229	1229	1229	1229	1229
	5-5a	mm	1155	1155	1155	1155	1155	1155	1155	1155	1155	1155
	5-5b	mm	1155	1155	1155	1155	1155	1155	1155	1155	1155	1155
	5-6	mm	631	631	631	631	631	631	631	631	631	631
5-7a	mm	354	354	354	354	354	354	354	354	354	354	
5-7b	mm	196	196	196	196	196	196	196	196	196	196	
P	kN	115	115	95	95	115	115	95	95	115	115	
Weight	kg	402	410	459	467	413	421	470	478	422	430	

		Configuration 11-12		
		11	12	
Dimensions & Measurements	3-4	mm	2185	2185
	3-5a	mm	1250	1250
	3-5b	mm	1250	1250
	3-6a ⁽¹⁾	mm	770	870
	3-6b ⁽¹⁾	mm	1400	1600
	3-7a	mm	3477	3477
	3-7b	mm	3477	3477
	3-8a	deg	50	50
	3-8b	deg	170	170
	3-8c	mm	820	895
	3-8d	mm	490	490
	3-8e	mm	1210	1310
	5-1	mm	977	977
	5-2	mm	150	150
	5-3a	mm	1250	1250
	5-3b	mm	1250	1250
	5-4	mm	1229	1229
	5-5a	mm	1155	1155
	5-5b	mm	1155	1155
	5-6	mm	631	631
	5-7a	mm	354	354
	5-7b	mm	196	196
	P	kN	95	95
Weight	kg	479	487	

NOTES

A series of horizontal dotted lines for writing notes.

NOTES

A series of 25 horizontal dotted lines for writing notes.



Hiab is part of Cargotec Corporation

