

**AC 80-2** | All Terrain Crane 100 t Lifting Capacity



# AC 80-2

ALL TERRAIN CRANE

AC 80-2  
HIGHLIGHTS

- ▶ Shortest 4-axle machine in its category
- ▶ Advanced high-torque DaimlerChrysler engine combined with comfortable 6-speed Allison automatic transmission ensures outstanding driving performance
- ▶ Fully hydraulic boom system for exceptionally short telescoping times and high load telescoping capacity
- ▶ Fully roadable with 17,600 lb counterweight and 30.2 ft boom extension within the statutory 26,460 lb axle load limit
- ▶ State-of-the-art DaimlerChrysler engine technology type OM 501 LA, EURO MOT 3a
- ▶ Air-conditioning in carrier and superstructure as standard
- ▶ Limitation of working range as standard
- ▶ ABS, heated seats and electric window winders included as standard

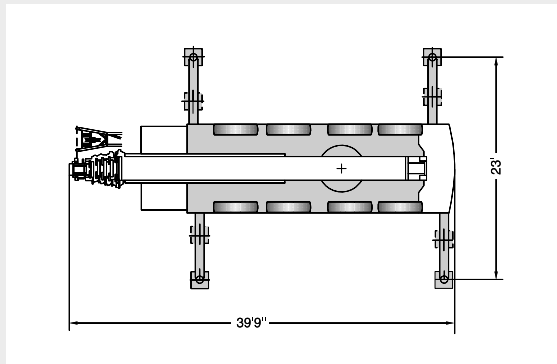
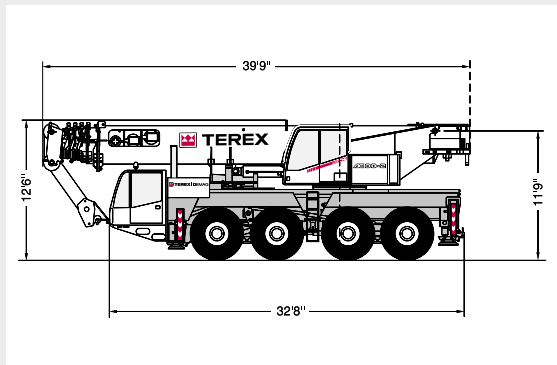

**CONTENTS**

Page:

**Specifications**

Dimensions .....	4
Specifications .....	6

1

**Main boom**

Working ranges .....	7
Lifting capacities .....	8

2

**Main boom extension**

Working ranges .....	10
Lifting capacities .....	11

3

**Technical description**

Carrier · Superstructure · Optional equipment .....	14
---	----

4

**Overview**

of standard duty charts .....	15
-------------------------------	----

5



**DIMENSIONS**

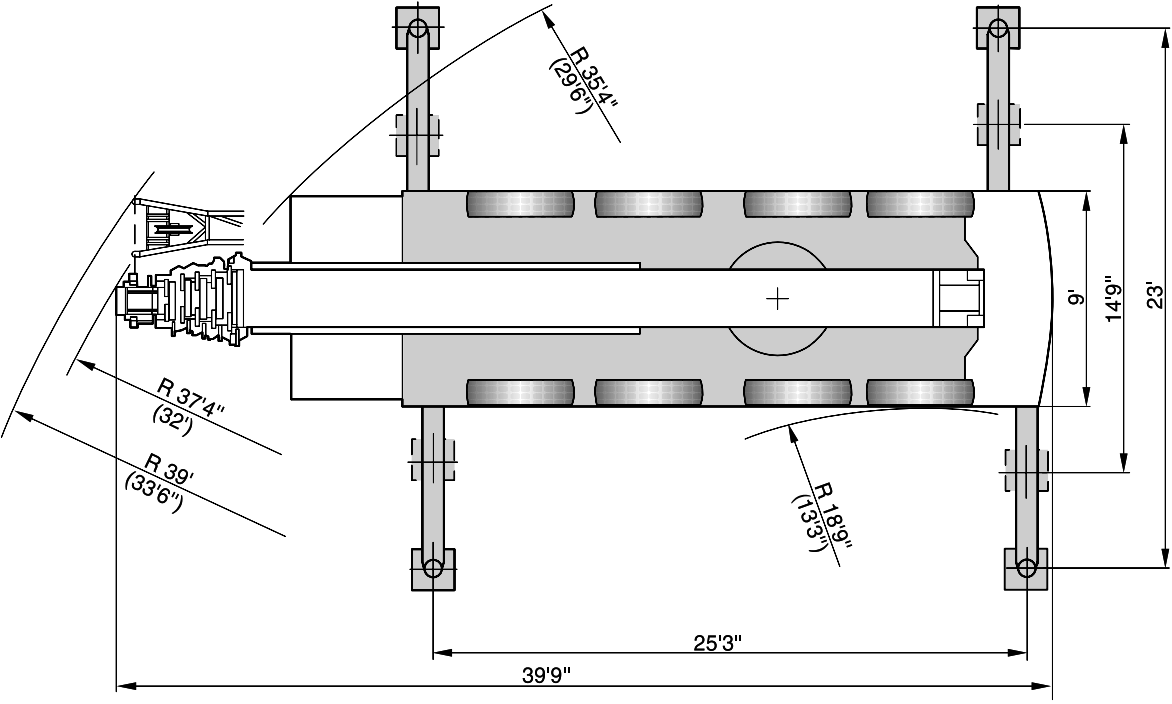
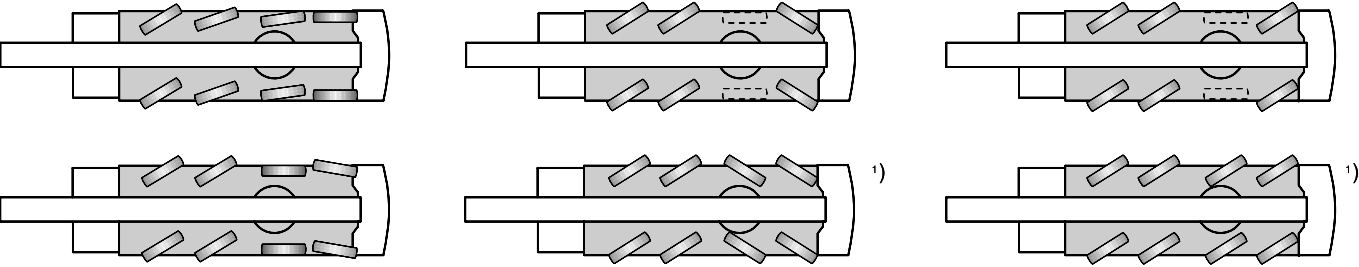

( ) with independent rear axle steering      <sup>1)</sup> optional

## SPECIFICATIONS

### AXLE LOADS

Crane with main boom, hook block 3-sheaves, 17,600 lb counterweight, tires 14.00 R 25

Axles	4 x 26,460 lb
Total weight	105,840 lb

### WORKING SPEEDS (INFINITELY VARIABLE)

Mechanisms	Normal speed	High speed	Max. permissible line pull <sup>1)</sup>	Rope length
Hoist I	174 ft/min	361 ft/min	12,100 lb	689 ft
Hoist II	174 ft/min	361 ft/min	12,100 lb	689 ft
Slewing				max. 1.3 rpm
Telescoping speed				35.8 – 164 ft: 110 s
Boom elevation				-1,8° – +81,5°: 63 s

### CARRIER PERFORMANCE

Travel speed	
Forward	0 .. 50 mph
Reverse	0 .. 7.5 mph
Gradeability in travel order	max. 50 %
Ground clearance	13 inches

### HOOK BLOCK / SINGLE LINE HOOK

Type	Possible load <sup>1)</sup>	Number of sheaves	Weight	„D“	Number of lines	Heavy-lift attachment
100	170,000 lb	7	1,650 lb	6.6 ft	14	2 add. sheaves
80	133,000 lb	5	1,430 lb	6.6 ft	11	2 add. sheaves
50	85,000 lb	3	1,210 lb	5.9 ft	7	
20	35,000 lb	1	770 lb	5.9 ft	3	
6,3	12,000 lb	Single line hook	375 lb	5.6 ft	1	

### Remarks

<sup>1)</sup> varies depending on national regulations



# HA LIFTING CAPACITIES

**39,700 lb**      **25'3" x 23'**      **360°**      **85%**

Main boom													
Radius	ft	35.8	52.8	70.2	82.0	102.7	121.7	138.8	151.2	164.0	35.8	52.8	Radius
ft		1,000 lb										1,000 lb	ft
10	200.0*	-	-	-	-	-	-	-	-	-	-	-	10
10	169.8	-	-	-	-	-	-	-	-	-	-	-	10
11	156.1	133.4	-	-	-	-	-	-	-	-	-	-	11
13	143.7	133.4	109.1	-	-	-	-	-	-	-	27.3	26.6	13
15	133.2	128.3	104.3	77.6	-	-	-	-	-	-	23.9	23.2	15
16	123.7	120.4	99.4	77.6	48.5	-	-	-	-	-	22.4	21.7	16
19	101.9	101.2	88.6	75.2	48.5	38.8	-	-	-	-	18.6	18.0	19
23	84.9	84.4	77.6	70.3	48.5	37.5	31.5	-	-	-	14.5	14.0	23
26	68.6	71.9	67.9	63.1	48.5	36.4	31.5	21.4	-	-	12.3	11.6	26
29	-	62.2	60.2	57.1	47.2	35.1	31.3	21.4	15.9	-	-	9.6	29
33	-	53.6	50.9	50.9	45.0	34.0	30.9	21.4	15.9	-	-	7.4	33
39	-	39.0	38.4	40.8	39.0	30.9	28.7	21.4	15.9	-	-	4.7	39
46	-	-	33.5	32.2	31.1	27.3	26.5	20.7	15.9	-	-	-	46
52	-	-	27.1	26.0	24.7	24.3	24.3	19.4	15.9	-	-	-	52
59	-	-	22.3	21.2	19.8	20.7	21.4	18.3	15.0	-	-	-	59
65	-	-	-	17.4	17.0	17.9	17.6	17.0	14.3	-	-	-	65
72	-	-	-	-	15.4	15.2	15.4	15.2	13.2	-	-	-	72
79	-	-	-	-	14.1	14.1	13.0	12.8	12.3	-	-	-	79
85	-	-	-	-	12.6	12.6	10.8	11.5	10.6	-	-	-	85
92	-	-	-	-	-	10.8	9.7	9.7	9.0	-	-	-	92
98	-	-	-	-	-	9.5	9.0	8.2	7.5	-	-	-	98
105	-	-	-	-	-	8.2	7.9	7.1	6.4	-	-	-	105
111	-	-	-	-	-	-	6.8	5.7	5.1	-	-	-	111
118	-	-	-	-	-	-	5.7	4.9	4.2	-	-	-	118
124	-	-	-	-	-	-	5.1	4.2	3.3	-	-	-	124
131	-	-	-	-	-	-	-	3.1	2.6	-	-	-	131
138	-	-	-	-	-	-	-	2.4	1.8	-	-	-	138

**17,600 lb**      **25'3" x 23'**      **360°**      **85%**

Main boom													
Radius	ft	35.8	52.8	70.2	82.0	102.7	121.7	138.8	151.2	164.0	35.8	52.8	Radius
ft		1,000 lb										1,000 lb	ft
10	200.0*	-	-	-	-	-	-	-	-	-	-	-	10
10	169.8	-	-	-	-	-	-	-	-	-	-	-	10
11	155.4	133.4	-	-	-	-	-	-	-	-	-	-	11
13	143.1	133.4	109.1	-	-	-	-	-	-	-	26.0	25.3	13
15	128.3	127.6	104.3	77.6	-	-	-	-	-	-	22.6	22.1	15
16	113.3	112.4	99.4	77.6	48.5	-	-	-	-	-	21.2	20.6	16
19	91.3	90.4	84.7	75.2	48.5	38.8	-	-	-	-	17.5	17.0	19
23	75.8	75.2	66.4	62.4	48.5	37.5	31.5	-	-	-	13.6	13.2	23
26	58.6	57.5	54.0	50.9	48.5	36.4	31.5	21.4	-	-	11.4	10.7	26
29	-	45.9	43.7	46.1	43.9	35.1	31.3	21.4	15.9	-	-	8.9	29
33	-	37.5	41.9	40.8	37.5	34.0	30.9	21.4	15.9	-	-	6.7	33
39	-	26.7	30.9	29.3	28.0	28.0	26.9	21.4	15.9	-	-	4.3	39
46	-	-	23.4	21.8	22.5	22.5	21.8	20.7	15.9	-	-	-	46
52	-	-	18.3	17.0	19.6	19.6	17.9	17.2	15.9	-	-	-	52
59	-	-	14.6	13.0	15.9	15.9	14.3	14.8	13.7	-	-	-	59
65	-	-	-	10.1	13.0	12.8	12.3	11.7	10.8	-	-	-	65
72	-	-	-	-	10.6	10.6	10.4	9.5	8.8	-	-	-	72
79	-	-	-	-	8.8	8.8	8.4	7.5	6.8	-	-	-	79
85	-	-	-	-	7.3	7.1	7.1	5.7	5.1	-	-	-	85
92	-	-	-	-	-	5.7	5.5	4.6	4.0	-	-	-	92
98	-	-	-	-	-	4.6	4.6	3.3	2.9	-	-	-	98
105	-	-	-	-	-	4.0	3.5	2.6	2.0	-	-	-	105
111	-	-	-	-	-	-	2.9	1.8	-	-	-	-	111
118	-	-	-	-	-	-	2.2	-	-	-	-	-	118
124	-	-	-	-	-	-	1.5	-	-	-	-	-	124

Remarks: \* over rear



**HA LIFTING CAPACITIES**

☰ 11,000 lb      🏗️ 25'3" x 23'      360°      🏠 85%

Main boom											
Radius	ft	35.8	52.8	70.2	82.0	102.7	121.7	138.8	151.2	164.0	Radius
	ft	1,000 lb									ft
10	200.0*	-	-	-	-	-	-	-	-	-	10
10	169.8	-	-	-	-	-	-	-	-	-	10
11	155.4	133.4	-	-	-	-	-	-	-	-	11
13	142.4	133.4	109.1	-	-	-	-	-	-	-	13
15	123.9	123.2	104.3	77.6	-	-	-	-	-	-	15
16	109.3	108.7	99.4	77.6	48.5	-	-	-	-	-	16
19	88.0	87.3	75.0	69.7	48.5	38.8	-	-	-	-	19
23	67.9	67.0	58.6	54.9	48.5	37.5	31.5	-	-	-	23
26	51.8	50.9	47.2	46.1	45.6	36.4	31.5	21.4	-	-	26
29	-	40.6	43.7	43.4	38.1	34.8	31.3	21.4	15.9	-	29
33	-	32.8	37.5	36.2	32.2	31.3	30.4	21.4	15.9	-	33
39	-	22.5	26.7	25.1	25.6	24.7	24.0	21.4	15.9	-	39
46	-	-	19.8	18.7	21.6	21.6	19.0	17.9	15.9	-	46
52	-	-	15.4	14.1	17.0	16.8	15.0	15.0	13.9	-	52
59	-	-	12.1	10.6	13.7	13.2	13.2	12.1	11.2	-	59
65	-	-	-	7.9	10.8	10.6	10.6	9.5	8.8	-	65
72	-	-	-	-	8.8	8.4	8.4	7.3	6.6	-	72
79	-	-	-	-	7.1	6.8	6.8	5.5	4.9	-	79
85	-	-	-	-	5.5	5.5	5.3	4.4	3.5	-	85
92	-	-	-	-	-	4.4	4.2	3.1	2.4	-	92
98	-	-	-	-	-	3.3	3.1	2.2	1.5	-	98
105	-	-	-	-	-	2.4	2.4	-	-	-	105
111	-	-	-	-	-	-	1.8	-	-	-	111



**HAV** WORKING RANGES

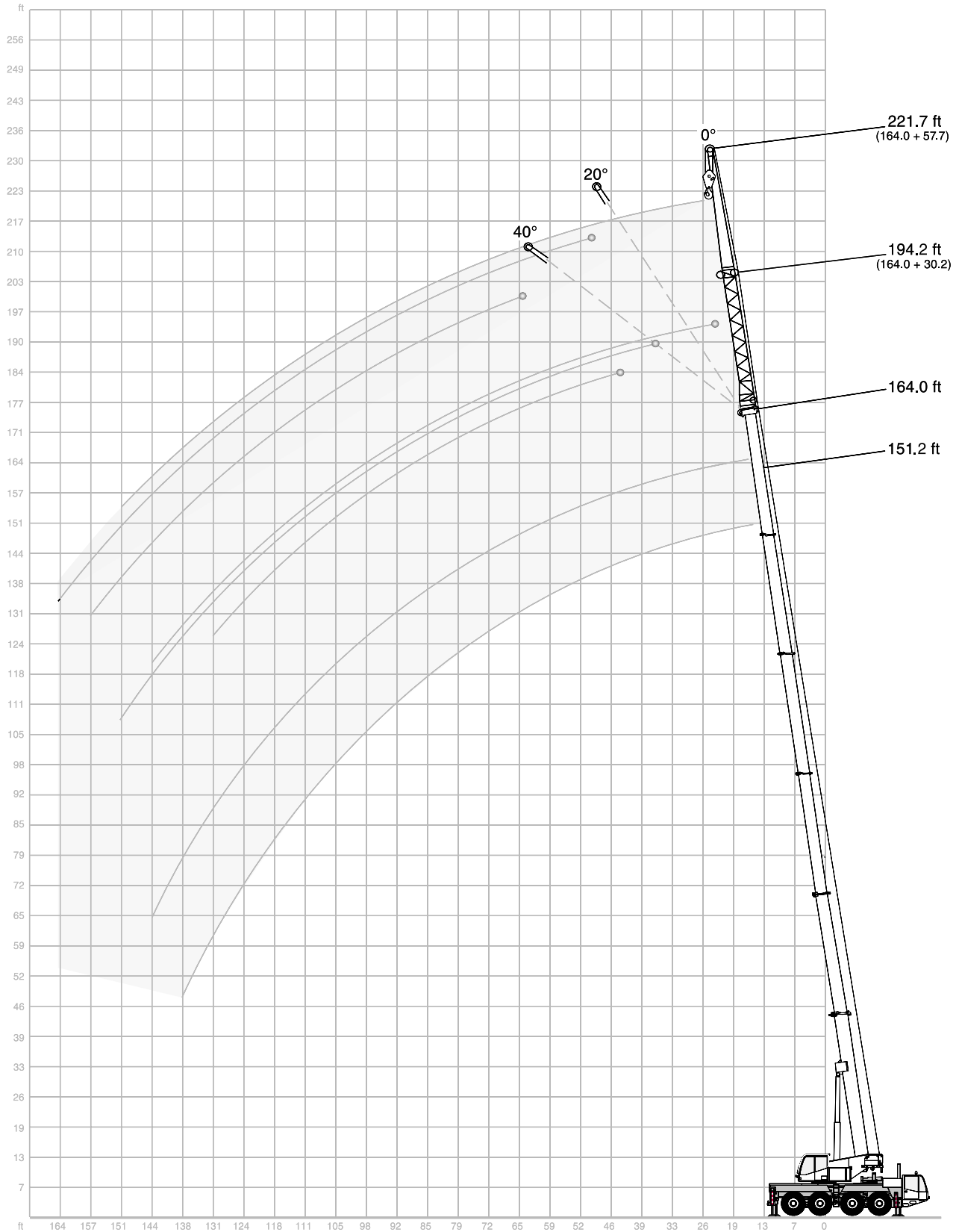

**HAV** LIFTING CAPACITIES

39,700 lb 25'3" x 23' 360° 85%

151.2 ft Main boom		Extension					
		30.2 ft			57.7 ft		
Radius	0°	20°	40°	0°	20°	40°	
ft	1,000 lb						
33	9.5	-	-	-	-	-	
39	9.5	-	-	4.2	-	-	
46	9.5	8.2	-	4.2	-	-	
52	9.5	8.2	7.3	4.2	-	-	
59	9.5	7.9	7.3	4.2	3.3	-	
65	9.0	7.7	7.1	4.0	3.3	-	
72	8.4	7.5	6.8	3.5	3.3	-	
79	7.9	7.1	6.6	3.5	3.3	2.9	
85	7.5	6.8	6.4	3.3	3.3	2.6	
92	7.3	6.4	6.2	3.3	3.3	2.6	
98	6.8	6.2	5.7	3.1	3.1	2.6	
105	6.6	5.7	5.5	3.1	2.9	2.6	
111	5.7	5.5	5.3	2.9	2.6	2.6	
118	4.9	5.3	5.1	2.9	2.6	2.6	
124	4.0	4.4	4.6	2.6	2.6	2.4	
131	3.1	3.5	4.0	2.6	2.6	2.4	
138	2.4	2.9	-	2.6	2.6	2.4	
144	2.0	2.2	-	2.4	2.6	2.4	
151	-	1.5	-	2.0	2.6	2.4	
157	-	-	-	1.5	2.0	2.4	
164	-	-	-	-	1.5	-	

17,600 lb 25'3" x 23' 360° 85%

151.2 ft Main boom		Extension					
		30.2 ft			57.7 ft		
Radius	0°	20°	40°	0°	20°	40°	
ft	1,000 lb						
33	9.5	-	-	-	-	-	
39	9.5	-	-	4.2	-	-	
46	9.5	8.2	-	4.2	-	-	
52	9.5	8.2	7.3	4.2	-	-	
59	9.5	7.9	7.3	4.2	3.3	-	
65	9.0	7.7	7.1	4.0	3.3	-	
72	8.4	7.5	6.8	3.5	3.3	-	
79	7.5	7.1	6.6	3.5	3.3	2.9	
85	5.7	6.8	6.4	3.3	3.3	2.6	
92	4.6	5.5	6.2	3.3	3.3	2.6	
98	3.3	4.4	4.9	3.1	3.1	2.6	
105	2.4	3.1	3.5	3.1	2.9	2.6	
111	1.8	2.4	2.6	2.4	2.6	2.6	
118	-	1.5	2.0	1.8	2.6	2.6	
124	-	-	-	-	2.0	2.4	
131	-	-	-	-	1.5	2.2	
138	-	-	-	-	-	1.5	
144	-	-	-	-	-	-	
151	-	-	-	-	-	-	
157	-	-	-	-	-	-	
164	-	-	-	-	-	-	

164.0 ft Main boom

164.0 ft Main boom		Extension					
		30.2 ft			57.7 ft		
Radius	0°	20°	40°	0°	20°	40°	
ft	1,000 lb						
39	7.3	-	-	-	-	-	
46	7.3	7.3	-	2.9	-	-	
52	7.3	7.3	6.6	2.9	-	-	
59	7.3	7.1	6.6	2.9	-	-	
65	7.1	6.8	6.4	2.9	2.6	-	
72	6.8	6.6	6.2	2.6	2.6	-	
79	6.4	6.2	5.5	2.6	2.6	2.4	
85	6.2	5.7	5.3	2.4	2.6	2.4	
92	5.5	5.3	5.1	2.4	2.4	2.4	
98	5.3	5.1	4.9	2.4	2.4	2.4	
105	5.1	4.9	4.6	2.4	2.4	2.4	
111	4.9	4.6	4.6	2.2	2.4	2.4	
118	4.6	4.4	4.4	2.2	2.2	2.2	
124	3.5	4.4	4.4	2.2	2.2	2.2	
131	2.9	3.3	4.0	2.0	2.2	2.2	
138	2.2	2.6	-	2.0	2.2	2.2	
144	1.8	2.2	-	1.8	2.0	2.2	
151	-	1.5	-	1.8	2.0	2.0	
157	-	-	-	-	2.0	2.0	
164	-	-	-	-	1.5	-	
170	-	-	-	-	-	-	

164.0 ft Main boom

164.0 ft Main boom		Extension					
		30.2 ft			57.7 ft		
Radius	0°	20°	40°	0°	20°	40°	
ft	1,000 lb						
39	7.3	-	-	-	-	-	
46	7.3	7.3	-	2.9	-	-	
52	7.3	7.3	6.6	2.9	-	-	
59	7.3	7.1	6.6	2.9	-	-	
65	7.1	6.8	6.4	2.9	2.6	-	
72	6.8	6.6	6.2	2.6	2.6	-	
79	6.4	6.2	5.5	2.6	2.6	2.4	
85	5.7	5.7	5.3	2.4	2.6	2.4	
92	4.4	5.3	5.1	2.4	2.4	2.4	
98	3.3	4.2	4.9	2.4	2.4	2.4	
105	2.4	3.1	3.5	2.4	2.4	2.4	
111	1.5	2.2	2.6	2.2	2.4	2.4	
118	-	1.5	2.0	1.5	2.2	2.2	
124	-	-	-	-	2.0	2.2	
131	-	-	-	-	-	2.0	
138	-	-	-	-	-	-	
144	-	-	-	-	-	-	
151	-	-	-	-	-	-	
157	-	-	-	-	-	-	
164	-	-	-	-	-	-	
170	-	-	-	-	-	-	

3

# HAV LIFTING CAPACITIES

11,000 lb 25'3" x 23' 360° 85 %

		Extension					
		30.2 ft			57.7 ft		
Radius		0°	20°	40°	0°	20°	40°
ft		1,000 lb					
33		9.5	-	-	-	-	-
39		9.5	-	-	4.2	-	-
46		9.5	8.2	-	4.2	-	-
52		9.5	8.2	7.3	4.2	-	-
59		9.5	7.9	7.3	4.2	3.3	-
65		9.0	7.7	7.1	4.0	3.3	-
72		7.5	7.5	6.8	3.5	3.3	-
79		5.5	6.8	6.6	3.5	3.3	2.9
85		4.4	5.3	6.2	3.3	3.3	2.6
92		3.1	4.2	4.6	3.3	3.3	2.6
98		2.0	2.9	3.3	2.6	3.1	2.6
105		-	2.0	2.4	2.0	2.9	2.6
111		-	-	1.5	-	2.4	2.6
118		-	-	-	-	1.8	2.6
124		-	-	-	-	-	2.0

		Extension					
		30.2 ft			57.7 ft		
Radius		0°	20°	40°	0°	20°	40°
ft		1,000 lb					
39		7.3	-	-	-	-	-
46		7.3	7.3	-	2.9	-	-
52		7.3	7.3	6.6	2.9	-	-
59		7.3	7.1	6.6	2.9	-	-
65		7.1	6.8	6.4	2.9	2.6	-
72		6.8	6.6	6.2	2.6	2.6	-
79		5.3	6.2	5.5	2.6	2.6	2.4
85		4.2	5.1	5.3	2.4	2.6	2.4
92		2.9	4.0	4.6	2.4	2.4	2.4
98		2.0	2.9	3.3	2.4	2.4	2.4
105		-	2.0	2.4	1.5	2.4	2.4
111		-	-	1.5	-	2.2	2.4
118		-	-	-	-	1.5	2.2
124		-	-	-	-	-	1.8
131		-	-	-	-	-	-

## NOTES TO LIFTING CAPACITY

Lifting capacities do not exceed 85% of tipping load.

Weight of hook blocks and slings is part of the load, and is to be deducted from the capacity ratings.

Consult operation manual for further details.

**Note:** Data published herein is intended as a guide only and shall not be construed to warrant applicability for lifting purposes. Crane operation is subject to the computer charts and operation manual both supplied with the crane.

## KEY

 Counterweight

 Lifting capacities on outriggers 360°

 free on wheels, 0° over rear

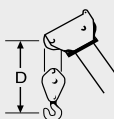
„D“ 

HA: Main boom

HAV: Main boom extension

## TECHNICAL DESCRIPTION

### CARRIER

<b>Drive / Steering</b>	8 x 6 x 6.
<b>Frame</b>	Monobox main frame with outrigger boxes integral, of high-strength fine-grain structural steel.
<b>Outriggers</b>	Four hydraulically telescoping outrigger beams with hydraulic jack legs.
<b>Engine</b>	Water-cooled 6 cylinder DaimlerChrysler engine OM 501 LA, output to DIN: 315 kW (428 hp) at 1800 <sup>1</sup> /min, max. torque 2000 Nm at 1300 <sup>1</sup> /min, certified in compliance with EURO MOT 3a, Tier 3 and CARB, stainless steel exhaust system with spark arrestor. Tank capacity: 106 gallons.
<b>Transmission</b>	Allison automatic transmission, transfer case with off-road range.
<b>Axles</b>	1st: steering. 2nd: steering. 3rd: rigid, non-steering, 4th: steering. Axles 1, 2 and 4 with planetary hubs. Differential lock-out control on 2nd axle: longitudinal and transverse. 1st and 4th axle: transverse.
<b>Suspension</b>	Hydropneumatic suspension, all axles hydraulically blockable.
<b>Wheels and tires</b>	8 x 14.00 R 25 on 11.25-25 rims; tubeless road-tread tires, all axles single-wheeled.
<b>Steering</b>	Dual-circuit semiblock mechanical steering with hydraulic booster.
<b>Brakes</b>	Service brake: dual-line air system with ABS, acting on all wheels. Parking brake: spring-loaded type. Sustained action brake: engine exhaust brake and constant decompression valve, automatic downhill brake control.
<b>Travel speed</b>	50 mph, brake control.
<b>Electrical equipment</b>	24 V.
<b>2-man driver's cab</b>	Rubber-mounted steel cab with safety glass, carrier controls, air-sprung and heated driver's and passenger seat with integrated seat belts, height and tilt adjustable steering wheel, electric window winders, electrically adjustable and heated outside mirrors, cruise control, radio with CD-player, rotary beacon, air-conditioning.

### SUPERSTRUCTURE

<b>Hydraulic system</b>	Driven off carrier engine at low revs, 1 variable-displacement axial piston pump and separate fixed-displacement pump for 4 simultaneous, independent working movements.
<b>Hoist</b>	Fixed-displacement axial-piston motor, hoist drum with planetary reduction integral and spring-applied holding brake.
<b>Slew unit</b>	Hydraulic motor with planetary reduction, foot-pedal brake and spring-applied holding brake.
<b>Derricking unit</b>	1 differential cylinder with pilot-controlled lowering brake valve.
<b>Crane cab</b>	Spacious all-steel comfortable cab with sliding door and large hinged windscreen, roof window with armoured glass, controls and instrumentation for all crane movements, working lights, self-contained hot water heater with timer, thermostat-controlled, windscreen washer and wiper with intermittent control, cab tiltable up to 18°, radio with CD-player, air-conditioning.
<b>Main boom</b>	Boom base and 5 telescopic sections of fine-grain structural steel, telescoping with partial load, buckling-resistant Demag ovaloid design.
<b>Counterweight</b>	17,600 lb in sections of 11,250 lb, 3,750 lb and 2,650 lb (15,000 lb fitted on superstructure, 2,650 lb hydraulically stowed on carrier deck).
<b>Top steer facility</b>	Included as standard.
<b>Operator aids</b>	Electronic load indicator with digital read-out for hook load, rated load, boom length, boom angle, load radius, analog display to indicate the capacity utilization. Limit switches on hoist and lowering motions, pressure-relief and safety holding valves.
<b>Hydraulic servo control</b>	Hydraulic pilot control through self-centering control levers.

### OPTIONAL EQUIPMENT

<b>Drive / Steering</b>	8 x 8 x 8.
<b>Tires</b>	Optional 16.00 R 25, 17.5 R 25 or 20.5 R 25.
<b>Telma brake</b>	
<b>Trailer coupling</b>	For central axle trailers with max. 52,920 lb total weight and ABS air hookup: D = 190; D <sub>C</sub> = 155; V = 75.
<b>Hoist II</b>	Fixed displacement axial-piston motor, hoist drum with planetary reduction integral and spring-applied holding brake. Hoist II avoids re-reeving of hoist line when using the optional jib.
<b>Main boom extension</b>	1- or 2-part folding jib, 30.2 ft or 57.7 ft. 0°, 20° and 40° offset.
<b>Additional counterweight</b>	22,050 lb, integrated into standard counterweight, installed hydraulically by the crane itself.
<b>Heavy-lift attachment</b>	Additional sheaves on boom head for duties over 132,300 lb.
<b>Heavy-lift runner</b>	3.9 ft long, 1-sheave.
<b>Centralized lubrication carrier</b>	
<b>Stowing point for hook block</b>	For 1 sheave and 3-sheaves hook blocks or for 5-sheaves hook block, for single line hook block.
<b>Tackle box on the rear of the carrier</b>	

**OVERVIEW OF STANDARD DUTY CHARTS**



25'3" x 23'



25'3" x 14'8"

**Main boom**

Main boom			
	11,000 lb	17,600 lb	39,700 lb
35.8 ft	X	X	X
52.8 ft	X	X	X
70.2 ft	X	X	X
82.0 ft	X	X	X
102.8 ft	X	X	X
121.9 ft	X	X	X
138.9 ft	X	X	X
151.3 ft	X	X	X
164.0 ft	X	X	X

Main boom			
	11,000 lb	17,600 lb	39,700 lb
35.8 ft	X	X	X
52.8 ft	X	X	X
70.2 ft	X	X	X
82.0 ft	X	X	X
102.8 ft	X	X	X
121.9 ft	X	X	X
138.9 ft	X	X	X
151.3 ft	X	X	X
164.0 ft	X	X	X

**Main boom extension**

Main boom	Main boom extension 0° / 20° / 40°			
		11,000 lb	17,600 lb	39,700 lb
151.3 ft	30.2 ft	X	X	X
	57.7 ft	X	X	X
164.0 ft	30.2 ft	X	X	X
	57.7 ft	X	X	X

Main boom	Main boom extension 0° / 20° / 40°			
		11,000 lb	17,600 lb	39,700 lb
151.3 ft	30.2 ft	-	X	X
	57.7 ft	-	X	X
164.0 ft	30.2 ft	-	X	X
	57.7 ft	-	X	X

The information contained in this brochure merely consists of general descriptions and a broad compilation of performance features which might not apply precisely as described under specific application conditions or which may change as a result of further product development. The desired performance features only become binding once expressly agreed in the final contract.

Note: Data published herein is intended as a guide only and shall not be construed to warrant applicability for lifting purposes. Crane operation is subject to the computer charts and operation manual both supplied with the crane.

Subject to change without notice.

10 / 06

**Terex Cranes Wilmington Operations**

Mobile hydraulic and lattice-boom cranes  
202 Raleigh St. · Wilmington, NC 28412 USA  
Phone +1 910 395 8500 · Fax +1 910 395 8538  
Email: american@american-crane.com