

NATIONAL SERIES 1200

Truck-Mounted Telescoping Crane and Accessories

Maximum Vertical Reach: 150 Feet (46.7 Meters)
Maximum Capacity at 10-Foot Radius: 35,000 Pounds (15.9 Metric Tons)

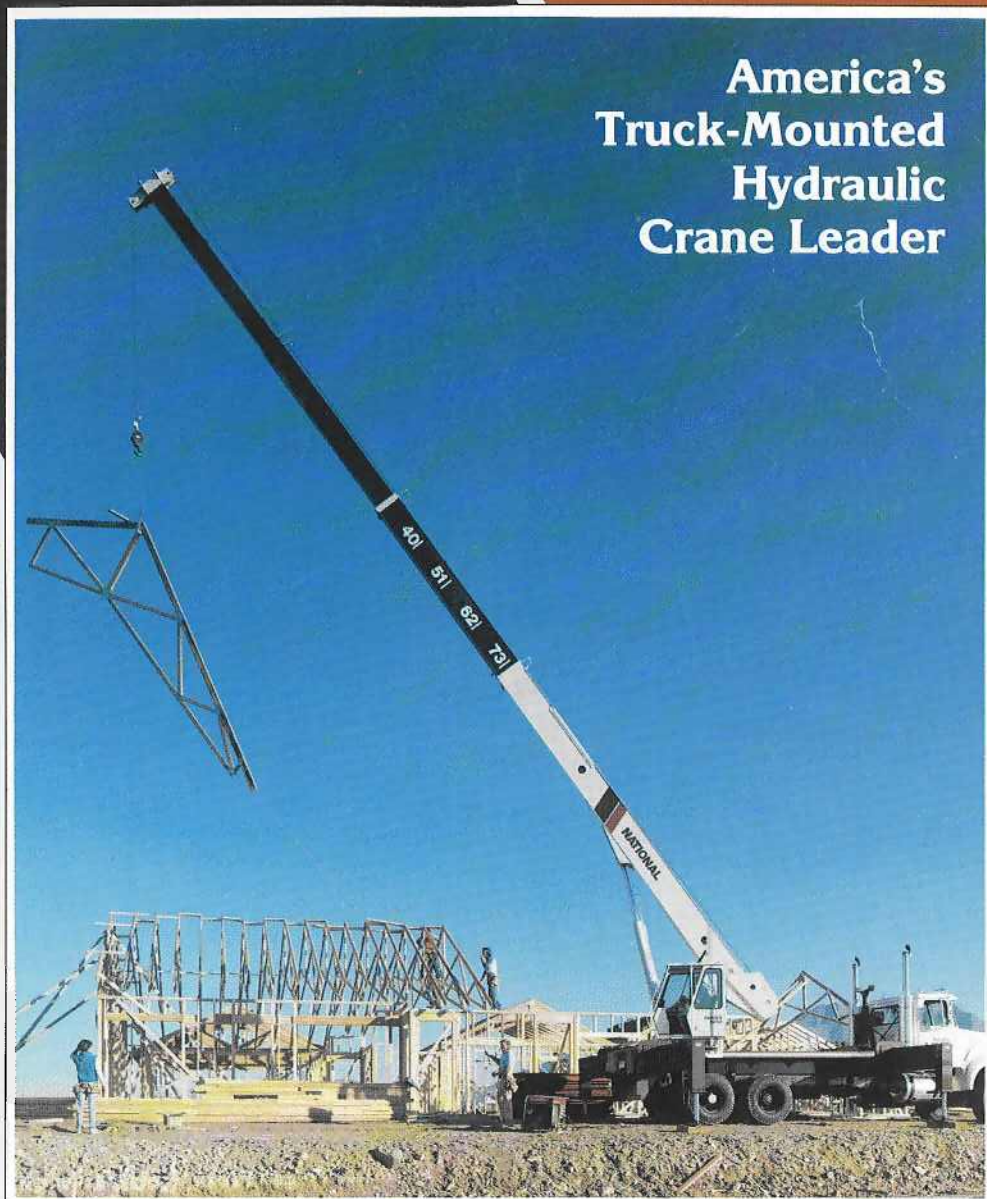

NATIONAL SERIES 1200

National Crane, America's leading manufacturer of commercial truck-mounted telescoping and articulating cranes, has achieved another industry first! Our all new Series 1200 telescoping crane provides an unprecedented vertical reach of 150 feet! This tough and durable, extra-heavy duty crane is engineered, manufactured and fully tested in compliance with National's traditionally rigid standards. Our commitment to quality and our determination to remain on the leading edge of truck-mounted crane technology is evident in virtually every aspect of this new machine. Consider these Series 1200 features:

- 150-foot vertical reach (with the 29- to 52-foot swing-around, manual pullout jib)
- 100-foot fully hydraulic vertical reach with the standard four-section boom
- 17½-ton rated capacity at a 10-foot boom radius
- Proportional boom design allowing higher lifting capacities in normal operating areas
- National's industry-acclaimed box-section boom construction
- Large bolt-in wear pads in boom that last longer and are easier to replace
- Two sets of hydraulic cross-frame outriggers, each with an 18½-foot span
- Standard operator's cabin that rotates with boom movement
- Single-station control console with extra-fine metering and low spool forces, directly coupled with adjustable levers for precise control of crane functions
- Control rods supported by nylon bearings, promoting smooth operation and serviceability
- Horn, start/stop switches, pressure gauge monitoring all functions, and foot and hand control throttle are located at the control station
- Standard three-pump system isolates the winch and rotation functions from other crane functions to provide independent operation capability
- Telescopic angle indicator located for easy operator visibility
- Planetary rotation gearbox with a hydraulic release brake and a slip-through feature that helps protect the rotation system against damage from accidental side loading
- An all new standard high performance planetary winch with roller bearings throughout and highly efficient, axial piston motor to provide the smoothest and fastest winch operation National has ever offered
- One-, two- and three-part load block standard
- Sheave case rigged with two sheaves on top and three underneath for easy multiple-part reeving and to accommodate the optional auxiliary winch
- Optional auxiliary planetary winch for use in picking lighter loads at higher speed when the standard winch is rigged for heavy-load lifting at slower speeds with multi-part reeving
- Boom pivot and hoist cylinder bearings that provide longer life and lower maintenance
- Oil filter and control valves located externally for convenient serviceability
- Mounting on standard commercially available tandem rear axle trucks (refer to truck specifications on page 11)
- Installation on a high-power commercial chassis provides unparalleled mobility



- Mounting: subbase supplied to eliminate truck reinforcing and, in some cases, counterweight (many diesel engine trucks require no counterweight)
- Standard horizontal, behind-the-cab boom rest reduces stress on the crane-frame and protects the crane from transit damage
- 100 gallon oil reservoir with dual spin-on return line filters, dirty filter indicator, oil level and temperature gauge, magnetic plug, clean-out, three suction strainers, and diffuser
- Custom-built three-piece bed to provide maximum flat payload area and operator mobility
- Rear bumper complies to recommended DOT underide protection

Longest reach in the Truck-Mounted Hydraulic Crane Industry!



National's anti two block system is standard on all National cranes (as of June 1, 1986). Photos in this brochure taken prior to that date may not show the crane equipped with the current standard anti two block protection system.

National Series 1200

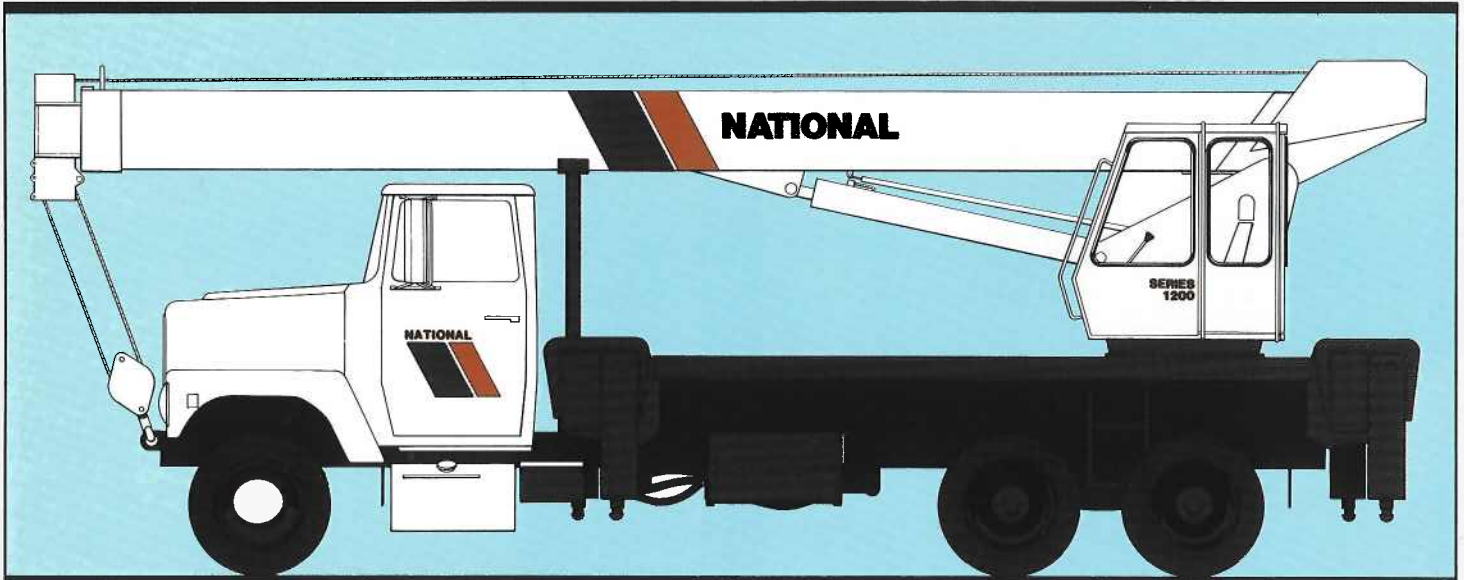

Strong Four-Plate Boom

Through computer aided design, National has removed weight from the Series 1200 boom sections. We fabricate our telescoping boom sections from four high-strength steel members welded with perpendicular corners. This box-section construction lets us use thicker top and bottom plates for extra strength. The use of thinner side plates means increased capacity through lower boom weight. Only strong, low alloy steel is used in National booms. It is welded with automatic, low-hydrogen techniques for extra strong seams. Corner seams are ultrasonically tested for proper penetration.

The National Series 1200 is equipped on all sides with large nylon wear pads impregnated with lubricants which provide a smooth, long-life operation. The wear resistance of the material used in the Series 1200 pads is unexcelled by competitive models.

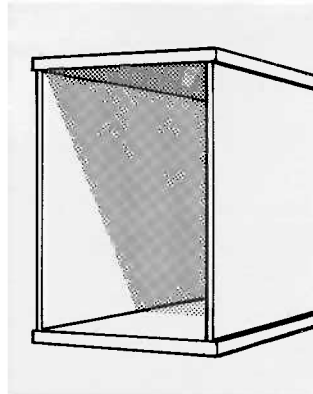

Standard Commercial Truck Mounting

The Series 1200 mounts on standard, commercially available tandem rear axle trucks, yet it meets DOT and stability standards with ease. The crane, not the truck, takes most of the stress. That's the kind of engineering that adds up to lower investment and longer truck life. Procedures allow for the crane to be easily mounted. A subbase is supplied to eliminate truck reinforcing and, in most cases, counterweight (many diesel engine trucks require no counterweight). Installation on a high-power commercial chassis provides unparalleled mobility.

Proportional Extension

Proportional boom design (each boom section extends proportionally at the same time) allows higher lifting capacities in normal operating areas. Proportional boom design is typically found in much larger cranes.



High Performance Planetary Winch

Every Series 1200 comes standard with a high performance planetary gear winch with roller bearings throughout and highly efficient, axial piston motor to provide the smoothest and fastest winch operation National has ever offered. This two-speed winch is filled with our largest diameter cable—9/16". See the winch data chart on page ten for further information.



Multiple Part Reeving

The Series 1200 sheave case is rigged with two sheaves on top and three underneath for easy multiple part reeving and to accommodate the optional auxiliary winch. One, two, and three part load blocks are standard. Four and five part load blocks, for greater lifting capacities while using the winch, are optional.

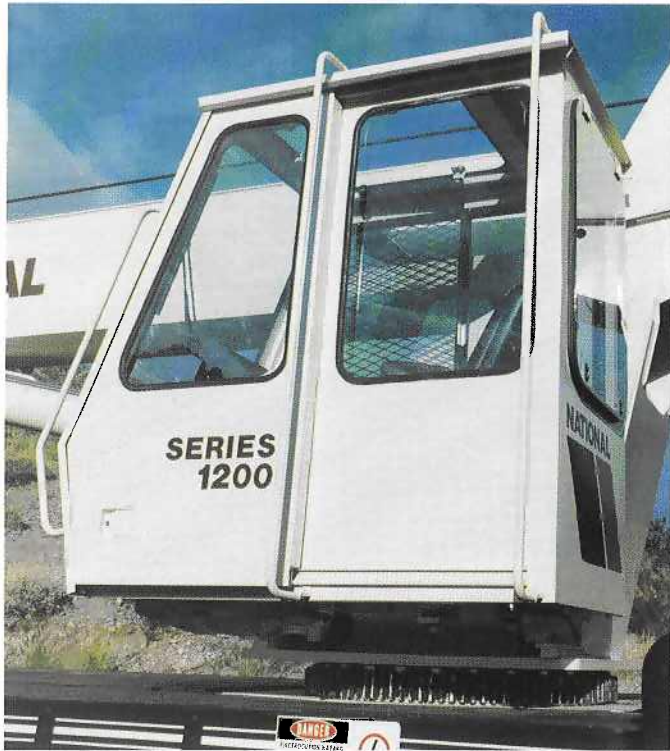

Operator's Cabin

A deluxe, spacious, well-ventilated operator's cabin that rotates with horizontal boom movement is standard on the Series 1200. The cabin design provides for constant forward vision of the boom hook and load. It features safety-glass windows on all four sides of the cab and an impact-resistant, durable Lexan window above the cab for excellent upward visibility.

The Lexan top lifts up for ventilation. Other features include a sliding door, front windshield wiper, dome light, circulation fan, optional heater and defroster system, and a cushioned adjustable seat that can be easily positioned for comfort.

The cabin houses the control console, the horn, start/stop switches, a pressure gauge monitoring all functions, and foot and hand control throttles.

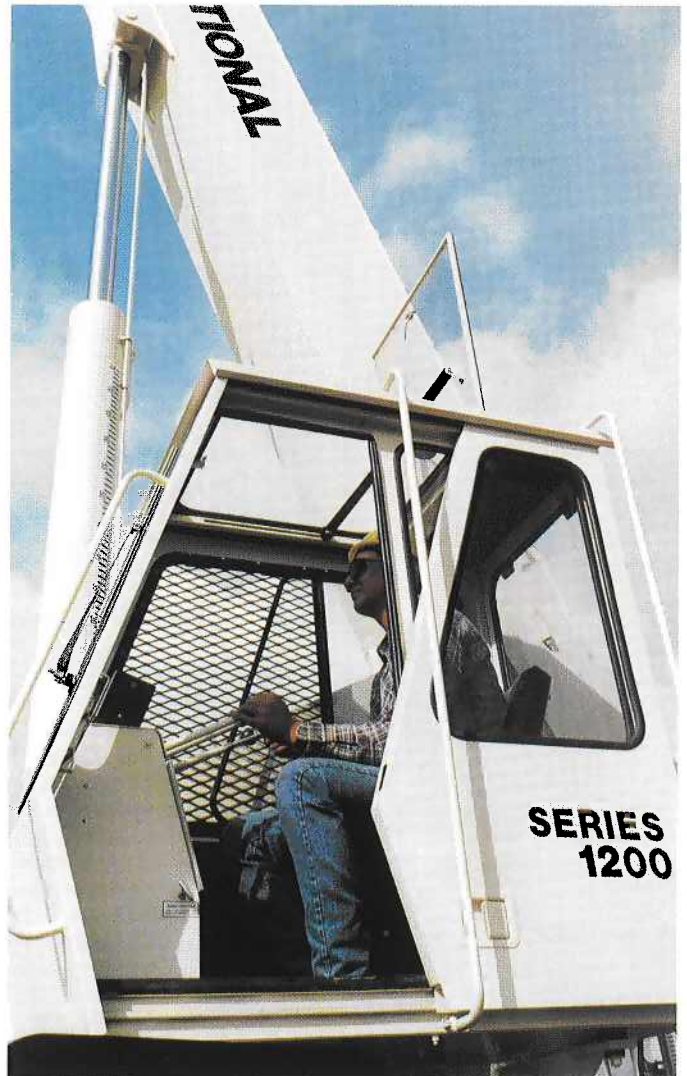

National Series 1200

Precise Controls

The Series 1200 is equipped with a single station control console. Extra-fine metering and low spool forces coupled with adjustable levers provide smooth, precise, fingertip control of crane functions and foot control of telescope functions. Control rods are supported by nylon bearings, promoting smooth operation and serviceability. A horn, start/stop switches, a pressure gauge monitoring all functions and a foot and hand control throttle are located at the control station in the operator's cabin. Outtrigger controls are located at the rear of the crane.



Easy Service, Low Downtime

The Series 1200 is designed with boom access holes for serviceability. Valves are positioned for convenient accessibility and servicing. Oil filters and reservoir are located externally to enhance maintenance.



Positive Planetary Turret Rotation

The planetary rotation gearbox with a hydraulic release brake allows the gearbox to back drive whenever excessive side load is applied to the boom, reducing shock loads on the upper and lower crane structure and gearbox. The gearbox and rotation bearing mounting surfaces are precision machined after welding. This ensures consistent tooth alignment for smooth rotation and low wear, even under maximum loads. The entire turret glides smoothly on a low inertia ball bearing race. Standard rotation is 375° noncontinuous.

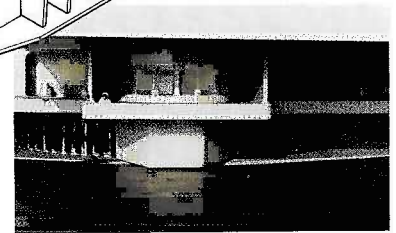
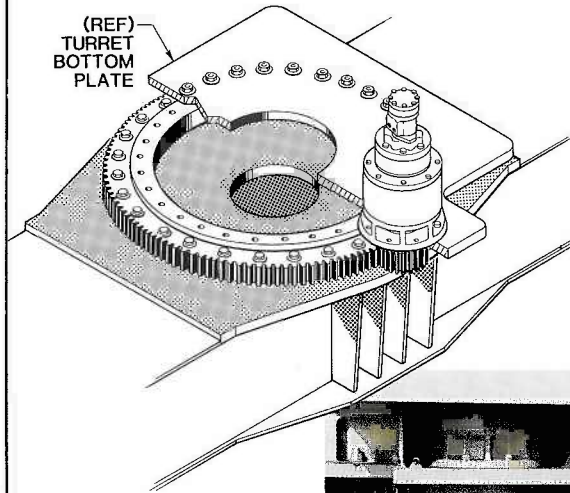

Wide Stance

The Series 1200 is equipped with two sets of hydraulic, out-and-down, cross-frame outriggers. Each has a wide 18½ foot (5.64m) span, affording solid stability. The outriggers retract smoothly, without binding under load. Outrigger controls are located at the rear of the crane. A precision-mounted level indicator aids the operator in leveling the unit during the set-up procedure.

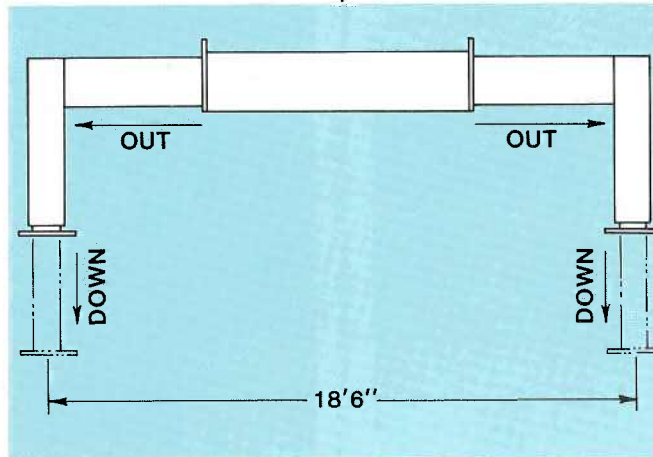

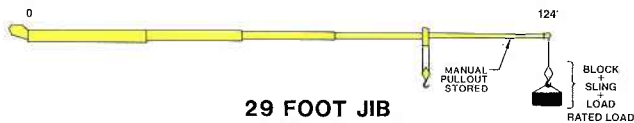
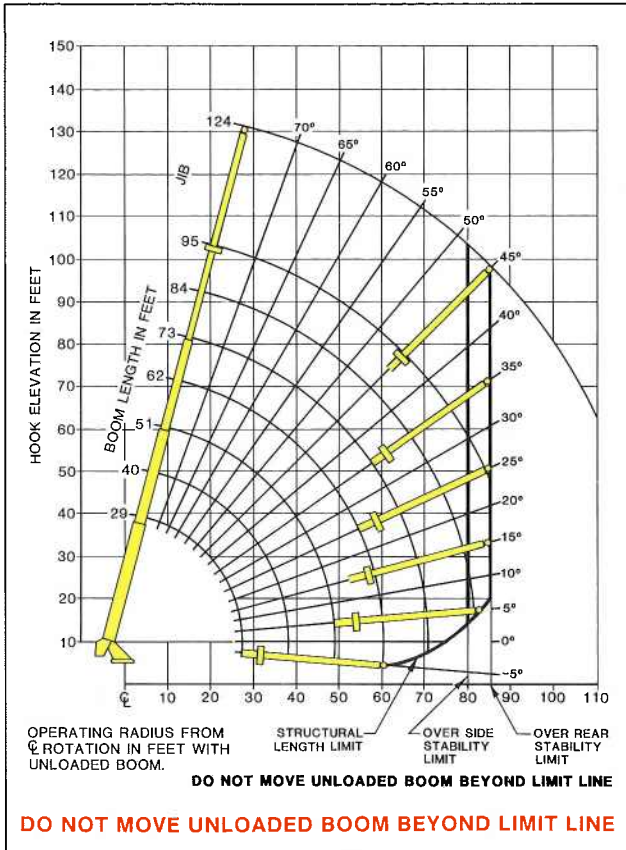

LOAD RADIUS (FEET)	LOADED BOOM ANGLE (DEGREES)	OVER SIDE (lb)	OVER REAR (lb)
36	74°	5200	5200
44	70°	4200	4200
54	65°	3250	3550
64	60°	1950	2300
72	55°	1200	1550
80	50°		1000

SHADED AREAS ARE STABILITY LIMITED CAPACITIES

Capacities shown are with 400-pound block rigged on main boom. If 200-pound block is rigged on main boom, add 150 pounds to capacities shown. If no block is rigged on main boom, add 300 pounds to capacities shown.

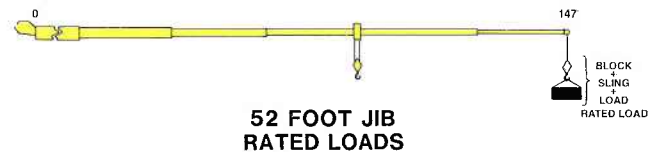
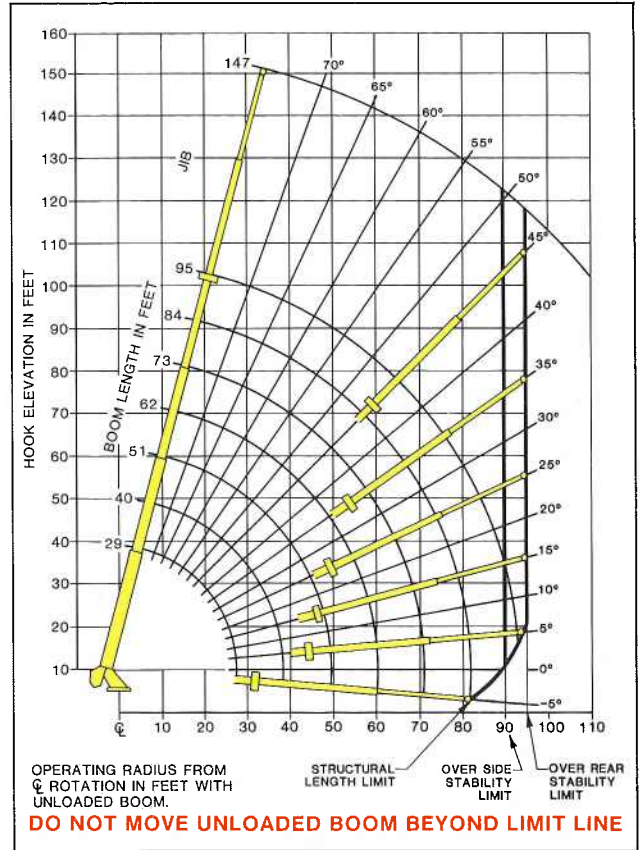

LOAD RADIUS (FEET)	LOADED BOOM ANGLE (DEGREES)	OVER SIDE (lb)	OVER REAR (lb)
44	74°	2800	2800
54	70°	2400	2400
66	65°	2000	2000
78	60°	1400	1600
88	55°	800	1100

SHADED AREAS ARE STABILITY LIMITED CAPACITIES

Capacities shown are with 400-pound block rigged on main boom. If 200-pound block is rigged on main boom, add 100 pounds to capacities shown. If no block is rigged on main boom, add 200 pounds to capacities shown.

Set-up:

1. Fully extend outriggers and level crane.
2. Rig jib as shown in the operator's manual.

Operation:

1. Operate with jib by radius, when main boom is fully extended. If necessary, increase boom angle to maintain loaded radius.
2. Operate with jib by boom angle when main boom is not fully extended. Do not exceed rated jib capacities at any reduced boom lengths.

3. Do not extend unloaded boom beyond stability limit radii shown on range diagram, as loss of stability may occur rapidly and without warning. A 400-pound main block and 150-pound downhaul weight have been considered.
4. All jib loads must be lifted with single part reeving.

National Series 1200 Jib and Winch Data



The sequence of photos above shows how the National 1200 29-52 foot jib folds out into a working position.

NATIONAL SERIES 1200 WINCH DATA			1 Part Line	2 Part Line	3 Part Line	4 Part Line*	5 Part Line*
⚠ WARNING							
<ul style="list-style-type: none"> Do not deadhead lineblock against boom tip when extending boom. Keep at least three wraps of load line on drum at all times. Use only the specified cable on this machine. 							
Winch	Cable Supplied	Average Breaking Strength	High Speed and Low Pull				
			1 Part	2 Part	3 Part	4 Part	5 Part
Standard Planetary Winch & Auxiliary Winch	9/16" diam. 19 x 7 IWRC (Rotation Resistant)	35,000 lbs.	350 fpm 4,100 lbs.	175 fpm 8,200 lbs.	117 fpm 12,300 lbs.	88 fpm 16,400 lbs.	70 fpm 20,500 lbs.
			Low Speed and High Pull				
			1 Part	2 Part	3 Part	4 Part	5 Part
			200 fpm 7,000 lbs.	100 fpm 14,000 lbs.	67 fpm 21,000 lbs.	50 fpm 28,000 lbs.	40 fpm 35,000 lbs.

All winch pulls and speeds are shown on the fourth layer. Winch pulls would increase on the first, second and third layers. Winch line speeds would decrease on the first, second and third layers. Winch line pulls may be limited by the winch capacity or the ANSI 5 to 1 cable safety factor. These are shown below:

Winch	Bare Drum Pull	Allowable Cable Pull
Standard planetary	5,270 pounds (high speed) 9,000 pounds (low speed)	7,000 pounds

*Four and five part load blocks are optional (see page 13).

National Series 1200 Truck Specifications



The complete Series 1200 unit must be installed on the truck in accordance with factory requirements and a test performed to determine actual stability and counterweight requirements since individual truck chassis vary.

Gross Axle Weight Rating (GAWR),
 Front 18,000 pounds
 Gross Axle Weight Rating (GAWR),
 Rear 34,000 pounds
 Wheelbase (WB) 234 inches
 Cab to axle/trunnion (free of obstructions, full width in crane mounting area)
 (CA/CT) 156 inches
 Frame Section Modulus (SM) front axle to rear axle
 50,000 PSI 25 inch³
 or
 100,000 PSI 15 inch³
 Estimated bare chassis weight required for stability prior to installation of crane or accessories
 Front 8,000 pounds
 Rear 7,500 pounds
 Estimated Final Average Weight 45,000 pounds

NOTES:

- (1) Maximum front and rear axle weights vary from state to state. Contact factory for details.
- (2) GAWR means Gross Axle Weight Rating and is dependent on all components of the vehicle such as axles, tires, springs, frame, etc., meeting manufacturer's recommendation. **Always specify GAWR when purchasing trucks.**
- (3) Minimum axle requirements may increase if more payload carrying capabilities are required and local regulations allow.
- (4) Diesel engines require variable speed governor and energize-to-run fuel solenoid for smooth crane operation.

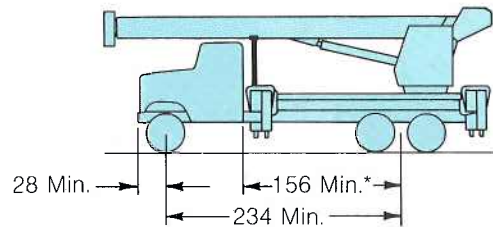

*Clear of obstructions (mufflers, exhaust stacks, etc.) on top of truck frame for full 8-foot width.

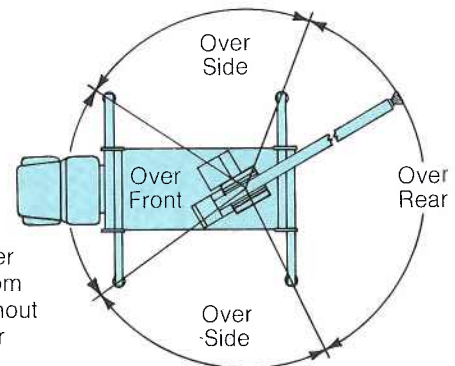

Do not lift over front with boom extended without front stabilizer option.

National Series 1200 Accessories

The Series 1200 is part of the National Lifting System. You can add to your crane's versatility with National accessories. Weights of all accessories attached to the boom or loadline of the crane must be deducted from the effective lifting capacity. Consult your National dealer for specific accessory availability. Some accessories cannot be used in combination with other accessories or the optional jib.

Pallet Fork

Turns your Series 1200 into a versatile, payload-packing fork lift. Great for delivering palletted material right where you want it. 4,400 lbs. (1,814kg) capacity with adjustable throat and teeth. Handles most loads with ease.

Capacity:	4,400 lbs. at 20" center
Throat Opening: (adjustable)	41" to 65"
Tooth Length:	38"
Tooth Width: (outside to outside)	33.5" to 57" min. max.
Weight:	350 lbs.

Model MKF

(Manual leveling, adjustable throat)

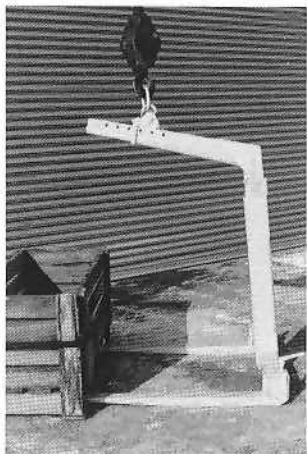

Loose Material Clam Bucket

Increase the flexibility of your National crane with a National clam bucket. Use this versatile accessory to load or move up to ½ cubic yard of loose materials with each bite. Hooks easily to loadline, comes with hydraulic hose on automatic reel and quick-connecting fittings. Extension hoses are required for use with jibs. Just position the load where you want it and open the bucket.

Model LMC



Front Stabilizer

An optional single leg, center-mounted front stabilizer is available for 360° working ranges.

Caution

Do not operate crane booms, jib extensions, any accessories, or loads within 10 feet (3m) of live power lines. Do not exceed jib capacities at any reduced boom lengths.

Hydraulic Oil Cooler

Automatic hydraulic device designed to cool the oil under continuous operation.

Model HOC

Anti Two Block

Two blocking occurs when the winch cable and attachments contact the underside of the boom sheave case, whether by winching up or extending the boom without paying out the winch cable. When this happens, the winch cable can be damaged by crimping or over tensioning. The anti two block option prevents cable damage by sensing the position of the winch cable end attachments with respect to the sheave case and shutting down the functions that can cause two blocking.

Model ATB

(available with standard or auxiliary winch)

Model ATBJ

(for use with jibs only)

Auxiliary Winch

An auxiliary high-performance planetary winch may be used to pick lighter loads at higher speeds when the standard winch is rigged for heavy-load lifting at slower speeds with multi-part reeving. This winch, like our standard winch, is filled with 9/16" diameter cable. See the winch data chart on page ten for further information.

Boom Length Indicator

This electronic device indicates the boom length on a display panel. Contact the factory for availability and additional information.

Glide Swing

The glide swing option allows the crane operator to manually apply a swing brake. When swinging the turret/boom, he can coast the unit to a stop. Contact the factory for availability and additional information.

Positive Swing Lock

This one-position mechanical locking method prevents the rotation of the turret/boom when the crane is stowed for transit.

Four and Five Part Load Blocks

These optional load blocks provide greater lifting capacities while using the winch. See winch data chart on page ten.

Continuous Rotation

This hydraulic and electrical swivel allows a continuous rotational movement of the turret for convenient load positioning. It is available only on a standard crane with no hydraulic or electronic options.

National Warranty, Parts and Service

The National Warranty

No product is better than its warranty. And no warranty is better than the company behind it.

We didn't get to be America's leading manufacturer of truck-mounted telescoping and articulating cranes by building less than the best. Or backing our products with less than a comprehensive warranty.

Our warranty covers your crane against defects in materials or workmanship for **six full months** from the date of shipment, subject to the conditions of the warranty.

When you select a National crane, you're getting more than just a crane. You're getting a nationwide dealer warranty service network, strong warranty protection and our special concern for every product we make.

Read our warranty. Then, don't settle for less. For complete information, write National Warranty Service, Waverly, NE 68462.

The National Parts System

Authorized National Crane dealers maintain a parts supply to support the National cranes in each dealer's area. If a dealer cannot immediately supply a needed part, the factory can normally provide the part to the dealer within 48 hours on request. National's responsiveness to dealer requests means that your crane will be back on the job fast. National maintains a highly trained Service and Parts staff to answer dealer service questions and expedite parts shipping.

The National Service Center

Just west of Lincoln, Nebraska, we maintain a well-equipped service center. Here, we do all our factory crane mounting.

The central location of our Lincoln Service Center makes it easy to return cranes for special modifications or extreme repairs. Most National dealers can perform all but the most unusual modifications or most serious repairs.

Should you need to return your crane to us for modification, warranty repair or other service, we will give it priority care and see it's returned as soon as possible.

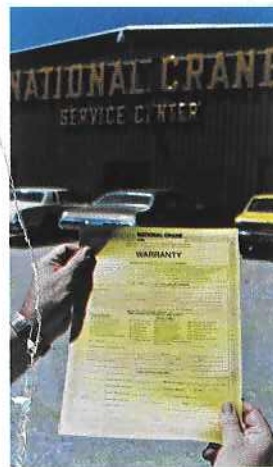

National Series 1200 Specifications

General Construction

Low alloy, high strength steel including T-1, Exten, Stress Proof and other steels combined with special low hydrogen welding techniques wherever advantageous. Standard color: National Ivory and Brown.

Subbase/Frame

Box construction, torsion resisting sub-base integral with front and rear outrigger boxes. Sub-base is attached to truck frame and bed by bolt on attachment brackets. Rotation bearing and level indicator surfaces are precision machined after welding to ensure accurate alignment and flat surfaces for prolonged life.

Turret

Fabricated rigid structure well braced for stability. Bearing surface, rotation gearbox mounting and pivot pins are machined after welding to insure accurate alignment and flat surfaces for prolonged life.

Rotation

375 degree non-continuous rotation. Rotation force 518,000 in-lbs (1,564,000 in-lb breaking strength). Turret rotation is powered by a hydraulic orbit motor and planetary gearbox driving a pinion. The turret rotates on a ball bearing race. A spring applied hydraulic release brake provides positive no drift lateral positioning.

Outriggers

Front and rear outriggers are beam and box style out-and-down with an 18'6" span (center of pad at ground level). Outriggers are individually controlled from rear of unit and will not bind when raising or lowering truck. They can be positioned up to 11" below ground level when mounted on a truck with a frame height of 38". Outrigger pads are removable, 22" diameter and are stored underneath truck bed. Vertical outrigger cylinders are equipped with butt mounted safety check valves.

Lift Cylinders

Double acting hydraulic cylinder raises and lowers the boom. Butt mounted safety holding valve prevents the boom from falling in the event of a hose failure. Tough field tested bearings in lift cylinder and boom pivot combined with micro honed pins provide long life with reduced maintenance.

Boom

Boxed construction sections telescope proportionally through use of a double acting hydraulic cylinder with proportioning cables. Internal cable sheaves use maintenance-free, self-lubricating bearings. Boom wear pads are nylon plates impregnated with molybdenum disulfide on all sides of the boom permitting maximum loads to be extended at greater radii. Holding valve prevents retraction except under power.

Controls

Single operator station mounted to turret provides excellent load visibility at all times. Telescopic control levers with adjustable padded seat for operator comfort. Operator platform is mounted on isolation mounts for noise and vibration control. Foot control on telescope function is standard. Simultaneous operation of loadline, boom functions and swing are standard. Horn, stop/start switch and pressure gauge are located at the control console for convenience. Covers are easily removable for maintenance.

Winch

Hydraulic axial piston motor with planetary gearbox, brake and counterbalance valve for power down load lowering. 7,000-pound single line pull available with 325 feet of rotation resistant 9/16" diameter, 35,000 pound breaking strength loadline. Standard two speed winch option provides continuous duty high and low speed winch operation. An auxiliary winch is available with the same performance specifications.

Pump

One high pressure, high speed gear type three section pump independently providing 35 gpm to winch, 35 gpm to crane and 15 gpm to swing for smooth fast simultaneous operation. Pump is bi-directional for convenient installation and hookup.

Cylinders

Shaft packing polyurethane U-cup type shafts, high yield stress relief chrome plated. Piston seals polyurethane U-cup and rider construction. Cylinder barrels microhoned tubing, butt mounted safety check valves.

Valves

Four way, spring centered, spool type, with independent relief valves set at 2650 psi on all circuits to protect circuits against overload.

Hose

All high pressure hose is wire braid reinforced having a minimum safety factor of 4 to 1.

Operating Speeds

Winch fourth layer high speed: 350 fpm; winch fourth layer low speed: 200 fpm. Rotation 375°: 35 seconds. Boom up (-5° to 75°): 24 seconds. Boom down (75° to -5°): 24 seconds. Boom extend (29 feet to 95 feet): 90 seconds. Boom retract (95 feet to 29 feet): 60 seconds. (Speeds above assume no load on boom with 35 gpm oil flow on boom and winch, and 15 gpm oil flow on rotation.)

Oil Tank Capacities

100-gallon supply tank normally mounted on sub-frame. Sight gauge, breather, suction strainer, clean out, magnetic plug and thermometer.

Filter

10 micron, replaceable cartridge return line filter. 100% filtration with change indicator gauge.

Operator's Cab

Totally enclosed operator's cab complete with locks on door. Opening top, side and rear windows. Safety glass side windows with Lexan, impact resistant top window. Wind shield wiper, dome light and sound insulation are standard. Cab is isolation mounted for operator comfort.

Capacity Alert Systems

Devices are available to reduce the possibility of operator error. Contact your dealer for information and availability.

