

SIMON AERIALS INC.
10600 W. Brown Deer Road
Milwaukee, Wisconsin 53224
Phone (414) 355-0802
TWX: 910-262-3310
FAX: (414) 355-0832
Cable: SIMON MIL

MODEL
32/21
Electric
&
Gas

PART NO. 89-411002

SIMON

OPERATOR'S MANUAL

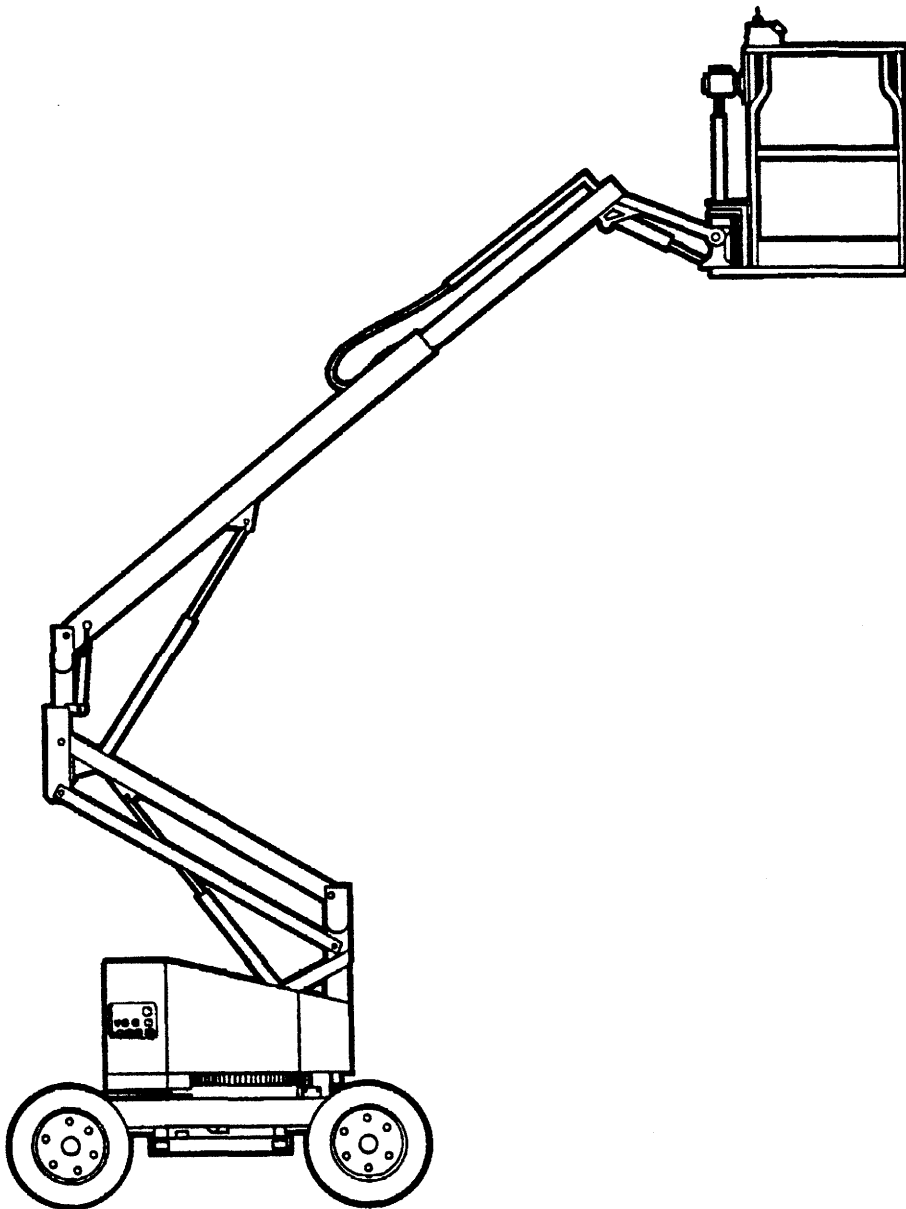

This Operator's Manual should be read prior to the safe operation of the self-propelled Simon-Eagle units.

CALIFORNIA

Proposition 65 Warning

Engine exhaust contains chemicals known to the State of California to cause cancer, birth defects, and other reproductive harm.

C O N T E N T S

DIMENSIONAL DATA & SPECIFICATIONS
PRIMARY MACHINE COMPONENTS
SAFETY RULES & PRECAUTIONS
DAILY OPERATIONAL CHECKLIST
FUNCTION OPERATION DESCRIPTIONS
GROUND CONTROLS FEATURES & OPERATIONAL CHECKS
BASKET CONTROLS FEATURES & OPERATIONAL CHECKS
EMERGENCY SYSTEM & PROCEDURES
OPERATOR TROUBLE SHOOTING
PRE-DELIVERY INSPECTION & CHECKLIST
WARRANTY

LOADING INSTRUCTIONS

When loading the Simon Eagle, drive the unit onto the truck/trailer with chassis first and the basket last. Care should be taken to insure that the motor guard plate located under the chassis is not damaged while loading/unloading the unit onto the truck/trailer.

SPECIFICATIONS

-ELECTRIC and GAS VERSIONS-

SIMON-EAGLE 32/21

Working Height	39'/11.89m
Platform Height	32'/9.75m
Horizontal Outreach	21'/6.40m
Platform Capacity (unrestricted)	500#/227kg
Platform Dimensions	30"x60"/.762x1.52
Stowed Length	14'2"/4.32m
Stowed Height	6'7"/2.01m
Width	5'10"/1.78m
Wheelbase	6'3"/1.91m
Outside Turning Radius	12'6"/4.12m
Inside Turning Radius	6'1"/1.85m
Travel Speed-Stowed	3.6mph/5.8kph
Travel Speed-Elevated	0.5mph/0.8kph
Ground Clearance	8½"/0.21m
Gross Weight	9060#/4110kg
Gradeability	14 ⁰ /25%
Basket Rotation	180 ⁰
Tires	7x15-8 ply
Hydraulic Operating Pressure(psi/bars) .	2465#/176kg
Turret Rotation	360 ⁰ non-continuous

SIMON-EAGLE 31/21

Working Height	38'/11.58m
Platform Height	31'/9.45m
Horizontal Outreach	21'/6.40m
Platform Capacity (unrestricted)	300#/136kg
Platform Dimensions	31"x24"/.79x61
Stowed Length	13'/3.96m
Stowed Height	6'7"/2.01m
Width	5'10"/1.78m
Wheelbase	6'3"/1.91m
Outside Turning Radius	13'6"/4.12m
Inside Turning Radius	6'1"/1.85m
Travel Speed-Stowed	3.6mph/5.8kph
Travel Speed-Elevated	0.5mph/0.8kph
Ground Clearance	8½"/0.21m
Gross Weight	6500#/2948kg
Gradeability	14 ⁰ /25%
Tires	7x15-8 ply
Hydraulic Operating Pressure(psi/bars) .	2465/176
Turret Rotation	360 ⁰ non-continuous

PRIMARY MACHINE COMPONENTS

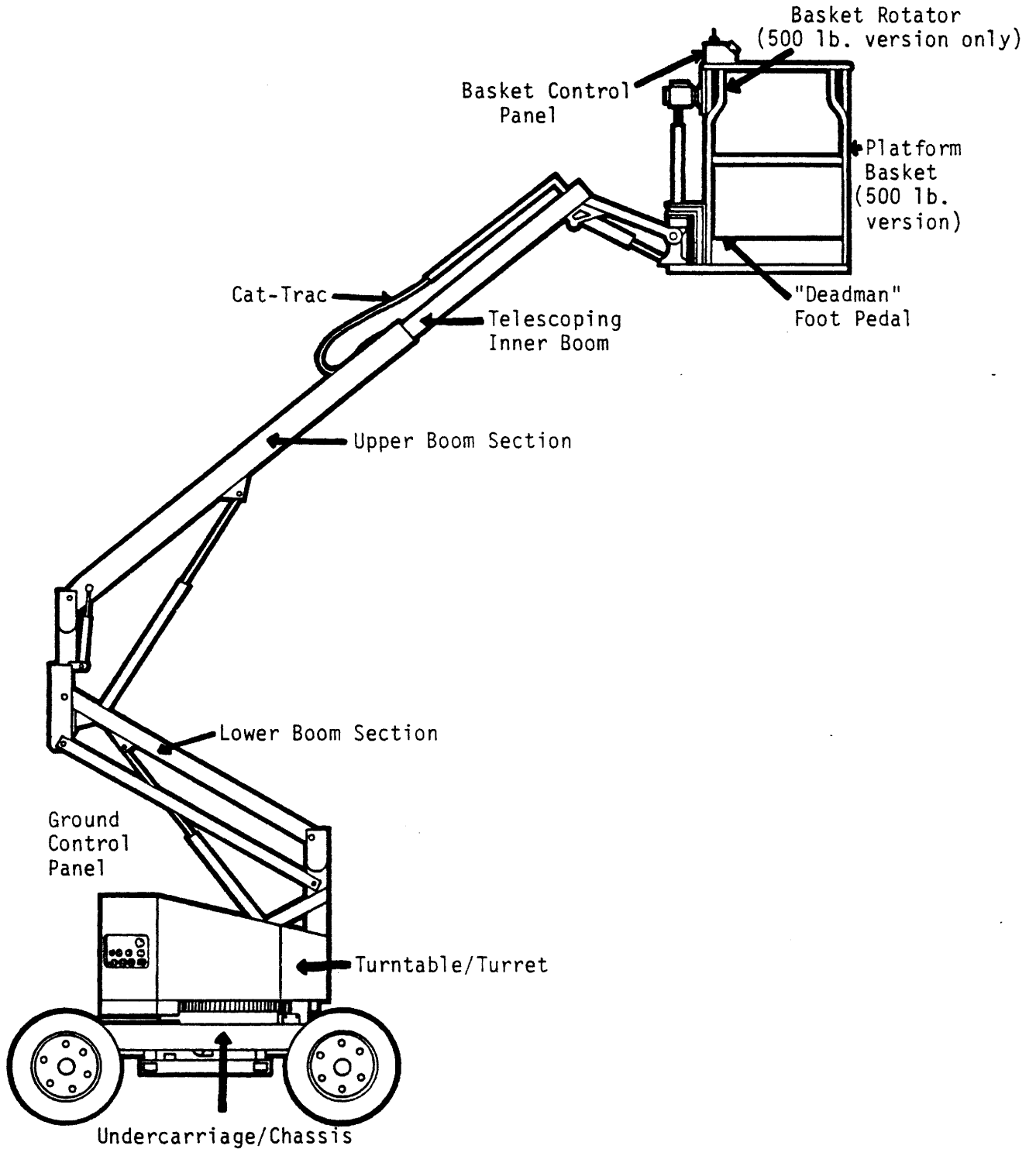

This unit is specifically designed for light industrial and maintenance applications and should be used accordingly.

SAFETY RULES and PRECAUTIONS

IMPORTANT: This manual is designed to point out the Safety Hazards that could affect the safe use and operation of your Simon-Eagle self-propelled unit. Operators should be aware of and comply with all manufacturer's instructions and OSHA/ANSI guidelines regarding safety.

This OPERATOR'S MANUAL should be read prior to the safe operation of your Simon-Eagle aerial platform.

1. Only trained, medically fit personnel should operate the self-propelled Simon-Eagle unit.
2. DO NOT exceed the safe working load of the Eagle Series unit in any configuration. Review this manual's specification data sheet regarding your particular model's capacities and dimensions.
3. DO NOT raise the boom sections unless the Eagle is on a firm, level surface. (Recommended surface level for driving while elevated not to exceed a 1.5 degree slope).
4. DO NOT exceed the maximum basket horizontal pull of 66 lbs.
5. DO NOT alter, modify or disable any safety devices or interlocks.
6. DO NOT use the Eagle as a crane or hoist to lift oversized or hanging loads.
7. DO NOT sit, stand or climb on basket rails.
8. DO NOT use scaffolding, ladders or similar items to extend the Eagle's reach.
9. DO NOT operate the Eagle within 15 feet of high voltage wires. This boom is NOT insulated.
10. DO NOT use the Eagle in electrical storms or in high wind situations.
11. OSHA approved safety belts should be worn at all times when operating the Simon-Eagle unit. Make sure that the entry bar to the basket is secured before operating.
12. Since the machine may be operated from its ground controls, precautions should be taken to prevent unauthorized personnel from operating the work platform.
13. The operator should complete the daily operational checklist found in this manual prior to placing the unit in service.
14. The operator should immediately report any noises, vibrations or malfunctions of the Simon-Eagle to their supervisors.
15. The operator should note that the travel speed automatically decreases when the lower boom is elevated.
16. Fork lift boots located under the unit's chassis are to be used for the transport of the unit only. Do not operate the Simon-Eagle while being transported.

17. The operator shall insure that the area surrounding the work platform is clear of personnel and equipment before driving, raising or lowering the booms.
18. The operator shall maintain a safe distance from overhead and ground obstacles, debris, dropoffs, holes, depressions and other hazards for safe elevated travel.
19. The operator shall limit travel speed according to conditions of the ground surface, congestions, slope, location of personnel or any other factors that could cause hazard of collision or injury to personnel.
20. The operator shall use caution to prevent ropes, electrical cords, hoses etc. from becoming entangled in the unit's boom sections when it is being elevated, lowered, raised or repositioned.

BATTERY-POWERED UNITS:

- . DO NOT operate the Eagle if the batteries are not at a reasonably charged rate or if the unit is sluggish in operation.
- . DO NOT recharge the Eagle batteries near sparks or open flames as batteries emit highly explosive hydrogen gas when being charged.

GAS OR DUAL FUEL UNITS:

- . The operator should check fuel system for leaks or damaged fuel lines before operating unit. If any damage is found, the operator should contact their supervisor immediately.
- . DO NOT refuel the Eagle unit near sparks or open flames. Gasoline vapors and L.P. gas vapors are highly explosive.

"DAILY" OPERATIONAL CHECKLIST

All checks must be completed before operation of the Simon-Eagle unit.

DATE _____ INSPECTED BY _____

MODEL NUMBER _____ SERIAL NUMBER _____

GENERAL INFORMATION

1. Keep inspection records up-to-date.
2. Report all discrepancies to your supervisor.
3. A dirty machine cannot be properly inspected. Clean the unit including the boom cat-trac and the boom sliding areas. Lubricate with WD-40 or equivalent. DO NOT USE GREASE OR GEAR LUBE.

INITIAL

- ___ Check unit for any prior shift or transportation damage, ie. missing parts, torn or loose hoses, hydraulic oil leaks, torn or disconnected wires, flat or damaged tires etc. Hinged doors on both sides can be opened to view inside components.
- ___ Check hydraulic oil level with boom fully lowered and retracted. Oil level should be at the line marked on the sight gauge.
- ___ Check hydraulic pressure to insure correct function speeds.
- ___ Check hoses for signs of external damage.
- ___ Check tires to verify a 65 psi pressure.
- ___ Check tire rim security for lug nut tightness.
- ___ Check all pivot pins to insure good condition and secured positions.
- ___ Check cat-trac on top of boom to verify that it is not bent or sagging.
- ___ Check basket and rails to insure secured platform.
- ___ Check basket leveling system for proper operation.
- ___ Check safety belt connections.
- ___ Check basket controls for proper operation.
- ___ Check deadman pedal in basket for proper operation.
- ___ With the basket raised above horizontal, check for smooth operation with low speed drive.
- ___ Check emergency manual pump for operation.

FOR ELECTRICAL UNITS

- ___ Check battery fluid level and specific gravity. Distilled water should only be added after charging.
- ___ Check battery terminals for tightness of connections and cleanliness.
- ___ Check battery charger to verify that charge is adequate.
- ___ Unplug battery charger before placing Simon-Eagle into operation.

FOR GAS UNITS

- ___ Check fuel level.
- ___ Check engine oil level.
- ___ Check battery fluid level.

If all pre-inspection checks have been completed, the operator is ready to test the self-propelled Simon-Eagle from the ground control panel.

PLATFORM CONTROL PANEL
(ELECTRIC)

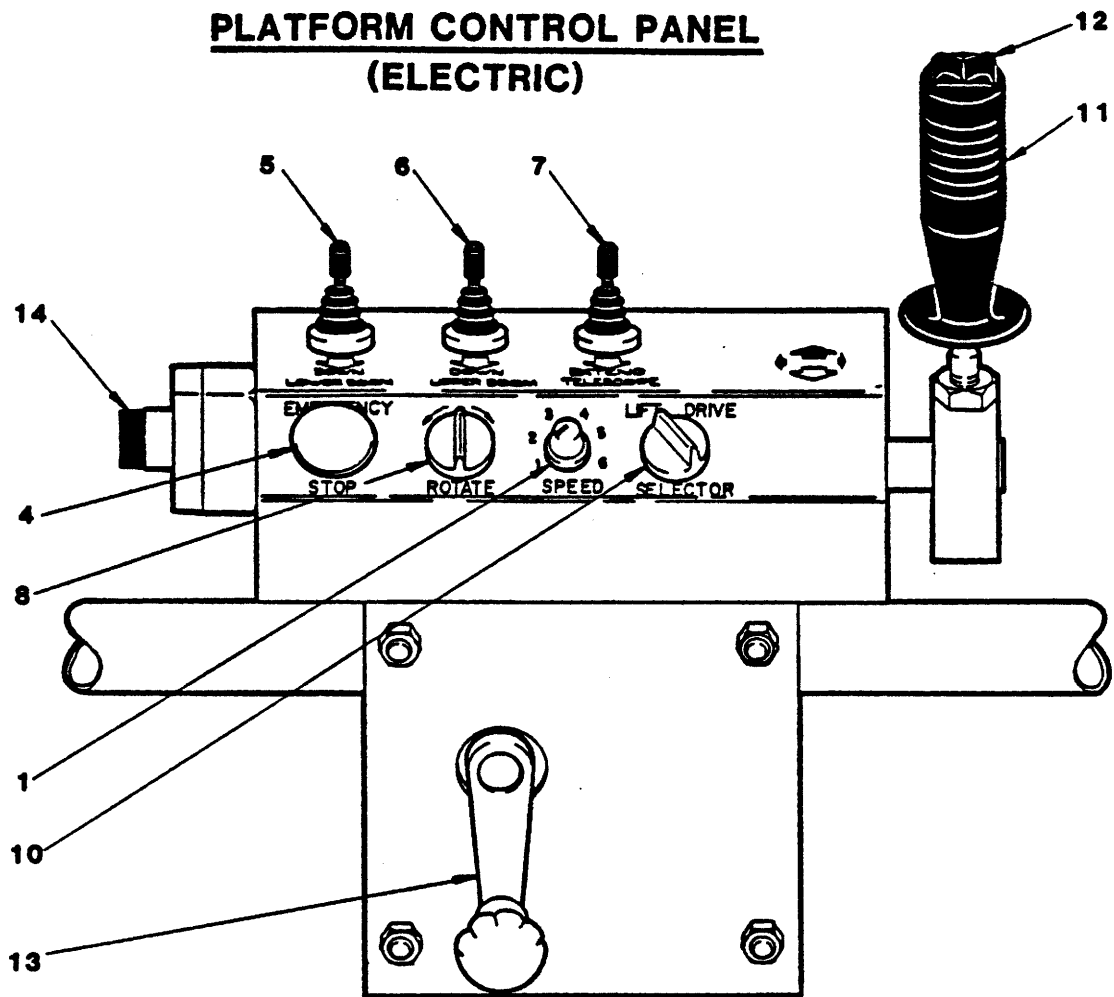

GROUND CONTROL PANEL
(ELECTRIC)

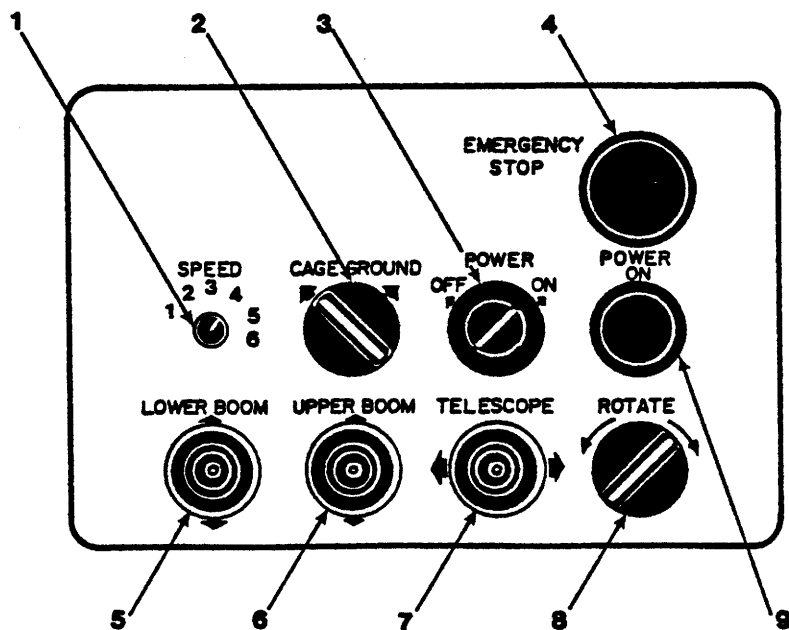

PLATFORM CONTROL PANEL

(GAS)

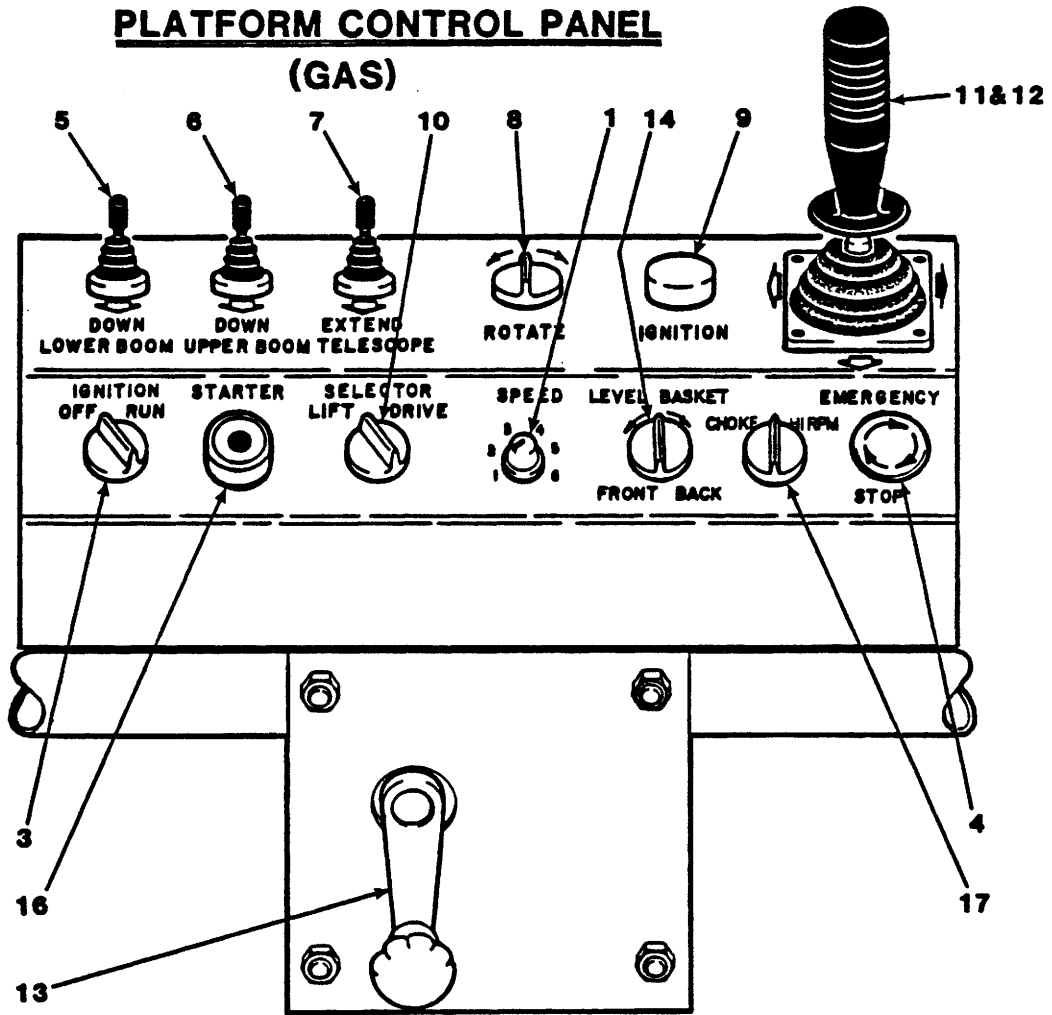

GROUND CONTROL PANEL

(GAS)

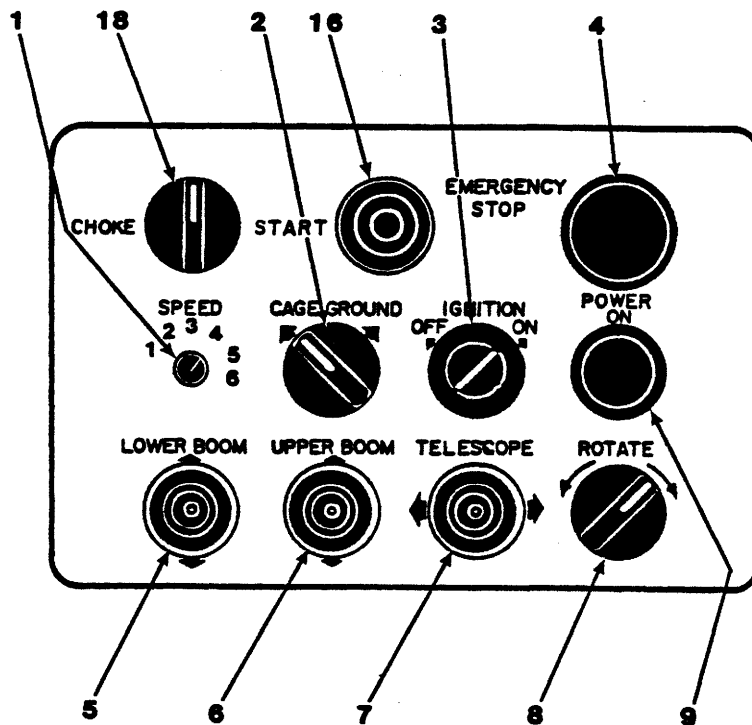

FUNCTION OPERATION DESCRIPTIONS

<u>ITEM NO.</u>	<u>FUNCTION NAME</u>	<u>LOCATION</u>	<u>DESCRIPTION</u>
1.	Speed Control	Platform Basket & Ground Panels	Variable dial selector which allows the operator to vary the speed of the boom lift, telescope or rotate functions when used in conjunction w/the boom lift, rotate and telescope function controls. 0=low speed 6=high speed
2.	Platform Basket/Ground Selector	Ground Panel Only	Transfers all power from ground control panel to the platform basket control panel when switched.
3.	Ignition/Key Switch	Ground Panel Only-Electric Ground & Platform Basket Panels-Gas	Main power shut off. To secure the unit from unauthorized operation, the key may be removed from the ground panel.
4.	Emergency Stop	Ground & Platform Basket Panels	Red selector button used to stop all functions in an emergency situation. To activate, depress the button. To reset, turn the button clockwise.
5.	Lower Boom Lever	Ground & Platform Basket Panels	Selector handle used to raise the lower section. The drive limit switch is activated when this section of boom arms is raised, thus the unit's travel speed automatically decreases.
6.	Upper Boom Lever	Ground & Platform Basket Panels	Selector handle used to raise the upper section. These boom tubes can be raised and lowered separate from the lower arms.
7.	Boom Telescope Selector	Ground & Platform Basket Panels	Selector handle which allows the telescoping inner boom tube to extend and retract to give the operator telescoping access over obstacles.
8.	Rotate Selector	Ground & Platform Basket Panels	Controls the swing function of the turret or superstructure. The turret rotates 360° non-continuous due to the mechanical stops provided on the unit.

<u>ITEM NO.</u>	<u>FUNCTION NAME</u>	<u>LOCATION</u>	<u>DESCRIPTION</u>
9.	Main Power Light	Ground Panel Only-Electric Ground & Platform Basket Panels-Gas	An indication that the unit is activated. If power light is not illuminated, main power is not being supplied to the platform basket or ground controls.
10.	Lift/Drive Selector	Platform Basket Panel Only	Transfers all power from the lift functions to the drive and steer functions when switched.
11.	Drive Controller	Platform Basket Panel Only	Drive handle controls all forward and reverse drive functions at a proportionally controlled speed.
12.	Steer Function	Platform Basket Panel Only	Allows for right and left turns during the drive function.
13.	180 ^o Manual Platform Basket Rotator	Platform Basket Only	Mechanically driven rotator gives 180 ^o platform basket rotation to either side of the boom.
14.	Platform Basket Leveling Switch	Platform Basket Only	Closed loop leveling system allows added leveling to the platform basket, if necessary.
15.	Foot Pedal	Platform Basket Only	Permits operation of all lift and drive functions when pedal is depressed.
16.	Starter Button	Platform Basket Panel Only (Gas Version)	Starts engine from platform basket when key switch is turned on and button is depressed.
17.	Throttle/Choke Switch	Platform Basket Panel Only	Turning the switch left, chokes the engine. Turning the switch right achieves a high rpm speed throttle. Engine idles when switch is centered.
18.	Momentary Choke Switch	Ground Panel only	Activates engine choke from ground panel.

BASKET CONTROL PANEL CHECKS

- . When all operations are functional at the lower control panel, test the basket control functions.
- . Switch the basket/ground selector to the basket mode.
- . Turn emergency stop button clockwise to allow for operation.
- . Set the speed selector at zero and move the lower boom function switch in the direction necessary to raise the lower boom sections.
- . By dialing the desired speed on the speed selector and activating the boom function switches (lower boom - upper boom - telescope - rotate), smooth proportional operation can be achieved.
- . Test the upper boom functions in the same manner as the lower boom function.
- . Extend and retract the tip boom to check the telescope function.
- . Rotate the turntable to check for proper operation.
- . Achieve a proportional driving speed by slowly moving the combination drive/steer controller handle forward or reverse. Allow the controller to feather the desired speed through the proportional controlled drive system.
- . Maximum travel speed is only attained when the lower boom sections are fully lowered and retracted. Travel speed automatically decreases when the lower boom sections are elevated.

- . Braking is attained by releasing the foot pedal located on the basket floor. For a slow speed while descending a ramp, make sure the boom sections are fully lowered and retracted and then gradually move the drive/speed controller in the opposite direction of travel.

NOTE: ALL FUNCTIONS CAN ONLY BE ACTIVATED WHEN THE FOOT PEDAL IS DEPRESSED. THIS ALSO RELEASES THE BRAKE IN THE DRIVE SYSTEM ALLOWING FOR UNIT MOVEMENT. CARE SHOULD BE TAKEN TO SLOWLY RELEASE THE FOOT PEDAL TO AVOID SUDDEN MOVEMENTS.

<u>FOOT PEDAL</u>	<u>SELECTOR</u>	<u>OPERATION</u>
Depressed	Lift	Lift, telescope and rotate works. Brake is on because of selector
	Drive	Lift etc. not possible. Brake released for driving when drive/steer handle is moved.
Released	Lift	Lift, telescope and rotate will not work.
	Drive	Unable to drive unit. Brake remains on.

GROUND OPERATIONAL CHECKS

- Switch basket/ground selector to the ground mode.
- Turn the key switch to activate the unit. The main power light should illuminate.
- If the power light does not illuminate, turn the emergency stop button clockwise at both the basket and ground control panels. When this button is depressed, all functions at ground and basket control panels automatically become inoperative.
- With the power light now illuminated, move the lower boom function switch in the direction necessary to raise the lower boom sections.
- Dial the speed selector from zero to six while raising the lower boom to check for proper operation of the speed selector.
- Listen for noises and vibrations in operation as the boom travels up and down.
- Check the upper boom function in the same manner as the lower boom described above.
- Lower the booms to the stowed position.
- Test the telescope function by extending and retracting the tip boom section by using the speed selector to select the desired speed.
- Rotate the turntable to test for proper operation. Correct any stopping adjustments on the limit switches.

GROUND CONTROL PANEL (ELECTRIC)

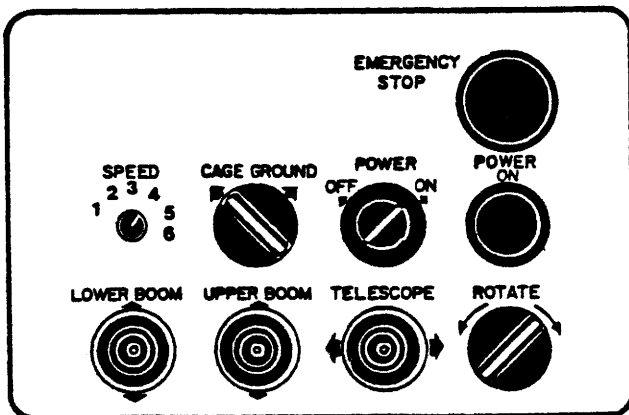

GROUND CONTROL PANEL (GAS)

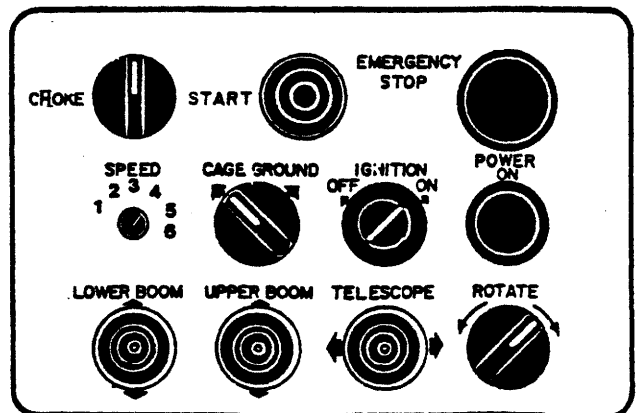

- To steer the unit left or right, operate the rocker switch located on the top of the drive/steer controller of the electric unit. On the gas unit, move the complete drive/steer controller handle in the appropriate direction.
- The platform basket leveling system is a closed loop hydraulic system utilizing both a master and slave cylinder. It becomes necessary to add hydraulic oil periodically to help level the platform basket. This is achieved by using the selector switch located on the side of the platform basket control panel.

IMPORTANT!! DO NOT USE PLATFORM BASKET LEVELING SYSTEM IN CONJUNCTION WITH ANY OTHER FUNCTION.

- 180° platform basket rotation with the 500 lb. Simon-Eagle is possible by utilizing the hand crank located in the center of the platform basket.
- If any noises, vibrations or malfunctions are noted when performing the unit's functions at either the ground or platform basket control panels, contact your nearest Simon-Eagle distributor before placing the unit in operation.

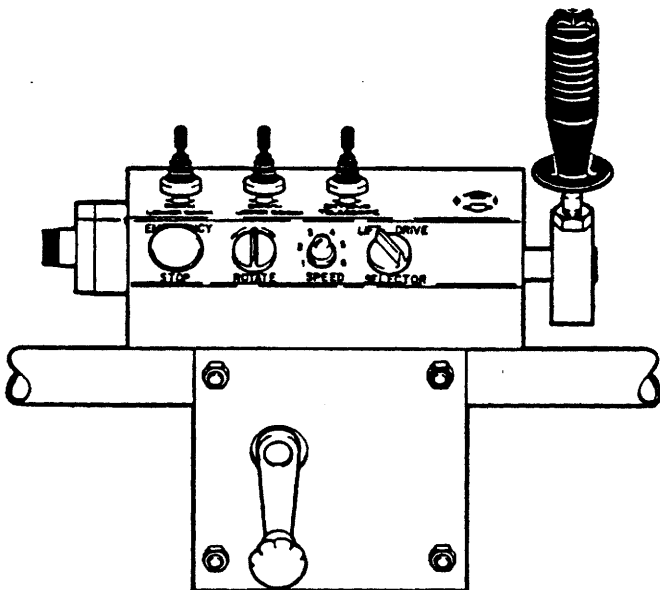

**PLATFORM CONTROL
PANEL - ELECTRIC**

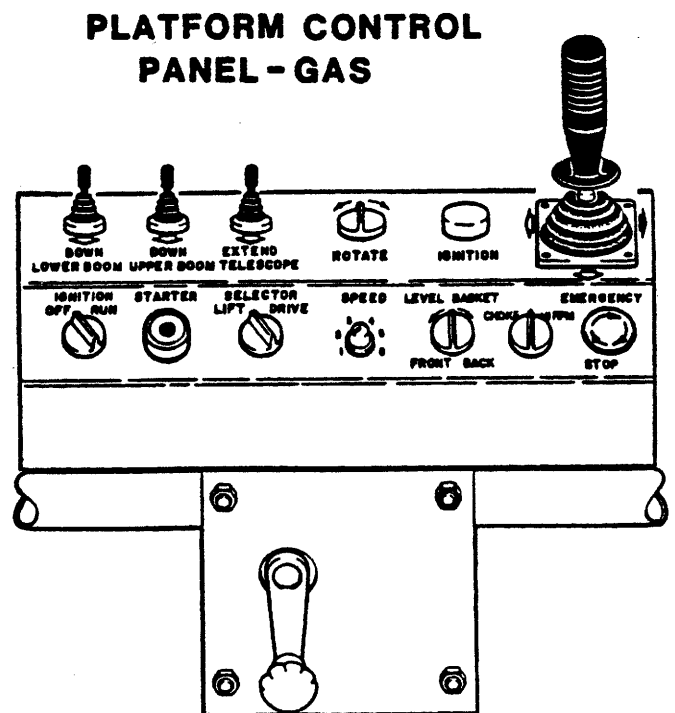

**PLATFORM CONTROL
PANEL - GAS**

EMERGENCY LOWERING VALVES:

Lowering of the lower boom and upper boom sections can also be done by carefully loosening the red knobs located at the base of each lift cylinder. Use care as not to get entangled in the folding structure.

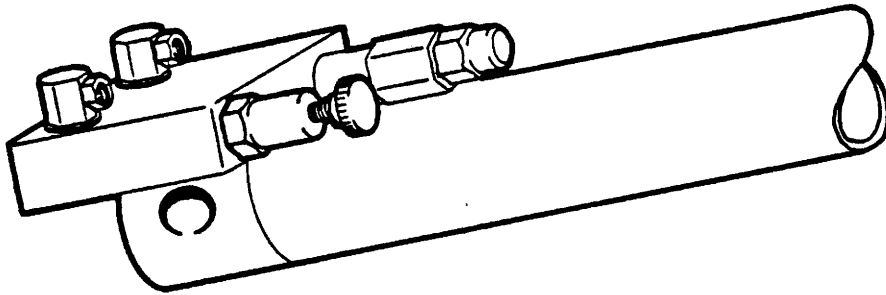

EMERGENCY CONDITION IF OPERATOR IS INCAPACITATED:

Have someone else get first aid or rescue squad immediately!!

- a. DANGER - DO NOT touch unit and attempt to talk with the operator to determine the course of action. Check machine boom sections, work platform and operator for contact with power lines.
- b. Once clear of power lines, switch ground/basket selector to ground controls.
- c. Attempt to talk to operator before taking further action. Make sure that the operator is not pinned in basket.
- d. Check the sequence of operation functions so NOT to accidentally pin operator.
- e. Use the primary power source or the emergency hand pump to lower the work platform to the ground.

OPERATOR TROUBLESHOOTING

WARNING!! SHOULD A MALFUNCTION OR ERRATIC OPERATION OCCUR, OPERATE THE UNIT ONLY LONG ENOUGH TO RETURN TO THE GROUND. IMMEDIATELY REPORT THE INCIDENT TO YOUR SUPERVISOR.

WHAT TO CHECK IF UNIT WILL NOT OPERATE:

1. Emergency buttons turned clockwise at both the basket and ground control panels.
2. Ground/basket selector in proper position.
3. Key switch on.
4. Battery cables connected. Battery fully charged (electric unit).
5. Speed selector operational.
6. Gas or dual fuel tank filled (engine-powered unit).

PRE-DELIVERY and INSPECTION

I. UNLOADING INSTRUCTIONS:

- A. Inspect outside of unit for damage. Be sure to inspect the underside as well as the outside surfaces. Inspect all hoses and cables for damage. Inspect wheel lug nuts and all turntable bolts for loosening during transport.
- B. Remove any strapping which was securing the superstructure during transport.
- C. Unlock and open the engine and/or battery compartments. Inspect all electrical connections and hydraulic hoses for damage. Remove turret lock pin and stow properly.
- D. Connect battery cables to quick disconnects located in the battery compartment.
- E. If unit is equipped with a gas engine, check engine oil. Check for loose wires and remove any foreign matter from around the engine area.
- F. Check hydraulic oil level. If oil level is low or below the add line, add MOBIL DTE13 or equivalent.

II. START-UP INSTRUCTIONS:

- A. Insert key in key switch on the lower control panel. Turn the key clockwise to activate control circuits.
- B. If power light does not illuminate, check and make sure that both emergency stop buttons are turned clockwise.
- C. Make sure unit functions operate properly from the lower control panel and the upper control panel. The correct procedures to check function operations are found in this Operator's Manual.
- D. If engine-equipped, make sure that the engine is operating at correct rpm's.
- E. To operate the unit while in the basket, make sure that the selector on the lower control panel has been switched to the basket mode. Depress the foot pedal to activate functions at basket control panel.
- F. While operating a function, depress the emergency stop button to make sure all functions stop. To re-activate unit, turn stop button clockwise.
- G. Raise the lower boom so the basket clears any obstacles. When boom is raised more than 6 inches, driving speed is automatically reduced.
- H. Drive unit off transport vehicle. The brake system is automatically released for the drive function when the foot pedal is depressed.