

TECH  
SPEC

# IC-20

IC-20-10 as per BMC

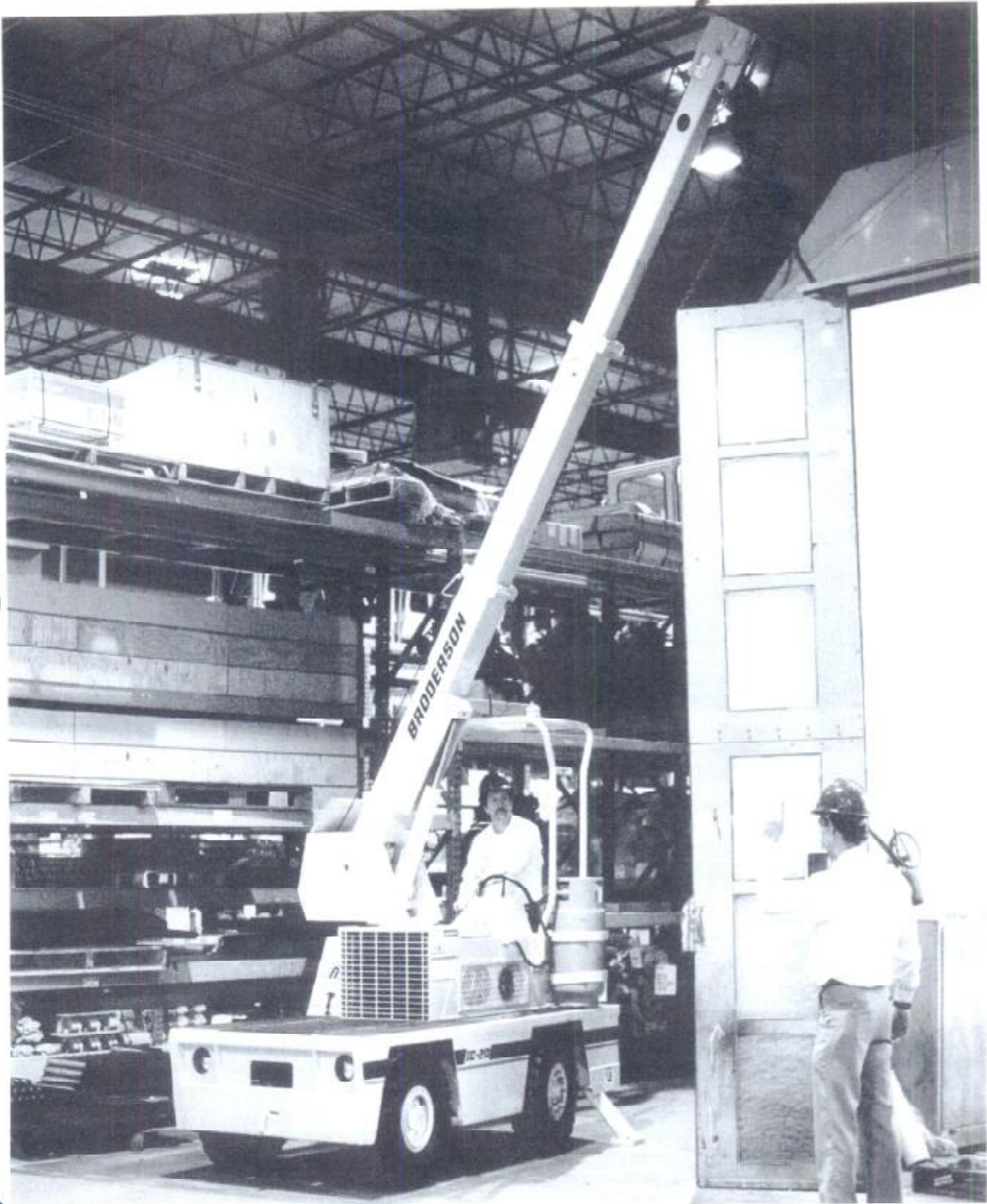

**DMC<sup>®</sup> BRODERSON<sup>®</sup>**  
Manufacturing Corp.

P.O. Box 14770, Lenexa, KS 66285-4770

# IC-20

CAPACITIES APPLY TO OPERATION ON FIRM LEVEL SURFACE					
LOAD RADIUS FEET	3-SECTION BOOM				7-FT. JIB ON RUBBER OR OUTRIGGER
	RIGHT FRONT WORK AREA	LEFT FRONT WORK AREA	LEFT SIDE ON RUBBER	LEFT SIDE ON OUTRIGGER	
4	2500	5000	5000	5000	1300
5	2000	4000	4000	4000	1100
6	1500	3000	2625	3000	750
8	1400	2500	1650	2426	650
10	1300	1950	1025	1500	550
12	1200	1575	750	1075	500
15	1100	1125	500	750	500
17					425
19					325
22					225

CAPACITIES ON OUTRIGGER ARE 85% OF TIPPING LOADS. CAPACITIES ON RUBBER ARE 75% OF TIPPING LOADS. CAPACITIES BELOW **BOLD** LINE ARE LIMITED BY TIPPING. OTHER CAPACITIES ARE LIMITED BY STRUCTURAL OR HYDRAULIC CAPACITY.

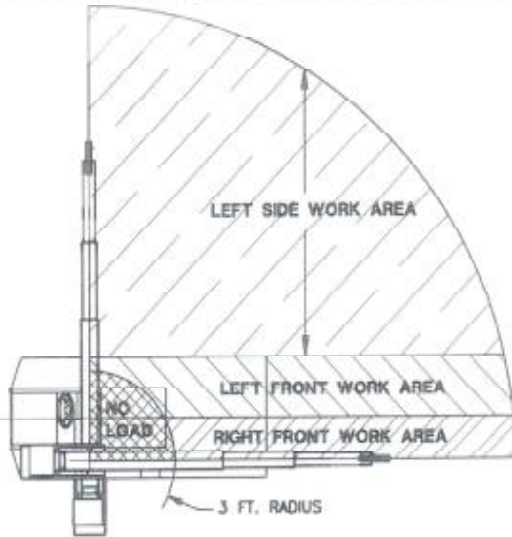

WORK AREA DIAGRAM

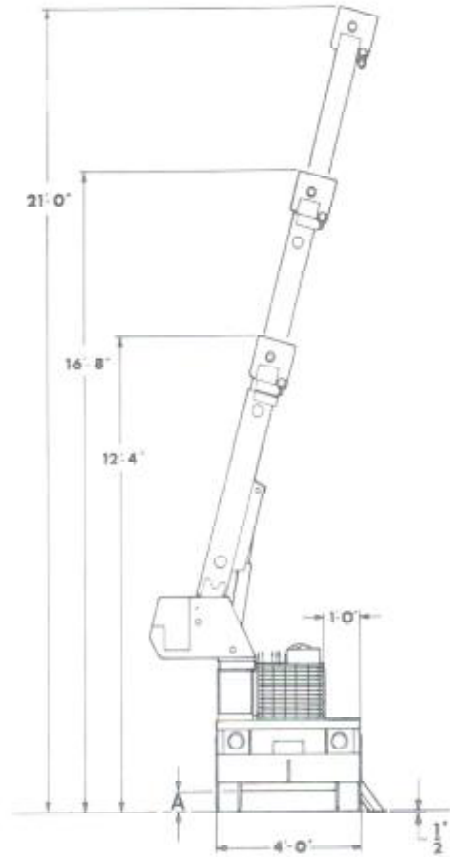
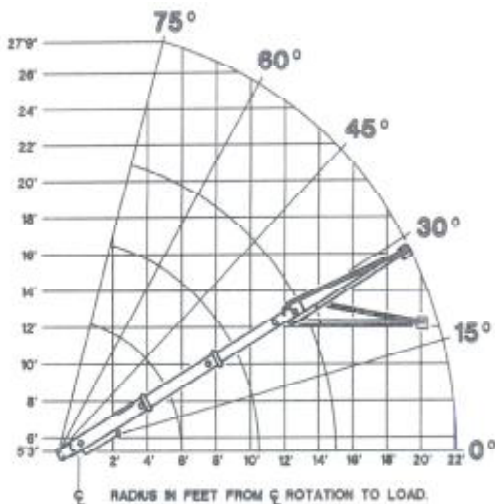
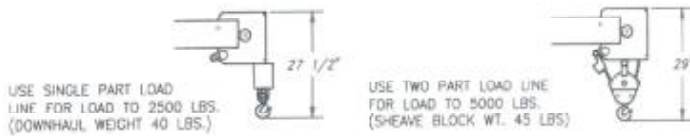

	A	B	C
IC-20-1D	6 1/2"	3' 5 1/2"	27°
IC-20-1DE	5"	3' 10"	27°

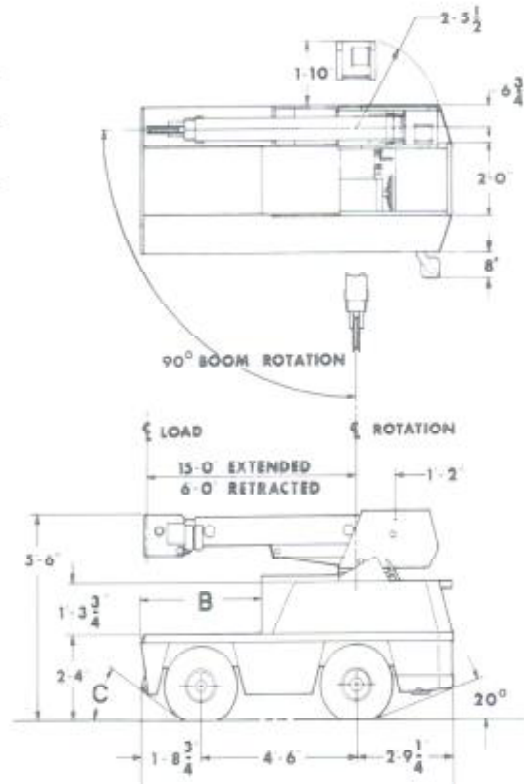

General:	IC-20-1D	IC-20-1DE Electric
Weight	5,850 lbs.	6,300 lbs.
Travel Speed	Up to 5 MPH	Up to 3 MPH
Drawbar Pull	2,800 lbs.	3,000 lbs.

#### Power:

IC-20-1D Engines:	Standard	Optional
Make	Ford	Perkins
Model	VSG413	104.19-IDI
Type	Gas	Diesel
Cylinders	4	4
Displacement	79 CID	122 CID
HP @ Governed Speed	38 HP	39 HP
Fuel Tank Capacity	13.5 Gallons	

#### IC-20-1DE (Electric):

Drive powered by 48 VDC electric motor with SCR control. Hydraulic pump powered by 48 VDC electric motor.

#### Hydrostatic Pump:

##### IC-20-1D Only:

Piston type, 2.8 CID/Rev direct driveline driven from engine crankshaft.

#### Axles:

##### Front Drive Axle:

##### IC-20-1D:

Contains planetary geared torque hubs and high torque hydraulic drive motors. Axle oscillates a total of 1-1/2".

##### IC-20-1DE (Electric):

Single stage planetary gearbox is direct-mounted on drive motor. Non-oscillating axle.

##### Rear Steering Axle:

Non-oscillating.

#### Steering:

Full hydraulic unit with one 2-1/2" cylinder attached to rear axle.

#### Brakes:

##### IC-20-1D:

Disc brake built into each torque hub to hold crane chassis when not being driven.

##### IC-20-1DE (Electric):

Brakes are switch-actuated & used for traction control.

#### Tires:

Front - 7.50 x 10 pneumatic, 12-ply rating.

Rear - 7.50 x 10 pneumatic, 16-ply rating.

#### Chassis:

##### Cargo Deck:

Twenty square feet deck area, 5,000 pounds capacity.

##### Outrigger:

One hydraulic outrigger of box beam construction with direct connected holding valve.

#### Operator's Compartment:

Provides one-position access to all chassis and crane functions.

#### Electrical System:

##### IC-20-1D:

12 Volt System

Lighting Group: One pair headlights

Instrument Group:

Fuel, ammeter, oil pressure, water temperature, hydrostatic loop oil temperature gauges and hourmeter.

Back-Up Alarm:

Provides pulsating sound when transmission is in reverse.

##### IC-20-1DE (Electric):

Drives 48 Volt

Controls 24 Volt

Batteries:

Two 24 volt, 170 amp-hour, accessible under hinged deck covers. On-board 48 volt charger.

Instrument Group:

Ammeter, voltmeter, battery meter, hydraulic pressure gauge and hourmeter.

Back-Up Alarm:

Provides pulsating sound when transmission is in reverse.

#### Hydraulic System:

##### IC-20-1D:

Tandem pump mounted to rear of hydrostatic piston pump. Delivers 5 & 16 GPM at rated engine RPM.

##### IC-20-1DE (Electric):

Gear pump driven by separate 48 volt motor.

Delivers 6 GPM at 500 PSI.

Hydraulic oil tank capacity 9.5 gallons.

#### Boom:

##### Boom Assembly:

Three-section boom assembly equipped with bearing pads, double-acting hydraulic cylinders equipped with direct-connected holding valves. Boom angle indicators on left side of boom.

##### Boom Movements:

Rotation 90°

Elevation 0° to 75°

Telescope 6' to 15'

##### Boom Swing:

Two double-acting hydraulic cylinders connected to turntable torque tube provides 90° rotation. Heavy-duty ball bearing rotation gear supports boom.

##### Boom Hoist:

Turret-mounted, hydraulically powered hoist, provides bare drum line pull of 3,100 lbs. at a speed of 46 fpm on the IC-20-1D and 3,500 lbs. at 26 fpm on the IC-20-1DE. Includes downhaul weight, swivel hook and 80 feet of 5/16 inch wire rope.

##### Anti-Two Block Device:

Prevents damage to hoist rope and/or crane components from pulling load hook against tip.

##### Sheave Block, Two-Part:

Single sheave block for 2-part-line requirements.

# IC-20

Listed below are brief descriptions of each option available for the IC-20-1D & IC-20-1DE Industrial Cranes. Consult the IC-20-D Engineering Spec for additional information on each option.

1. **IC-20-1D, 2-1/2 Ton Industrial Crane with Gas Engine.**
2. **IC-20-1DE, 2-1/2 Ton Industrial Crane with "Electric Motors."**

#### Engine Options: (IC-20-1D Only)

4. **LP Gas System**  
Contains all necessary components for LP Gas.
5. **Dual Fuel System**  
Contains all necessary components to burn LPG or gasoline.
6. **Perkins Diesel Engine**  
Perkins Model 104.19-IDI
7. **Spark Arrester Muffler**  
Installed in addition to std. muffler.
8. **Engine Shutdown Gauges**  
Shuts engine off when high water temperature or low engine oil pressure occurs.

#### Tire Option:

10. **Solid Rubber Tires**  
For applications where hazardous ground conditions exist.

#### Cargo Deck Option

11. **Deck Mats**  
Protects delicate loads from scratching and reduces sliding of heavy loads during travel.

#### Chassis Options:

12. **Auxiliary Winch (IC-20-1D Only)**  
Mounted behind front bumper, hydraulically driven with control in operator's console (3,000 lbs. @ 20 FPM).

#### Chassis Options: Cont'd

13. **Pintle Hook**  
Pintle hook mounted on rear frame, 5 ton capacity.
14. **Lifting Sling & Bracket Installation**  
Three-leg hitch consisting of heavy-duty pear link & three wire ropes with swaged-on clevis ends for attaching to lift points on crane chassis and turntable. Lifting points included.
15. **Lifting Sling Brackets**  
Includes two lift rings in front deck and lug on turntable for attaching lifting sling cables. Cables not included.
16. **Lifting Sling**  
Three leg lift sling only.

#### Operator Compartment Options:

17. **Operator Guard**  
Tubular steel weldment with heavy expanded steel mesh top section. Overhead height with guard installed 90 inches.
18. **Floor Mat**  
Vinyl mat with foam backing.

#### Electrical Options: (IC-20-1D Only)

19. **TailLight**  
Taillight mounted in protective bracket welded to left rear panel on chassis.
20. **Lighted Instrument Gauges**  
Instrument gauges equipped with lights for night operations.
21. **Strobe Light**  
One yellow strobe light mounted on top of operator's guard for high visibility. When the operator's guard is not ordered the strobe light is mounted on left-hand frame rail.

#### Electrical Options: Cont'd (IC-20-1D Only)

22. **Boom Work Lights**  
One work light mounted to boom to light boom tip and one work light mounted to turret to light ground under boom tip.
23. **Boom Swing Lock**  
Prevents boom from being swung in normal 90° arc.
24. **7 Foot Pin-on Jib**  
Consists of jib with pair of tension bars, tip sheave, cable keeper, pins & jib attaching pins. Tension bars provide two positions: In-line & 30° offset.
25. **Load Moment Indicator**  
Warns operator of impending overload with audible and visual signals. Prevents overload by stopping boom functions that cause overloads. Readouts for load, boom angle, boom length and load radius.
26. **Load Indicator**  
Includes 3-sheave load sensor on top of boom and readout box on top of instrument panel.

Should you, as the end user, require an option or special equipment on your IC-20-1D or IC-20-1DE that is not listed on our sales literature, please contact your dealer salesperson or the factory to receive a special quoted price.