

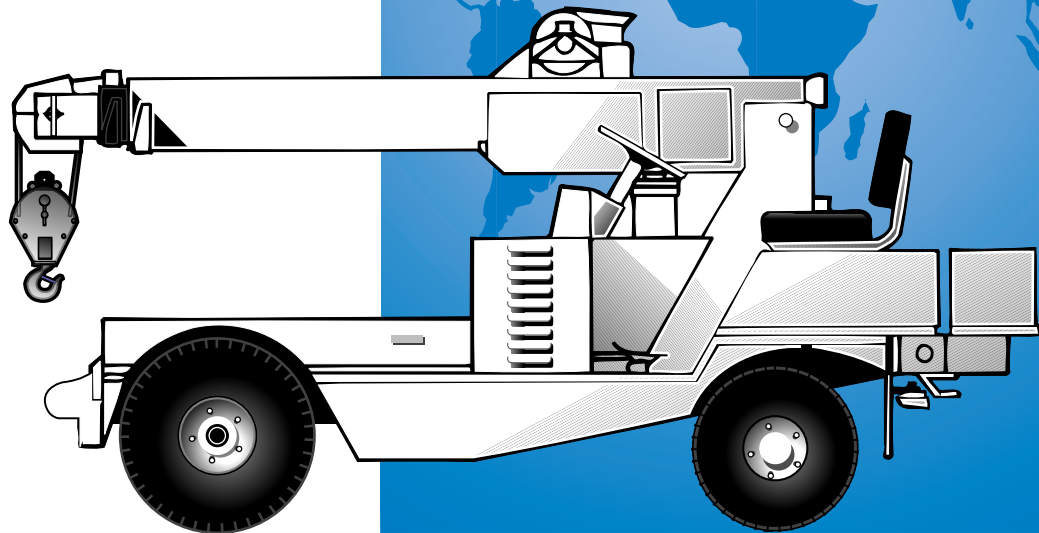

GROVE[®]
CRANE

A GROVE WORLDWIDE COMPANY

STEVEDORE 4000



Material Handling Hydraulic Crane

Specifications

Boom

8 ft. - 18 ft. (2.4 m - 5.5 m) three-section full power boom. Maximum tip height: 20 ft. (6.1 m).

*Optional Swingaway Extension

7 ft. (2.1 m) swingaway extension. Stows alongside base boom section.

Maximum tip height: 26 ft. (7.9 m).

Boom Nose

One sheave mounted on bronze bushings.

Boom Elevation

One double acting hydraulic cylinder with integral holding valve provides elevation from 0° to 60°.

Control Station

Frame mounted, open control station includes all crane function and driving controls, engine instrumentation and deluxe vinyl seat with seat belts.

Counterweight

Fixed, bolted to frame.

Hydraulic System

One main gear pump, capacity of 7.5 GPM (28.4 LPM), driven by carrier engine through PTO (10 GPM - [37.9 LPM] with diesel).

Proportional four way double acting control valves.

2 return line type filters, full flow by-pass protection and 10 micron rated replaceable cartridges.

24 gallon (90.8 L) reservoir with spin-on breather filter, external sight gauges, clean out access, mounted to frame.

HOIST SPECIFICATIONS

Power up and down equal speed, planetary reduction with automatic spring applied multi-disc brake and hoist drum cable follower.

Main Hoist HDC 100B

Maximum Single Line Speed:

Bottom Layer: 19 fpm (5.8 mpm)

Top Layer: 21 fpm (6.4 mpm)

Maximum Single Line Pull:

Bottom Layer: 3,370 lbs. (1529 kg)

Top Layer: 3,050 lbs. (1383 kg)

Maximum Permissible Single Line Pull: 5:1 Strength Factor 3,320 lbs. (1506 kg) with 3/8 in. (9.5 mm) 18 x 19 class.

Maximum Rope Stowage: 220 ft. (67 m). Note: 60 ft. (18.3 m) length of wire rope and single sheave 2 ton (1.8 tonne) hookblock supplied with basic standard unit.

Frame

High strength alloy steel construction.

Engine

ONAN P218G two cylinder air-cooled gasoline - 47.7 c.i. (.8 L), 18 bhp (13.4 kW) (Gross) @ 3,600 rpm. Maximum torque: 31.5 ft. lbs. (43 Nm) @ 2,200 rpm.

Fuel Tank

13.5 gallons (51 L)

Electrical System

One 12 V maintenance free battery.

Drive

4 x 2

Steering

Rear: Full hydraulic power controlled by steering wheel.

Transmission

Hydrostatic

Axles

Front: Drive-type torque hubs (rigid mounted to the chassis).

Rear: Wide track steer-type pivot mounted allows 2-1/4 in. (57 mm) of oscillation.

Tires

Front: 7.50 x 10-10PR pneumatic

Rear: 6.90 x 9-6PR pneumatic

Brakes

Hydraulic drum and shoe type acting on front drive wheels. Spring applied hydraulically released parking brake acting on front drive wheels.

Lights

Full lighting package including head and tail.

Maximum Speed

6 mph (10 kph)

Gradeability (Theoretical)

28% (theoretical based on 5,620 lbs. [2549 kg] GVW)

Miscellaneous Standard Equipment

Electronic backup alarm.

16 sq. ft. (1.48 m²) carry deck area.

*Optional Equipment

* Hourmeter

* Tool kit

* Solid rubber tires

* LP gas conversion kit (less bottle)

* Foam filled tires

* Maintenance platform (static capacity of 500 lbs. [227 kg] on main boom).

* Spark arrestor muffler

**Denotes optional equipment*

Working Range



8 - 18 ft.
(2.4 - 5.5 m)

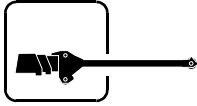

7 ft.
(2.1 m)

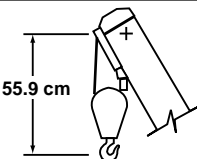
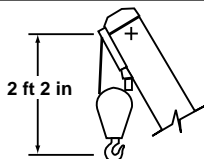
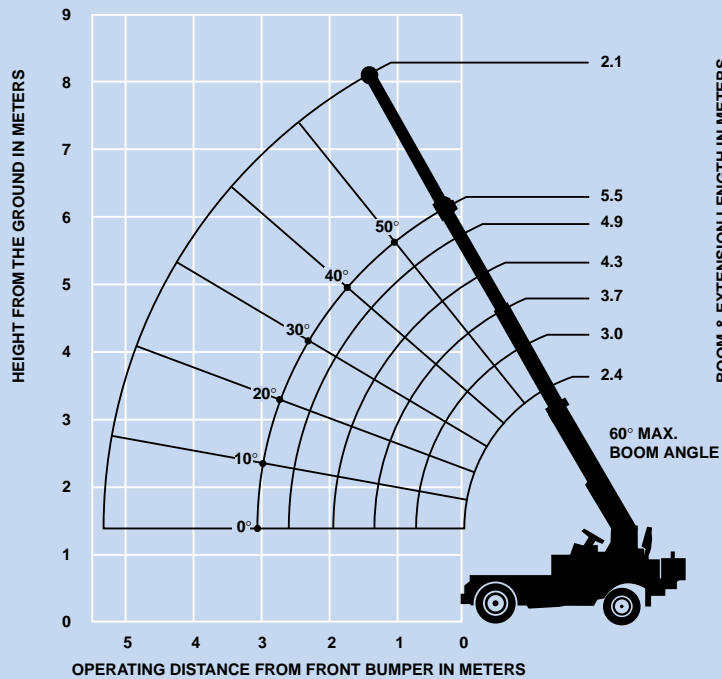
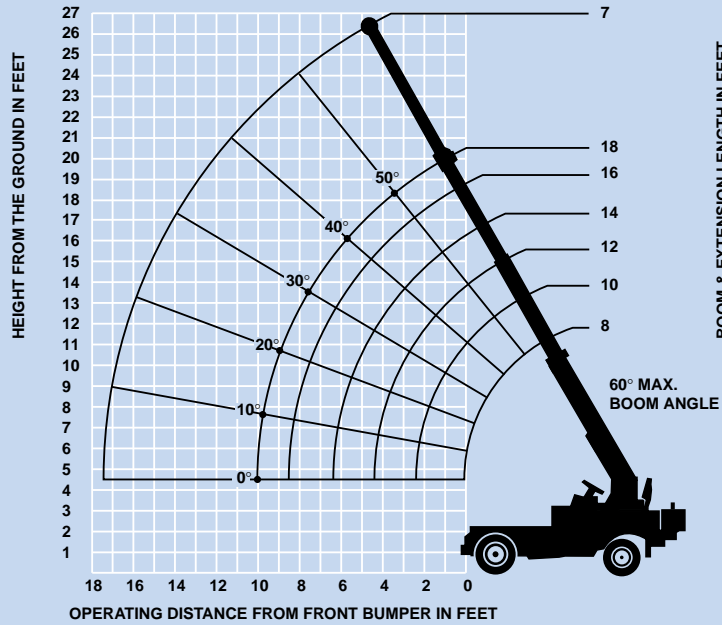

DIMENSIONS ARE FOR LARGEST GROVE FURNISHED HOOKBLOCK AND HEADACHE BALL, WITH ANTI-TWO BLOCK ACTIVATED.

Lifting Capacities

CRANE CAPACITIES

DISTANCE FROM FRONT BUMPER		MAXIMUM STATIC LIFT CAPACITY		PICK & CARRY CAPACITY	
FEET	METERS	POUNDS	KILOGRAMS	POUNDS	KILOGRAMS
2	0.61	4,000	1810	3,100	1405
3	0.91	3,090	1400	2,600	1175
4	1.22	2,435	1100	2,100	950
5	1.52	2,060	930	1,700	770
6	1.83	1,680	760	1,500	680
7	2.13	1,400	635	1,300	585
8	2.44	1,120	505	1,055	475
9	2.74	930	420	880	395
10	3.05	840	380	795	360

CARRY DECK CAPACITY 4,000 LBS. (1814 KG)

JIB CAPACITIES (SINGLE LINE OPERATION ONLY)

DISTANCE FROM FRONT BUMPER		MAXIMUM STATIC LIFT CAPACITY	
FEET	METERS	POUNDS	KILOGRAMS
MIN THRU 10	MIN THRU 3.05	795	360
12	3.66	705	315
14	4.27	660	295
16	4.88	570	255
17.5	5.33	530	240

Dimensions

TURNING RADIUS
10' 7-1/2" (3.24 m)
CLEARANCE RADIUS
12' 5" (3.79 m)

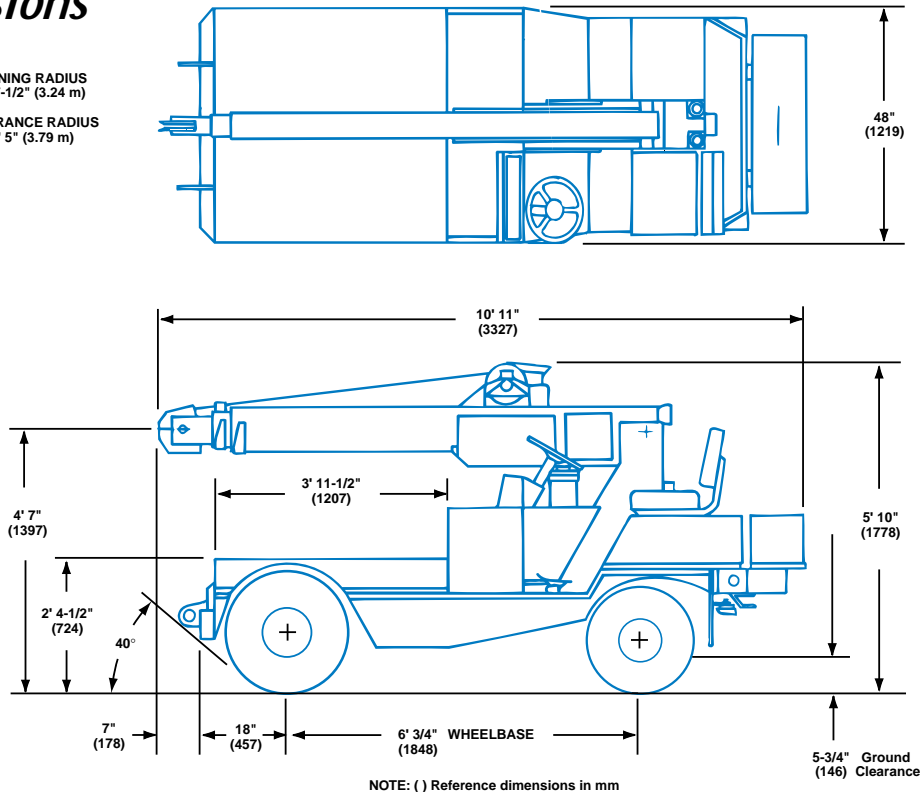

TRAVEL WEIGHTS

Front Axle Load	2,180 lbs. (980 kg)
Rear Axle Load	3,440 lbs. (1560 kg)
Gross Vehicle Weight	5,620 lbs. (2549 kg)





































Rated Lifting Capacities

IMPORTANT NOTES:

WARNING: THIS CHART IS ONLY A GUIDE.
The notes below are for illustration only and should not be relied upon to operate the crane.
The individual crane's load chart, operating instructions and other instruction plates must be read and understood prior to operating the crane.

Capacity charts are based on the machine standing on a firm, level and uniform surface. Capacities are based on structural strength and do not exceed 75% of tipping. Two parts of line required for capacities greater than 3,000 lbs. (1360 kg).

Symbols Glossary

	Frame		Steering
	Outriggers		Transmission
	Outrigger Controls		Axles
	Engine		Brakes
	Fuel Tank Capacity		Tires
	Electrical System		Suspension
	Drive		Rotation
	Lights		Boom Elevation
	Cab		Swing
	Boom		Counterweight
	Fixed Swingaway		Oil
	Tele-Swingaway		Hydraulic System
	Jib		Hoist
	Boom Nose		Radius
	Boom Extension		Boom Length
	Speed		Hookblock
	Grade		Gear
	Lattice Extension		Luffing Jib

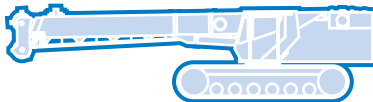
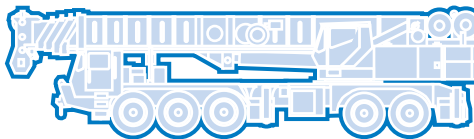
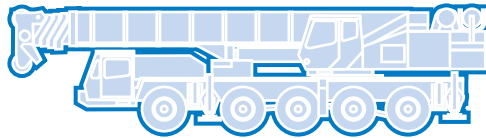

Grove Worldwide – World Headquarters

Grove North America
1565 Buchanan Trail East
P.O. Box 21
Shady Grove, Pennsylvania 17256, U.S.A.
Tel: [Int + 1] (717) 597-8121
Fax: [Int + 1] (717) 597-4062
Western Hemisphere, Asia/Pacific

Grove Europe Limited*
Sunderland SR4 6TT, England
Tel: [Int + 44] 191 565-6281
Fax: [Int + 44] 191 564-0442
Europe, Africa, Middle East

Grove Europe Limited*
P.O. Box No. 268
4A Kimber Road
Abingdon, Oxfordshire, OX141SG
Tel: [Int + 44] 1235 55-3184
Fax: [Int + 44] 1235 55-3218
*Grove Europe Limited, Registered in England,
Number 1845128, Registered office, Crown Works,
Pallion, Sunderland, Tyne & Wear, England SR4 6TT

Deutsche Grove GmbH
Sales and Service
Helmholtzstrasse 12, Postfach 5026
D-40750 Langenfeld, Germany
Tel: [Int + 49] (2173) 8909-0
Fax: [Int + 49] (2173) 8909-30

Wilhelmshaven Works
Industriegelände West, Postfach 1853
D-26358 Wilhelmshaven, Germany
Tel: [Int + 49] (4421) 294-0
Fax: [Int + 49] (4421) 294-301

Grove France S.A.
16, chaussée Jules-César, 95520 OSNY
B.P. 203, 95523 CERGY PONTOISE CEDEX
France
Tel: [Int + 33] (1) 30313150
Int: [Int + 33] (1) 30386085

Grove Asia/Pacific - Regional Office
171 Chin Swee Road
#06-01 San Centre
Singapore 0316
Tel: [Int + 65] 536-6112
Fax: [Int + 65] 536-6119
Asia/Pacific, Near East

Grove China - Representative Office
Beijing Hotel Room 6074
No. 33 East Chang An Avenue
Beijing, 100004, China
Tel: [Int + 86] (10) 513-7766
Fax: [Int + 86] (10) 513-7307

Grove Product Support
Western Hemisphere, Asia/Pacific
1086 Wayne Avenue
Chambersburg, Pennsylvania USA
Tel: [Int + 1] (717) 263-5100
Fax: [Int + 1] (717) 267-0404

Europe, Africa, Middle East
Sunderland SR4 6TT, England
Tel: [Int + 44] 191 565-6281
Parts Fax: [Int + 44] 191 510-9242
Service Fax: [Int + 44] 191 510-9560

<http://www.grovetworldwide.com>

Constant improvement and engineering progress make it necessary that we reserve the right to make specification, equipment, and price changes without notice. Illustrations shown may include optional equipment and accessories and may not include all standard equipment.

Distributed By: