

Specifications

Hydraulic Rough Terrain Crane

GENERAL INFORMATION ONLY

HSP-8018

18-ton (16.33 metric ton)

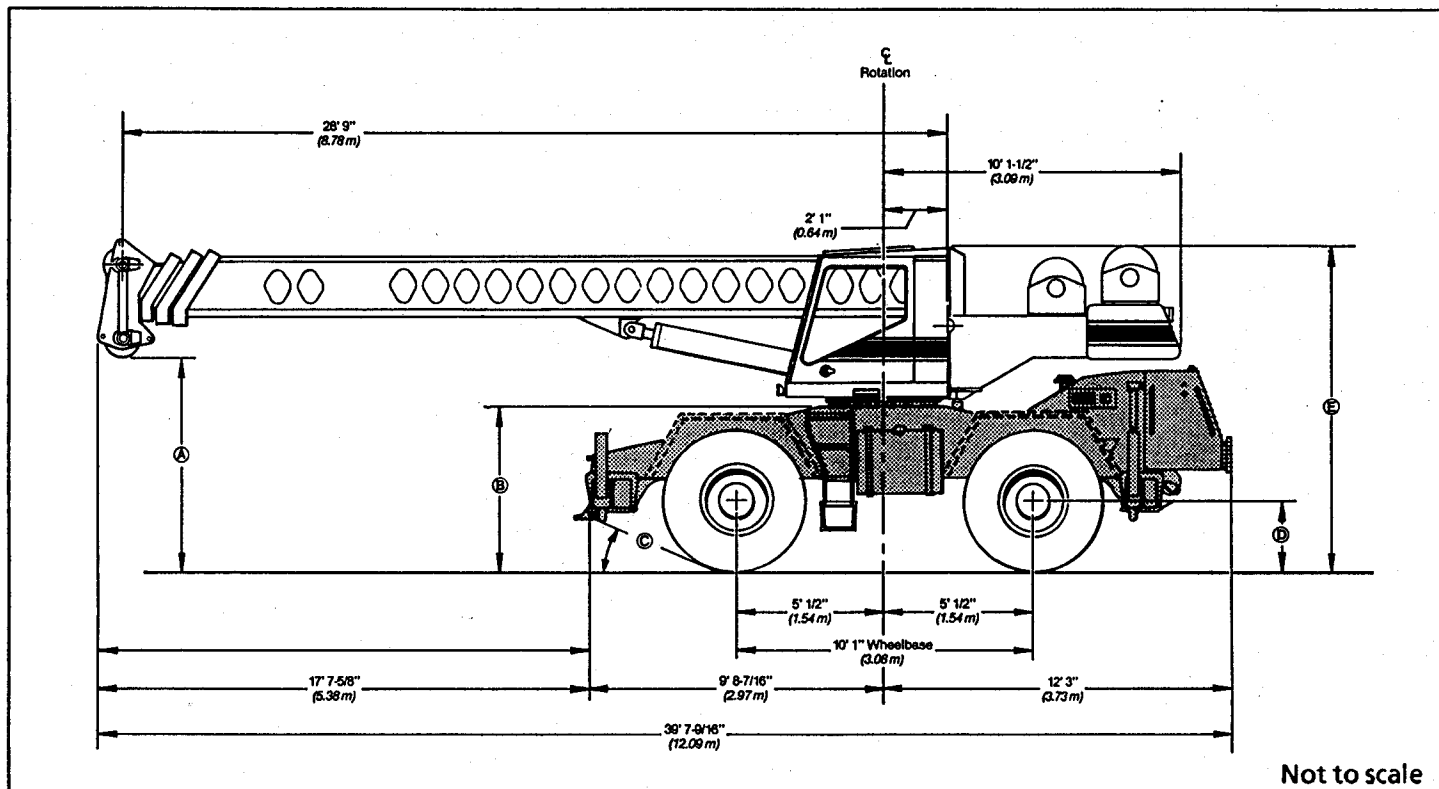

Not to scale

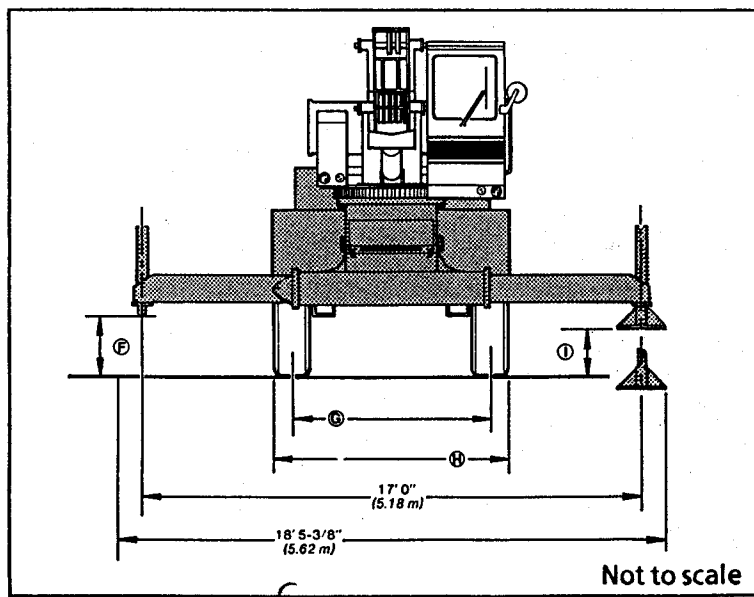

Not to scale

General dimensions	Feet	Meters
Turning Radius (4-wheel steer)	15' 10"	4.83
Tailswing of counterweight:	10' 6"	3.20

Dimensions affected by tires

Tires	16.0 X 24 (16-PR)		20.5 X 25 (20-PR)	
	Feet	meters	Feet	meters
A	-	-	8' 3/4"	2.46
B	5' 7-5/16"	1.71	5' 8-1/4"	1.73
C	19.4°	-	20°	-
D	2' 1-13/16"	0.66	2' 4-9/16"	0.73
E	11' 7/16"	3.36	11' 2-3/4"	3.42
F	20-1/8"	0.51	21"	0.53
G	6' 6-7/16"	1.99	6' 11-7/16"	2.12
H	8' 0"	2.44	8' 8-13/16"	2.66
I	12-1/8"	0.31	13"	0.33

Upperstructure

GENERAL INFORMATION ONLY

■ Boom

Patented Design. 28'9" — 70'3" (8.76 m — 21.41 m) three-section boom with two power sections. Boom side plates have diamond shaped impressions for superior strength to weight ratio and 100,000 p.s.i. (689.5 MPa) steel angle chords for lateral stiffness. Boom telescope sections are supported by wear shoes both vertically and horizontally to prevent metal to metal contact. Anti-two block with audio visual warning.

Optional boom — 28'9" — 49'6" (8.76 m — 15.09 m) 2-section boom with one power section.

Optional boom — 28'9" — 91'0" (8.76 m — 27.74 m) 4-section boom with two power sections and one manual section.

Boom head — Four 10-5/8" (0.27 m) root diameter head sheaves handle up to 8 parts of wire rope. Two easily removable wire rope guards, and rope dead end lugs provided on each side of boom head. Optional 12-1/8" (0.31 m) root diameter head sheaves; meets 23:1 ratio European safety code with 14 mm wire rope.

Auxiliary lifting sheave — Optional. Single 10-5/8" (0.27 m) root diameter sheave with removable wire rope guard, mounted to boom. For use with one or two parts of line off the optional auxiliary winch. Does not affect erection of fly, or use of main head sheaves for multiple reeving.

Boom elevation — One Link-Belt designed hydraulic cylinder with holding valve. Self aligning steel bushings. Hand and optional foot controls for controlling boom elevation from -3° to 80°. Boom angle indicator standard.

■ Fly

Optional — 24' 0" (7.32 m) stowable one-piece lattice type.

■ Jib

Optional — 14'6" (4.42 m) stowable A-frame. Attaches to boom head only. Can be offset 10°, 20° and 30°.

■ Cab and Controls

Environmental cab; isolated from sound and vibration by rubber mounts. All tinted and tempered safety glass windows. Sliding rear and right side window and swing up roof window for maximum visibility and ventilation. Slide-by-door opens to 3'0" (0.91 m) width. 6-way adjustable operator's seat. 4-way adjustable tilt / telescoping steering wheel. Ignition and steering wheel key lock. Control levers for swing, boom telescope, winch and boom hoist. Outrigger controls, sight level bubble. Optional foot control for boom hoist and swing brake.

Cab instrumentation — Dash mounted gauges for hydraulic oil temperature, converter temperature, fuel, water temperature, voltmeter and oil pressure.

■ Swing

Bi-directional hydraulic swing motor mounted to a planetary reducer for 360° continuous smooth swing at 3.0 r.p.m.

Swing parking brake — Manually applied/released, disc brake mounted on the speed reducer.

Swing lock — Standard two position pin-type (over front and rear) operated from the operator's cab.

Counterweight — Bolted to upperstructure frame.

■ Hydraulic system

Main pump — Double gear type pump. Powered by carrier engine through a straight mechanical drive or through an optional mechanical clutch pump disconnect. Pump operates at 2,800 p.s.i. (193.05 Bars) maximum system pressure.

Swing / steering pump — Single gear-type pump. Powered by carrier engine through a straight mechanical drive. Pump operates at 2,500 p.s.i. (172.37 Bars).

Reservoir — 100 gallon (378.50 L) capacity. Double diffusers for deaeration.

Filtration — Two 10-micron filters located inside of hydraulic reservoir. Accessible for easy replacement.

Control valves — Five separate control valves allow simultaneous operation of all crane functions.

■ Load hoist system

Standard: 1M main winch with single speed motor and automatic brake; power up/down mode of operation. Bi-directional gear-type hydraulic motor, driven through a double planetary reduction unit for positive operator control under all load conditions.

Optional — Model 2M main winch with two-speed motor and automatic brake, power up/power down mode of operation. Bi-directional, gear-type hydraulic motor.

Optional — Model 1M auxiliary winch with one-speed motor and automatic brake, power up/power down mode of operation. Available on rear winch only.

Line pulls and speeds — Maximum permissible line pull 9,600 lbs. (4 355 kg) and maximum permissible line speed of 416 f.p.m. (126.80 m/min) on standard 12" (0.30 m) root diameter smooth drum. Maximum permissible line pull 9,015 lbs. (4 089 kg) and maximum permissible line speed 443 f.p.m. (135.03 m/min) on optional 13-1/4" (0.34 m) diameter grooved drum.

■ Miscellaneous standard equipment

Sound suppressed cab, fire extinguisher, seat belt, warning horn, mirrors, travel lights, and windshield wiper.

■ Optional upperstructure equipment

360° house lock, electronic boom angle/length indicator, boom hoist foot control, propane heater, diesel heater, foot actuated swing brake, two-speed main winch, grooved drum, drum rotation indicators, 25-ton (22.68 metric ton) hook block, 30-ton (27.22 metric ton) hook block, 8-1/2 ton (7.71 metric ton) hook ball and swivel, anti two block with function kick-out, load moment device, rear steer indicator, boom mounted working light, engine monitoring system, tachometer, air conditioner, top hatch window wiper, amber rotating beacon, windshield washer, and 360° cab mounted spotlight.

Carrier

GENERAL INFORMATION ONLY

■ Type

8' 0" (2.44 m) wide, 121" (3.07 m) wheelbase.

4 × 4 × 4 — (4-wheel steer, 4-wheel drive)
Standard — for rough terrain with limited turning area.

4 × 2 × 4 — (4-wheel steer, 2-wheel drive);
Optional — for flat terrain with limited turning area.

4 × 4 × 4 — (4-wheel steer, 4-wheel drive)
Optional — Rear axle with no-spin differential; for rough terrain with limited turning area.

Frame — 100,000 p.s.i. (689.5 MPa) steel, double walled construction with integral 100,000 p.s.i. (689.5 MPa) steel outrigger boxes.

■ Axles

Front, Standard — heavy duty planetary drive/steer type.

Rear, Standard — heavy duty planetary drive/steer type.

Rear, Optional — heavy duty non-driving/steer type.

Rear, Optional — heavy duty no-spin differential, planetary drive/steer type.

Suspension

Front axle — Rigid mounted to frame.

Rear axle — Pin-mounted on welded steel box cradle. Automatic hydraulic rear axle oscillation lock-out engages when upper-structure rotates past 2-1/2° of centerline.

Tires

Front and rear
Standard — 20.5 × 25 (20-PR)

Optional — 16.0 × 24 (16-PR)

■ Brake

Service — Air over hydraulic brakes on all four wheels. 17 1/4" × 4" (0.43 m × 0.10 m) drum brakes on each wheel.

Parking — Spring applied, air released; cab controlled, mounted on front axle.

Transmission

Allison 4-speed fully automatic transmission. 8 speeds forward and 2 reverse with 2-speed Rockwell heavy duty transfer case. Electric over air controls. Completely automatic shifting in both low and high range for operator convenience.

Steering — Hydraulic two wheel, four wheel and "crab" steering; controlled from tilt telescoping steering wheel.

■ Outriggers

Four hydraulic, telescoping beam and jack outriggers. Vertical jack cylinders equipped with integral holding valve. Beams extend to 17' 0" (5.18 m) centerline-to-centerline and retract to within 8'0" (2.44 m) overall width. Equipped with stowable, lightweight 17-3/8" (0.44 m) square steel floats. Controls and sight level bubble located in upperstructure cab.

Miscellaneous standard equipment

Cab steps, 2 front and rear carrier steps, skid resistant finish on carrier deck, storage compartment, automatic rear axle disconnect, and fenders.

Optional chassis equipment

24-volt start, no-spin differential on rear axle, front and rear towing shackles, lifting lug package, engine block heater, ether injection package, spare tires and rims, pintle hook, manual pump disconnect, auxiliary steering system, air dryer, and carrier mounted working lights.

Travel speeds and gradeability

Engine	Tires	Maximum Speed		Gradeability at stall	Maximum tractive effort at stall		Gradeability at 1.0 mph (1.61 km/h)	Maximum tractive effort at 1.0 mph (1.61 km/h)	
		mph	km/h		pounds	kg.		pounds	kg.
GM 8.2N	16.0 × 24 20.5 × 25	18.1	29.1	186% 130%	39,886	18 092	66% 60%	25,148	11 407
		19.4	31.2		37,090	16 824		24,210	10 982
Cummins V378C*	16.0 × 24 20.5 × 25	19.4	31.2	133% 104%	36,200	16 420	62% 56%	23,978	10 876
		20.9	33.6		33,662	15 269		22,922	10 397

*Optional Equipment

Engine	GM 8.2N	Cummins V-378C*
Cylinders - cycle	8-4	6-4
Bore	4.25" (108.0 mm)	4.62" (117.5 mm)
Stroke	4.41" (112.0 mm)	3.75" (95.3 mm)
Displacement	500 cu. in. (8 200 cm ³)	378 cu. in. (6 195 cm ³)
Maximum brake hp	130 @ 2800 rpm	145 @ 3000 rpm
Peak torque	330 ft. lbs. (447 J)	280 ft. lbs. (380 J)
Electric system	12 volt negative ground	12 volt negative ground
Fuel capacity	75 gallons (283.9 L)	75 gallons (283.9 L)
Alternator	80 amps	80 amps
Crankcase capacity	12 quarts (11.4 L)	18 quarts (17.0 L)
Air compressor	12 c.f.m. (0.34 m ³ /min)	13.2 c.f.m. (0.37 m ³ /min)

Axle loads 3-section boom

Base machine with standard 28' 9"-70' 3" (8.67 m - 21.41 m) three-section boom, 385' (117.35 m) 9/16" (14 mm) wire rope, 4 x 4 x 4 carrier with GM 8.2N engine, 20.5 x 25.0 tires, counterweight.	G.V.W. [⊙]		Upper facing front				Upper facing rear			
			Front axle		Rear axle		Front axle		Rear axle	
	lbs.	kgs.	lbs.	kgs.	lbs.	kgs.	lbs.	kgs.	lbs.	kgs.
	45,987	20 860	22,862	10 370	23,124	10 489	17,436	7 909	28,550	12 950
16.0 x 24.0 tires	-1,430	-649	-715	-324	-715	-324	-715	-324	-715	-324
Hookblock at bumper	350	176	577	261	-227	-103	—	—	—	—
Headache ball at bumper	325	147	506	230	-81	-82	—	—	—	—
Auxiliary lifting sheave	75	34	243	110	-168	-76	-168	-76	243	110
14' 6" (4.42 m) A-frame jib stowed	575	261	1,337	606	-762	-346	-762	-346	1,337	606
24' (7.32 m) lattice fly stowed	480	218	922	418	-442	-200	-442	-200	922	418
2-section boom and counterweight reduction	-3,956	-1 794	-3,632	-1 647	-324	-47	-324	-147	-3 632	-1 647

Axle loads 4-section boom

Base machine with optional 28' 9" - 91' (8.76 m - 27.74 m) 4-section boom, 400' (121.92 m) 9/16" (14 mm) wire rope, 4 x 4 x 4 carrier with GM 8.2N engine, 20.5 x 25.0 tires, counterweight.	G.V.W. [⊙]		Upper facing front				Upper facing rear			
			Front axle		Rear axle		Front axle		Rear axle	
	lbs.	kgs.	lbs.	kgs.	lbs.	kgs.	lbs.	kgs.	lbs.	kgs.
	46,588	21 113	23,570	10 691	23,018	10 441	15,156	6 874	31,432	14 257
16.0 x 24.0 tires	-1,430	-649	-715	-324	-715	-324	-715	-324	-715	-324
Hookblock at bumper	350	176	577	261	-227	-103	-	-	-	-
Headache ball at bumper	325	147	506	230	-181	-82	-	-	-	-
Auxiliary lifting sheave	75	34	243	110	-168	-76	-168	-76	243	110
14' 6" (4.42 m) A-frame jib stowed	575	261	1,337	606	-762	-346	-762	-346	1,337	606
24' (7.32 m) lattice fly stowed	480	218	922	418	-442	-200	-442	-200	922	418

[⊙] Adjust gross vehicle weight & axle loading according to component weight.

Note: All weights are ± 3%.

• Link-Belt is a registered trademark.

We are constantly improving our products and therefore reserve the right to change designs and specifications.

Link-Belt Construction Equipment Company Lexington, Kentucky