

TELESCOPIC CRAWLER CRANE

KOBELCO

TK550

Max. Lifting Capacity: 55.0 metric ton
Max. Boom Length: 30.1 m

S P E C I F I C A T I O N S

CRANE PERFORMANCE	
Max. rated load	
9.97 m boom	55.0 ton x 3.0 m (12-line)
16.7 m boom	28.0 ton x 5.0 m (6-line)
23.4 m boom	22.0 ton x 6.0 m (5-line)
30.1 m boom	14.0 ton x 6.5 m (4-line)
Aux. Sheave	5.0 ton (single-line)
Main boom length	9.97 m to 30.1 m
Main hook height	30.7 m
Main hook operating radius	27.6 m
Line Speed	
Main	125 m/min at 4th layer
Aux.	110 m/min at 2nd layer
Third (Option)	100 m/min at 3rd layer
Rated Line Pull	
Main	44.1 kN (4.5 ton)
Aux.	49.0 kN (5.0 ton)
Third (Option)	29.4 kN (3.0 ton)
Boom telescoping speed	120 sec/20.1 m
Boom raising speed	64 sec/0 to 82.5°
Swing speed	2.3 min ⁻¹ (rpm)
BOOM STRUCTURE	
Main boom	Four section, box construction, 2nd and 3rd simultaneously telescoping 4th independently telescoping
Boom hoist device	Direct forced type by double acting hydraulic cylinder (one)
Boom telescoping device	Direct forced type by double acting hydraulic cylinders (three)
Load hoist device	Hydraulic motor drive with spur gear reduction with auto-brake, independent 2 winches with free-fall function
Swing device	Hydraulic drive motor with planetary gear reduction with hand brake, swing neutral-free or neutral -brake selector type

WIRE ROPE	
Main winch	18 dia. X 180 m, IWRC 6 x WS (26) anti twist rope
Aux. winch	18 dia. X 80 m, 6 x WS (26) anti twist rope
Third. Winch (Option)	16 dia. X 80 m, 6 x Fi (29) anti twist rope
Hydraulic device	2 variable plunger pumps + 3 - pumps (2 variable plunger pumps + 1 gear pump)
Hydraulic oil tank	610 liters
UPPERSTRUCTURE	
Engine	
Model	MITSUBISHI 6D16-TLE1
Type	Water cooled, 4 cycle, 6 cyls, direct injection diesel with turbochager, intercooler
Total displacement	7,540 cc
Max. output	147 kW/2,000 min ⁻¹ (rpm)
Max. torque	765 N.m/1,600 min ⁻¹ (178 kgf.m/1,600 rpm)
Fuel tank	270 liters
LOWERSTRUCTURE	
Propel system	Hydraulic motors, planetary reducer, direct drive, shoe-in type
Travel speed	1.9/1.2 km/h
Gradeability	30 % (16.7°)
OPERATING WEIGHT	
Operating weight	49.98 tons
Ground pressure	68.3 kPa (0.70 kgf/cm ²)

GENERAL DIMENSIONS

Unit: mm

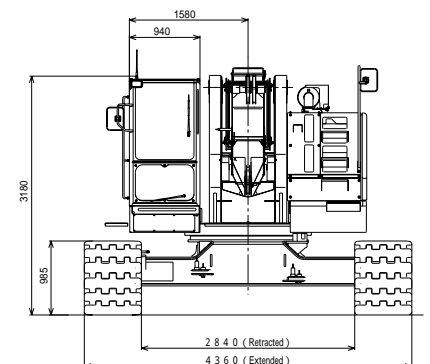
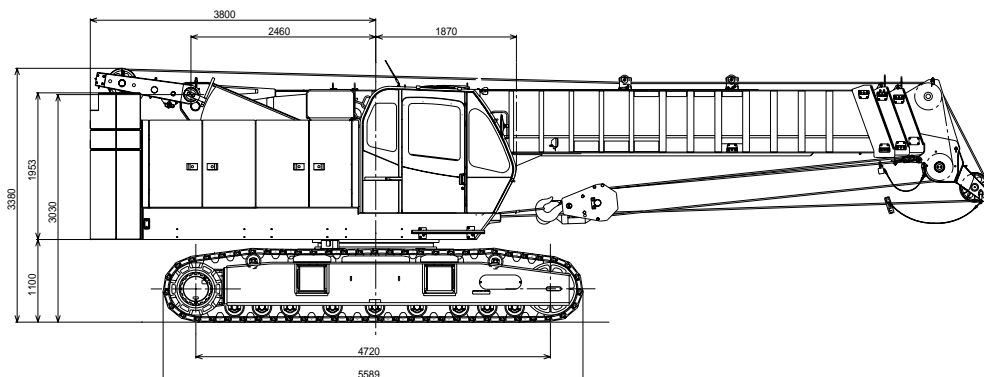

KOBELCO CONSTRUCTION MACHINERY CO., LTD.

LIFTING CAPACITY

Rated loads in metric tons for 360° area with 12.0 ton counterweight

Unit: metric ton

Boom length (m)	9.97	16.7	23.4	30.1	Boom length (m)
3.0	55.00	28.00	22.00	14.00	3.0
3.5	50.00	28.00	22.00	14.00	3.5
4.0	42.50	28.00	22.00	14.00	4.0
4.5	36.50	28.00	22.00	14.00	4.5
5.0	31.65	28.00	22.00	14.00	5.0
5.5	26.90	26.65	22.00	14.00	5.5
6.0	23.35	23.10	22.00	14.00	6.0
6.5	20.55	20.30	20.15	14.00	6.5
7.0	18.25	18.00	17.85	13.50	7.0
7.5	12.50	16.15	16.00	13.00	7.5
8.0		14.60	14.45	12.50	8.0
8.5		13.30	13.15	12.00	8.5
9.0		12.30	12.00	11.50	9.0
9.5		11.25	11.00	11.00	9.5
10.0		10.40	10.15	10.70	10.0
11.0		9.00	8.70	9.20	11.0
12.0		7.80	7.55	8.05	12.0
13.0		6.80	6.60	7.10	13.0
14.0		6.00	5.80	6.25	14.0
14.2		5.80	5.65	6.10	14.2
15.0			5.10	5.60	15.0
16.0			4.55	5.00	16.0
17.0			4.05	4.50	17.0
18.0			3.60	4.05	18.0
19.0			3.25	3.65	19.0
20.0			2.90	3.30	20.0
20.9			2.60	3.05	20.9
22.0				2.75	22.0
24.0				2.20	24.0
26.0				1.75	26.0
27.6				1.45	27.6
Min. boom angle	0°	0°	0°	0°	Min. boom angle

LIFTING CAPACITY

Rated loads in metric tons for 360° area with 8.0 ton counterweight (Optional setting)

Unit: metric ton

Boom length (m)	9.97	16.7	23.4	30.1	Boom length (m)
3.0	55.00	28.00	22.00	14.00	3.0
3.5	50.00	28.00	22.00	14.00	3.5
4.0	40.45	28.00	22.00	14.00	4.0
4.5	32.25	28.00	22.00	14.00	4.5
5.0	26.70	26.45	22.00	14.00	5.0
5.5	22.65	22.40	22.00	14.00	5.5
6.0	19.55	19.35	19.15	14.00	6.0
6.5	17.15	16.95	16.75	14.00	6.5
7.0	15.25	15.00	14.85	13.50	7.0
7.5	12.50	13.35	13.20	13.00	7.5
8.0		12.05	11.90	12.50	8.0
8.5		10.95	10.80	11.35	8.5
9.0		9.95	9.80	10.40	9.0
9.5		9.10	8.95	9.50	9.5
10.0		8.35	8.20	8.75	10.0
11.0		7.15	7.00	7.50	11.0
12.0		6.15	6.00	6.50	12.0
13.0		5.35	5.20	5.70	13.0
14.0		4.65	4.50	5.00	14.0
14.2		4.55	4.40	4.85	14.2
15.0			3.95	4.40	15.0
16.0			3.45	3.90	16.0
17.0			3.00	3.45	17.0
18.0			2.60	3.10	18.0
19.0			2.25	2.75	19.0
20.0			1.90	2.45	20.0
20.9			1.65	2.15	20.9
22.0				1.85	22.0
24.0				1.35	24.0
26.0				1.00	26.0
27.6				0.75	27.6
Min. boom angle	0°	0°	0°	0°	Min. boom angle

LIFTING CAPACITY

Rated loads in metric tons for 360° area without counterweight (Optional setting)

Unit: metric ton

Boom length (m)	9.97	16.7
3.0	18.00	18.00
3.5	18.00	18.00
4.0	18.00	18.00
4.5	18.00	18.00
5.0	16.30	16.10
5.5	13.70	13.50
6.0	11.70	11.50
6.5	10.20	9.90
7.0	8.90	8.70
7.5	7.90	7.60
8.0		6.80
8.5		6.00
9.0		5.40
9.5		4.80
10.0		4.40
11.0		3.60
12.0		3.00
13.0		2.40
14.0		1.90
14.2		1.80
Min. boom angle	0°	0°

WORKING RANGES

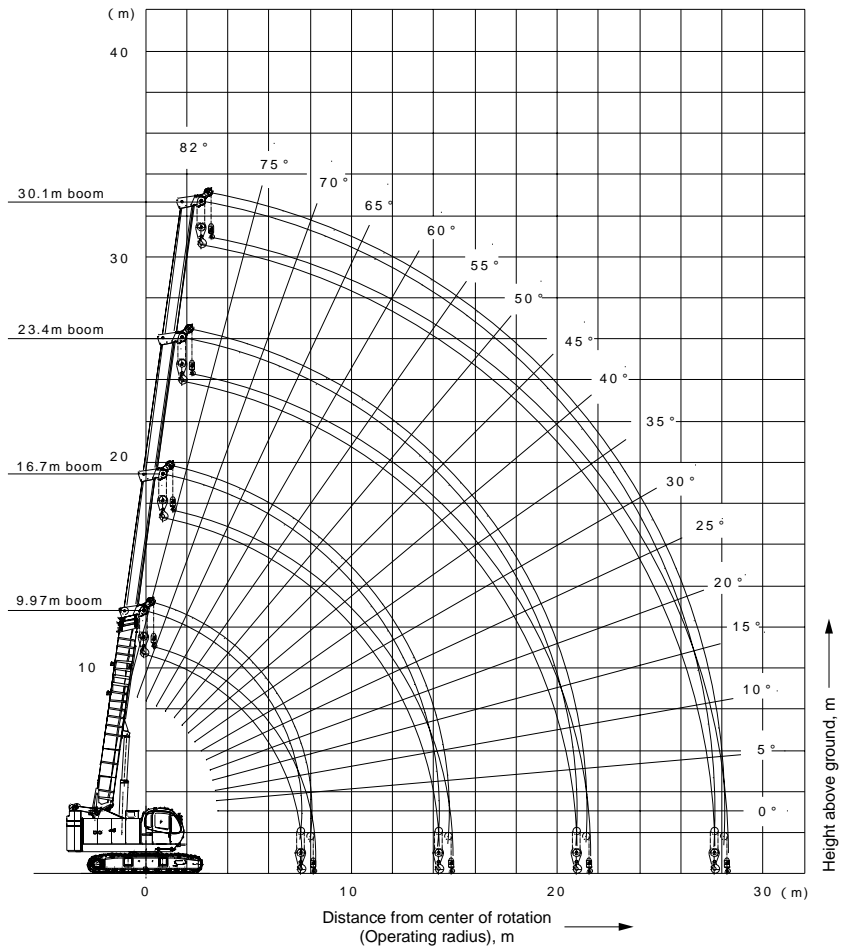

Notes:

1. Rated load do not exceed 78% of the tipping loads with machine set horizontally on a firm and level ground, satisfy the specified stability over the front, and include weight of hook block(s) and other handling accessories. Ratings shown in are based on the machine's structural strength, and others are determined by the machine's stability.

Hooks	55-ton	25-ton	5-ton	5-ton (ball hook)
Weight	400 kg	300 kg	90 kg	40 kg

Note: 5-ton ball hook is option.

2. Rated loads shown are based on freely suspended loads and make no allowance for such factors as wind effect on lifted load, ground conditions out-of-level. Operating speeds or any other condition that could be detrimental to the safe operation of this equipment, the operator, therefore, has the responsibility to judge the existing conditions and reduce lifted loads and operating speeds accordingly.

3. Operating radius is the horizontal distance from centerline of rotation to a vertical line through the center of gravity the load. Operating radius given in the charts allow for loaded boom deflection. Always operate the machine on the basis of actual operating radius.

4. Both crawlers should be fully extended.

5. The ratings of the auxiliary sheave are the same as the main boom ratings, but should not exceed 5,000 kg. Ratings of the auxiliary sheave are calculated by deducting from the main boom ratings 55 ton hook weight (400 kg) with the main boom extended ranging from 9.97 m to 16.7 m, and 25 ton hook weight (500 kg) with the main boom extended over 16.7m up to its maximum length.

6. To determine load ratings that fall between those shown in the charts, proceed as follows:

- For boom lengths not listed use rating for next longer boom length or next shorter boom length, whichever is smaller.
- For load radii not shown, use rating for next larger radius.

7. At radii and boom lengths where no ratings are shown on chart, operation is not intended or approved.

8. Standard hoist reevings are shown bellow. Rated single-line pull must not exceed 4,500 kg.

Boom length	9.97 m	16.7 m	23.4 m	30.1 m
Hook	55-ton		25-ton	
No. of reeving	12	6	5	4

9. In order to prevent a load from falling down to mistake of operation, do not use free-fall in crane operation.

STANDARD EQUIPMENT

Upper structure/Lower structure
Counterweight: 12.0 ton (8.0 ton + 1.7 ton + 2.3 ton)
760 mm shoe crawlers
170F51 battery
Electric hand throttle grip
Side deck (for cab): 300 mm (W) x 970 mm (L)
Step (equipped on left-side guard)
Anti-slip sheet
Step (equipped on crawlers)
Tools (for routine maintenance)
Lubrication device
Tool box (equipped on right-side guard)
Three front working lights
Two back mirrors
Cab
Air conditioner
Convenient compartment
Cup holder
AM/FM Radio
Ashtray
Cigarette lighter
Intermittent windshield wiper with window washer (roof, front and lower front window)
Sun visor
Roof blind
Tinted glass
Floor mat (cloth)
Foot pedal cover (rubber)
Shoe tray
Safety Device
Over-load prevention device (auto stop function)
Release prevention key for hook over-hoist prevention device
LCD Multi-display (shows gauges and warning signs)
Hook over-hoist auto-stop device
Safety lever lock
Lever lock switch (main, aux., boom hoist, and telescoping)
Propel lever lock
Manual drum safety pawl (main, aux. and boom hoist)
Negative brake in lever neutral-position
Service brake pedal lock (main, aux.)
Lamp for neutral-free/brake select switch (main, aux.)
Neutral-free/brake select switch (main, aux.)
Counterweight detection device
Neutral brake release prevention key (main, aux.)
Brake activating device for engine stop
Hydraulically safety valve
Boom telescoping default operation prevention device
Winch protection device
Propel protection device
Sling wire lock
Swing lock pin
Swing flashers
Swing warning buzzer
Level gauge

OPTIONAL EQUIPMENT

Third drum: wire rope 16 dia. X 80 m, with free-fall
4-spool valve: Max. discharge pressure 17.2 MPa (175 kgf/cm ²) Max. discharge flow 40 lites/min
Outlet for Vibro: Max. output 50 kW (68 PS) Max. discharge pressure 27.5 MPa (280 kgf/cm ²) Max. discharge flow 110 lites/min
No.1 Outlet for Auger: Max. output 78/45 kW (106/61 PS) Max. discharge pressure 24.5 MPa (250 kgf/cm ²) Max. discharge flow 190/110 lites/min (with oil flow select switch)
No.2 Outlet for Auger: Max. output 93/50 kW (126/68 PS) Max. discharge pressure 24.5 MPa (250 kgf/cm ²) Max. discharge flow 300/150 lites/min (with oil flow select switch)
Hydraulic tagline: 10 dia. x 45 m
Lifting capacity set: without counterweight
Swing neutral brake: cannot select swing neutral free
5-ton light hook: 40 kg
Wire rope loose prevention device (main, aux., third)
Counterweight self-removal device
Foot acceleration: right hand
Boom hoist pedal: left hand (not available to equip with third-drum specs)
Boom hoist pedal: right hand (not available to equip with foot acceleration)
Engine rpm fix switch: 4-steps
Cab roof guard
Cab front upper/lower guard
Side catwalk (without handrail): 300 mm (W) x 3,330 mm (L) — right hand/ 4,090 mm (L) — left hand
Color monitoring camera (backward)
Monitoring camera for main/aux. with lighting
Overload alarm lamp (3 colors, square shape)
Voice alarm for travel /swing
Electric fuel pump
Tool box (equipped in lower frame): not available to equip with TransLifter simultaneously
Fire extinguisher
Electric fan

Note: Due to our policy of continual product improvements all designs and specifications are subject to change without advance notice.

KOBELCO CONSTRUCTION MACHINERY CO., LTD.

17-1, Higashi-Gotanda 2-chome, Shinagawa-ku, TOKYO, 141-8626 JAPAN
Tel: ++81 (0) 3-5789-2121 Fax: ++81 (0) 3-5789-2134