

TEREX MODEL T 550 50 TON CAPACITY

range diagram & lifting capacities

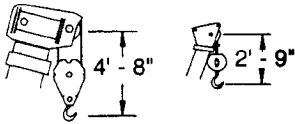

DIMENSIONS ARE FOR LARGEST FACTORY FURNISHED HOOK BLOCK AND HOOK & BALL, WITH ANTI-TWO BLOCK ACTIVATED

Range Diagram (35' - 110' boom)

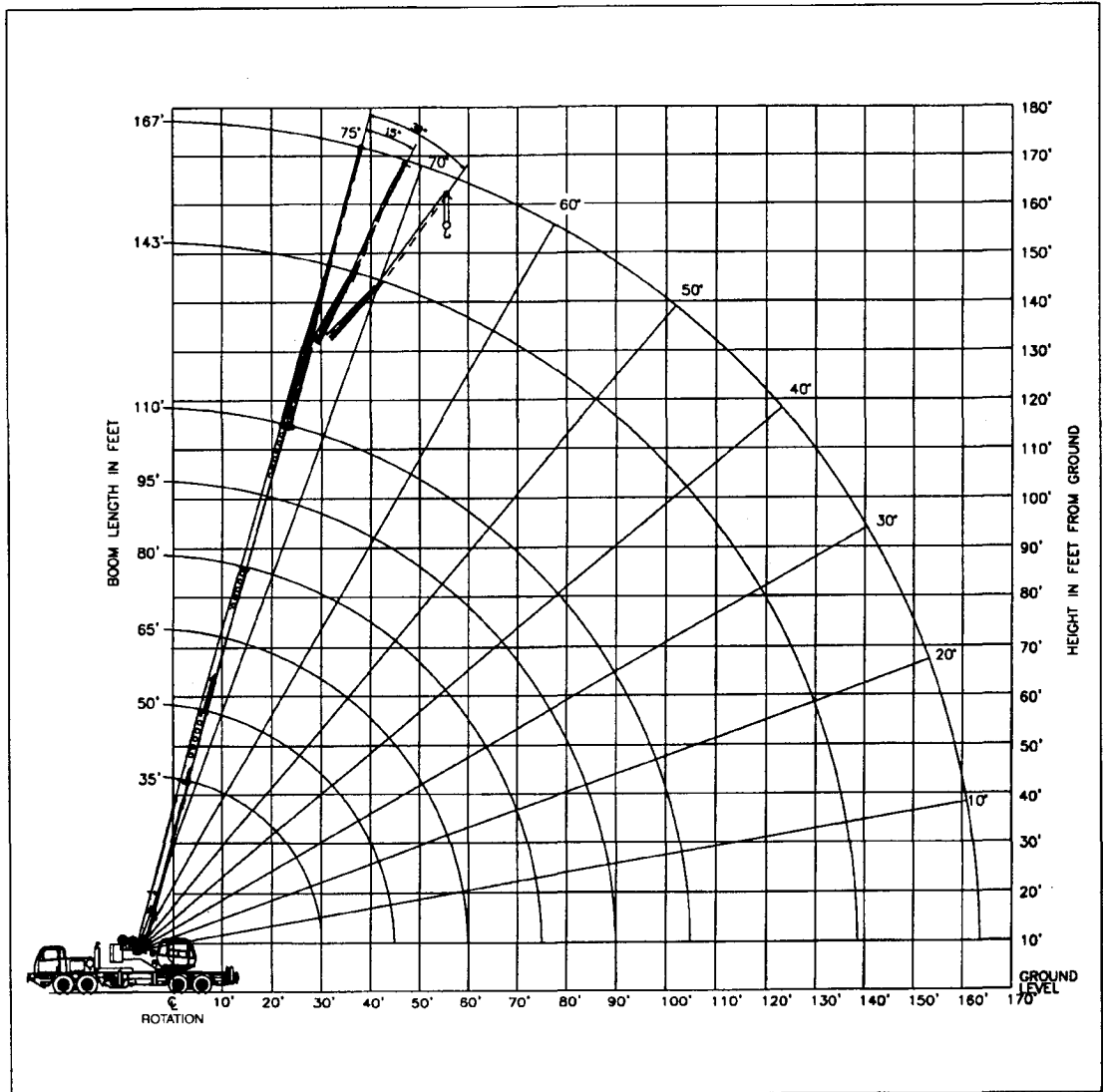

CRANE WORKING CONDITIONS

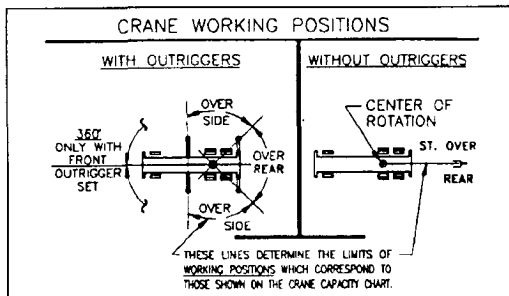

REDUCTION IN MAIN BOOM CAPACITY

All Jibs in Stowed Position _____ 0 Lbs.
 Aux. Boom in Head Sheave _____ 100 Lbs.

HOOK BLOCK WEIGHTS

Hook & Ball _____ 239 Lbs.
 40T Hook Block (4 Sheave) _____ 690 Lbs.
 50T Hook Block (5 Sheave) _____ 888 Lbs.
 50T Hook Block (6 Sheave) _____ 913 Lbs.

Lifting Capacities – Pounds (35' – 110' boom)

MODEL T 550

COUNTERWEIGHT:
UPPER:
W/AUX. WINCH 9900 LBS.
W/O AUX. WINCH 11000 LBS.

BOOM LENGTH 35-110 FT.
STABILITY PERCENTAGE:
ON OUTRIGGERS 85%
ON TIRES 75%
PCSA CLASS 12-196

CAUTION: Do not use this specification sheet as a load rating chart. The format of data is not consistent with the machine chart and may be subject to change.

ON OUTRIGGERS - FULLY EXTENDED AND WITH 11000 LB. COUNTERWEIGHT

LOAD RADIUS (FT)	BOOM LENGTH 35 FT			BOOM LENGTH 50 FT			BOOM LENGTH 65 FT			LOAD RADIUS (FT)
	LOADED BOOM ANGLE (DEG)	OVER REAR (LB)	360° (LB)	LOADED BOOM ANGLE (DEG)	OVER REAR (LB)	360° (LB)	LOADED BOOM ANGLE (DEG)	OVER REAR (LB)	360° (LB)	
10	66.7	100,000*	100,000*	73.9	60,100*	60,100*				10
12	63.1	100,000*	100,000*	71.5	60,100*	60,100*				12
15	57.5	83,400*	83,400*	67.9	60,100*	60,100*	73.2	58,800*	58,800*	15
20	47.1	60,200*	60,200*	61.5	60,100*	60,100*	68.5	52,200*	52,200*	20
25	34.5	46,100*	46,100*	54.8	47,500*	47,500*	63.7	46,900*	46,900*	25
30	14.8	36,600*	32,000*	47.4	38,100*	33,900*	58.6	38,700*	34,400*	30
35	**			39.0	31,300*	25,300*	53.3	32,000*	25,900*	35
40				28.8	26,100*	19,600*	47.6	26,800*	20,300*	40
45				12.4	21,000*	15,400*	41.3	21,900*	16,300*	45
50					**		34.1	18,200*	13,200*	50
55							25.2	15,300*	10,800*	55
60							10.9	13,000*	8,800*	60
65										65
70										70
75										75
80										80
85										85
90										90
95										95

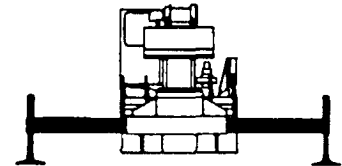

**USE THESE CHARTS ONLY
WHEN ALL OUTRIGGERS
ARE FULLY EXTENDED**

ON OUTRIGGERS - FULLY EXTENDED AND WITH 11000 LB. COUNTERWEIGHT

LOAD RADIUS (FT)	BOOM LENGTH 80 FT			BOOM LENGTH 95 FT			BOOM LENGTH 110 FT			LOAD RADIUS (FT)
	LOADED BOOM ANGLE (DEG)	OVER REAR (LB)	360° (LB)	LOADED BOOM ANGLE (DEG)	OVER REAR (LB)	360° (LB)	LOADED BOOM ANGLE (DEG)	OVER REAR (LB)	360° (LB)	
10										10
12										12
15										15
20	72.7	38,700*	38,700*							20
25	68.9	33,600*	33,600*	72.3	29,300*	29,300*				25
30	65.0	29,600*	29,600*	69.1	25,900*	25,900*	72.1	22,900*	22,900*	30
35	61.0	26,500*	26,200*	65.9	23,000*	23,000*	69.3	20,500*	20,500*	35
40	56.8	23,900*	20,600*	62.5	20,800*	20,800*	66.5	18,400*	18,400*	40
45	52.4	21,800*	16,600*	59.1	18,900*	16,800*	63.6	16,500*	16,500*	45
50	47.7	18,600*	13,600*	55.5	17,300*	13,800*	60.7	14,900*	13,900*	50
55	42.7	15,800*	11,300*	51.7	15,900*	11,500*	57.7	13,500*	11,600*	55
60	37.1	13,500*	9,400*	47.8	13,700*	9,600*	54.5	12,300*	9,700*	60
65	30.6	11,600*	7,800*	43.6	11,900*	8,100*	51.3	11,200*	8,200*	65
70	22.6	10,000*	6,500*	39.0	10,300*	6,800*	47.8	10,300*	6,900*	70
75	9.8	8,600*	5,300*	33.9	9,000*	5,700*	44.2	9,200*	5,900*	75
80	**			28.1	7,900*	4,700*	40.4	8,100*	5,000*	80
85				20.8	6,800*	3,900*	36.1	7,100*	4,100*	85
90				9.0	5,900*	3,100*	31.5	6,200*	3,400*	90
95				**			26.0	5,400*	2,800*	95
100							19.3	4,700*	2,200*	100
105							8.4	4,100*	1,700*	105

** MAXIMUM CAPACITY AT 0 DEGREE BOOM ANGLE

BOOM LENGTH 35 FT			BOOM LENGTH 50 FT			BOOM LENGTH 65 FT			BOOM LENGTH 80 FT			BOOM LENGTH 95 FT			BOOM LENGTH 110 FT		
BOOM LOAD RADIUS (FT)	OVER REAR (LB)	360° (LB)	BOOM LOAD RADIUS (FT)	OVER REAR (LB)	360° (LB)	BOOM LOAD RADIUS (FT)	OVER REAR (LB)	360° (LB)	BOOM LOAD RADIUS (FT)	OVER REAR (LB)	360° (LB)	BOOM LOAD RADIUS (FT)	OVER REAR (LB)	360° (LB)	BOOM LOAD RADIUS (FT)	OVER REAR (LB)	360° (LB)
31.2	21,000*	21,000*	46.2	12,800*	12,800*	61.2	8,400*	8,300	76.2	5,600*	5,000	91.2	3,700*	2,900	106.17	2,400*	1,500

Lifting Capacities – Pounds (35' – 110' boom)

MODEL T 550

COUNTERWEIGHT:
UPPER:
W/AUX. WINCH 9900 LBS.
W/O AUX. WINCH 11000
LBS.

BOOM LENGTH 35-110 FT.
STABILITY PERCENTAGE
ON OUTRIGGERS 85%
ON TIRES 75%
PCSA CLASS 12-196

CAUTION: Do not use this specification sheet as a load rating chart. The format of data is not consistent with the machine chart and may be subject to change.

ON OUTRIGGERS - MID POSITION AND WITH 11000 LB. COUNTERWEIGHT

LOAD RADIUS (FT)	BOOM LENGTH 35 FT		BOOM LENGTH 50 FT		BOOM LENGTH 65 FT		BOOM LENGTH 80 FT		BOOM LENGTH 95 FT		BOOM LENGTH 110 FT		LOAD RADIUS (FT)	
	LOADED BOOM ANGLE (DEG)	360° (LB)	LOADED BOOM ANGLE (DEG)	360° (LB)	LOADED BOOM ANGLE (DEG)	360° (LB)	LOADED BOOM ANGLE (DEG)	360° (LB)	LOADED BOOM ANGLE (DEG)	360° (LB)	LOADED BOOM ANGLE (DEG)	360° (LB)		
10	66.7	100,000*	73.9	60,100*									10	
12	63.1	92,500*	71.5	60,100*									12	
15	57.5	61,700	67.9	60,100*	73.2	58,800*							15	
20	47.1	34,200	61.5	35,500	68.5	36,100	72.7	36,500					20	
25	34.5	21,900	54.8	23,400	63.7	23,900	68.9	24,300	72.3	24,500			25	
30	14.8	14,900	47.4	16,500	58.6	17,100	65.0	17,400	69.1	17,600	72.1	17,700	30	
35	**		39.0	12,000	53.3	12,700	61.0	13,000	65.9	13,200	69.3	13,300	35	
40			28.8	8,900	47.6	9,600	56.8	10,000	62.5	10,100	66.5	10,300	40	
45			12.4	6,500	41.3	7,300	52.4	7,700	59.1	7,900	63.6	8,000	45	
50			**		34.1	5,500	47.7	5,900	55.5	6,200	60.7	6,300	50	
55					25.2	4,100	42.7	4,500	51.7	4,800	57.7	4,900	55	
60					10.9	2,800	37.1	3,400	47.8	3,600	54.5	3,800	60	
65					**			30.6	2,400	43.6	2,700	51.3	2,900	65
70								22.6	1,600	39.0	1,900	47.8	2,100	70
75										33.9	1,200	44.2	1,400	75

** MAXIMUM CAPACITY AT 0 DEGREE BOOM ANGLE

BOOM LENGTH 35 FT		BOOM LENGTH 50 FT		BOOM LENGTH 65 FT		BOOM LENGTH 80 FT		BOOM LENGTH 95 FT		BOOM LENGTH 110 FT	
LOAD RADIUS (FT)	360° (LB)	LOAD RADIUS (FT)	360° (LB)	LOAD RADIUS (FT)	360° (LB)	LOAD RADIUS (FT)	360° (LB)	LOAD RADIUS (FT)	360° (LB)	LOAD RADIUS (FT)	360° (LB)
31.2	13,400	46.2	5,900	61.2	2,500						

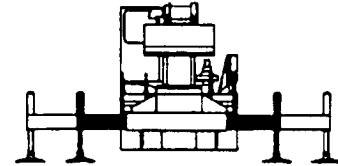

USE THESE CHARTS ONLY WHEN ALL OUTRIGGERS ARE PINNED IN MID POSITION

ON OUTRIGGERS - RETRACTED AND WITH 11000 LB. COUNTERWEIGHT

LOAD RADIUS (FT)	BOOM LENGTH 35 FT		BOOM LENGTH 50 FT		BOOM LENGTH 65 FT		BOOM LENGTH 80 FT		BOOM LENGTH 95 FT		BOOM LENGTH 110 FT		LOAD RADIUS (FT)
	LOADED BOOM ANGLE (DEG)	360° (LB)	LOADED BOOM ANGLE (DEG)	360° (LB)	LOADED BOOM ANGLE (DEG)	360° (LB)	LOADED BOOM ANGLE (DEG)	360° (LB)	LOADED BOOM ANGLE (DEG)	360° (LB)	LOADED BOOM ANGLE (DEG)	360° (LB)	
10	66.7	51,200	73.9	52,400									10
12	63.1	36,600	71.5	37,700									12
15	57.5	24,400	67.9	25,600	73.2	26,100							15
20	47.1	14,000	61.5	15,300	68.5	15,800	72.7	16,100					20
25	34.5	8,400	54.8	9,800	63.7	10,400	68.9	10,700	72.3	10,800			25
30	14.8	4,900	47.4	6,300	58.6	7,000	65.0	7,300	69.1	7,500	72.1	7,600	30
35	**		39.0	4,000	53.3	4,600	61.0	5,000	65.9	5,200	69.3	5,200	35
40			28.8	2,200	47.6	2,900	56.8	3,300	62.5	3,500	66.5	3,600	40
45					41.3	1,600	52.4	2,000	59.1	2,200	63.6	2,400	45
50									55.5	1,200	60.7	1,400	50

** MAXIMUM CAPACITY AT 0 DEGREE BOOM ANGLE

BOOM LENGTH 35 FT		BOOM LENGTH 50 FT		BOOM LENGTH 65 FT		BOOM LENGTH 80 FT		BOOM LENGTH 95 FT		BOOM LENGTH 110 FT	
LOAD RADIUS (FT)	360° (LB)	LOAD RADIUS (FT)	360° (LB)	LOAD RADIUS (FT)	360° (LB)	LOAD RADIUS (FT)	360° (LB)	LOAD RADIUS (FT)	360° (LB)	LOAD RADIUS (FT)	360° (LB)
31.2	4,000										

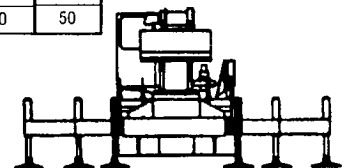

USE THESE CHARTS WHEN ALL OUTRIGGER BEAMS ARE NOT IN EITHER THE MID OR FULLY EXTENDED POSITION

Lifting Capacities – Pounds (35' – 110' boom)

MODEL T 550

COUNTERWEIGHT:
UPPER:
W/AUX. WINCH 6900 LBS.
W/O AUX. WINCH 8000 LBS.

BOOM LENGTH 35-110 FT.
STABILITY PERCENTAGE
ON OUTRIGGERS 85%
ON TIRES 75%
PCSA CLASS 12-173

CAUTION: Do not use this specification sheet as a load rating chart. The format of data is not consistent with the machine chart and may be subject to change.

ON OUTRIGGERS - FULLY EXTENDED AND WITH 8000 LB. COUNTERWEIGHT

LOAD RADIUS (FT)	BOOM LENGTH 35 FT			BOOM LENGTH 50 FT			BOOM LENGTH 65 FT			LOAD RADIUS (FT)
	LOADED BOOM ANGLE (DEG)	OVER REAR (LB)	360° (LB)	LOADED BOOM ANGLE (DEG)	OVER REAR (LB)	360° (LB)	LOADED BOOM ANGLE (DEG)	OVER REAR (LB)	360° (LB)	
10	66.7	100,000*	100,000*	73.9	60,100*	60,100*				10
12	63.1	100,000*	100,000*	71.5	60,100*	60,100*				12
15	57.5	81,400*	81,400*	67.9	60,100*	60,100*	73.2	58,800*	58,800*	15
20	47.1	58,700*	58,700*	61.5	59,900*	59,900*	68.5	52,200*	52,200*	20
25	34.5	44,900*	41,900	54.8	46,200*	43,400	63.7	46,900*	44,100	25
30	14.8	35,500*	28,500	47.4	37,000*	30,300	58.6	37,700*	30,900	30
35	**			39.0	30,400*	22,500	53.3	31,100*	23,100	35
40				28.8	24,400	17,200	47.6	25,200	17,900	40
45				12.4	19,600	13,300	41.3	20,500	14,200	45
50				**			34.1	17,000	11,400	50
55							25.2	14,200	9,200	55
60							10.9	11,900	7,400	60
65							**			65
70										70
75										75
80										80
85										85
90										90
95										95
100										100
105										105

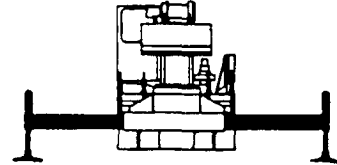

**USE THESE CHARTS ONLY
WHEN ALL OUTRIGGERS
ARE FULLY EXTENDED**

ON OUTRIGGERS - FULLY EXTENDED AND WITH 8000 LB. COUNTERWEIGHT

LOAD RADIUS (FT)	BOOM LENGTH 80 FT			BOOM LENGTH 95 FT			BOOM LENGTH 110 FT			LOAD RADIUS (FT)
	LOADED BOOM ANGLE (DEG)	OVER REAR (LB)	360° (LB)	LOADED BOOM ANGLE (DEG)	OVER REAR (LB)	360° (LB)	LOADED BOOM ANGLE (DEG)	OVER REAR (LB)	360° (LB)	
10										10
12										12
15										15
20	72.7	38,700*	38,700*							20
25	68.9	33,600*	33,600*	72.3	29,300*	29,300*				25
30	65.0	29,600*	29,600*	69.1	25,900*	25,900*	72.1	22,900*	22,900*	30
35	61.0	26,500*	23,400	65.9	23,000*	23,000*	69.3	20,500*	20,500*	35
40	56.8	23,900*	18,200	62.5	20,800*	18,400	66.5	18,400*	18,400*	40
45	52.4	20,800	14,600	59.1	18,900*	14,800	63.6	16,500*	14,900	45
50	47.7	17,400	11,800	55.5	17,300*	12,000	60.7	14,900*	12,100	50
55	42.7	14,600	9,700	51.7	14,800	9,900	57.7	13,500*	10,000	55
60	37.1	12,400	7,900	47.8	12,700	8,200	54.5	12,300*	8,300	60
65	30.6	10,600	6,500	43.6	10,900	6,800	51.3	11,000	6,900	65
70	22.6	9,100	5,300	39.0	9,400	5,600	47.8	9,600	5,700	70
75	9.8	7,800	4,200	33.9	8,100	4,600	44.2	8,300	4,800	75
80	**			28.1	7,000	3,700	40.4	7,200	3,900	80
85				20.8	6,100	2,900	36.1	6,300	3,200	85
90				9.0	5,200	2,200	31.5	5,500	2,500	90
95				**			26.0	4,700	1,900	95
100							19.3	4,000	1,400	100
105							8.4	3,400	900	105

** MAXIMUM CAPACITY AT 0 DEGREE BOOM ANGLE

BOOM LOAD RADIUS (FT)	BOOM LENGTH 35 FT			BOOM LENGTH 50 FT			BOOM LENGTH 65 FT			BOOM LENGTH 80 FT			BOOM LENGTH 95 FT			BOOM LENGTH 110 FT		
	OVER REAR (LB)	360° (LB)	BOOM LOAD RADIUS (FT)	OVER REAR (LB)	360° (LB)	BOOM LOAD RADIUS (FT)	OVER REAR (LB)	360° (LB)	BOOM LOAD RADIUS (FT)	OVER REAR (LB)	360° (LB)	BOOM LOAD RADIUS (FT)	OVER REAR (LB)	360° (LB)	BOOM LOAD RADIUS (FT)	OVER REAR (LB)	360° (LB)	
31.2	21,000*	21,000*	46.2	12,800*	12,500*	61.2	8,400	6,900	76.2	5,600*	3,900	91.2	3,700*	2,000	106.17	2,400*	700	

Lifting Capacities – Pounds (35'– 110' boom)

MODEL T 550

COUNTERWEIGHT:
UPPER:
W/AUX. WINCH 3900 LBS.
W/O AUX. WINCH 5000 LBS.

BOOM LENGTH 35-110 FT.
STABILITY PERCENTAGE
ON OUTRIGGERS 85%
ON TIRES 75%
PCSA CLASS 12-196

CAUTION: Do not use this specification sheet as a load rating chart. The format of data is not consistent with the machine chart and may be subject to change.

ON OUTRIGGERS - FULLY EXTENDED AND WITH 5000 LB. COUNTERWEIGHT

LOAD RADIUS (FT)	BOOM LENGTH 35 FT			BOOM LENGTH 50 FT			BOOM LENGTH 65 FT			LOAD RADIUS (FT)
	LOADED BOOM ANGLE (DEG)	OVER REAR (LB)	360° (LB)	LOADED BOOM ANGLE (DEG)	OVER REAR (LB)	360° (LB)	LOADED BOOM ANGLE (DEG)	OVER REAR (LB)	360° (LB)	
10	66.7	100,000*	100,000*	73.9	60,100*	60,100*				10
12	63.1	100,000*	100,000*	71.5	60,100*	60,100*				12
15	57.5	79,300*	79,300*	67.9	60,100*	60,100*	73.2	58,800*	58,800*	15
20	47.1	57,000*	57,000*	61.5	58,400*	58,400*	68.5	52,200*	52,200*	20
25	34.5	43,600*	37,600*	54.8	44,900*	40,000*	63.7	45,600*	39,700*	25
30	14.8	34,400*	25,300*	47.4	35,900*	27,100*	58.6	36,600*	27,700*	30
35	**			39.0	29,100*	20,000*	53.3	29,700*	20,600*	35
40				28.8	22,700*	15,200*	47.6	23,500*	15,900*	40
45				12.4	18,100*	11,600*	41.3	19,100*	12,500*	45
50				**			34.1	15,700*	10,000*	50
55							25.2	13,000*	7,900*	55
60							10.9	10,800*	6,200*	60
65							**			65
70										70
75										75
80										80
85										85
90										90
95										95
100										100
105										105

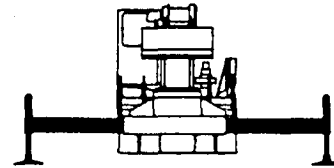

**USE THESE CHARTS ONLY
WHEN ALL OUTRIGGERS
ARE FULLY EXTENDED**

ON OUTRIGGERS - FULLY EXTENDED AND WITH 5000 LB. COUNTERWEIGHT

LOAD RADIUS (FT)	BOOM LENGTH 80 FT			BOOM LENGTH 95 FT			BOOM LENGTH 110 FT			LOAD RADIUS (FT)
	LOADED BOOM ANGLE (DEG)	OVER REAR (LB)	360° (LB)	LOADED BOOM ANGLE (DEG)	OVER REAR (LB)	360° (LB)	LOADED BOOM ANGLE (DEG)	OVER REAR (LB)	360° (LB)	
10										10
12										12
15										15
20	72.7	38,700*	38,700*							20
25	68.9	33,600*	33,600*	72.3	29,300*	29,300*				25
30	65.0	30,000*	28,100*	69.1	25,900*	25,900*	72.1	22,900*	22,900*	30
35	61.0	26,500*	20,900*	65.9	23,000*	21,200*	69.3	20,500*	20,500*	35
40	56.8	23,800*	16,200*	62.5	20,800*	16,400*	66.5	18,400*	16,600*	40
45	52.4	19,400*	12,900*	59.1	18,900*	13,100*	63.6	16,500*	13,200*	45
50	47.7	16,100*	10,400*	55.5	16,300*	10,600*	60.7	14,900*	10,700*	50
55	42.7	13,500*	8,400*	51.7	13,700*	8,600*	57.7	13,500*	8,700*	55
60	37.1	11,400*	6,800*	47.8	11,600*	7,000*	54.5	11,800*	7,200*	60
65	30.6	9,600*	5,500*	43.6	9,900*	5,800*	51.3	10,100*	5,900*	65
70	22.6	8,200*	4,400*	39.0	8,500*	4,700*	47.8	8,700*	4,800*	70
75	9.8	6,900*	3,400*	33.9	7,300*	3,800*	44.2	7,500*	3,900*	75
80	**			28.1	6,200*	3,000*	40.4	6,400*	3,200*	80
85				20.8	5,300*	2,200*	36.1	5,500*	2,500*	85
90				9.0	4,500*	1,600*	31.5	4,700*	1,900*	90
95				**			26.0	4,000*	1,300*	95
100							19.3	3,400*	800*	100
105							8.4	2,800*		105

** MAXIMUM CAPACITY AT 0 DEGREE BOOM ANGLE

BOOM LENGTH 35 FT			BOOM LENGTH 50 FT			BOOM LENGTH 65 FT			BOOM LENGTH 80 FT			BOOM LENGTH 95 FT			BOOM LENGTH 110 FT		
BOOM LOAD RADIUS (FT)	OVER REAR (LB)	360° (LB)	BOOM LOAD RADIUS (FT)	OVER REAR (LB)	360° (LB)	BOOM LOAD RADIUS (FT)	OVER REAR (LB)	360° (LB)	BOOM LOAD RADIUS (FT)	OVER REAR (LB)	360° (LB)	BOOM LOAD RADIUS (FT)	OVER REAR (LB)	360° (LB)	BOOM LOAD RADIUS (FT)	OVER REAR (LB)	360° (LB)
31.2	20,900*	20,900*	46.2	12,700*	10,800*	61.2	8,300*	5,800*	76.2	5,600*	3,100*	91.2	3,700*	1,400*	106.17	2,300*	

Lifting Capacities – Pounds (35'– 110' boom)

MODEL T 550

COUNTERWEIGHT:
UPPER:
W/AUX. WINCH 9900 LBS.
W/O AUX. WINCH 11000 LBS.

BOOM LENGTH 35-110 FT.
STABILITY PERCENTAGE
ON OUTRIGGERS 85%
ON TIRES 75%
PCSA CLASS 12-196

CAUTION: Do not use this specification sheet as a load rating chart. The format of data is not consistent with the machine chart and may be subject to change.

SIDE STOW JIB ON FULLY EXTENDED OUTRIGGERS WITH 11000 LB. COUNTERWEIGHT

LOADED BOOM ANGLE (DEG)	33 FT OFFSETTABLE JIB									57 FT OFFSETTABLE JIB									LOADED BOOM ANGLE (DEG)
	0° OFFSET			15° OFFSET			30° OFFSET			0° OFFSET			15° OFFSET			30° OFFSET			
	(REF) LOAD RADIUS (FT)	REAR ONLY (LB)	360° (LB)	(REF) LOAD RADIUS (FT)	REAR ONLY (LB)	360° (LB)	(REF) LOAD RADIUS (FT)	REAR ONLY (LB)	360° (LB)	(REF) LOAD RADIUS (FT)	REAR ONLY (LB)	360° (LB)	(REF) LOAD RADIUS (FT)	REAR ONLY (LB)	360° (LB)	(REF) LOAD RADIUS (FT)	REAR ONLY (LB)	360° (LB)	
75	42	12,600*	12,600*	49	8,500*	8,500*	56	6,600*	6,600*	50	6,600*	6,600*	64	4,600*	4,600*	74	3,400*	3,400*	75
73	47	11,900*	11,900*	54	8,200*	8,200*	69	6,400*	6,400*	56	6,200*	6,200*	69	4,400*	4,400*	79	3,300*	3,300*	73
71	53	11,300*	11,300*	59	7,800*	7,800*	65	6,300*	6,300*	62	5,900*	5,900*	75	4,200*	4,200*	85	3,200*	3,200*	71
68	60	10,400*	9,900*	66	7,400*	7,400*	71	6,000*	6,000*	70	5,600*	5,600*	82	3,900*	3,900*	91	3,100*	3,100*	68
65	67	9,600*	8,300*	72	7,100*	7,100*	77	5,900*	5,900*	78	5,200*	5,200*	90	3,700*	3,700*	97	3,000*	3,000*	65
62	73	8,900*	6,800*	78	6,800*	6,100*	83	5,700*	5,700*	86	4,800*	4,800*	97	3,500*	3,500*	104	2,900*	2,900*	62
59	80	8,300*	5,700*	84	6,500*	5,100*	89	5,500*	4,900*	95	4,500*	4,400*	104	3,400*	3,300*	110	2,800*	2,800*	59
55	87	6,900*	4,500*	91	6,200*	4,200*	96	5,300*	4,000*	105	4,100*	3,500*	112	3,200*	3,200*	117	2,700*	2,700*	55
51	93	5,800*	3,500*	99	5,500*	3,300*	103	5,200*	3,100*	114	3,800*	2,700*	120	3,000*	2,500*	124	2,700*	2,200*	51
47	99	5,000*	2,800*	106	4,700*	2,500*	109	4,700*	2,500*	122	3,500*	2,100*	127	2,900*	1,900*	130	2,600*	1,800*	47
43	106	4,300*	2,100*	112	4,100*	2,000*	114	4,000*	1,900*	129	3,300*	1,500*	134	2,800*	1,400*	136	2,600*	1,300*	43
38	114	3,600*	1,500*	119	3,400*	1,400*	120	3,300*	1,300*	137	2,700*	1,000*	141	2,600*	900*	142	2,600*	900*	38
32	121	2,800*	900*	125	2,700*	700*	127	2,700*	700*	145	2,200*		148	2,100*		149	2,100*		32
25	128	2,200*		131	2,100*					152	1,700*		154	1,600*					25
17	134	1,800*		136	1,700*					159	1,300*		159	1,300*					17
0	140	500*								164	400*								0

Notes For Jib Capacities:
F. For all boom lengths less than the maximum with a jib erected, the rated loads are determined by boom angle only in the appropriate column.
G. For boom angles not shown, use the capacity of the next lower boom angle.
H. Listed radii are for fully extended main boom only.

ON TIRES WITH 11000 LB. COUNTERWEIGHT

MAX RADIUS (FT)	BOOM LENGTH (FT)	ALL		
		STATIONARY	PICK & CARRY	
			STRAIGHT OVER REAR	CREEP
10	35	23,500	23,500	16,100*
12	35	22,400	22,400	14,400*
15	35	20,700	20,700	12,200*
20	50	18,000	16,700	9,200*
25	50	15,200	13,600	6,900*
30	50	11,200	11,000	5,000*
35	50	8,900	8,900	3,700*
40	65	7,400	7,400	2,800*
45	65	6,000	6,000	2,100*
50	65	4,700	4,700	1,500*
55	65	3,800	3,800	
60	80	3,000	3,000	
65	80	2,300	2,300	
70	80	1,800	1,800	

Notes For On Tire Capacities:
A. For Pick and Carry Operations, boom must be centered over the rear of the machine.
B. The load should be restrained from swinging.
C. Creep Speed is crane movement of less than 200 ft. (61 m) in a 30 minute period and not exceeding 1.0 mph (1.6 km/h).
D. Refer to General Notes for additional information.
E. Without outriggers, never maneuver the boom beyond listed load radii for applicable tires used to ensure stability.

MAXIMUM PERMISSIBLE HOIST LINE LOAD

LINE PARTS	1	2	3	4	5	6	7	8	9	10	11	12
MAX. LOAD(18x19)	9,080	18,160	27,240	36,320	45,400	54,480	63,560	72,640	81,720	90,800	99,880	108,960
MAX. LOAD(6X19)	10,000	20,000	30,000	40,000	50,000	60,000	70,000	80,000	90,000	100,000	110,000	120,000
BOOM HEAD	2	3-D	2-3	1-4-D	2-3-4	2-3-4-D	1-2-3-4	1-2-3-4-D	1-2-3-4-5	1-2-3-4-5-D	1-2-3-4-5-6-D	1-2-3-4-5-6-D
HOOK BLOCK	D	3	3-D	1-4	2-3-D	2-3-4	2-3-4-D	1-2-3-4	1-2-3-4-D	1-2-3-4-5	1-2-3-4-5	1-2-3-4-5-6
WIRE ROPE: 5/8" ROTATION RESISTANT COMPACTED STRAND, 18X19 OR 19X19 MINIMUM BREAKING STRENGTH – 22.7 TONS 5/8" 6X9 OR 6X37 IWRC IPS PREFORMED RIGHT REGULAR LAY MINIMUM BREAKING STRENGTH – 17.9 TONS												

GENERAL NOTES

GENERAL

1. Rated loads as shown on Lift Charts pertain to this machine as originally manufactured and equipped. Modifications to the machine or use of optional equipment other than that specified can result in a reduction of capacity.
2. Construction equipment can be hazardous if improperly operated or maintained. Operation and maintenance of this machine shall be in compliance with the information in the Operator's, Parts and Safety Manuals supplied with this machine. If these manuals are missing, order replacements from the manufacturer through your distributor.
3. These warnings do not constitute all of the operating conditions for the crane. The operator and job site supervision must read the OPERATORS MANUAL, CIMA SAFETY MANUAL, APPLICABLE OSHA REGULATIONS, AND SOCIETY OF MECHANICAL ENGINEERS (ASME) SAFETY STANDARDS FOR CRANES.
4. This crane and its load ratings are in accordance with POWER CRANE & SHOVEL ASSOCIATION, STANDARD NO. 4, SAE CRANE LOAD STABILITY TEST CODE J765A, SAE METHOD OF TEST FOR CRANE STRUCTURE J1063 AND APPLICABLE SAFETY CODE FOR CRANES, DERRICKS AND HOISTS, ASME/ANSI B30.5.

DEFINITIONS

1. **LOAD RADIUS** – The horizontal distance from the axis of rotation before loading to the center of the vertical hoist line or tackle with a load applied.
2. **LOADED BOOM ANGLE** – It is the angle between the boom base section and the horizontal, after lifting the rated load at the rated radius. The boom angle before loading should be greater to account for deflections. The loaded boom angle combined with boom length give only an approximation of the operating radius.
3. **WORKING AREA** – Areas measured in a circular arc about the centerline of rotation as shown in the diagram.
4. **FREELY SUSPENDED LOAD** – Load hanging free with no direct external force applied except by the hoist rope.
5. **SIDE LOAD** – Horizontal force applied to the lifted load either on the ground or in the air.
6. **NO LOAD STABILITY LIMIT** – The stability limit radius shown on the range diagrams is the radius beyond which it is not permitted to position the boom, when the boom angle is less than the minimum shown on the applicable load chart, because the machine can overturn without any load.
7. **BOOM SIDE OF CRANE** – The side of the crane over which the boom is positioned when in an OVER SIDE working position.

SET-UP

1. Crane load ratings are based on the crane being leveled and standing on a firm, uniform supporting surface.
2. Crane load ratings on outriggers are based on all outrigger beams being fully extended or in the case of partial extension ratings mechanically pinned in the appropriate position, and the tires free of the supporting surface.
3. Crane load ratings on tires depend on appropriate inflation pressure and the tire conditions. Caution must be exercised when increasing air pressures in tires. Consult Operator's Manual for precautions.
4. Use of jibs, lattice-type boom extensions, or fourth section pullouts extended is not permitted for pick and carry operations.
5. Consult appropriate section of the Operator's and Service Manual for more exact description of hoist line reeving.
6. The use of more parts of line than required by the load may result in having insufficient rope to allow the hook block to reach the ground.
7. Properly maintained wire rope is essential for safe crane operation. Consult Operator's Manual for proper maintenance and inspection requirements.

8. When spin-resistant wire rope is used, the allowable rope loading shall be the breaking strength divided by five (5), unless otherwise specified by the wire rope manufacturer.

OPERATION

1. **CRANE LOAD RATINGS MUST NOT BE EXCEEDED. DO NOT ATTEMPT TO TIP THE CRANE TO DETERMINE ALLOWABLE LOADS.**
2. When either radius or boom length, or both, are between listed values, the smaller of the two listed load ratings shall be used.
3. Do not operate at longer radii than those listed on the applicable load rating chart (cross hatched areas shown on range diagrams).
4. The boom angles shown on the Capacity Chart give an approximation of the operating radius for a specified boom length. The boom angle, before loading, should be greater to account for boom deflection. It may be necessary to retract the boom if maximum boom angle is insufficient to maintain rated radius.
5. Power telescoping boom sections must be extended equally.
6. Rated loads include the weight of hook block, slings, and auxiliary lifting devices. Their weights shall be subtracted from the listed rated load to obtain the net load that can be lifted.
When lifting over the jib the weight of any hook block, slings, and auxiliary lifting devices at the boom head must be added to the load.
When jibs are erected but unused add two (2) times the weight of any hook block, slings, and auxiliary lifting devices at the jib head to the load.
7. Rated loads do not exceed 85% on outriggers or 75% on tires, of the tipping load as determined by SAE Crane Stability Test Code J765a. Structural strength ratings in chart are indicated with an asterisk (*).
8. Rated loads are based on freely suspended loads. No attempt shall be made to drag a load horizontally on the ground in any direction.
9. The user shall operate at reduced ratings to allow for adverse job conditions, such as: Soft or uneven ground, out of level conditions, high winds, side loads, pendulum action, jerking or sudden stopping of loads, hazardous conditions, experience of personnel, two machine lifts, traveling with loads, electric wires, etc., (side pull on boom or jib is hazardous). Derating of the cranes lifting capacity is required when wind speed exceeds 20 MPH. The center of the lifted load must never be allowed to move more than 3" feet off the center line of the base boom section due to the effects of wind, inertia, or any combination of the two.
**Use 2 feet off the center line of the base boom for a two section boom, 3 feet for a three section boom, or 4 feet for a four section boom.
10. The maximum load which can be telescoped is not definable, because of variations in loadings and crane maintenance, but it is permissible to attempt retraction and extension if load ratings are not exceeded.
11. Load ratings are dependent upon the crane being maintained according to manufacturer's specifications.
12. It is recommended that load handling devices, including hooks, and hook blocks, be kept away from boom head at all times.
13. **FOR TRUCK ONLY:** 360° capacities apply only to machines equipped with a front outrigger jack and all five (5) outrigger jacks properly set. If the front (5th) outrigger jack is not properly set, the work area is restricted to the over side and over rear areas as shown on the Crane Working Positions diagram. Use the 360° load ratings in the overside work areas.
14. Do not lift with outrigger beams positioned between the fully extended and intermediate (pinned) positions.

BASIC DIMENSIONS

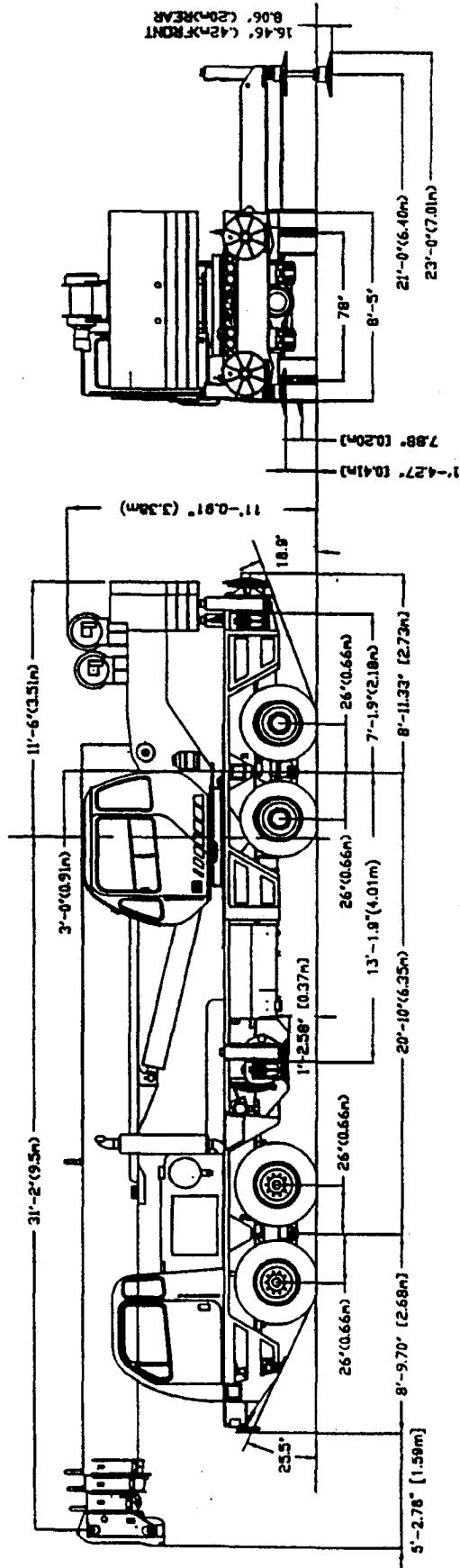

	'A'	'B'
FULLY EXTENDED OUTRIGGERS	21'-0"	23'-0"
PINNED OUTRIGGERS	14'-4.5"	16'-4.5"
FULLY RETRACTED OUTRIGGERS	7'-8.5"	9'-8.5"

NOTE: DUMPING THE AIR SUSPENSION
LOWERS THE CRANE 2".