



# MODEL 2120SCT/4240SCT

## 120 ton / 240 ton Gantry System

### CAPACITY:

#### 4 Point - MODEL 4240SCT

244 (221) Tons to 15'6" (4724 mm)  
154 (139) Tons to 21'3" (6477 mm)  
100 (90) Tons to 27'0" (8230 mm)

#### 2 Point - MODEL 2120SCT

122 (110) Tons to 15'6" (4724 mm)  
77 (69) Tons to 21'3" (6477 mm)  
50 (45) Tons to 27'0" (8230 mm)

Max. Operating PSI: 2150 (148 bar)

### BASE DIMENSIONS:

Length: 66-1/4" (1683 mm)  
Width: 36" (914 mm)  
Height Retracted: 9'9" (2972 mm)  
Weight: 5500 lbs. (2497 kg)

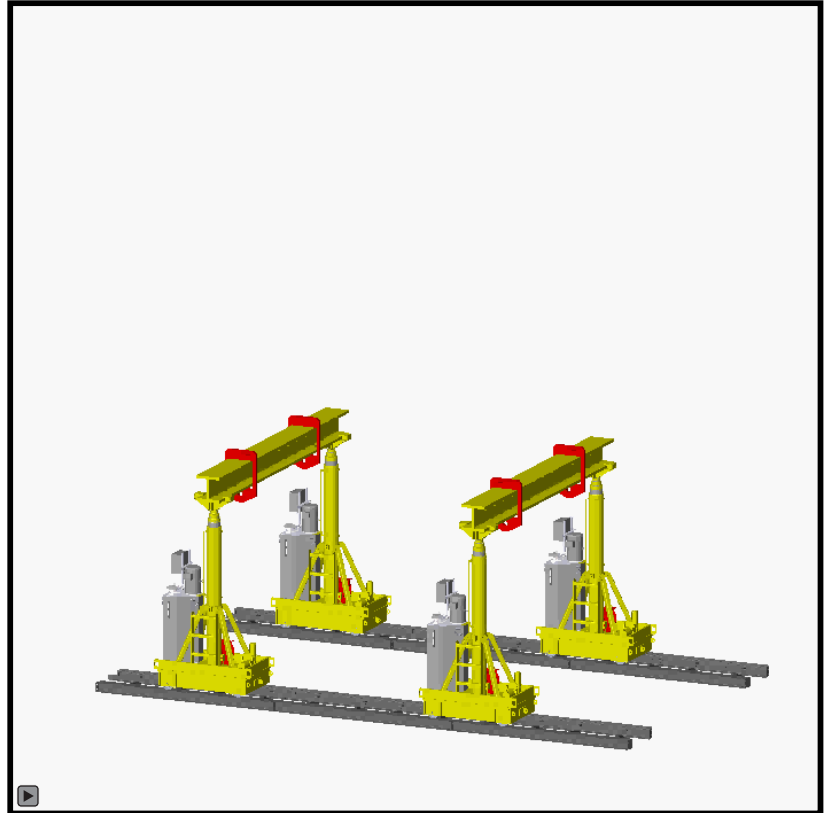

## STANDARD FEATURES

- Double Acting Cylinders
- Safety Holding Valves
- Self Contained Hydraulics
- Pendant Control
- 220 volt / 60 Hz / 30 amp draw
- 65 Gallon (246 L) Reservoir
- 4.5 g.p.m. Pump

### LIFT SYSTEMS, INC.

OFFICE:  
1505 - 7th Street  
East Moline, IL 61244

MAILING ADDRESS:  
P.O. Box 906  
Moline, IL 61266

TEL: +1-309-764-9842  
FAX: +1-309-764-9848  
EMAIL: [liftit@lift-systems.com](mailto:liftit@lift-systems.com)  
WEB: [www.lift-systems.com](http://www.lift-systems.com)

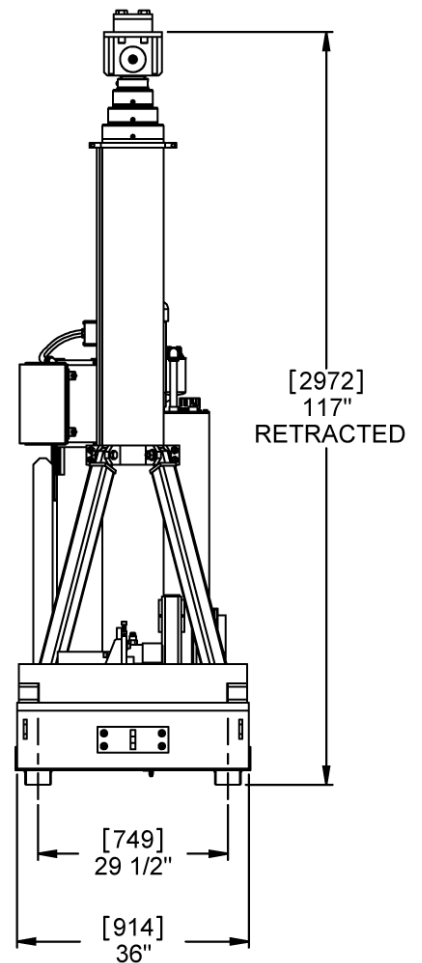
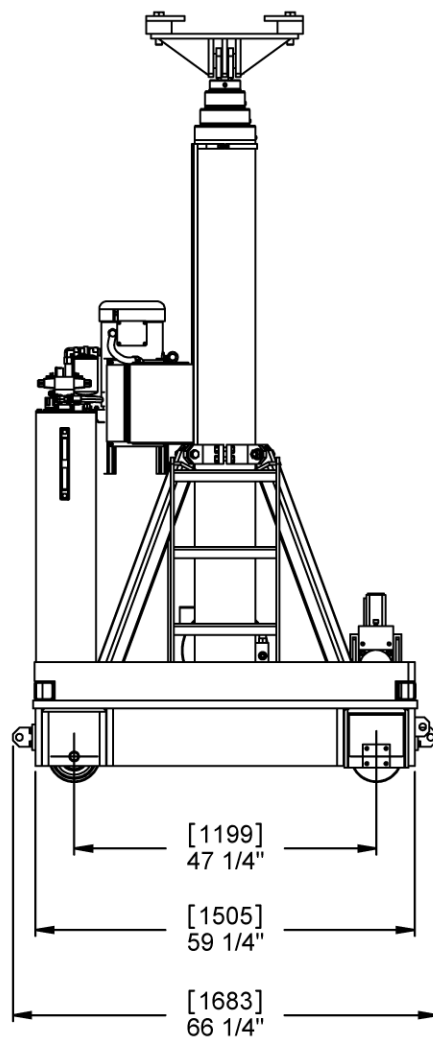
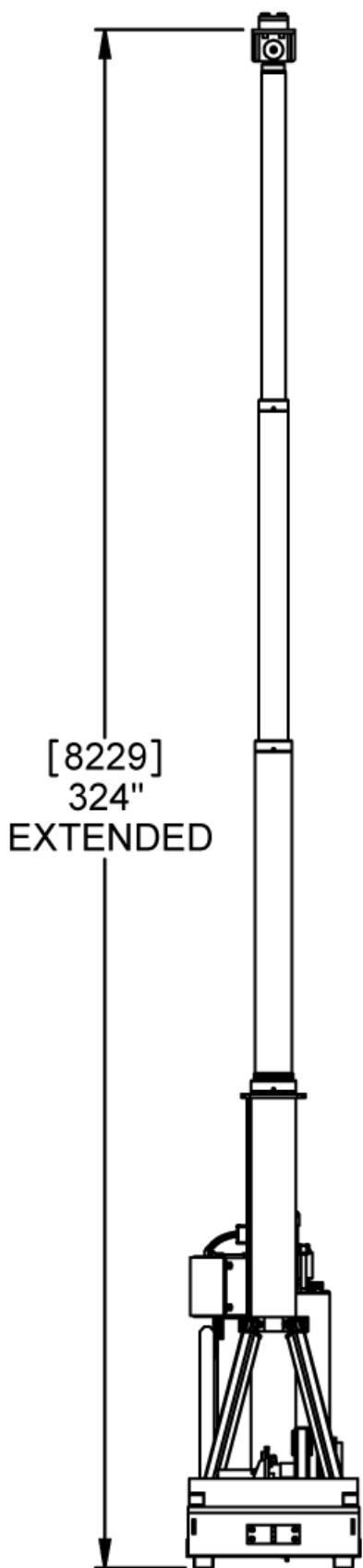

Metric dimensions [mm]

## MODEL 2120SCT / 4240SCT

### OPTIONAL EQUIPMENT AND FEATURES

- Powered Drives
- Lifting Links
- Runway Track
- Lifting Beams with Certified Load Charts
- Side Shift Systems
- CARL Computerized Synchronization System
- Radio Remote Control
- Training Technicians

#### LIFT SYSTEMS, INC.

OFFICE:  
1505 - 7th Street  
East Moline, IL 61244

MAILING ADDRESS:  
P.O. Box 906  
Moline, IL 61266

TEL: +1-309-764-9842  
FAX: +1-309-764-9848  
EMAIL: [liftit@lift-systems.com](mailto:liftit@lift-systems.com)  
WEB: [www.lift-systems.com](http://www.lift-systems.com)