

National Crane Series NBT36

Product Guide



Features

- 32,7 t (36 USt) rating
- 38,7 m (127 ft) five-section boom
- Self-lubricating Easy Glide wear pads



Features

National Crane Series NBT36

- 32,7 t (36 USt) maximum capacity
- 41,1 m (135 ft) maximum tip height (main boom)
- 57,9 m (190 ft) maximum tip height (boom with jib)

Five-section boom

At 38,7m (127 ft), the NBT36 five-section boom is the longest in its size range. The long boom allows the operator to perform more lifts without the use of a jib, reducing setup time and improving efficiency. Also available is optional boom length of 31,4 m (103 ft).

Overload protection

All National Crane boom trucks are equipped with overload protection. A Load Moment Indicator (LMI) is standard on all NBT36 machines. The LCD display is visible in full or low light and displays all crane load lifting values simultaneously. Includes Work Area Definition System (WADS).



Deluxe operator's cab

Rigid galvanealed steel structure, well insulated, with tinted safety glass for operator visibility and comfort. Multi-position seat with arm rest mounted single axis controls, ventilation fans, diesel heater, dual cab mounted worklights and wipers. Optional air conditioning is available.



Outriggers

Outrigger span of 7,52 m (24.7 ft) when fully extended; 5,33 m (17.5 ft) at mid-span.

Equipped with both ground level and in-cab outrigger controls, the NBT36 outriggers allow quick and easy crane set-up and can be positioned at 0%, 50% and 100%.



National Crane is proud to introduce the Series NBT36

- The stronger standard torsion box improves rigidity, reduces truck frame flex and reduces the need for counterweight.
- Easy Glide boom wear pads reduce the conditions that cause boom chatter and vibration. The net result is smoother crane operation.
- Speedy-reeve boom tip and sheave blocks simplify rigging changes by decreasing the time needed to change line reeving.
- Painting crane components before assembly reduces the possibility of rust, improves serviceability and enhances the appearance of the machine.
- State of the art control valve provides smoother operation. The new design eliminates parts, reducing repair costs and improving the machines serviceability.
- Bearings on the boom and retract cables can be greased through access holes in the boom side plates.
- Boom sections are supported by one hydraulic extend cylinder, minimizing maintenance.
- Two-speed grooved drum hoist with cable packer, electronic drum rotation indicator (DRI), last layer indicator (LLI), and third wrap indicator.

Contents

Specifications	5
Mounting configuration	7
Dimensions	8
Working range - 103 ft boom	9
Load charts - 103 ft boom	10
Working range - 127 ft boom	14
Load charts - 127 ft boom	15
Accessories	17

Specifications

Boom and jib combinations data

Available in two basic models:

NBT36 - 103: Equipped with a 9,45 m - 31,39 m (31 ft - 103 ft) four-section boom. This model can be equipped with a 9,45 m (31 ft) jib, offering a tip height of 43,29 m (142 ft) or a 9,45 m - 16,76 m (31 ft- 55 ft) side-stowing foldaway jib, providing a tip height of 50,60 m (166 ft).

9,45 m - 31,39 m (31 ft - 103 ft) four-section hydraulic boom **18FJ31OS** 9,45 m (31 ft) single-section offsettable manual jib



9,45 m - 31,39 m (31 ft - 103 ft) four-section hydraulic boom **18FJ55M** 9,45 m - 16,76 m (31 ft - 55 ft) two-section manual jib



NBT36-127: Equipped with a 9,45 m - 38,71 m (31 ft - 127 ft) five-section boom. This model can be equipped with a 9,45 m - 16,76 m (31 ft - 55 ft) fold-away jib providing a tip height of 57,91 m (190 ft).

9,45 m - 38,71 m (31 ft - 127 ft) five-section hydraulic boom **18FJ55M** 9,45 m - 16,76 m (31 ft - 55 ft) two-section manual jib



Note: Maximum tip is measured with outriggers/stabilizers fully extended.

Specifications

NBT36 winch data

- All winch pulls and speeds are shown on the fourth layer.
- Winch line pulls would increase on the first, second, and third layers.
- Winch line speed would decrease on the first, second, and third layers.
- Winch line pulls may be limited by the winch capacity or the ANSI 5 to 1 cable safety factor.

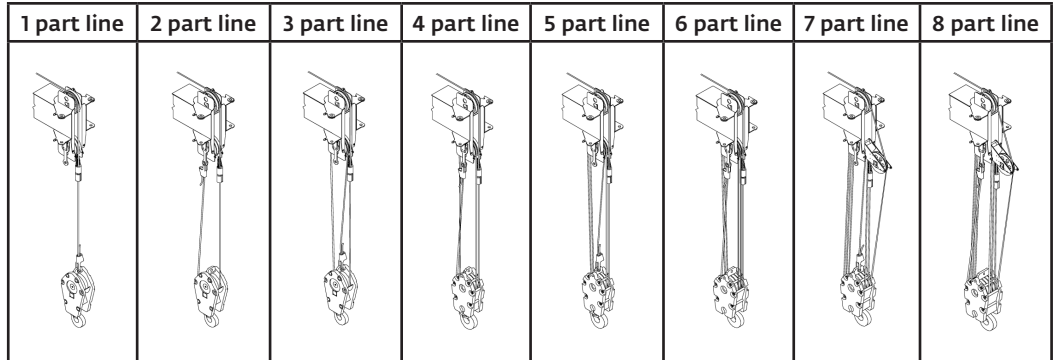

Standard planetary winch	Cable supplied	Average breaking strength	Max. pull	Max. pull	Max. pull	Max. pull	Max. pull	Max. pull	Max. pull	Max. pull
Low speed	5/8" diameter rotation resistant IWRC	25 583 kg (56,400 lb)	5103 kg (11,250 lb) 62 m/min (205 fpm)	10 206 kg (22,500 lb) 31 m/min (103 fpm)	15 309 kg (33,750 lb) 21 m/min (68 fpm)	20 412 kg (45,000 lb) 16 m/min (51 fpm)	25 515 kg (56,250 lb) 13 m/min (41 fpm)	30 618 kg (67,500 lb) 10 m/min (34 fpm)	35 721 kg (78,750 lb) 9 m/min (29 fpm)	40 824 kg (90,000 lb) 8 m/min (26 fpm)
High speed	5/8" diameter rotation resistant IWRC	25 583 kg (56,400 lb)	2268 kg (5000 lb) 125 m/min (410 fpm)	4536 kg (10,000 lb) 62 m/min (205 fpm)	6804 kg (15,000 lb) 42 m/min (137 fpm)	9072 kg (20,000 lb) 31 m/min (103 fpm)	11 340 kg (25,000 lb) 25 m/min (82 fpm)	13 608 kg (30,000 lb) 21 m/min (68 fpm)	15 876 kg (35,000 lb) 18 m/min (59 fpm)	18 144 kg (40,000 lb) 16 m/min (51 fpm)

Winch	Fourth layer pull	Allowable cable pull
Standard planetary and auxiliary planetary	2268 kg (5000 lb) high speed 5103 kg (11,250 lb) low speed	5117 kg (11,280 lb) 5117 kg (11,280 lb)

Block type	Rating	Weight
Aux boom head		45 kg (100 lb)
Downhaul weight	4,53 USt (7 USt)	78 kg (172 lb)
1-sheave block	13,60 t (20 USt)	149 kg (329 lb)
2-sheave block	22,67 t (30 USt)	290 kg (640 lb)
3-sheave block	31,74 t (40 USt)	272 kg (600 lb)
4-sheave block	32,65 t (50 USt)	361 kg (796 lb)

Mounting configuration

The configurations are based on the NBT36 with an 85% stability factor. The complete unit must be installed in accordance with factory requirements and a test performed to determine actual stability and counterweight requirements since individual truck chassis vary.

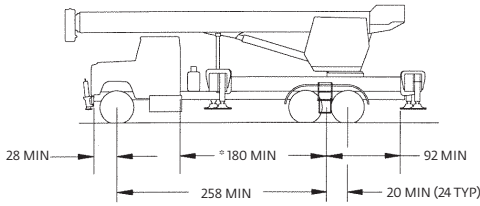

*CLEAR OF OBSTRUCTIONS (MUFFLERS, EXHAUST STACKS, ETC.) ON TOP OF TRUCK FRAME FOR FULL 8 FOOT WIDTH.

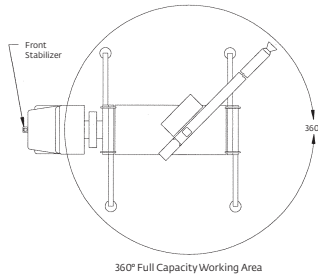

360° Full Capacity Working Area

The diagram shows the 360° working area achieved with the front stabilizer (standard on the Series NBT36). The front stabilizer is required when extending the boom and lifting loads over the front of the truck. A minimum of 104 cm³ (10 in³) section modulus at 758 MPa (110,000 psi) is required from the rear of the front spring hanger forward to the front stabilizer. Integral front frame extension required.

*Required to mount basic crane with 9,45 m (30 ft) jib option. Additional options or heavier base chassis weights will require additional axles or a GVWR in excess of 24 494 kg (54,000 lb); in some states, special permits for overload are required.

••Estimated axle scale weights prior to installation of crane, stabilizers and subbase for 85% stability.

***Includes basic crane without jib, 379 L (100 gal) fuel tank and two workers in cab. **Note: Chassis will require extended front frame rails for SFO addition.**

Configuration 1 – NBT 36

Working area	360°
Gross Axle Weight Rating Front	9072 kg (20,000 lb)*
Gross Axle Weight Rating Rear	15 422 kg (34,000 lb)*
Gross Vehicle Weight Rating	24 494 kg (54,000 lb)*
Wheelbase	655 cm (258 in)
Cab to Axle/trunnion (CA/CT)	457 cm (180 in)
After Frame (AF)	2,44 m (92 in) minimum
Frame Section Modulus (SM), front axle to end of afterframe, with 758 MPa (110,000 PSI)	492 cm ³ (30 in ³)
Stability Weight, Front	4410 kg (9700 lb) minimum**
Stability Weight, Rear	3865 kg (8500 lb) minimum**
Estimated Average Final Weight	23 587 kg (51,880 lb)***

MINIMUM TRUCK REQUIREMENTS

Many factors must be considered in the selection of proper truck for a Series NBT36 crane. Items which must be considered are:

- 1. Axle Rating.** Axle ratings are determined by the axles, tires, rims, springs, brakes, steering and frame strength of the truck. If any one of these components is below the required rating, the gross axle rating is reduced to its weakest component value.
- 2. Wheelbase (WB), Cab-to-Trunnion (CT) and Bare Chassis Weight.** The wheelbase, CT and chassis weights shown are required so the basic NBT36 can be legally driven in most states and meet stability requirements. The dimensions given assume the sub-base is installed properly behind the truck cab. If exhaust stacks, transmission protrusions, etc., do not allow a close installation to the cab, the WB and CT dimensions must be increased. Refer to the Mounting Configuration pages for additional information.
- 3. Truck Frame.** Try to select a truck frame that will minimize or eliminate frame reinforcement or extension of the after frame (AF). Many frames are available that have the necessary after frame (AF) section modulus (S.M.) and resistance to bending moment (RBM)

so that reinforcing is not required. The front hydraulic jack is used for a 360° working range around the truck. The frame under the cab through the front suspension must have the minimum S.M. and RBM because reinforcing through the front suspension is often difficult because of engine, radiator mounts and steering mechanics. See "Truck Requirements" and "Frame Strength" information above for the necessary section modulus and resistance to bending moment values.

- 4. Additional Equipment.** In addition to the axle ratings, wheelbase, cab-to-axle requirements and frame, it is recommended that the truck is equipped with electronic engine control, increased cooling and a transmission with a PTO opening available with an extra heavy duty PTO. A conventional cab truck should be used for standard crane mounts.
- 5. Neutral Start Switch.** The chassis must be equipped with a switch that prevents operation of the engine starter when the transmission is in gear.

Notes:

- Gross Vehicle Weight Rating (GVWR) is dependent on all components of the vehicle (axles, tires, springs, frame, etc.) meeting manufacturers' recommendations; always specify GVWR when purchasing trucks.
- Diesel engines require a variable speed governor for smooth crane operation; electronic fuel injection requires EET engine remote throttle.
- All mounting data is based on a National Crane Series NBT36 with an 85% stability factor (75% stability factor for New York City).
- The complete unit must be installed in accordance with factory requirements, and a test performed to determine actual stability and counterweight requirements per SAE J765; contact the factory for details.

Dimensions

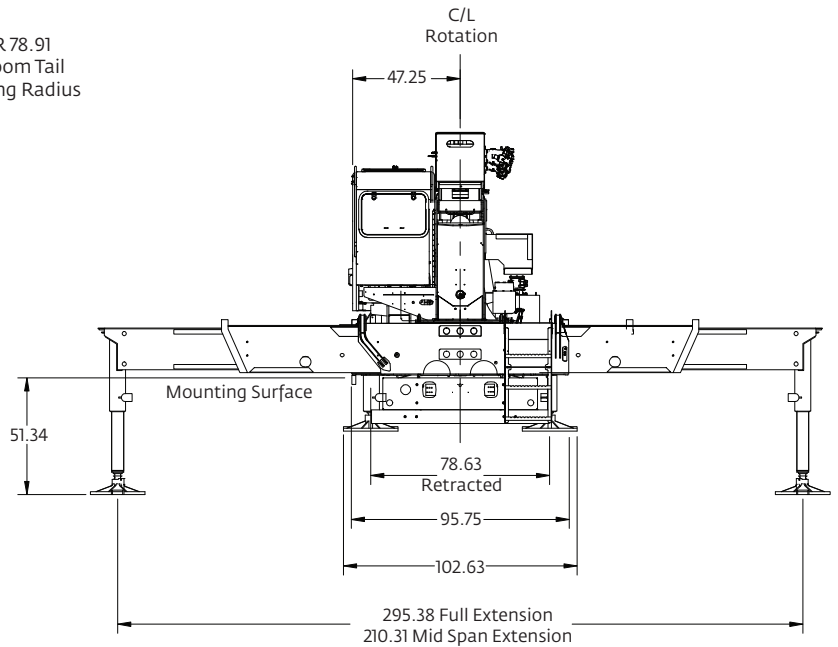
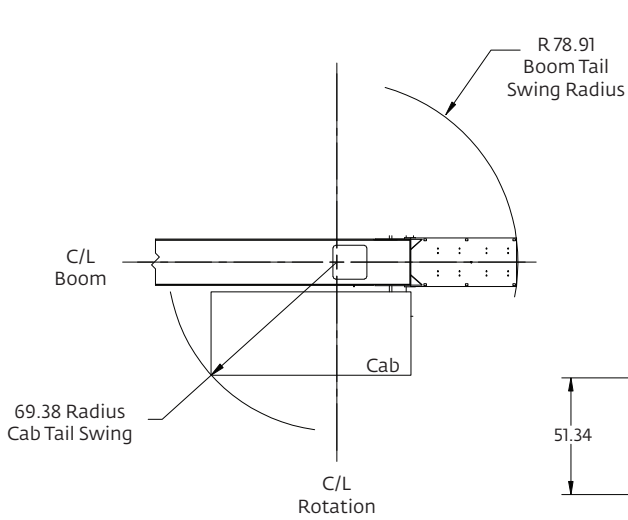
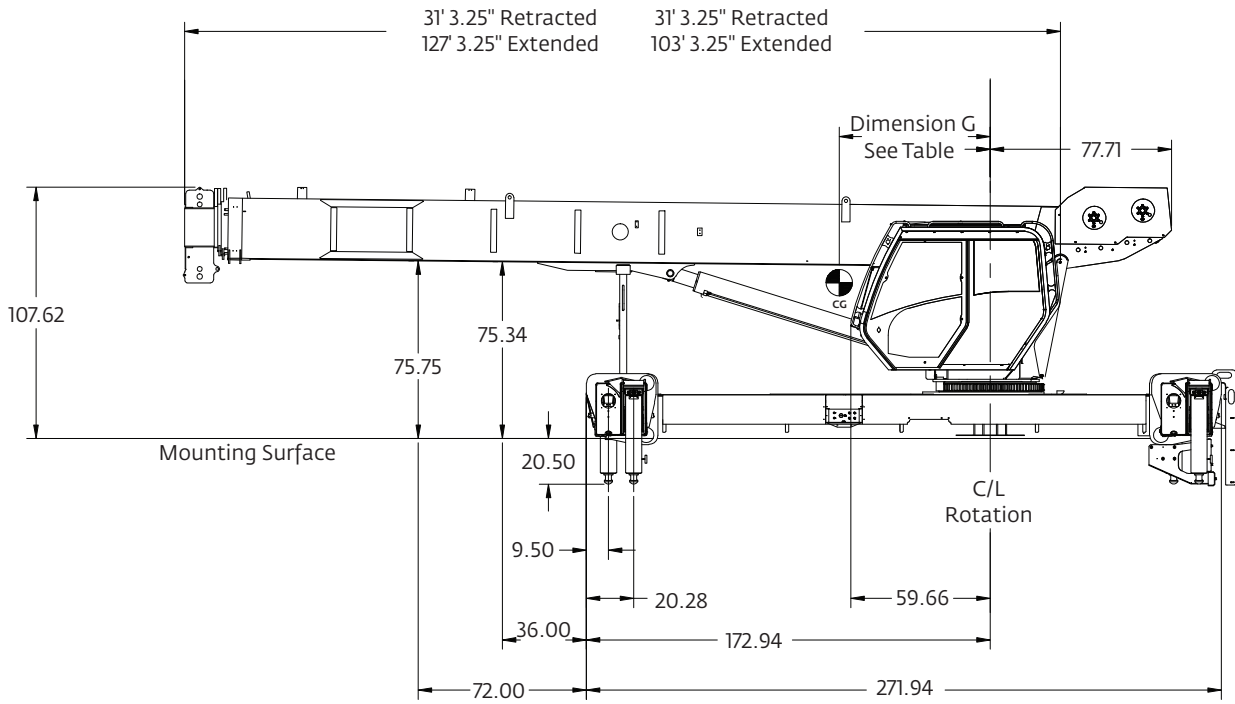

Dimensions are in inches unless otherwise specified.

Series	G	Weight with oil
NBT36103	75.5"	34,084 lb
NBT36127	79"	35,394 lb

No jib, no auxiliary hoist, with 2/3 hookblock.

Working range

103 ft main boom, full span outrigger, with jib

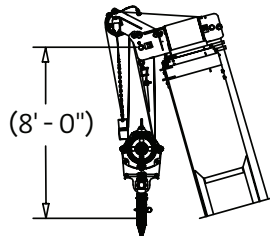
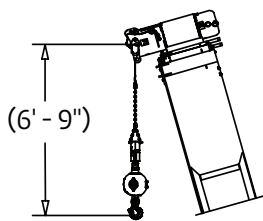
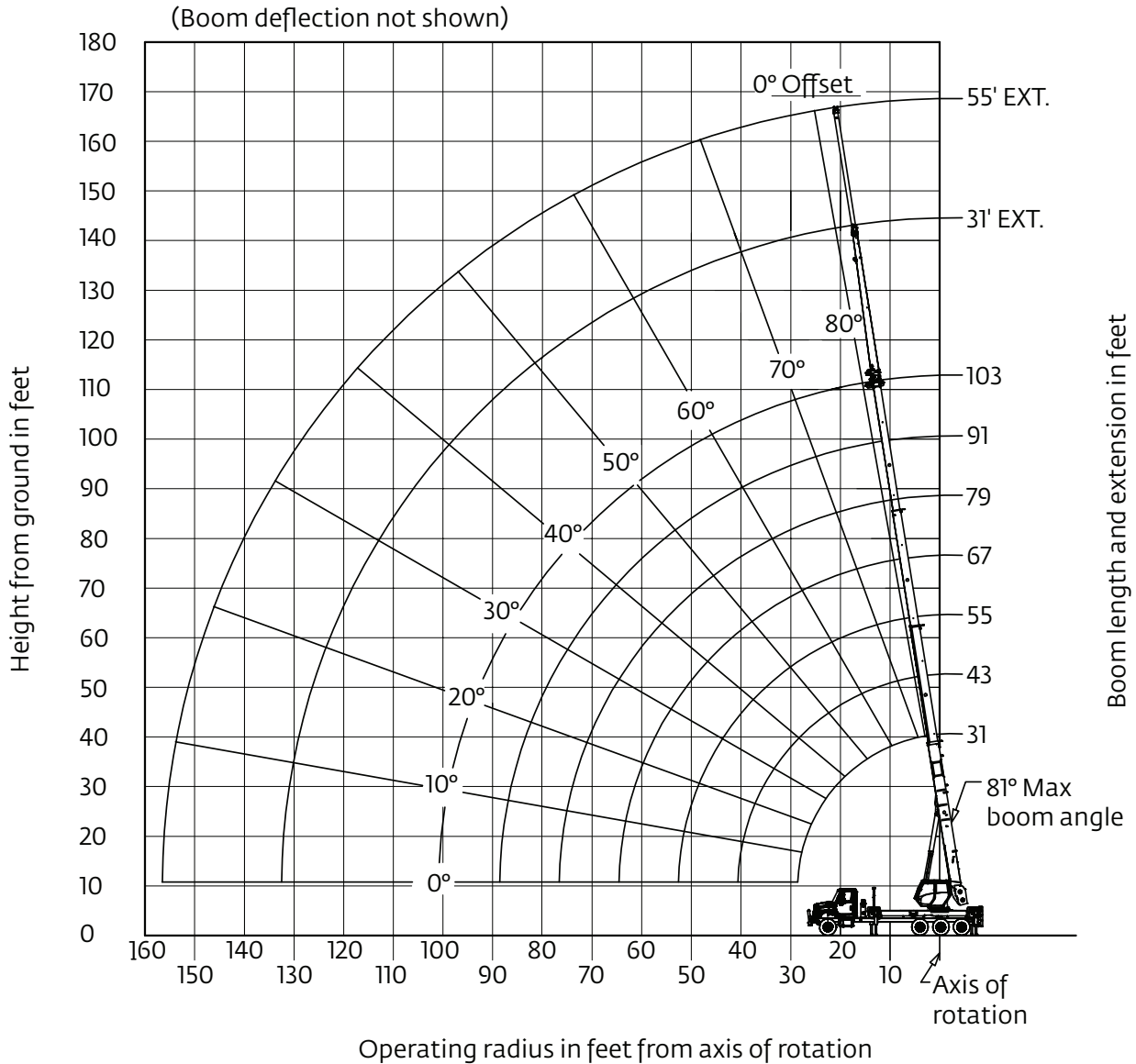

Dimensions are for largest furnished hook block and headache ball, with anti-two block activated.

*Drawing is to show the physical reach of the machine. Always refer to load chart to see what portions of this range are structurally and stability limited.

Load chart

103 ft main boom, full span outrigger, 360°, without stowed jib

Radius in feet	#01						
	Main boom length in feet						
	31	43-A	55-B	67-C	79-D	91-E	103
7	72,000 (73.9)						
8	69,000 (72)	50,000 (76.9)					
10	66,500 (68)	48,000 (74.1)	49,000 (78)				
12	55,000 (63.9)	46,000 (71.2)	46,000 (75.8)	36,000 (78.7)			
15	43,400 (57.5)	43,500 (66.8)	39,000 (72.5)	35,000 (76.1)	31,000 (78.7)		
20	31,300 (45.5)	31,600 (59.1)	31,900 (66.8)	32,000 (71.6)	26,000 (75.1)	18,000 (77.3)	18,000 (79.4)
25	23,900 (29.9)	24,200 (50.6)	24,500 (60.8)	24,700 (66.9)	24,800 (71.2)	17,500 (74.2)	17,000 (76.8)
30		18,100 (40.9)	18,350 (54.4)	18,500 (62)	18,650 (67.1)	17,000 (71)	16,000 (74)
35		13,900 (28.6)	14,150 (47.4)	14,300 (56.8)	14,450 (62.9)	14,550 (67.5)	14,500 (71.1)
40			11,250 (39.5)	11,400 (51.3)	11,500 (58.6)	11,600 (63.9)	11,700 (67.9)
45			9200 (31)	9350 (45.9)	9450 (54.5)	9550 (60.5)	9650 (65)
50			7500 (17.4)	7650 (39.4)	7800 (49.7)	7580 (56.6)	7950 (61.7)
55				6350 (31.7)	6450 (44.5)	6550 (52.5)	6600 (58.3)
60				5250 (21.6)	5350 (38.8)	5450 (48.2)	5500 (54.7)
65					4500 (32.3)	4550 (43.6)	4600 (51)
70					3700 (24.2)	3750 (38.6)	3850 (47.1)
75					2950 (11.1)	3050 (32.9)	3150 (43)
80						2450 (26)	2550 (38.4)
85						1950 (16.6)	2000 (33.4)
90							1550 (27.5)
95							1150 (19.9)
100							800 (4.6)
Minimum boom angle (°) for indicated length (no load)							0
Maximum boom length (ft) at 0° boom angle (no load)							103

NOTE: Loads displayed in pounds. () Boom angles are in degrees.
#LMI operating code. Refer to LMI manual for operating instructions.

Lifting capacities at zero degree boom angle							
Boom angle	Main boom length in feet						
	31	43-A	55-B	67-C	79-D	91-E	103
0°	18,800 (28.5)	11,150 (40.5)	6800 (52.5)	4450 (64.5)	2800 (76.5)	1650 (88.5)	800 (100.5)

NOTE: () Reference radii in feet. 80028768

Rated Load Reductions from main boom capacity when lifting over main boom nose with :							
tele. erected (retracted)	2300	2150	2000	1950	1900	1850	1800
31' off. erected at 0° offset	1800	1700	1550	1500	1450	1450	1400

Load chart

103 ft main boom, full span outrigger, 360°, with stowed jib

Radius in feet	#02						
	Main boom length in feet						
	31	43-A	55-B	67-C	79-D	91-E	103
7	71,200 (73.9)						
8	68,200 (72)	49,350 (76.9)					
10	65,700 (68)	47,350 (74.1)	48,550 (78)				
12	54,200 (63.9)	45,350 (71.2)	45,550 (75.8)	35,600 (78.7)			
15	42,600 (57.5)	42,850 (66.8)	38,550 (72.5)	34,600 (76.1)	30,650 (78.7)		
20	30,500 (45.5)	30,950 (59.1)	31,450 (66.8)	31,600 (71.6)	25,650 (75.1)	17,700 (77.3)	17,750 (79.4)
25	23,100 (29.9)	23,550 (50.6)	24,050 (60.8)	24,300 (66.9)	24,450 (71.2)	17,200 (74.2)	16,750 (76.8)
30		17,450 (40.9)	17,900 (54.4)	18,100 (62)	18,300 (67.1)	16,700 (71)	15,750 (74)
35		13,250 (28.6)	13,700 (47.4)	13,900 (56.8)	14,100 (62.9)	14,250 (67.5)	14,250 (71.1)
40			10,800 (39.5)	11,000 (51.3)	11,150 (58.6)	11,300 (63.9)	11,450 (67.9)
45			8750 (31)	8950 (45.9)	9100 (54.5)	9250 (60.5)	9400 (65)
50			7050 (17.4)	7250 (39.4)	7450 (49.7)	7280 (56.6)	7700 (61.7)
55				5950 (31.7)	6100 (44.5)	6250 (52.5)	6350 (58.3)
60				4850 (21.6)	5000 (38.8)	5150 (48.2)	5250 (54.7)
65					4150 (32.3)	4250 (43.6)	4350 (51)
70					3350 (24.2)	3450 (38.6)	3600 (47.1)
75					2600 (11.1)	2750 (32.9)	2900 (43)
80						2150 (26)	2300 (38.4)
85						1650 (16.6)	1750 (33.4)
90							1300 (27.5)
95							900 (19.9)
100							550 (4.6)
Minimum boom angle (°) for indicated length (no load)							0
Maximum boom length (ft) at 0° boom angle (no load)							103

NOTE: Loads displayed in pounds. () Boom angles are in degrees.
#LMI operating code. Refer to LMI manual for operating instructions.

Lifting capacities at zero degree boom angle							
Boom angle	Main boom length in feet						
	31	43-A	55-B	67-C	79-D	91-E	103
0°	18,000 (28.5)	10,500 (40.5)	6350 (52.5)	4050 (64.5)	2450 (76.5)	1350 (88.5)	550 (100.5)

NOTE: () Reference radii in feet.

80028771

Load chart

103 ft main boom, full span outrigger, 360°, with fixed jib

Radius in feet	0° OFFSET
	#06
24	8500 (80)
37	7500 (75)
48	6400 (70)
59	5100 (65)
69	3900 (60)
78	3000 (55)
87	2200 (50)
95	1500 (45)
102	1000 (40)
Min. boom angle for indicated length (no load)	25.4°
Max. boom length at 0° boom angle (no load)	91 ft

Radius in feet	30° OFFSET
	#09
39	6200 (80)
50	5400 (75)
60	4800 (70)
70	3900 (65)
79	3200 (60)
87	2400 (55)
95	1800 (50)
102	1300 (45)
107	900 (40)
Min. boom angle for indicated length (no load)	35°
Max. boom length at 0° boom angle (no load)	79 ft

80028774

NOTE: Loads displayed in pounds.
() Boom angles are in degrees.
#LMI operating code. Refer to LMI manual for
operating instructions.

Boom extension capacity notes:

- All capacities above the bold line are based on structural strength of boom extension.
- 31 ft offsettable extension length may be used for single line lifting service.
- Radii listed are for a fully extended boom with the boom extension erected. For main boom lengths less than fully extended, the rated loads are determined by boom angle. For boom angles not shown, use the rating of the next lower angle.
Warning: Operation of this machine with heavier loads than the capacities listed is strictly prohibited. Machine tipping with boom extension occurs rapidly and without advance warning.
- Boom angle is the angle above or below horizontal of the longitudinal axis of the boom base section after lifting rated load.
- Capacities listed are with outriggers properly extended and vertical jacks set.
- When lifting over the main boom nose with 31 ft offsettable extension erected, the outriggers must be fully extended or 50% (17.5 ft) spread.

Load chart

103 ft main boom, full span outrigger, 360°, with telescopic jib

Radius in feet	31 ft LENGTH
	#03
24	8500 (80)
37	7500 (75)
48	6400 (70)
59	5100 (65)
69	3900 (60)
78	2800 (55)
87	1900 (50)
95	1250 (45)
102	750 (40)
Min. boom angle for indicated length (no load)	37.8°
Max. boom length at 0° boom angle (no load)	79 ft

Boom extension capacity notes:

1. All capacities above the bold line are based on structural strength of boom extension.
2. 31 ft and 55 ft extension lengths may be used for single line lifting service.
3. Radii listed are for a fully extended boom with the boom extension erected. For main boom lengths less than fully extended, the rated loads are determined by boom angle. For boom angles not shown, use the rating of the next lower angle. **Warning:** Operation of this machine with heavier loads than the capacities listed is strictly prohibited. Machine tipping with boom extension occurs rapidly and without advance warning.
4. Boom angle is the angle above or below horizontal of the longitudinal axis of the boom base section after lifting rated load.
5. Capacities listed are with outriggers properly extended and vertical jacks set.
6. when lifting over the main boom nose with 31 ft or 55 ft extension erected, the outriggers must be fully extended or 50% (17.5 ft) spread.

Radius in feet	55 ft LENGTH
	#04
29	4000 (80)
45	3700 (75)
59	3200 (70)
71	2700 (65)
83	2250 (60)
94	1800 (55)
104	1300 (50)
113	800 (45)
Min. boom angle for indicated length (no load)	41.5°
Max. boom length at 0° boom angle (no load)	79 ft

80028776

NOTE: Loads displayed in pounds.

() Boom angles are in degrees.

#LMI operating code. Refer to LMI manual for operating instructions.

THIS CHART IS ONLY A GUIDE AND SHOULD NOT BE USED TO OPERATE THE CRANE.

Working range

127 ft main boom, full span outrigger, with jib

(Boom deflection not shown)

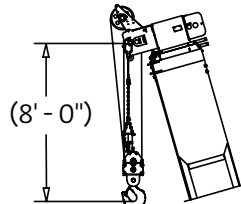
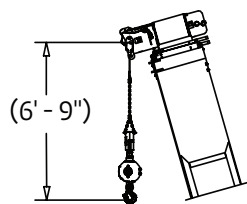
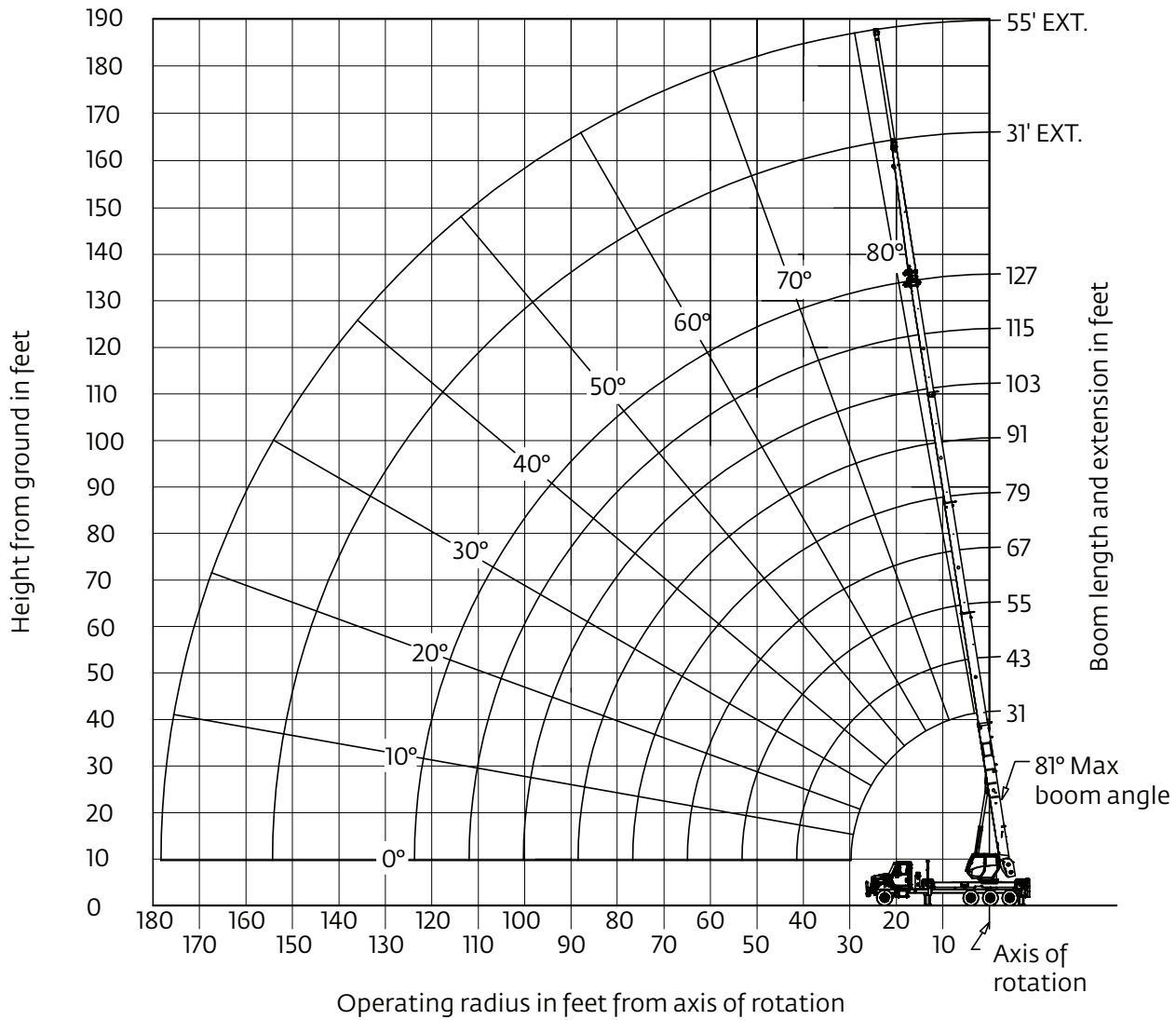

Dimensions are for largest furnished hook block and headache ball, with anti-two block activated.

*Drawing is to show the physical reach of the machine. Always refer to load chart to see what portions of this range are structurally and stability limited.

THIS CHART IS ONLY A GUIDE AND SHOULD NOT BE USED TO OPERATE THE CRANE.

The individual crane's load chart, operating instructions and other instructional plates must be read and understood prior to operating the crane.

Load chart

127 ft main boom, full span outrigger, 360°, without stowed jib

Radius in feet	#01								
	Main boom length in feet								
	31	43-A	55-B	67-C	79-D	91-E	103-F	115-G	127
7	72,000 (73.6)								
8	70,000 (71.6)								
10	66,000 (67.6)	40,000 (74.2)							
12	54,600 (63.4)	38,000 (71.4)	39,000 (75.8)	36,000 (78.8)					
15	42,700 (56.8)	36,000 (67)	37,000 (72.6)	34,000 (76.2)	27,000 (78.6)	21,000 (80.4)			
20	30,800 (44.4)	31,300 (59.4)	31,800 (66.9)	32,000 (71.7)	24,000 (74.9)	19,000 (77.2)	15,500 (79.2)	12,500 (80.7)	
25	23,400 (27.8)	24,000 (51)	24,400 (61)	24,600 (67)	20,500 (71.1)	16,000 (74)	14,200 (76.5)	12,000 (78.4)	9500 (79.9)
30		18,050 (41.4)	18,450 (54.6)	18,700 (62.1)	18,500 (67.2)	15,200 (70.8)	13,000 (73.7)	11,800 (76)	9100 (77.9)
35		13,800 (29.4)	14,200 (47.7)	14,450 (57)	14,650 (63)	14,000 (67.4)	12,100 (70.8)	11,100 (73.7)	8700 (75.8)
40			11,250 (39.9)	11,500 (51.5)	11,650 (58.7)	11,800 (63.9)	11,200 (67.9)	10,100 (71.2)	8500 (73.6)
45			9150 (31.5)	9400 (46.2)	9550 (54.6)	9700 (60.4)	9850 (65)	9000 (68.6)	8100 (71.3)
50			7450 (18.5)	7700 (39.7)	7850 (49.8)	8000 (56.6)	8150 (61.7)	8200 (65.8)	7800 (69)
55				6350 (32.1)	6500 (44.7)	6650 (52.6)	6750 (58.3)	6900 (62.9)	7000 (66.5)
60				5250 (22.3)	5450 (39.1)	5550 (48.3)	5650 (54.8)	5750 (59.8)	5850 (63.8)
65					4500 (32.6)	4650 (43.7)	4750 (51.1)	4850 (56.7)	4950 (61)
70					3750 (24.6)	3850 (38.7)	3950 (47.3)	4050 (53.4)	4150 (58.2)
75					3050 (12.3)	3200 (33.1)	3300 (43.1)	3400 (50)	3450 (55.2)
80						2600 (26.3)	2700 (38.6)	2800 (46.5)	2850 (52.2)
85						2050 (17.2)	2150 (33.6)	2250 (42.8)	2350 (49)
90							1700 (27.8)	1800 (38.7)	1850 (45.7)
95							1300 (20.4)	1400 (34.2)	1450 (42.1)
100								1000 (29)	1100 (38.3)
105								700 (22.8)	750 (34.2)
Minimum boom angle (°) for indicated length (no load)							0	22.5	34
Maximum boom length (ft) at 0° boom angle (no load)							103		

NOTE: Loads displayed in pounds. () Boom angles are in degrees.
#LMI operating code. Refer to LMI manual for operating instructions.

Lifting capacities at zero degree boom angle									
Boom angle	Main boom length in feet								
	31	43-A	55-B	67-C	79-D	91-E	103-F		
0°	19,200 (28.5)	10,550 (40.5)	6650 (52.5)	4400 (64.5)	2860 (76.5)	1700 (88.5)	900 (100.5)		

NOTE: () Reference radii in feet. 80028742

Rated Load Reductions from main boom capacity when lifting over main boom nose with ext. erected (retracted):									
(in lb.)	2300	2150	2000	1950	1900	1850	1800	1750	1700

THIS CHART IS ONLY A GUIDE AND SHOULD NOT BE USED TO OPERATE THE CRANE.

The individual crane's load chart, operating instructions and other instructional plates must be read and understood prior to operating the crane.

Load chart

127 ft main boom, full span outrigger, 360°, with stowed jib

Radius in feet	#02								
	Main boom length in feet								
	31	43-A	55-B	67-C	79-D	91-E	103-F	115-G	127
7	71,200 (73.6)								
8	69,200 (71.6)								
10	65,200 (67.6)	39,350 (74.2)							
12	53,800 (63.4)	37,350 (71.4)	38,550 (75.8)	35,600 (78.8)					
15	41,900 (56.8)	35,350 (67)	36,550 (72.6)	33,600 (76.2)	26,600 (78.6)	20,650 (80.4)			
20	30,000 (44.4)	30,650 (59.4)	31,350 (66.9)	31,600 (71.7)	23,600 (74.9)	18,650 (77.2)	15,200 (79.2)	12,250 (80.7)	
25	22,600 (27.8)	23,350 (51)	23,950 (61)	24,200 (67)	20,100 (71.1)	15,650 (74)	13,900 (76.5)	11,750 (78.4)	9300 (79.9)
30		17,400 (41.4)	18,000 (54.6)	18,300 (62.1)	18,100 (67.2)	14,850 (70.8)	12,700 (73.7)	11,550 (76)	8900 (77.9)
35		13,150 (29.4)	13,750 (47.7)	14,050 (57)	14,250 (63)	13,650 (67.4)	11,800 (70.8)	10,750 (73.7)	8500 (75.8)
40			10,80 (39.9)	11,100 (51.5)	11,250 (58.7)	11,450 (63.9)	10,900 (67.9)	9850 (71.2)	8300 (73.6)
45			8700 (31.5)	9000 (46.2)	9150 (54.6)	9350 (60.4)	9550 (65)	8750 (68.6)	7900 (71.3)
50			7000 (18.5)	7300 (39.7)	7450 (49.8)	7650 (56.6)	7850 (61.7)	7950 (65.8)	7600 (69)
55				5950 (32.1)	6100 (44.7)	6300 (52.6)	6450 (58.3)	6650 (62.9)	6800 (66.5)
60				4850 (22.3)	5050 (39.1)	5200 (48.3)	5350 (54.8)	5500 (59.8)	5650 (63.8)
65					4100 (32.6)	4300 (43.7)	4450 (51.1)	4600 (56.7)	4750 (61)
70					3350 (24.6)	3500 (38.7)	3650 (47.3)	3800 (53.4)	3950 (58.2)
75					2650 (12.3)	2850 (33.1)	3000 (43.1)	3150 (50)	3250 (55.2)
80						2250 (26.3)	2400 (38.6)	2550 (46.5)	2650 (52.2)
85						1700 (17.2)	1850 (33.6)	2000 (42.8)	2150 (49)
90							1400 (27.8)	1550 (38.7)	1650 (45.7)
95							1000 (20.4)	1150 (34.2)	1250 (42.1)
100								750 (29)	900 (38.3)
105								450 (22.8)	550 (34.2)
Minimum boom angle (°) for indicated length (no load)							0	22.5	34
Maximum boom length (ft) at 0° boom angle (no load)									103

NOTE: Loads displayed in pounds. () Boom angles are in degrees.
#LMI operating code. Refer to LMI manual for operating instructions.

Boom angle	Lifting capacities at zero degree boom angle								
	Main boom length in feet								
	31	43-A	55-B	67-C	79-D	91-E	103-F		
0°	18,400 (28.5)	9900 (40.5)	6200 (52.5)	4000 (64.5)	2460 (76.5)	1350 (88.5)	600 (100.5)		

NOTE: () Reference radii in feet.

80028746

Radius in feet	31 ft LENGTH
	#03
30	3400 (80)
46	3200 (75)
60	2700 (70)
73	2100 (65)
85	1700 (60)
96	1200 (55)
106	650 (50)
Min. boom angle for indicated length (no load)	50°
Max. boom length at 0° boom angle (no load)	79 ft

Radius in feet	55 ft LENGTH
	#04
36	2200 (80)
54	2200 (75)
70	1600 (70)
85	1000 (65)
Min. boom angle for indicated length (no load)	51.5°
Max. boom length at 0° boom angle (no load)	79 ft

80028749

NOTE: Loads displayed in pounds.
() Boom angles are in degrees.
#LMI operating code. Refer to LMI manual for operating instructions.

Boom extension capacity notes:

1. All capacities above the bold line are based on structural strength of boom extension.
2. 31 ft and 55 ft extension lengths may be used for single line lifting service.
3. Radii listed are for a fully extended boom with the boom extension erected. For main boom lengths less than fully extended, the rated loads are determined by boom angle. For boom angles not shown, use the rating of the next lower angle.
Warning: Operation of this machine with heavier loads than the capacities listed is strictly prohibited. Machine tipping with boom extension occurs rapidly and without advance warning.
4. Boom angle is the angle above or below horizontal of the longitudinal axis of the boom base section after lifting rated load.
5. Capacities listed are with outriggers properly extended and vertical jacks set.
6. When lifting over the main boom nose with 31 ft or 55 ft extension erected, the outriggers must be fully extended or 50% (17.5 ft) spread.

Radio Remote Controls – (Ground level or boom tip)

Eliminate the handling and maintenance concerns that accompany cabled remotes. Operate to a range of about 76 m (250 ft), varying with conditions.

Heavy-duty Personnel Basket –

544 kg (1200 lb) capacity steel basket with safety loops for two passengers. Gravity leveling 183 cm x 107cm (72 in x 42 in) platform. Fast attachment and secure locking systems.

Air Conditioning for Crane Cab –

Provides excellent crane cab cooling to overcome the radiant heat from the sun reflection.

Auxiliary Winch 15,000 lb Line Pull –

Second winch redundant to the main, planetary winch with boom tip “rooster sheave” to allow reeving of both winch lines.

**Spanish-Language Danger Decals,
Control Knobs, and Operators’ Manuals**

- NB4R (R4 functions)

- BSA-1
- BSA-R1 (provides rotation)
- BSAY-1
- BSAY-2

- A/C

- NBT36AW

- SDD
- SOM

Notes

Regional headquarters

Manitowoc - Americas

Manitowoc, Wisconsin, USA

Tel: +1 920 684 6621

Fax: +1 920 683 6277

Shady Grove, Pennsylvania, USA

Tel: +1 717 597 8121

Fax: +1 717 597 4062

Manitowoc - Europe, Middle East, Africa

Ecully, France

Tel: +33 (0)4 72 18 20 20

Fax: +33 (0)4 72 18 20 00

Manitowoc - Asia Pacific

Shanghai, China

Tel: +86 21 6457 0066

Fax: +86 21 6457 4955

Regional offices

Americas

Brazil

Alphaville

Mexico

Monterrey

Chile

Santiago

Europe, Middle East, Africa

Czech Republic

Netvorice

France

Baudemont

Cergy

Decines

Germany

Langenfeld

Hungary

Budapest

Italy

Lainate

Netherlands

Breda

Poland

Warsaw

Portugal

Baltar

Russia

Moscow

U.A.E.

Dubai

U.K.

Buckingham

Asia - Pacific

Australia

Brisbane

Melbourne

Sydney

China

Beijing

Chengdu

Guangzhou

India

Delhi

Hyderabad

Pune

Korea

Seoul

Philippines

Makati City

Singapore

Factories

Brazil

Alphaville

China

TaiAn

Zhangjiagang

France

Charlieu

La Clayette

Moulins

Germany

Wilhelmshaven

India

Pune

Italy

Niella Tanaro

Portugal

Baltar

Fânzeres

Slovakia

Saris

USA

Manitowoc

Port Washington

Shady Grove

This document is non-contractual. Constant improvement and engineering progress make it necessary that we reserve the right to make specification, equipment, and price changes without notice. Illustrations shown may include optional equipment and accessories and may not include all standard equipment.