

Krupp Hydraulic All-Terrain Crane
70 GMT-AT
80 ton Capacity



Superstructure Specification

Boom

38'0" - 122'0" 4 section full power boom
Telescoping cycle:

1. section 75 sec.

2. section 75 sec.

3. section 47 sec.

High speed

1. section 50 sec.

2. section 45 sec.

3. section 31 sec.

*) Jibs

33'0" swing-away lattice extension
alternatively

33'0" - 52'6" 2 stage off-set swing-away
lattice extension

Main Hoist

Axial piston motor with planetary gear
and fail safe brake

Single line pull max.: 13.700 lbs

Single line speed max.: 330 ft./min.

Drum diameter: 17"

Rope diameter: 3/4"

Rope length: 650 ft.

*) Auxiliary Hoist

Axial piston motor with planetary gear
and fail safe brake

Single line pull max.: 10.600 lbs

Single line speed max.: 420 ft./min.

Drum diameter: 13"

Rope diameter: 5/8"

Rope length: 570 ft.

Hook Blocks

70 ton 7 sheaves

*) 30 ton 3 sheaves, 10 ton single sheave,
8 ton single hook

Boom Elevation

Hydraulic cylinder with integral holding
valve

Boom angle from -1.4° to $+80^{\circ}$

Elevation cycle: 90 sec.

High speed: 50 sec.

Swing Gear

Axial piston motor with planetary gear
Holding and service brake

Swing speed: 0 - 2.5 rpm variable

Engine

6 cyl. Daimler Benz diesel OM 352A,
water-cooled, 139 hp at 2300 rpm

Tank capacity 50 gal. diesel

Hydraulic system

3 separate circuits: 2 axial piston pumps
with integrated infinitely variable speed
and load control,

1 axial piston pump

Tank capacity: 250 gal. hydraulic oil

*) Hydraulic oil cooler for extreme
working conditions

Control system

Infinite variation of all crane motions by
hydraulic pilot circuit, control levers
with automatic dead man position

Counterweight

2200 lbs permanently mounted

*) 15400 lbs, 24200 lbs

Operator's cab

Full vision, all steel, safety glass,
fully adjustable hydraulically suspended
seat, engine coolant cab heater,
complete instrumentation of engine and
crane operating controls

*) Stationary diesel cab heater

Safety installations

Anti two block and hoist rope lowering
switch, lock valves, pressure relief valves

*) Electronic load moment safety device
with automatic shut-off and digital
display of actual and permissible load,
radius and operating modes

Carrier specification

Chassis

Krupp heavy-duty 4-axle carrier, welded
box-type frame from high tensile steel

Engine

8 cyl. Daimler Benz diesel OM 422 A,
water-cooled, 330 hp at 2300 rpm

Tank capacity: 75 gal. diesel

Transmission

Automatic gear box with torque
converter

MAN 2 speed transfer case

with longitudinal differential lock

Axles

1. drive/steer axle

2. steering axle

3. drive axle

4. drive axle

Drive axles with planetary gears

Transverse differential lock on all
drive axles

*) All wheel drive and steer

Suspension

Parabolic leaf springs with hydraulic
suspension lock-out

Tyres

8 tyres 16.00 - 25

*) 20.5 - 25

Steering

ZF semi-integral ball nut hydraulic
power steering

Brakes

Service brake:

Pneumatic dual circuit brake system

Front axles with disc brakes

Rear axles with brake drums

Permanent brake:

Hydraulic retarder of automatic gear box

Auxiliary brake:

Pneumatically operated spring-loaded
brake acting on 3. and 4. axle

Driver's cab

Single cab, all steel, safety glass,
adjustable hydraulically suspended
driver's seat

Engine coolant heating system

Complete instrumentation and
driving controls

*) Stationary diesel cab heater

Outriggers

Independent horizontal and vertical
motion of each beam, operated from
crane cab and each side of chassis
Sight level device

Electrical equipment

Three phase alternator 28 V/55 A

2 batteries 12 V/180 Ah

Lights and control circuit 24 V

Performance

road speed max. 47 mph, min. 0.1 mph

Gradeability 60%, 51%, 45% dependent
on counterweight turning radius: 45 ft,
all wheel steer: 33 ft

*) Optional items

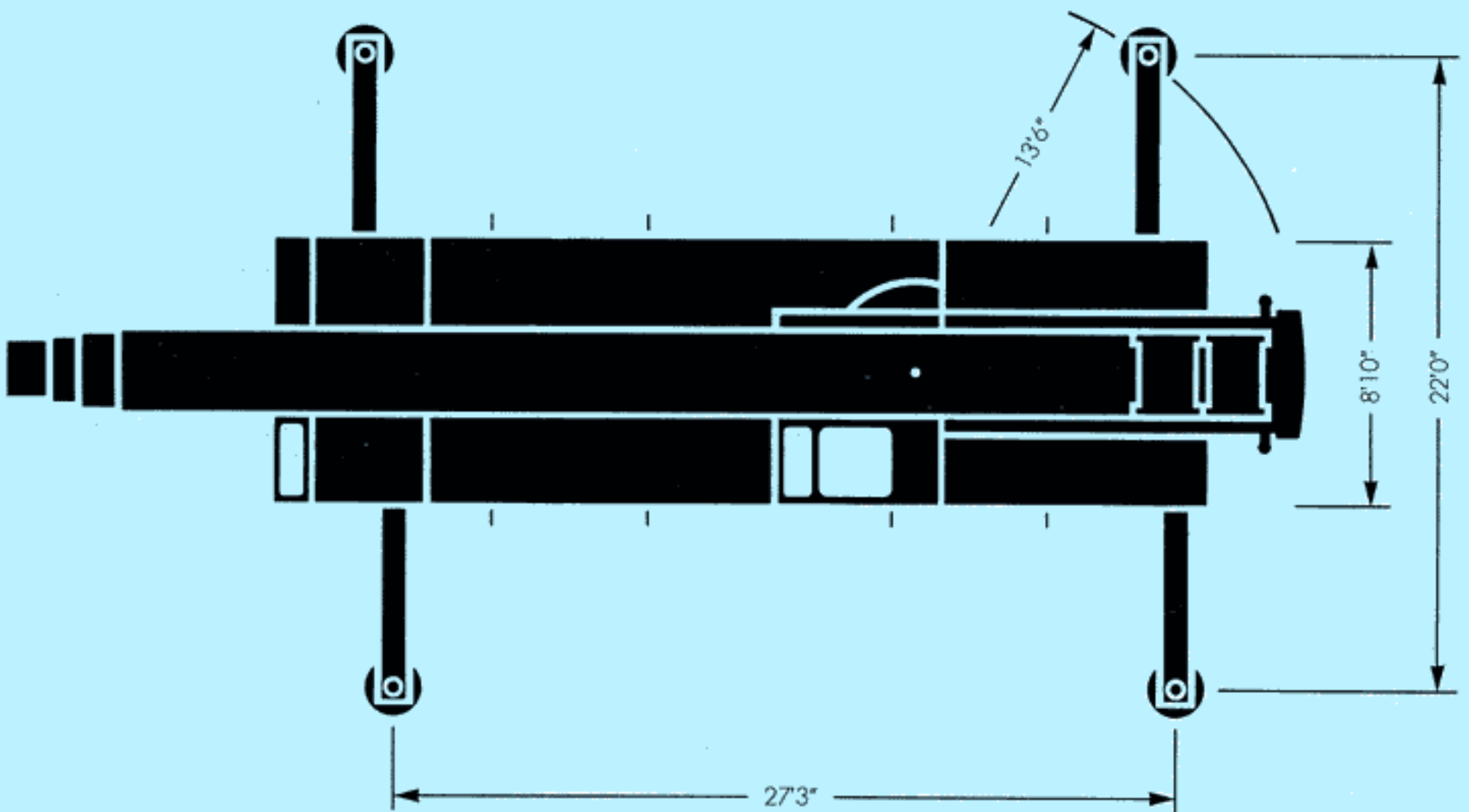
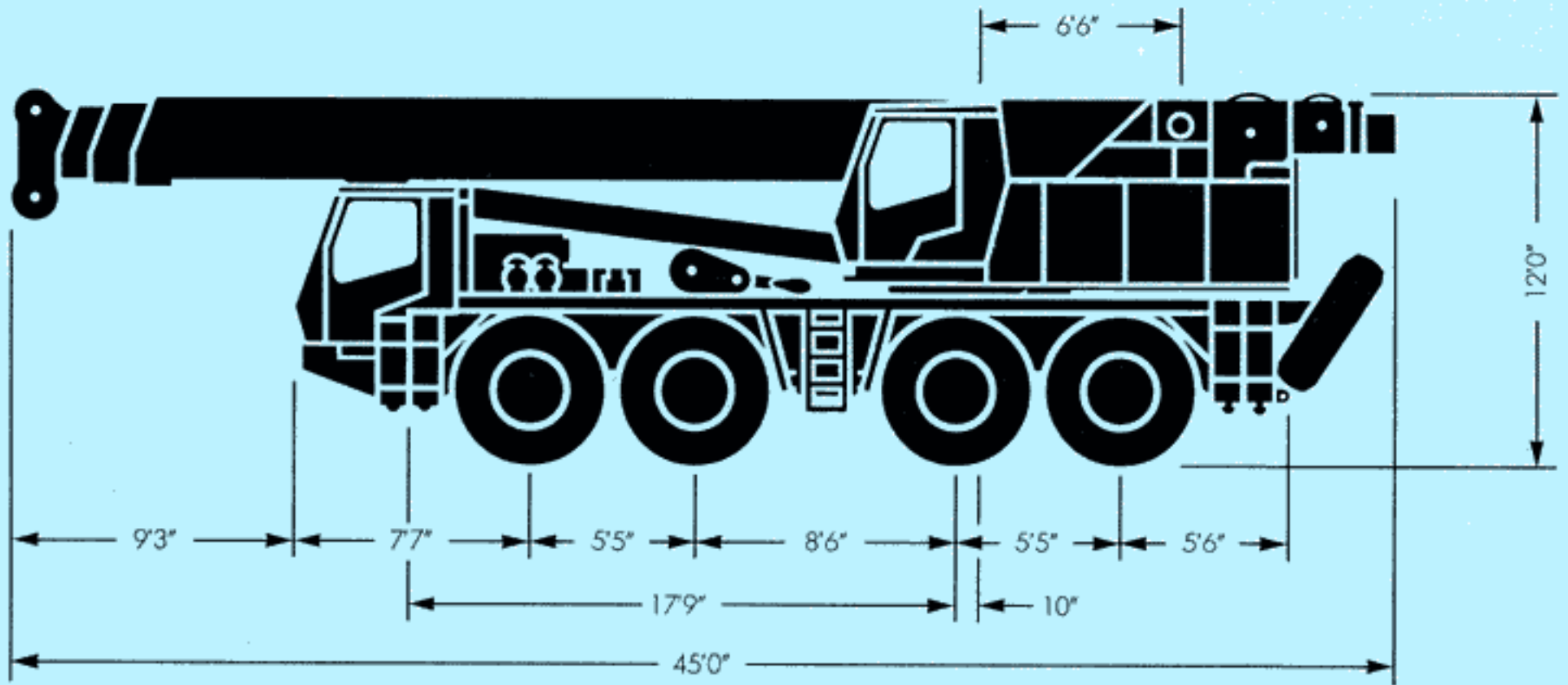

Lifting capacities in 1000 lbs

360° Main boom and swing-away lattice extension

Radius (ft)	Boom length									
	38'0"				66'0"*				93'6"	
	Hook height									
	42'0"				69'6"				97'0"	
	Counterweight									
	24.2	15.4	2.2	F	24.2	15.4	2.2	F	24.2	15.4
10**	160.0									
10	142.1	129.3	127.8	38.4						
11	134.6	118.3	116.1	36.2						
12	127.0	111.6	109.1	33.8	87.3			33.8		
13	119.3	105.7	103.6	31.8	87.3	79.4	79.4	31.8		
14	113.2	100.5	98.6	29.9	87.3	79.4	79.4	29.9		
15	107.3	95.5	93.6	28.3	87.3	79.4	79.4	28.3		
20	85.3	75.7	64.6	20.8	75.5	68.8	64.7	20.8	48.5	44.1
25	68.5	55.9	44.2	15.3	64.3	55.6	44.5	15.3	43.6	39.7
30	52.0	41.2	31.8	11.1	52.2	41.4	32.3	11.1	38.1	33.6
35					41.0	32.2	24.5	8.3	33.4	30.4
40					32.7	25.6	18.3	6.0	29.0	25.3
45					26.6	20.6	13.9	4.3	25.5	20.4
50					22.1	16.7	10.6		21.9	16.6
55					18.2	13.7	8.1		18.2	13.4
60									15.0	10.8
65									12.5	8.6
70									10.6	6.9
75									8.9	5.4
80									7.2	4.1
85										
90										
95										
100										
105										
110										
115										
120										

Notes for lifting capacities

* 66'0" boom – section 1 and 2 equally extended

*1) 117'0" boom – section 1 and 3 retracted by 2'6" ft each

F free on wheels, plus/minus 10° over rear

** over rear only

Rated loads do not exceed 85% of tipping load with the machine properly levelled on firm ground.

360° duties on outriggers fully extended, except free on wheel duties as noted.

Note counterweight required as listed in relevant lifting capacity columns.

For safe crane operation due allowance must be made to compensate for high winds, side load, pendulum action and other hazardous conditions. No side pull permitted.

Length (ft)										Radius
122'0"			117'0" + 33'0" *)				122'0" + 33'0"			
Height max. (ft)										
125'0"			153'0"				158'0"			
Capacity in 1000 lbs										Height (ft)
2.2	24.2	15.4	2.2	24.2	15.4	2.2	24.2	15.4	2.2	
										10** 10
										11 12 13 14 15
44.1 39.7 32.4 24.1 17.9		26.4 26.3 24.7 22.5	26.4 26.3 24.7 20.3	17.4 15.6 14.4	15.3 14.2 13.1	15.3 14.2 13.2	12.1 12.1 12.1	12.1 12.1	12.1 12.1	20 25 30 35 40
13.5 10.4 7.9 5.8 4.2	22.7 20.2 18.4 16.6 14.9	20.7 18.4 15.7 13.0 10.8	16.0 12.7 10.0 8.1 6.4	13.2 12.2 11.6 10.7 10.0	12.1 11.1 10.5 9.8 9.1	12.1 11.1 10.5 9.7 8.4	12.1 12.1 11.9 11.3 10.4	12.1 11.7 10.9 10.2 9.6	12.1 11.7 10.9 10.0 8.4	45 50 55 60 65
2.8	12.9 11.2 9.6 8.2 7.0	9.1 7.6 6.3 5.1 4.2	5.0 3.8 2.8	9.4 8.9 8.2 7.7 7.3	8.5 8.0 7.5 6.9 5.9	6.8 5.6 4.6 3.6 2.9	9.8 9.3 8.9 8.0 7.3	9.0 8.4 7.9 6.9 5.9	6.8 5.6 4.6 3.6 2.9	70 75 80 85 90
	5.8 5.0 4.2 3.4	3.3 2.6		6.8 6.4 5.5 4.8 4.1 3.2	5.1 4.3 3.5 3.0 2.4	2.2	6.8 6.4 5.5 4.8 4.1 3.2	5.1 4.3 3.5 2.9 2.4	2.2	95 100 105 110 115 120

Hook block and slings and/or boom attachments are considered part of the load and their weight must be deducted from the rated lifting capacity to determine the net load.

Boom must be fully extended when lifting with the swing-away extension.

Consult crane manual to determine weight reduction for load handling devices and boom attachments.

Operate crane strictly in accordance with operator's manual.

Hook elevation diagram

Main boom + 2-stage off-set lattice extension

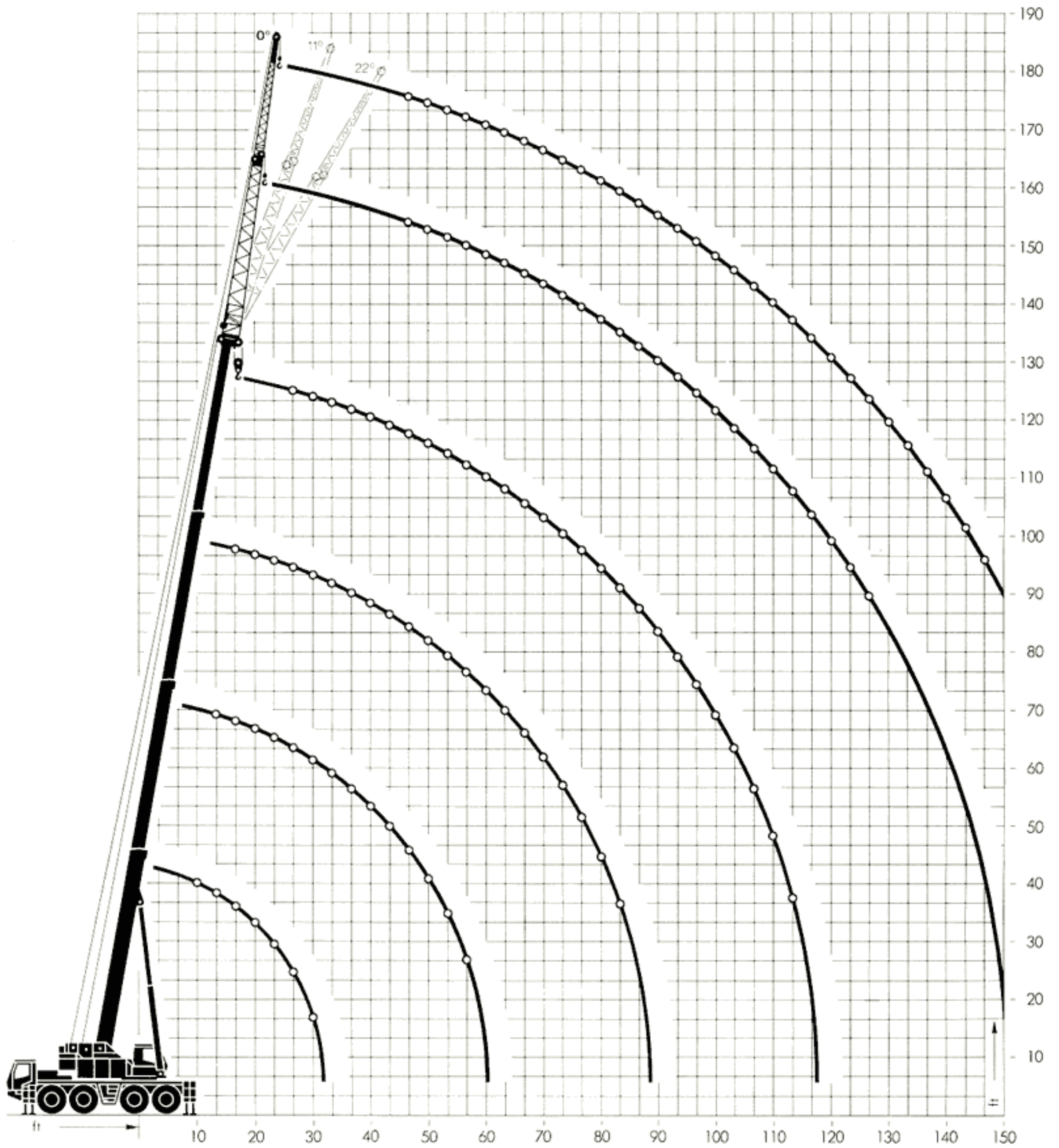

Lifting capacities in 1000 lbs on outriggers

360° Main boom with 33'0" – 52'6"

2-stage off-set swing away lattice extension

Radius (ft)	Boom length (ft)					
	122'0" + 33'0" = 155'0"			122'0" + 52'6" = 174'6"		
	Hook height max. (ft)					
	158'0"	157'0"	155'0"	178'0"	176'0"	172'0"
	Off-set angle					
	0°	11°	22°	0°	11°	22°
30	12.1					
35	12.1					
40	12.1	12.1		8.1		
45	12.1	12.0	11.1	8.1	8.1	
50	12.1	11.3	10.3	8.1	8.1	
55	11.9	10.5	9.5	8.1	7.8	6.9
60	11.3	9.8	9.0	7.8	7.4	6.5
65	10.5	9.1	8.6	7.5	7.1	6.2
70	9.8	8.7	8.0	7.2	6.8	5.9
75	9.3	8.0	7.5	6.9	6.4	5.5
80	8.9	7.7	7.2	6.5	6.1	5.2
85	8.0	7.3	6.9	6.2	5.7	4.9
90	7.4	6.9	6.5	5.8	5.2	4.7
95	6.9	6.6	6.2	5.5	4.8	4.5
100	6.4	6.3	5.9	5.3	4.6	4.3
105	5.5	5.5	5.7	5.0	4.4	4.1
110	4.9	4.9	5.1	4.7	4.2	3.9
115	4.2	4.2	4.4	4.4	4.1	3.7
120	3.3	3.3	3.8	3.8	3.8	3.5
125				3.2	3.5	3.4
130				2.7	2.9	3.1
135				2.4	2.4	2.8
140				1.9	2.0	2.2









Counterweight 24250 lbs

Hooks

Capacity	ton	70	30	10	8
Sheaves		7	3	1	0
Distance H	ft	6'0"	6'0"	5'3"	6'9"
Weight	ton	0.9	0.4	0.22	0.3

Krupp Hydraulic Mobile Cranes

Product Range

Truck Cranes	Max. lifting capacity	Max. hook height
100 GMT 	120 ton	220 ft*
180 GMT 	250 ton	320 ft*
250 GMT 	365 ton	345 ft*
350 GMT 	450 ton	365 ft*
500 GMT 	600 ton	430 ft*
All-Terrain Cranes		
25 GMT-AT 	25 ton	122 ft
35 GMT-AT 	35 ton	129 ft
70 GMT-AT 	80 ton	178 ft
140 GMT-AT 	165 ton	296 ft*

* incl. power luffing jib

Krupp Industries Inc.
 1370 Washington Pike
 Bridgeville, Pa. 15017/USA

Telephone (4 12) 221-7041
 Telex 6818083
 Telefax (4 12) 221-7684

Subject to technical modifications without notice