



AT A GLANCE:

- Rated Capacity — 17,000
- Vertical Reach — 20'0"
- Horizontal Reach — 20'2"
- Continuous rotation • 14'9" turning radius • Large Carry Deck • Hyd. outriggers •
- Built tough to work tough in industrial applications where a sure touch is needed on loads up to 8½ tons.

bmc BRODERSON
Manufacturing Corp.

P.O. Box 14770, Lenexa, Kansas 66215 • (913) 888-0606

IC-80-B

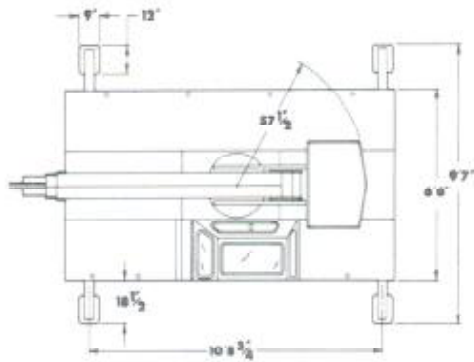
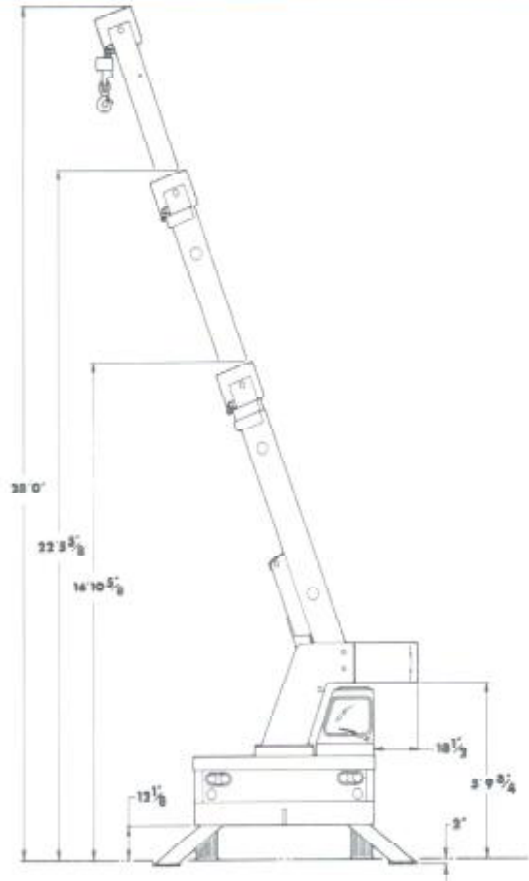
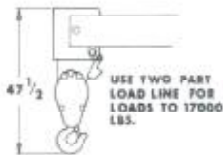
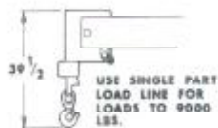
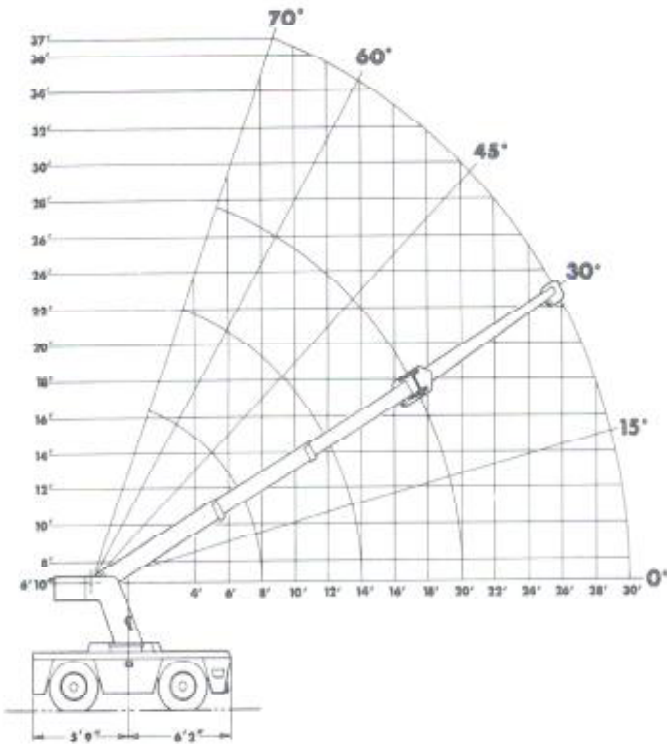

ALL CAPACITIES FOR 360° ROTATION

LOAD RADIUS FEET	3-SECTION BOOM		10' BOOM EXTENSION INSTALLED	
	ON RUBBER	ON O/R*	ON RUBBER	ON O/R*
5	9450	17000	5900	7000
6	8375	14500	5290	6000
8	6650	10250	4200	5000
10	5225	7700	3450	4000
12	4000	6550	2935	3450
14	2975	5550	2625	3050
16	2125	4450	2300	2700
18	1625	3950	1875	2250
20	1375	3550	1600	2250
22			1325	2250
24			1150	2250
26			975	2250
28			850	2125
30			700	1900

*OUTRIGGERS

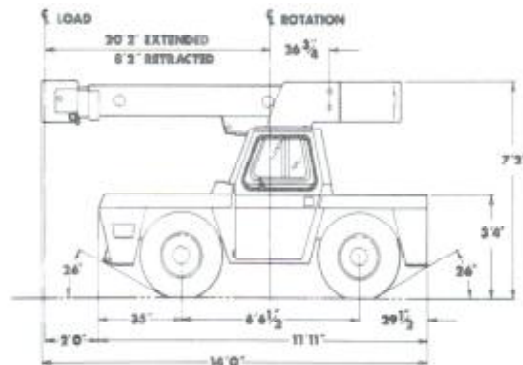

General:

Weight 13,700 lbs

Travel Speeds (calculated):

Gear	Forward	Reverse
First	5.4	4.9
Second	11	10
Third	20	18.2

Drawbar Pull:

Gear	Pounds
First	6,714*
Second	3,130
Third	1745

Turning radius

(C/L of outside steering wheel) 14'9"

Aisle width for 90° turn 10'3"

* Wheels will spin on dry concrete at 3,800 lbs.

Engine:

	Standard	Optional	Optional
Make	Continental	Perkins	Continental
Model	TM27	D4 203	TMD27
Type	Gas	Diesel	Diesel
Number of cylinders	4	4	4
Displacement	165	203	165
HP at governed RPM	64	63	58

Electrical:

12 volt system

Lighting group:

One pair headlights with Hi and Low beams, integral tail, brake and turn signals and front turn signals

Instrument group:

Fuel, ammeter, oil pressure, water temperature, converter oil temperature gauges and hourmeter

Transmission:

Make Borg Warner

Model 72T/T18

Type Reversing gear box and manual shift three speed gear box. Equipped with torque converter and transmission oil cooler.

Gear Ratio	Gear	Forward	Reverse
	First	6.324:1	6.956:1
	Second	3.092:1	3.401:1
	Third	1.686:1	1.855:1

Torque Converter: Stall ratio of 2.15:1

Axles:

Drive Axle:

Make	Rockwell
Gear ratio	7.2:1
Location	Front

Steering Axle (non-driving)

Make	Rockwell
Location	Rear

Brakes:

Service 4-Wheel drum type brakes

Parking Band type mounted on transmission

Tires:

Standard 9.00 x 15, 12-ply rating, Highway tread

Optional 10.00 x 15, 12-ply rating, Highway tread

Optional Grizzly Supersoft XS250x15 solid rubber

Fuel Tank:

20 gallon capacity

Outriggers:

Four hydraulic outriggers of box beam construction with direct connected holding valves.

Independent controls for left and right hand outriggers

Outrigger pad dimension 9" x 12"

Cargo Deck:

60 square feet

12,000 lbs. maximum capacity

Steps located on front corners

Hydraulic System:

Tandem pump, direct-driven by engine crankshaft, rated at 16 and 32.5 gpm at rated rpm

Hydraulic oil tank capacity of 17 gallons

Steering:

Full hydraulic orbitrol unit with two double acting

2 inch cylinders attached to rear axle

Crane:

Boom Movement:

Rotation Continuous

Elevation 0° to 70°

Extension 8'2" to 20'2" (12')

Boom Speeds:

Rotation 1.7 rpm

Elevation 15 seconds

Extension 28 seconds

Boom Assembly:

Three section boom assembly equipped with bearing pad, double-acting hydraulic cylinders equipped with direct-connected holding valves and boom angle indicator on each side of boom.

Boom Rotation:

Heavy-duty ball rotation gear with external teeth support boom. Rotation is powered by hydraulic motor and worm gear drive.

Boom Winch:

Turret-mounted

Hydraulic powered

Bare drum line pull of 10,000 lbs.

Winch line speed of 110 fpm

90 feet of 5/8" wire rope, downhaul weight and swivel

hook, standard

IC-80-B

Options:

Anti-Two Blocking Device

Prevents damage to hoist rope and/or crane components from pulling load hook against boom tip.

10 foot Boom Extension

Boom stowable. Fiberglass bucket(s) or work platform can be attached to boom extension tip.

Fiberglass Bucket(s)

24" x 24" x 42" deep personnel bucket with maximum capacity of 300 pounds.

Work Platform

69" x 32 1/4" x 42" deep, constructed of steel tubing with expanded metal floor. Maximum capacity of 600 pounds.

Bucket/Platform Brake

Friction brake for holding bucket(s) or Work Platform in a fixed position.

Overload Alert System

Designed to prevent excessive overloads on crane structures.

Back-Up Alarm

Provides pulsating sound when transmission is in reverse.

Auxiliary Winch

Mounted behind front bumper, hydraulically driven with control in operators console.

LP Gas Fuel System Kit

Contains all necessary components for LPG operation.

Dual Fuel System Kit

Contains all necessary components to burn LPG or gasoline.

No-Spin Differential

Differential equipped with "no-spin" feature.

Operators Guard

Tubular steel weldment with heavy expanded steel mesh top section.

Pintle Hook

Holland "T-60-A" pintle hook mounted on rear frame. 5 ton capacity.

Sheave Block

Required for maximum capacity lifts.

All Weather Cab

Rigid-mounted canopy section and removable hinged door. Includes heater 12 volt electric windshield wiper two sliding windows, one in the door and one in the right-hand side.

Defroster

Variable speed electric defroster fan inside cab.



BMC BRODERSON
Manufacturing Corp.

P.O. Box 14770, Lenexa, Kansas 66215 • (913) 888-0608

TECH
SPEC

IC-80-C



AT A GLANCE:

- Rated Capacity — 17,000 pounds
- Vertical Reach — 28' 0"
- Horizontal Reach — 20' 2"
- Continuous Rotation
- 10' 2" Turning Radius with
Optional Four Wheel Steer
- Carry Deck
- Hydraulic Outriggers

DMC BRODERSON
Manufacturing Corp.

P.O. Box 14770, Lenexa, Kansas 66215 • (913) 848-0605

IC-80-C

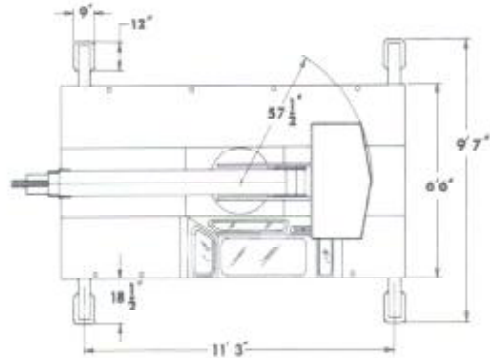
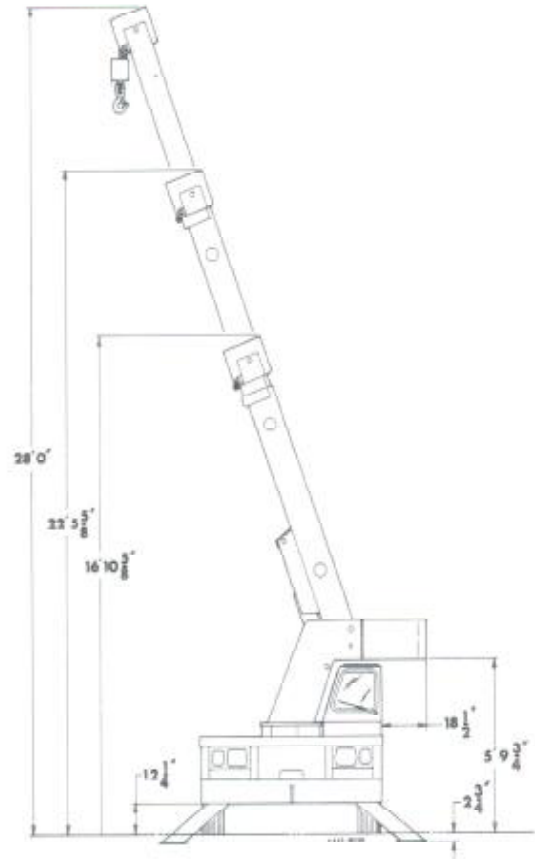
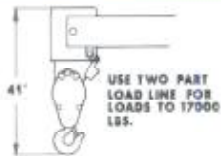
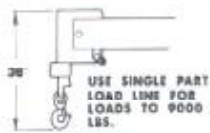
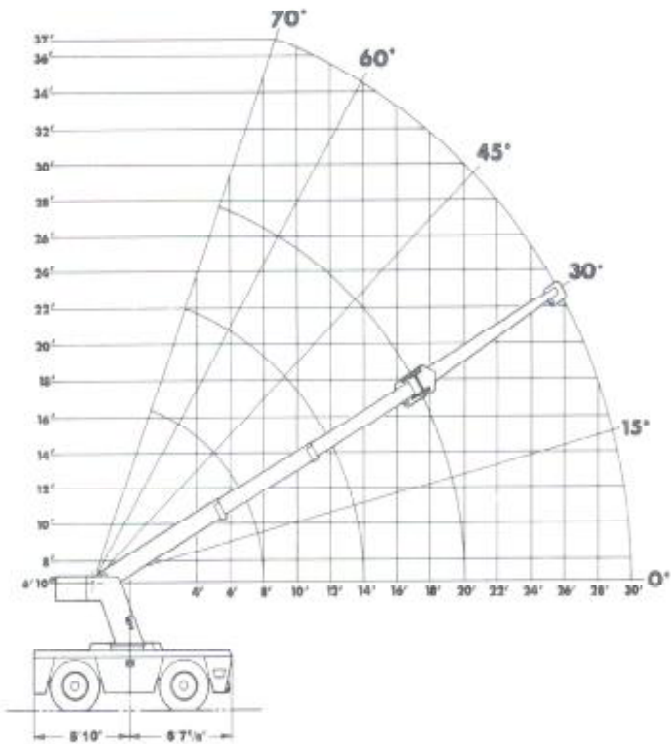

ALL CAPACITIES FOR 360° ROTATION

LOAD RADIUS FEET	3-SECTION BOOM		10' BOOM EXTENSION INSTALLED	
	ON RUBBER	ON O.R*	ON RUBBER	ON O.R*
5	9500	17000	7000	7000
6	8500	14500	6000	6000
8	5675	10250	5000	5000
10	4400	7700	4000	4000
12	3100	6550	3275	3450
14	2525	5550	2700	3050
16	2050	4450	2175	2700
18	1675	3950	1850	2250
20	1400	3550	1550	2250
22			1325	2250
24			1200	2250
26			975	2250
28			825	2150
30			675	1825

* Outrigger

Capacities on outriggers are 85% of tipping loads, capacities on rubber are 75% of tipping loads.

Capacities below **bold** line are limited by tipping. Other capacities are limited by structural or hydraulic capability.

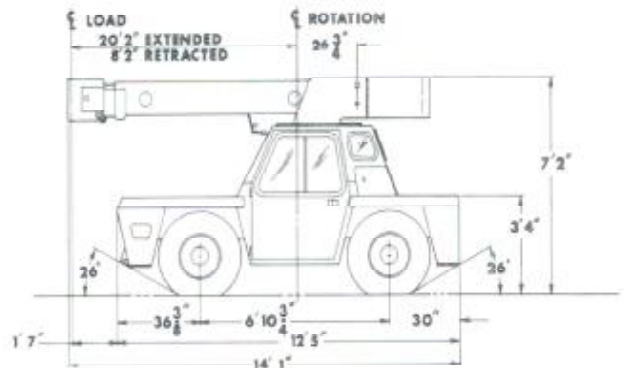

General:

	Standard Drive Axle	Optional Drive Steer Axle
Weight:	13,900 lbs.	14,200 lbs.
Travel Speeds (Calculated):		
Gear: First	5.4	3.0
Second	11.0	6.5
Third	20.0	12.0
Fourth	N/A	20.0
Gradeability:	43%	71%
Drawbar Pull:		
Gear	Pounds	Pounds
First	7,050*	11,900*
Second	3,450	5,820*
Third	1,880	3,170
Fourth	N/A	1,880
Turning Radius: (C/L of Outside Steering Wheel):	14'8"	10'2"
Aisle Width for 90° Turn:	11'9"	9'9"

* Wheels will spin before these values are reached.

Engine:

	Standard	Optional
Make	Continental	Perkins
Model	TM27	D4.203
No. of Cyl.	4	4
Displacement	165 C.I.D.	203 C.I.D.
HP at Governed Speed	64	63

Electrical:

12 Volt System

Lighting Package:

One Pair Headlights with Hi and Low Beams, Back-up Lights, Integral Tail, Brake and Turn Signals and Front turn Signals

Instrument Package:

Fuel, Ammeter, Oil Pressure, Water Temperature, Converter Oil Temperature Gauges and Hourmeter

Transmission:

Make: Borg Warner

Model: 72T/T18

Type: Reversing Gearbox and Manual Shift Three Speed Gearbox.*

Equipped with Torque Converter and Transmission Oil Cooler.

Gear Ratio:	Forward	Reverse
First	6.324:1	6.956:1
Second	3.092:1	3.401:1
Third	1.606:1	1.855:1
Fourth*	1:1	1:1

Torque Converter Has Stall Ratio of 2.15:1

* 4-speed gearbox only available with 4-wheel steer option.

Axes:

	Standard	Optional
Drive Axle:		
Make	Rockwell	Hurth
Model	F-146	272A
Gear Ratio	7.2:1	11.98:1
Location	Front	Front
Steering Axle (Non-Driving):		
Make	Rockwell	
Model	FF-931	
Location	Rear	

Brakes:

Service - 4-Wheel Drum Type Brakes

Parking - Band Type Mounted on Transmission

Tires:

Standard - 9:00x15, 12-Ply Rating, Highway Tread
 Optional - 10:00x15, 12-Ply Rating, Highway Tread
 Optional - 10:00x15, 14-Ply Rating, Mining & Industrial Tread
 Optional - Grizzley Supersoft XS250x15 Solid Rubber
 Optional - Foam Filling for the Above Pneumatic Tires

Fuel Tank:

20 Gallon Capacity

Outriggers:

Four Hydraulic Outriggers of Box Beam Construction with Direct-Connected Holding Valves. Independent Controls for Left and Right-Hand Outriggers. Outrigger Pad Dimension 9"x12".

Cargo Deck:

62 Square Feet
 12,000 pounds Capacity
 Steps Located on Front Corners

Hydraulic System:

Tandem Pump, Direct-Driven by Engine Crankshaft, Rated at 16 and 32.5 GPM at Rated RPM. Hydraulic Oil Tank Capacity of 16 Gallons.

Steering:

Standard:

Full Hydraulic Orbitrol Unit with Two Double-Acting Hydraulic Cylinders Attached to Rear Axle

Optional:

Full Hydraulic Orbitrol Unit with Two Double-Acting Hydraulic Cylinders Attached to Both Front and Rear Axles.

Steering Modes Include:

Front Steer Round Steer Crab Steer

Crane:

Boom Movement:

Rotation Continuous
 Elevation 0° to 70°
 Extension 8'2" to 20'2" (12')

Boom Speeds:

Rotation 1.5 RPM
 Elevation 10.0 Seconds
 Extension 28.0 Seconds

Boom Assembly:

Three-Section Boom Assembly Equipped with Bearing Pads, Double-Acting Hydraulic Cylinders with Direct-Connected Holding Valves and Boom Angle Indicator on Each Side of Boom.

Boom Rotation:

Heavy-Duty Ball Bearing Rotation Gear with External Teeth. Rotation is Powered by Hydraulic Motor and Worm Gear Drive.

Boom Winch:

Turret-Mounted
 Hydraulic Powered
 Bare Drum Line Pull of 10,000 Pounds
 Winch Line Speed of 110 FPM
 90 Feet of 3/16" Wire Rope, Downhaul Weight and Swivel Hook.

Anti-Two-Block Device:

An Audible and Visual Warning System to Alert the Operator if the Load Hook or Hook Block Pulls Too Close to Boom Tip.

IC-80-C

Options:

Engine:

LP Gas Fuel System Kit (2).

Contains All Necessary Components for LP Gas Operation.

Dual Fuel System Kit (3).

Contains All Necessary Components to Burn LPG or Gasoline.

Diesel Engine (4).

Perkins Model D4.203 Diesel Engine.

Spark-Arrester Muffler (5).

Installed in Addition to Standard Muffler.

Engine Shutdown Gauges (6).

Shuts Engine Off When High Water Temperature or Low Engine Oil Pressure Occurs.

Front Axle:

No-Spin Differential (Standard Axle) (7).

Differential Equipped with "No-Spin" Feature.

Four-Wheel Steering (8).

Hurth Drive/Steer Axle for Four-Wheel Steering. Differential Equipped with "No-Spin" Feature.

Tires:

10:00x15, 12-Ply Rating (9)

10:00x15, 14-Ply Rating, Mining and Industrial Tires (10).

Solid Rubber Tires (11).

Foam Filled Tires (12,13).

Foam Filling of Either 9:00 or 10:00x15 Tires.

Spare Tires and Wheels (14,15,16).

Spare Tires and Wheels are Available for All Pneumatic Tires on the IC-80.

Chassis Options:

Accessory Storage Box (17).

Storage Box is 14" Deep x 10¹/₂" Long x 27" Wide. Located in Front Carry Deck.

Auxiliary Winch (18).

Mounted Behind Front Bumper, Hydraulically Driven with Control in Operators Console.

Pintle Hook (19).

Pintle Hook Mounted on Rear Frame. 5 Ton Capacity.

Headlight and Taillight Grilles (20).

Welded Steel Protective Grilles for Headlights and Taillights.

Lifting Rings (21).

Lifting Ring at Each Corner of Carry Deck So Sling Can Be Attached for Lifting Crane.

Operators

Compartment:

Operator Guard (22).

Tubular Steel Weldment with Heavy Expanded Steel Mesh Top Section.

All-Weather Cab (23).

Rigid-Mounted Canopy Section and Removable Hinged Door. Includes Heater, Electric Wind-

shield Wiper, One Sliding Glass Window in the Door and One Fold-Out Window in Rear to Provide Flow-Through Ventilation. Defroster Fan Included.

Windshield Washer (24).

Includes Reservoir Pump and Nozzle.

Floormat (25).

Vinyl Mat with Foam Backing.

Operator Suspension Seat (26).

Provides Additional Operator Comfort.

Electrical:

Back-Up Alarm (27).

Provides Pulsating Sound when Transmission is in Reverse.

Strobe Lights (28).

Yellow Strobe Light Mounted on Each Side of Turret Weight Box.

Lighted Instrument Guages (29).

Instrument Guages Equipped with Lights for Night Operations.

Amber Rotating Beacons (30).

Amber Rotating Beacon Mounted on Each Side of Turret Weight Box.

Boom Work Lights (31).

One Work Light Mounted to Boom to Light Boom Tip and One Work Light Mounted to Turret to Light Ground Under Boom Tip.

Boom Attachments:

Anti-Two-Blocking Device (32).

Prevents Damage to Hoist Rope and/or Crane Components from Pulling Load Hook Against Boom Tip. This System uses a Weight Suspended from a Switch.

Anti-Two-Blocking Device (33).

Same as Above Except a Trip Arm is used Instead of a Weight.

10 Foot Boom Extension (34).

Boom Stowable. Fiberglass Bucket(s) or Work Platform can be Attached to Boom Extension Tip.

Fiberglass Bucket(s) (35,36).

24" x 24" x 42" Deep Personnel Bucket with Maximum Capacity of 300 Pounds.

Work Platform (37).

69" x 32⁷/₈" x 42" Deep. Constructed of Steel Tubing with Expanded-Metal Floor. Maximum Capacity of 600 Pounds.

Bucket/Platform Brake (38).

Friction Brake for Holding Bucket(s) or Work Platform in a Fixed Position.

Sheave Block (39).

Required for Maximum-Capacity Lifts.

Searcher Hook (40).

3,000 Pound Capacity, Mounts to Boom Tip.



DMC BRODERSON
Manufacturing Corp.

P.O. Box 14770, Lehi, Kansas 66215 • (913) 888-0606

IC-80-0 as per BMC

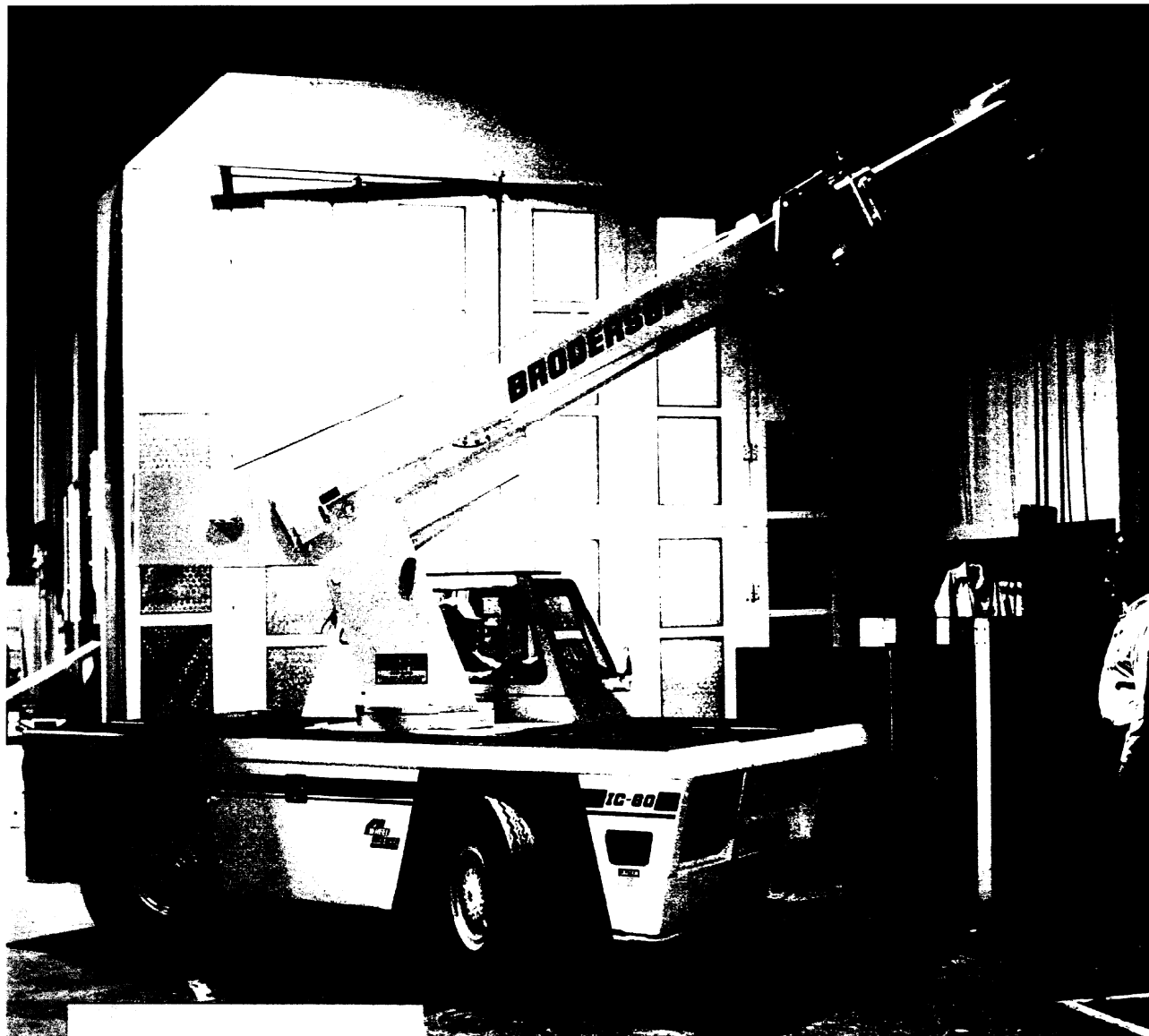

BMC BRODERSON
Manufacturing Corp.

P.O. Box 14770, Lenexa, KS 66285-4770
(913) 888-0606 • FAX (913) 541-0690

IC-80-1D

8'2"-20'2" Boom

LOAD RADIUS FEET	3-SECTION BOOM		10' BOOM EXTENSION INSTALLED	
	ON O/R*	ON RUBBER	ON O/R*	ON RUBBER
5	17000	9500	7000	7000
6	14500	8500	6000	6000
8	10250	6000	5000	5000
10	7700	4150	4000	4000
12	6550	3100	3450	3275
14	5550	2425	3050	2650
16	4450	1975	2700	2175
18	3950	1625	2250	1850
20	3550	1400	2250	1550
22			2250	1325
24			2250	1200
26			2250	975
28			2150	825
30			1825	675

1. Capacities on outriggers are 85% of tipping loads. Capacities on rubber 75% of tipping loads.
2. Deduct 120 lbs. with Boom Extension in stowed position.

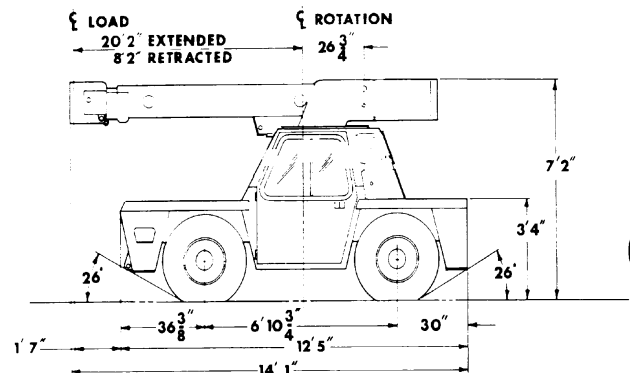
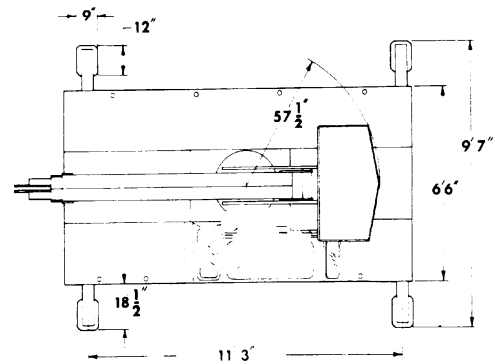
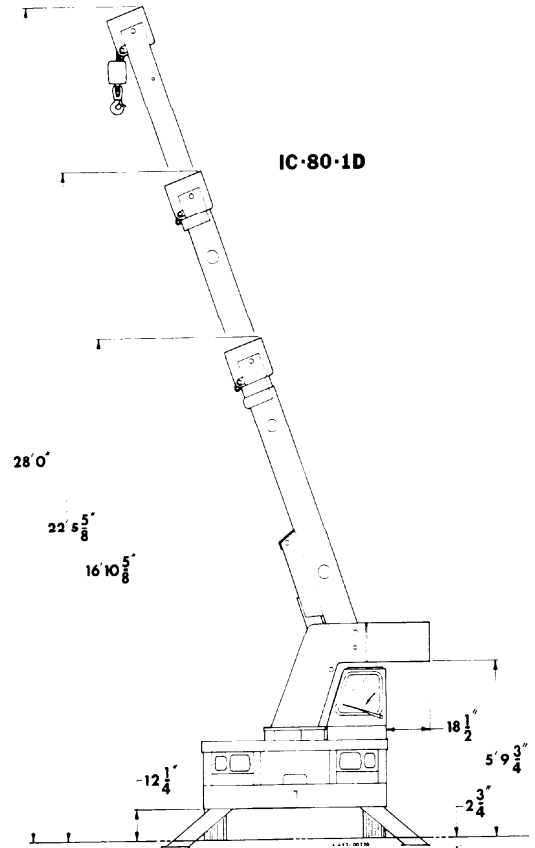
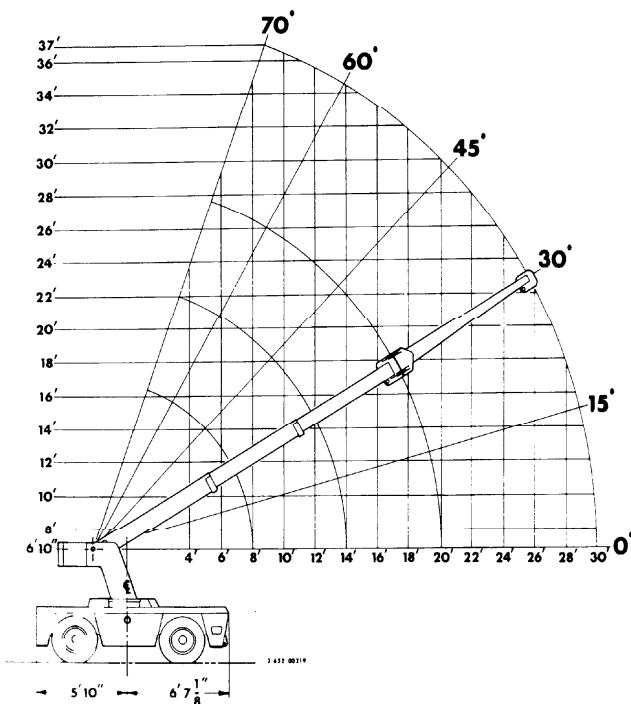
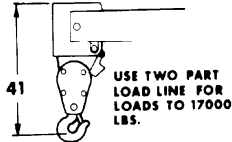
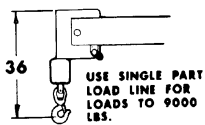

IC-80-2D

9'6"-24'0" Boom

LOAD RADIUS FEET	3-SECTION BOOM		10' BOOM EXTENSION INSTALLED	
	ON O R*	ON RUBBER	ON O R*	ON RUBBER
5	17000	9500	7000	7000
6	14500	8500	6000	6000
8	10250	6000	5000	5000
10	7700	4150	4000	4000
12	6550	3025	3450	3275
14	5550	2350	3050	2600
16	4450	1850	2700	2125
18	3950	1550	2250	1800
20	3250	1300	2250	1525
22	2075	1100	2250	1275
24	2475	925	2250	1050
26			2250	850
28			2000	700
30			1775	600
32			1625	525
34			1400	450

1. Capacities on outriggers are 85% of tipping loads. Capacities on rubber 75% of tipping loads.
2. Deduct 120 lbs. with Boom Extension in stowed position.

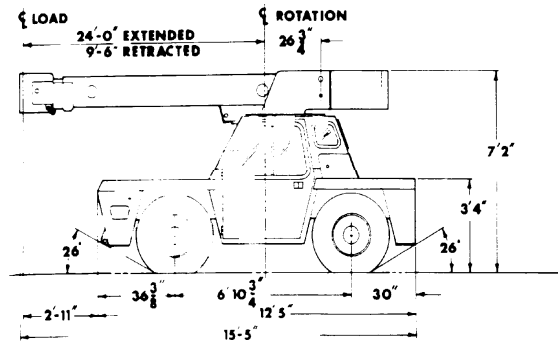
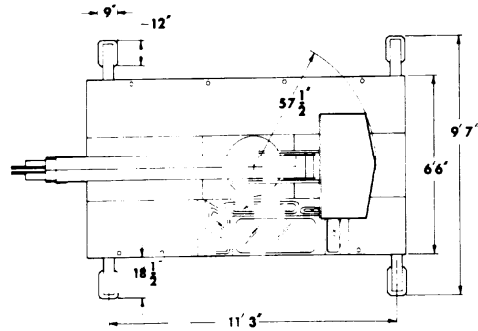
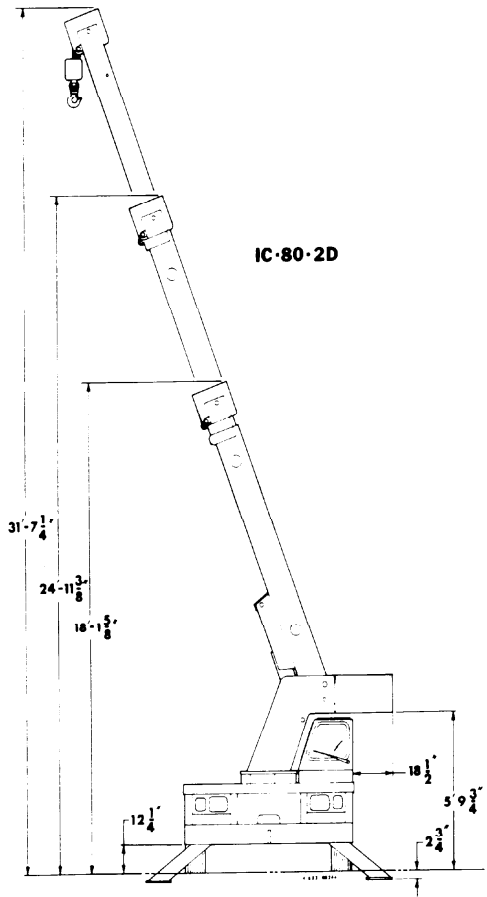
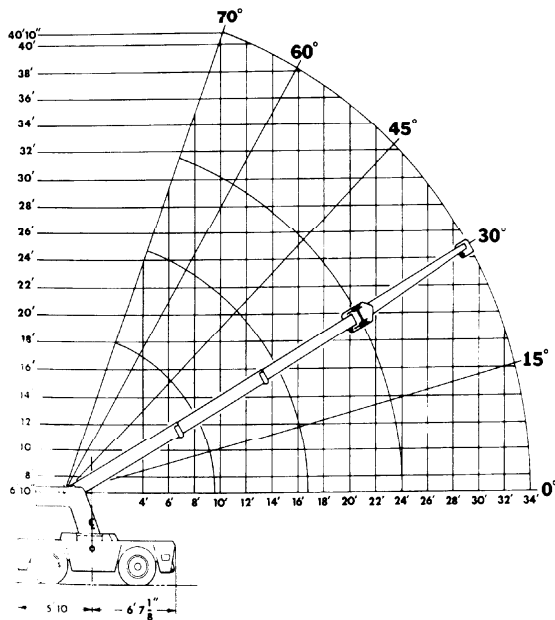
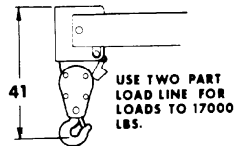
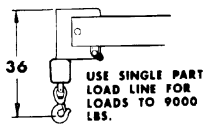

General:

	Standard Drive Axle	Optional Drive Steer Axle
Weight: IC-80-1D	14,230 lbs.	14,530 lbs.
IC-80-2D	14,530 lbs.	14,830 lbs.

Travel Speeds (Calculated):

Gear: First	5.4	3.0
Second	11.0	6.5
Third	20.0	12.0
Fourth	N/A	20.0

Gradeability:

43% 71%

Drawbar Pull:

Gear	Pounds	Pounds
First	7,050*	11,900*
Second	3,450	5,820*
Third	1,880	3,170
Fourth	N/A	1,880

Turning Radius:

(C/L of Outside Steering Wheel): 14'8" 10'2"

Aisle Width for 90° Turn: 11'9" 9'9"

Wheels will spin before these values are reached.

Engine:

	Standard	Optional	Optional	Optional
Make	Continental	John Deere	Perkins	Cummins
Model	TM27	4.239	D4.203	4B3.9
No. of Cyl.	4	4	4	4
Displacement	165 C.I.D.	239 C.I.D.	203 C.I.D.	239 C.I.D.
HP at Governed Speed	64	80	63	76

Electrical:

12 Volt System

Lighting Package:

One Pair Headlights with Hi and Low Beams, Back-up Lights, Integral Tail, Brake and Turn Signals and Front turn Signals

Instrument Package:

Fuel, Ammeter, Oil Pressure, Water Temperature, Converter Oil Temperature Gauges and Hourmeter

Back-Up Alarm

Provides pulsating sound when transmission is in reverse.

Transmission:

Make: Borg Warner

Model: 72T/T18

Type: Reversing Gearbox and Manual Shift Three Speed Gearbox.*
Equipped with Torque Converter and Transmission Oil Cooler.

Gear Ratio:	Forward	Reverse
First	6.324:1	6.956:1
Second	3.092:1	3.401:1
Third	1.686:1	1.855:1
Fourth*	1:1	1:1

Torque Converter Has Stall Ratio of 2.15:1

* 4-speed gearbox only available with 4-wheel steer option.

Axles:

Drive Axle:	Standard	Optional
Make	Rockwell	Hurth
Model	F-146	272A
Gear Ratio	7.2:1	11.98:1
Location	Front	Front

Steering Axle (Non-Driving):

Make	Rockwell
Model	FF-931
Location	Rear

Brakes:

Service - 4-Wheel Drum Type Brakes

Parking - Band Type Mounted on Transmission

Tires:

Standard - 9:00x15, 12-Ply Rating, Highway Tread

Optional - 10:00x15, 12-Ply Rating, Highway Tread

Optional - 10:00x15, 14-Ply Rating, Mining & Industrial Tread

Optional - Grizzley Supersoft XS250x15 Solid Rubber

Optional - Foam Filling for the Above Pneumatic Tires

Fuel Tank:

20 Gallon Capacity

Outriggers:

Four Hydraulic Outriggers of Box Beam Construction with Direct-Connected Holding Valves. Independent Controls for Left and Right-Hand Outriggers. Outrigger Pad Dimension 9"x12".

Cargo Deck:

62 Square Feet

12,000 pounds Capacity

Steps Located on Front Corners

Hydraulic System:

Tandem Pump, Direct-Driven by Engine Crankshaft, Rated at 16 and 32.5 GPM at Rated RPM. Hydraulic Oil Tank Capacity of 16 Gallons.

Steering:

Standard:

Full Hydraulic Orbitrol Unit with Two Double-Acting Hydraulic Cylinders Attached to Rear Axle.

Optional:

Full Hydraulic Orbitrol Unit with Two Double-Acting Hydraulic Cylinders Attached to Both Front and Rear Axles.

Steering Modes Include: Rear Wheel Steer; Round Steer

Crane:

Boom Movement:	IC-80-1D	IC-80-2D
Rotation	Continuous	Continuous
Elevation	0° to 70°	0° to 70°
Extension	8'2" to 20'2" (12')	9'6" to 24'

Boom Speeds:

Rotation	1.7 RPM	1.7 RPM
Elevation	10.0 Seconds	10.0 Seconds
Extension	28.0 Seconds	34.0 Seconds

Boom Assembly:

Three-Section Boom Assembly Equipped with Bearing Pads, Double-Acting Hydraulic Cylinders with Direct-Connected Holding Valves and Boom Angle Indicator on Each Side of Boom.

Boom Rotation:

Heavy-Duty Ball Bearing Rotation Gear with External Teeth. Rotation is Powered by Hydraulic Motor and Worm Gear Drive.

Boom Winch:

Turret-Mounted
Hydraulic Powered
Bare Drum Line Pull of 10,000 Pounds
Winch Line Speed of 110 FPM
IC-80-1D—90 feet of ⁹/₁₆" Wire Rope
IC-80-2D—105 feet of ⁹/₁₆" Wire Rope
Downhaul Weight and Swivel Hook

Anti-Two Block Device:

Prevents damage to hoist rope and/or crane components from pulling load hook against tip.

2-Part-Line Sheave Block:

Single sheave block for two part line requirements.

Listed below are brief descriptions of each option available for the IC-80-D Industrial crane.
Consult the IC-80-D Engineering Spec for additional information on each option.

1. IC-80-1D Industrial Crane with 8'2"-20'2" Boom
2. IC-80-2D Industrial Crane with 9'6"-24' Boom

ENGINE OPTIONS:

3. LP Gas Fuel System
Contains all necessary components for LP gas operations
4. Dual Fuel System
Contains all necessary components to burn LP gas and gasoline.

Diesel Engines:

5. John Deere
4-cylinder, Model 4239D
6. Perkins
4-cylinder, Model D4.203
7. Cummins
4-cylinder, Model 4B3.9
8. Spark Arrester Muffler
Installed in addition to standard muffler.
9. Catalytic Converter
Reduces engine emissions, Cummins Diesel only.
10. Engine Heater
Engine coolant heater installed to circulate warm water through engine, plugs into 120 volt AC.
11. Ether Injection System
Ether starting aid controlled by switch in operator compartment and injects ether directly into intake manifold, Cummins Diesel only.
12. Engine Shut Down Gauges
Shuts engine off when high water temperature or low engine oil pressure occurs.

FRONT AXLE OPTIONS:

13. No-Spin Differential
The differential equipped with "No-Spin" feature.
14. Four-Wheel Steering
Hurth drive/steer axle for four-wheel steering, differential equipped with "No-Spin" feature.

TIRE OPTIONS:

15. 10.00 x 15, 12-Ply Rating
16. Solid Rubber Tires
17. 10.00 x 15, 14-Ply Rating, Mining & Industrial Tires

FOAM FILLING OF TIRES:

18. 9.00 x 15 Tires
19. 10.00 x 15 Tires

SPARE TIRE AND WHEELS:

20. 9.00 x 15
21. 10.00 x 15
22. 10.00 x 15 Mining & Industrial

CHASSIS OPTIONS:

23. Accessory Storage Box
Storage box is 14" deep x 10-1/2" long and 27" wide, located in front carry deck.

24. Auxiliary Winch
Mounted behind front bumper, hydraulically driven with control in operator's console.
25. Pintle Hook
Pintle hook mounted on rear frame, 5-ton capacity.
26. Headlight and Taillight Grilles
Welded steel protective grilles for headlight and taillights.
27. Rearview Mirrors
One mounted on right-hand deck stake and one mounted on left-hand deck stake.
28. Lifting Rings
Lifting rings at each corner of carry deck so sling can be attached for lifting crane.

OPERATOR COMPARTMENT OPTIONS:

29. Operator Guard
Tubular steel weldment with heavy expanded steel mesh top section.
30. All-Weather Cab
Rigid-mounted canopy section and removable hinged door. Includes heater, electric windshield wiper, one sliding glass window in the door and one fold-out window in rear to provide flow-through ventilation. Defroster fan included.
31. Sliding Right-Hand Window
Window on right-hand side of cab slides open for additional ventilation.
32. Windshield Washer
Includes reservoir pump and nozzle.
33. Floor Mat
Vinyl mat with foam backing.
34. Operator Suspension Seat
Provides additional operator comfort.
35. Noise Reduction Kit
Includes floor mat, control valve and side panels of foam backed vinyl for noise reduction.

ELECTRICAL OPTIONS:

36. Outrigger Warning System
Two-tone alarm is activated when "outrigger down" controls are operated.
37. Strobe Lights
Yellow strobe light mounted on each side of turret weight box.
38. Lighted Instrument Gauges
Instrument gauges equipped with lights for night operations.
39. Amber Rotating Beacons
Amber rotating beacon mounted on each side of turret weight box.
40. Boom Work Lights
One work light mounted to boom to light boom tip and one work light mounted to turret to light ground under boom tip.
41. Boom Work Lights and Beacons
Boom work lights and amber rotating beacons installed.

42. Boom Work Lights and Strobe
Boom work lights and strobe lights installed.
43. Dome Light
Interior light installed for units equipped with an all weather cab.

HYDRAULIC OPTIONS:

44. Boom Structural Protection System
Important to understand fully the description of the Boom Structural Protection System described in the IC-80 Engineering Spec. This option is not intended to and will not replace an LMI.
45. Outrigger Control - Individual
Electric switch used in conjunction with existing two outrigger valve section to select for individual operation of each outrigger.

BOOM ATTACHMENTS:

46. Anti-Two Block - Chain & Weight
Prevents damage to hoist rope and/or crane components from pulling load hook against boom tip. This system uses a suspended weight on the boom tip instead of a trip arm.
47. Boom Extension, 10 Foot Boom Stowable, Fiberglass bucket(s) or work platform can be attached to the boom extension tip.
48. Boom Extension, 10 Foot, Offsettable
Same as item 47, except the boom extension is offsettable to 3 different positions; 0 degree (inline), 15 degree and 30 degree offset.
49. Searcher Hook - "H" Shape
Swivel hook with spring latch hangs from link under boom tip, 5,000 pound capacity.
50. Searcher Hook - Large
Swivel hook with spring latch hangs from support structure projecting outward from boom tip, 5,000 pound capacity.
51. Load Moment Indicator - Krueger
Warns operator of impending overload with audible and visual signals. Prevents overload by stopping boom functions that cause overloads. Readouts for load, boom angle, boom length, and load radius.
52. Load Indicator - Krueger
Includes 3-sheave load sensor on top of boom and readout box on top of instrument panel.
53. Load Moment Indicator - PAT
Same as item 51, except manufactured by PAT.
54. Load Indicator - PAT
Same as item 52, except manufactured by PAT.



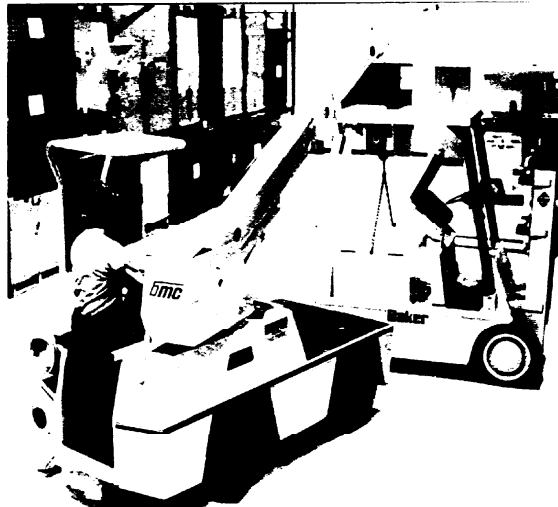
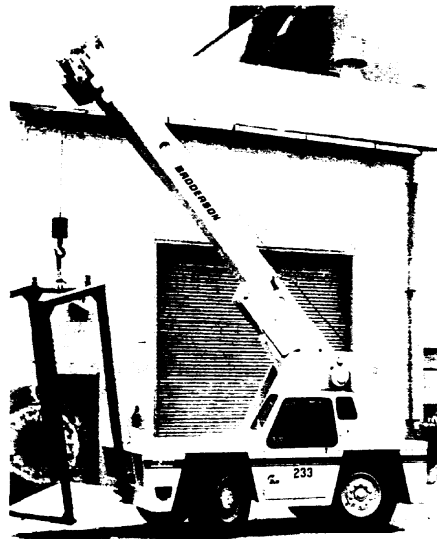
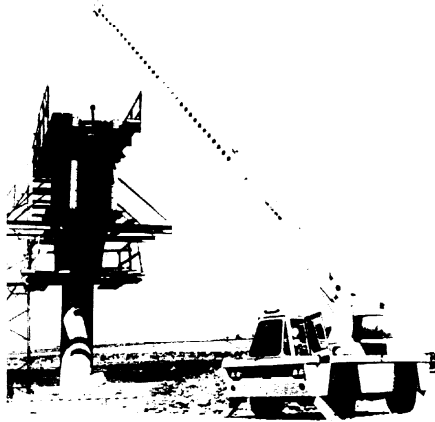

DMC BRODERSON
Manufacturing Corp.

P.O. Box 14770, Lenexa, KS 66285-4770
(913) 888-0606 • FAX (913) 541-0690



DMC BRODERSON
Manufacturing Corp.

P.O. Box 14770, Lenexa, KS 66285-4770
(913) 888-0606 • FAX (913) 541-0690
• FAX (913) 888-8431 • Sales

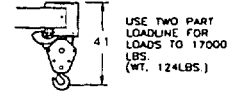
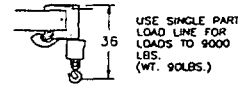
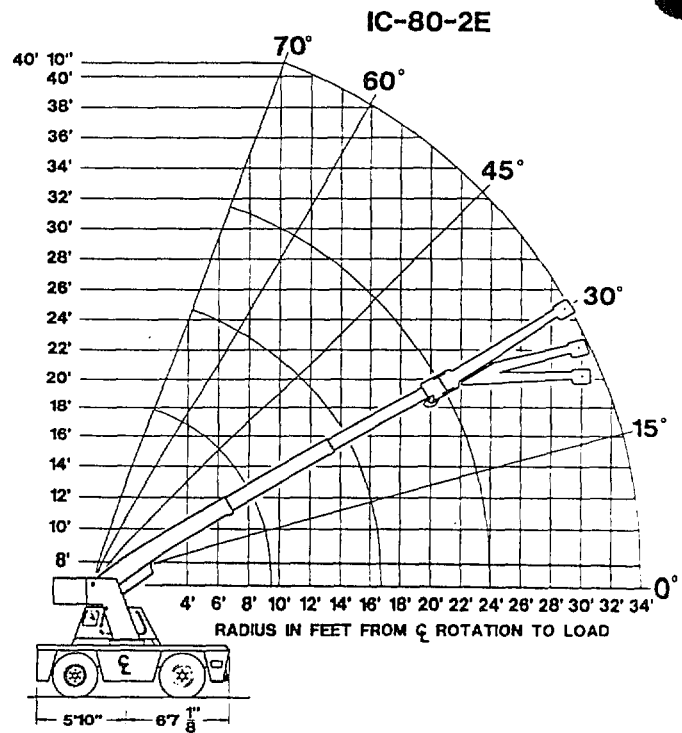
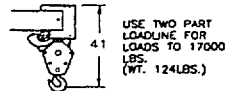
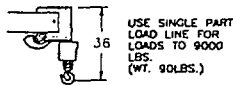
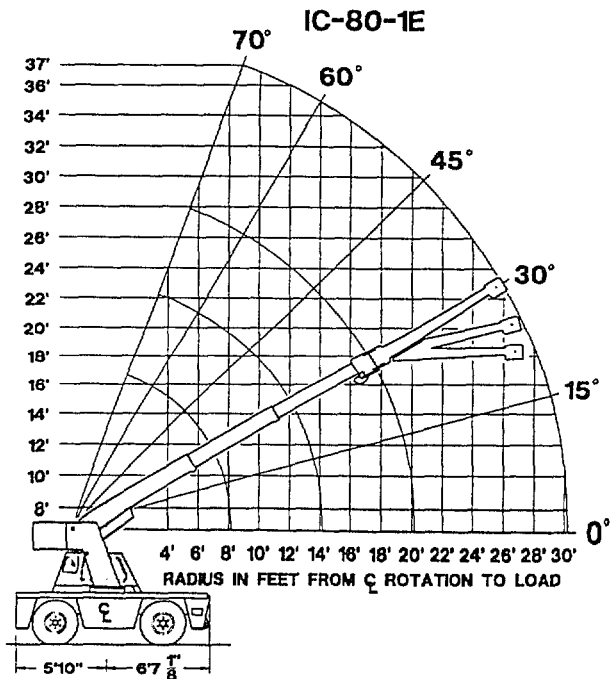

IC-80-1E

CAPACITIES APPLY TO OPERATION ON FIRM LEVEL SURFACE					
LOAD RADIUS FEET	MAIN BOOM OR EXTENSION CAPACITIES IN POUNDS				
	360° ROTATION		OVER FRONT		
	ON RUBBER	ON OUTRIGGERS	ON RUBBER	ON OUTRIGGERS	
5	9600	17000	11700	17000	
6	7900	14500	10400	14500	
8	5750	10250	8400	10250	
10	4150	7700	6300	7700	
12	3100	6550	4650	6550	
14	2425	5550	3650	5550	
16	1975	4650	3000	4650	
18	1625	3950	2500	4150	
20	1400	3550	2150	3800	
22	1275	3000	1900	3000	
24	1075	2750	1650	2800	
26	925	2450	1425	2600	
28	775	2150	1250	2400	
30	675	1950	1100	2250	
10-FOOT BOOM EXTENSION - STRAIGHT OR OFFSET					
MAIN BOOM ANGLE					
ANGLE	0°	30°	45°	60°	70°
• 1 0°	2250	2600	3200	5000	7000
115°	---	2400	2700	3500	4200
130°	---	2250	2500	3000	3300

* USE 0° FOR STRAIGHT BOOM EXTENSION
 † USE 0°, 15° OR 30° FOR OFFSET BOOM EXTENSION
 BOOM EXT. LOADS MUST NOT EXCEED MAIN BOOM CAPACITY.

Capacities on outriggers are 85% of tipping loads. Capacities on rubber are 75% of tipping loads. Capacities below **BOLD** line are limited by tipping. Other capacities are limited by structural or hydraulic capabilities. Deduct 120 pounds with Boom Extension in stowed position.

IC-80-2E

CAPACITIES APPLY TO OPERATION ON FIRM LEVEL SURFACE					
LOAD RADIUS FEET	MAIN BOOM OR EXTENSION CAPACITIES IN POUNDS				
	360° ROTATION		OVER FRONT		
	ON RUBBER	ON OUTRIGGERS	ON RUBBER	ON OUTRIGGERS	
5	9500	17000	11600	17000	
6	7800	14500	10200	14500	
8	5500	10250	8250	10250	
10	3900	7700	6200	7700	
12	2900	6550	4550	6550	
14	2300	5550	3550	5550	
16	1850	4550	2850	4550	
18	1550	3950	2400	4050	
20	1300	3250	2050	3650	
22	1100	2875	1750	3300	
24	925	2475	1550	3100	
26	850	2250	1350	2750	
28	700	2000	1175	2500	
30	600	1775	1025	2300	
32	500	1625	900	2100	
34	425	1400	800	1950	
10-FOOT BOOM EXTENSION - STRAIGHT OR OFFSET					
MAIN BOOM ANGLE					
ANGLE	0°	30°	45°	60°	70°
• 1 0°	2250	2600	3200	5000	7000
115°	---	2400	2700	3500	4200
130°	---	2250	2500	3000	3300

* USE 0° FOR STRAIGHT BOOM EXTENSION
 † USE 0°, 15° OR 30° FOR OFFSET BOOM EXTENSION
 BOOM EXT. LOADS MUST NOT EXCEED MAIN BOOM CAPACITY.

Capacities on outriggers are 85% of tipping loads. Capacities on rubber are 75% of tipping loads. Capacities below **BOLD** line are limited by tipping. Other capacities are limited by structural or hydraulic capabilities. Deduct 120 pounds with Boom Extension in stowed position.

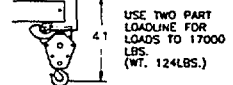
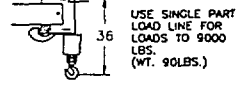
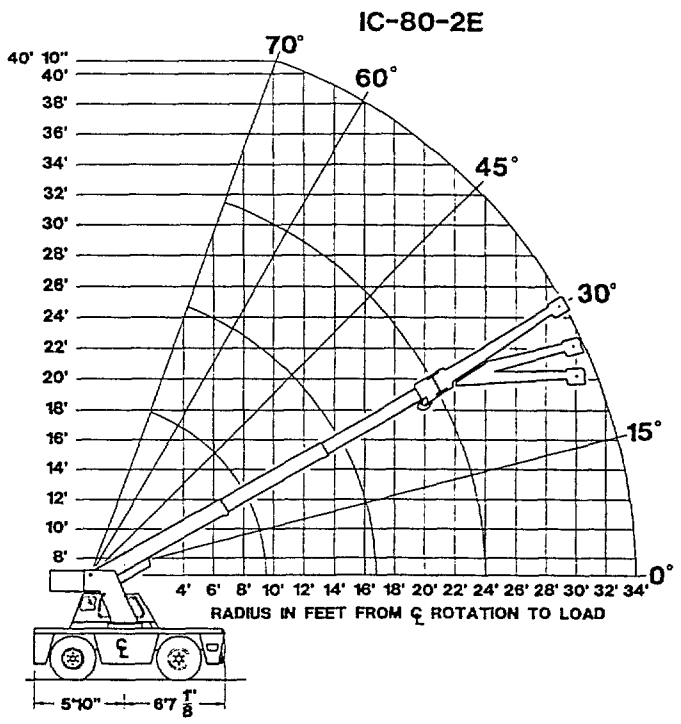
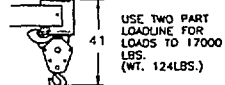
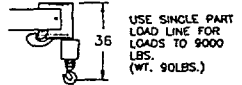
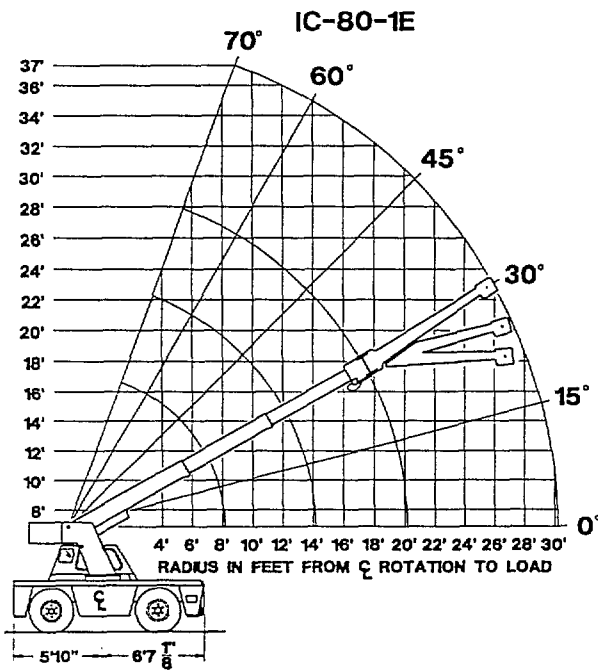

IC-80-1E

IC-80-2E

CAPACITIES APPLY TO OPERATION ON FIRM LEVEL SURFACE						
LOAD RADIUS FEET	MAIN BOOM OR EXTENSION CAPACITIES IN POUNDS					
	360° ROTATION		OVER FRONT			
	ON RUBBER	ON OUTRIGGERS	ON RUBBER	ON OUTRIGGERS		
5	9600	17000	11700	17000		
6	7900	14500	10400	14500		
8	5750	10250	8400	10250		
10	4150	7700	6300	7700		
12	3100	6550	4650	6550		
14	2425	5550	3650	5550		
16	1975	4650	3000	4650		
18	1625	3950	2500	4150		
20	1400	3550	2150	3800		
22	1275	3000	1900	3000		
24	1075	2750	1650	2800		
26	925	2450	1425	2600		
28	775	2150	1250	2400		
30	675	1950	1100	2250		
10' BOOM EXT.	10-FOOT BOOM EXTENSION - STRAIGHT OR OFFSET					
	MAIN BOOM ANGLE					
	ANGLE	0°	30°	45°	60°	70°
	* 1 0'	2250	2600	3200	5000	7000
	115'	---	2400	2700	3500	4200
130'	---	2250	2500	3000	3300	

CAPACITIES APPLY TO OPERATION ON FIRM LEVEL SURFACE						
LOAD RADIUS FEET	MAIN BOOM OR EXTENSION CAPACITIES IN POUNDS					
	360° ROTATION		OVER FRONT			
	ON RUBBER	ON OUTRIGGERS	ON RUBBER	ON OUTRIGGERS		
5	9500	17000	11600	17000		
6	7800	14500	10200	14500		
8	5500	10250	8250	10250		
10	3900	7700	6200	7700		
12	2900	6550	4550	6550		
14	2300	5550	3550	5550		
16	1850	4550	2850	4550		
18	1550	3950	2400	4050		
20	1300	3250	2050	3650		
22	1100	2875	1750	3300		
24	925	2475	1550	3100		
26	850	2250	1350	2750		
28	700	2000	1175	2500		
30	600	1775	1025	2300		
32	500	1625	900	2100		
34	425	1400	800	1950		
10' BOOM EXT.	10-FOOT BOOM EXTENSION - STRAIGHT OR OFFSET					
	MAIN BOOM ANGLE					
	ANGLE	0°	30°	45°	60°	70°
	* 1 0'	2250	2600	3200	5000	7000
	115'	---	2400	2700	3500	4200
130'	---	2250	2500	3000	3300	

* USE 0° FOR STRAIGHT BOOM EXTENSION
 † USE 0°, 15° OR 30° FOR OFFSET BOOM EXTENSION
 BOOM EXT. LOADS MUST NOT EXCEED MAIN BOOM CAPACITY.

* USE 0° FOR STRAIGHT BOOM EXTENSION
 † USE 0°, 15° OR 30° FOR OFFSET BOOM EXTENSION
 BOOM EXT. LOADS MUST NOT EXCEED MAIN BOOM CAPACITY.

Capacities on outriggers are 85% of tipping loads. Capacities on rubber are 75% of tipping loads. Capacities below BOLD line are limited by tipping. Other capacities are limited by structural or hydraulic capabilities. Deduct 120 pounds with Boom Extension in stowed position.

Capacities on outriggers are 85% of tipping loads. Capacities on rubber are 75% of tipping loads. Capacities below BOLD line are limited by tipping. Other capacities are limited by structural or hydraulic capabilities. Deduct 120 pounds with Boom Extension in stowed position.

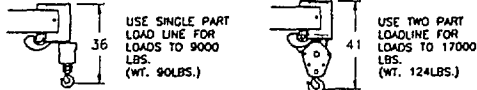
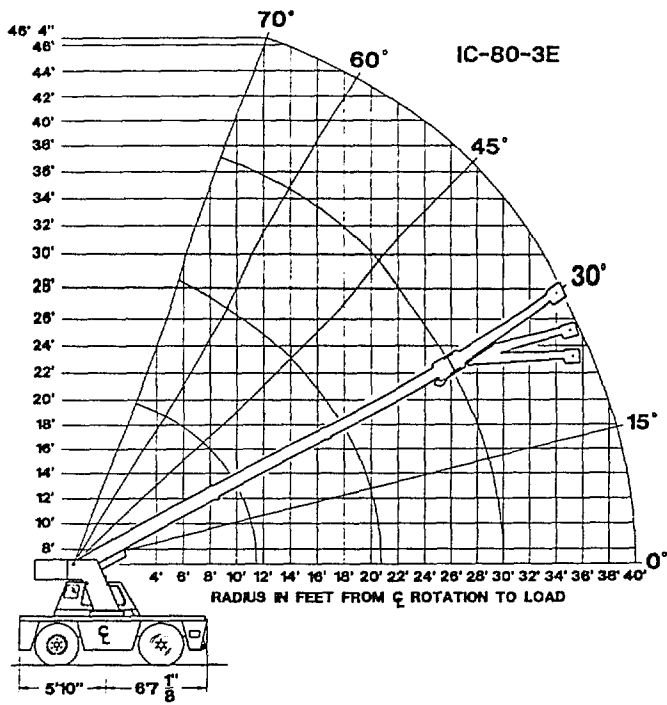

IC-80-3E

CAPACITIES APPLY TO OPERATION ON FIRM LEVEL SURFACE					
LOAD RADIUS FEET	MAIN BOOM OR EXTENSION CAPACITIES IN POUNDS				
	360° ROTATION		OVER FRONT		
	ON RUBBER	ON OUTRIGGERS	ON RUBBER	ON OUTRIGGERS	
5	9400	17000	11400	17000	
6	7550	14000	10000	14000	
8	5250	10000	8100	10000	
10	3600	7700	6100	7700	
12	2650	6100	4450	6100	
14	2050	5200	3400	5200	
16	1600	4400	2700	4400	
18	1250	3650	2200	3900	
20	1050	3050	1800	3400	
22	850	2650	1550	3050	
24	750	2300	1350	2800	
26	650	2050	1150	2550	
28	550	1850	1000	2350	
30	450	1650	900	2150	
32	350	1550	750	1950	
34	250	1400	650	1800	
36	200	1250	550	1650	
38	150	1100	450	1500	
40	100	1000	400	1400	
10' BOOM EXT.	10-FOOT BOOM EXTENSION - STRAIGHT OR OFFSET				
	MAIN BOOM ANGLE				
	ANGLE	0°	30°	45°	60°
	11 0°	2250	2600	3200	5000
	11 15°	---	2400	2700	3500
	11 30°	---	2250	2500	3000

* USE 0° FOR STRAIGHT BOOM EXTENSION
 † USE 0°, 15° OR 30° FOR OFFSET BOOM EXTENSION
 BOOM EXT. LOADS MUST NOT EXCEED MAIN BOOM CAPACITY.

Capacities on outriggers are 85% of tipping loads. Capacities on rubber are 75% of tipping loads. Capacities below BOLD line are limited by tipping. Other capacities are limited by structural or hydraulic capabilities. Deduct 120 pounds with Boom Extension in stowed position.

	IC-80-1E	IC-80-2E	IC-80-3E
A	28' 2"	31' 9"	37' 5"
B	22' 6"	25' 0"	28' 9"
C	16' 11"	18' 2"	20' 0"
D	20' 2"	24' 0"	30' 0"
E	8' 2"	9' 6"	11' 6"
F	1' 7"	2' 11"	4' 11"
G	14' 1"	15' 5"	17' 5"

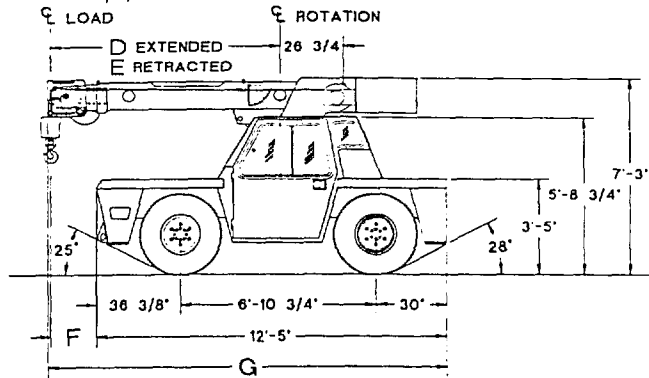
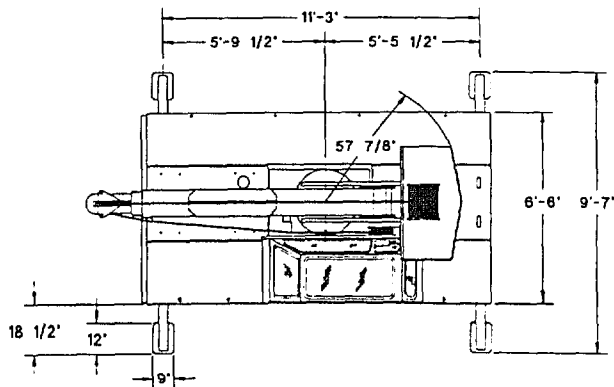
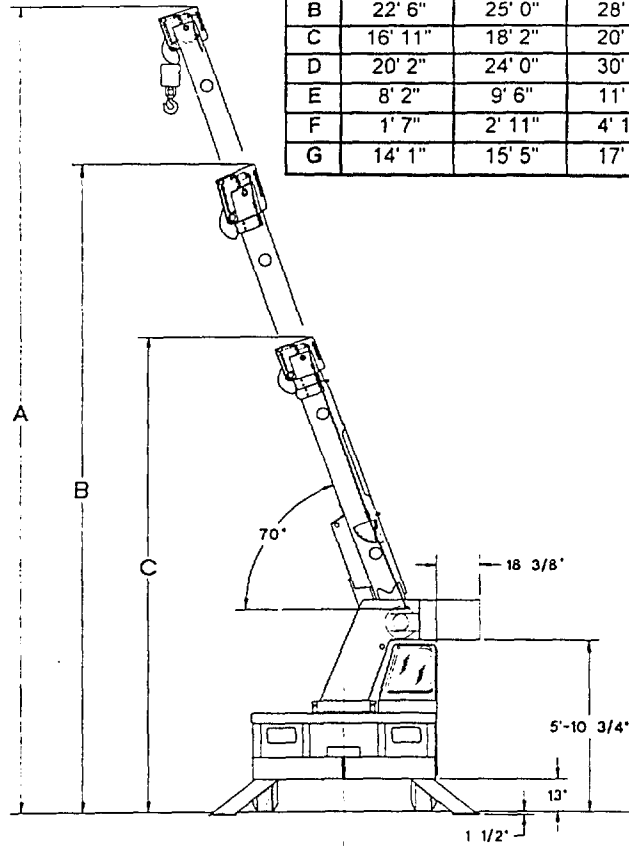

Listed below are brief descriptions of each option available for the IC-80-E Industrial Cranes.
Consult the IC-80-E Engineering Spec for additional information on each option.

MODELS:

1. IC-80-1E Industrial Crane with 8'2"-20'2" Boom
2. IC-80-2E Industrial Crane with 9'6"-24' Boom
3. IC-80-3E Industrial Crane with 11'6"-30' Boom

ENGINE:

5. **LP Gas Fuel System**
Contains all necessary components for LP gas operations.
6. **Dual Fuel System**
Contains all necessary components to burn LP gas and gasoline.
Diesel Engines:
7. **Cummins**
4-cylinder, Model 4B3.9 7.
8. **Perkins**
4-cylinder, Model D4.236
9. **John Deere**
4-cylinder, Model 4239D
10. **Spark Arrester Muffler**
Installed in addition to std. muffler.
11. **Catalytic Converter**
Reduces engine emissions, Diesel only.
- Engine Heater**
Engine coolant heater installed to circulate warm water through engine, plugs into 120 volt AC.
13. **Ether Injection System**
Ether starting aid controlled by switch in operator compartment and injects ether directly into intake manifold.
14. **Engine Shut Down Gauges**
Shuts engine off when high water temperature or low engine oil pressure occurs.

FRONT AXLE OPTIONS:

16. **Four-Wheel Steering**
Hurth drive/steer axle for four-wheel steering, differential equipped with Limited Slip Differential.

TIRE OPTIONS:

- Solid Rubber Tires:**
18. 8.25 x 15
 19. Low Profile
 20. 10.00 x 15, 14-Ply Rating, Mining & Industrial Tires
 21. 10.00 x 15 Tires, Foam Filled
- SPARE TIRE AND WHEELS:**
22. 10.00 x 15, 14-ply, Highway Tread
 23. 10.00 x 15 Mining & Industrial

CHASSIS OPTIONS:

- Outrigger Control - Selector**
Provide electric selector valves with existing two controls for individual operation.

CHASSIS OPTIONS: Cont'd

26. **Outrigger Control - Individual**
Provides four controls for individual outrigger operations.
27. **Auxiliary Winch**
Mounted behind front bumper, hydraulically driven with control in operator's console.
Pintle Hook:
28. **Pintle Hook, Rear**
29. **Pintle Hook, Front**
30. **Headlight and Taillight Grilles**
Welded steel protective grilles for headlights and taillights.
31. **Rearview Mirrors**
One mounted on right-hand deck stake and 1 mounted on left-hand deck stake.
32. **Lifting Rings**
Lifting rings at each corner of carry deck so sling can be attached for lifting crane.

OPERATOR COMPARTMENT OPTIONS:

33. **Operator Guard**
Tubular steel weldment with heavy expanded steel mesh top section.
34. **Operator Guard Cover**
Clear vinyl cover to go over Operator Guard, for inclement weather operations.
35. **Operator Guard Door**
Hinged door covers operator compartment side opening.
36. **All-Weather Cab**
Rigid-mounted canopy section and removable hinged door. Includes heater, electric windshield wiper, one sliding glass window in the door & one in the right side of canopy. Defroster fan included.
37. **Cab Heater**
Heater with two-speed fan for units without All Weather Cab.
38. **Windshield Washer**
Includes reservoir pump and nozzle.
39. **Floor Mat**
Vinyl mat with foam backing.
40. **Operator Suspension Seat**
Provides additional operator comfort.
41. **Noise Reduction Kit**
Includes floor mat, control valve and side panels of foam backed vinyl for noise reduction.

ELECTRICAL OPTIONS:

42. **Outrigger Warning System**
Two-tone alarm is activated when "outrigger down" controls are operated.
43. **Strobe Lights**
Yellow strobe light mounted on each side of turret weight box.

ELECTRICAL OPTIONS: Cont'd

44. **Lighted Instrument Gauges**
Instrument gauges equipped with lights for night operations.
45. **Amber Rotating Beacons**
Amber rotating beacon mounted on each side of turret weight box.
46. **Boom Work Lights**
One work light mounted to boom to light boom tip and one work light mounted to turret to light ground under boom tip.
47. **Boom Work Lights and Beacons**
Boom work lights and amber rotating beacons installed.
48. **Boom Work Lights and Strobe**
Boom work lights and strobe lights installed.
49. **Dome Light**
Interior light installed for units equipped with an All Weather Cab.
50. **Work Lights - Rear**
Two rectangular work lights in the rear panel of the chassis.

HYDRAULIC OPTIONS:

51. **Boom Structural Protection System**
Important to understand fully the description of the Boom Structural Protection System described in the IC-80 Engineering Spec. This option is not intended to and will not replace an LMI.

BOOM ATTACHMENTS:

53. **Boom Extension, 10 Foot**
Boom stowable.
54. **Boom Extension, 10 Foot, Offsettable**
Same as item 53, except the boom extension is offsettable to 3 different positions; 0 degree (inline), 15 degree and 30 degree offset.
Searcher Hook:
55. **Link Under Boom**
56. **Nose Mount**
57. **Load Moment Indicator-Krueger or PAT**
Warns operator of impending overload with audible and visual signals. Prevents overload by stopping boom functions that cause overloads. Readouts for load, boom angle, boom length, and load radius.
58. **Load Indicator - Krueger or PAT**
Includes 3-sheave load sensor on top of boom and readout box on top of instrument panel.

Should you, as an end user, require an option or special equipment on your IC-80-E that is not listed on our sales literature, please contact your dealer salesperson or the factory to receive a special quoted price.



GENERAL:

	Standard	Optional	
	<u>Drive Axle</u>	<u>Drive Steer Axle</u>	
Weight:			
IC-80-1E	14,600 lbs.	14,800 lbs.	
IC-80-2E	14,800 lbs.	15,000 lbs.	
IC-80-3E	15,100 lbs.	15,300 lbs.	
Gradeability:	71%	71%	
Turning Radius: (C/L of Outside Steering Wheel)	15' 0"	10' 6"	
Aisle Width for 90° Turn:	11' 0"	9' 9"	
Boom Movement:	<u>IC-80-1E</u>	<u>IC-80-2E</u>	<u>IC-80-3E</u>
Rotation	Continuous	Continuous	Continuous
Elevation	0° to 70°	0° to 70°	0° to 70°
Extension	12'	14' 6"	18' 6"
Boom Speeds:			
Rotation	1.7 RPM	1.7 RPM	1.7 RPM
Elevation	10.0 sec.	10.0 sec.	10.0 sec.
Extension	28.0 sec.	34.0 sec.	43.0 sec.

ENGINE:	Standard	Optional	Optional	Optional
Make	Continental	Cummins	Perkins	John Deere
Model	TM27	4B3.9	D4.236	4.239
Type	Gas	Diesel	Diesel	Diesel
No. Cyl.	4	4	4	4
Displacement	165 CID	239 CID	236 CID	239 CID
HP @ Gov.				
Speed	64	80	80	76
Fuel Tank Capacity:	20 Gallons			

TRANSMISSION:

Make: Borg Warner
Model: 72T/T18
Type: Reversing gearbox and manual shift 4-speed gearbox.
Equipped with torque convertor and transmission oil cooler. Torque convertor has stall ratio of 2.15:1.

<u>Gear Ratio:</u>	<u>Forward</u>	<u>Reverse</u>
First	6.324:1	6.956:1
Second	3.092:1	3.401:1
Third	1.686:1	1.855:1
Fourth	1.000:1	1.000:1

AXLES:

<u>Drive Axle:</u>	<u>Standard</u>	<u>Optional</u>
Make	Hurth	Hurth
Model	172	272A
Gear Ratio	11.98:1	11.98:1
Location	Front	Front
<u>Gear</u>	<u>Travel Speed</u>	<u>Drawbar Pull*</u>
First	3 MPH	11,900**
Second	7 MPH	5,820**
Third	12 MPH	3,170
Fourth	21 MPH	1,880

*Drawbar pull is calculated, based on Continental TM27 engine.
**Wheels will spin before these values are reached.

Steering Axle: (Non-Driving)

Make	Rockwell
Model	FF-931
Location	Rear

STEERING:

Standard:
Full hydraulic orbitrol unit with two double-acting hydraulic cylinders attached to rear axle.

Optional:
Full hydraulic orbitrol unit with two double-acting hydraulic cylinders attached to both front and rear axles. Steering modes include: Rear wheel steer & round steer.

BRAKES:

Service:

Front	Internal wet disc brakes
Rear	Drum type brakes
Parking	Band type mounted on transmission

TIRES:

Standard 10.00 x 15, 14-Ply, Highway Tread
Optional Grizzley Supersoft XS250 x 15 Solid Rubber
Optional Foam filling of the above pneumatic tires

CHASSIS:

CARGO DECK:

62 square feet of deck area*. 14,000 lbs. capacity on deck when load is centered over or between axles**. A storage box is located in front carry deck. Steps located on front corners.
*52 square feet with Cummins or John Deere engine
**14,000 pounds allowed at creep speed of 200 feet in 30 minutes

OUTRIGGERS:

Four hydraulic outriggers of box beam construction with direct-connected holding valves. Independent controls for left and right-hand outriggers. Outrigger pad dimension 9" x 12".

ACCESSORY STORAGE BOX:

Storage box is 14" deep x 10-1/2" long x 27" wide, located in front carry deck.

ELECTRICAL:

12 Volt System

Lighting Package:

One pair headlights with Hi and Low beams, back-up lights, integral tail, brake and turn signals and front turn signals.

Instrument Package:

Fuel, ammeter, oil pressure, water temperature, convertor oil temperature gauges and hourmeter.

Back-Up Alarm:

Provides pulsating sound when transmission is in reverse.

HYDRAULIC SYSTEM:

Tandem pump, direct-driven by engine crankshaft, rated at 16 and 32.5 GPM at rated RPM. Hydraulic oil tank capacity of 16 gallons.

BOOM ASSEMBLY:

Three-section boom assembly equipped with bearing pads, double acting hydraulic cylinders with direct-connected holding valves and boom angle indicator on each side of boom.

Boom Rotation:

Heavy-duty ball bearing rotation gear with external teeth. Rotation is powered by hydraulic motor and worm gear drive.

Boom Hoist:

Turret mounted planetary gear hoist hydraulically powered with a bare drum line pull of 10,000 lbs. at a line speed of 110 FPM. Includes downhaul weight, swivel hook and sheave block for 2-part line and 125 ft. of 9/16" hoist rope.

Anti-Two Block Device:

Prevents damage to hoist rope and/or crane components from pulling load hook against tip.



2-WHEEL DRIVE

- * Capacity on outriggers...18,000 lbs.
- * Pick and carry capacity up to...11,700 lbs.
- * Height...7' 3"
- * Width...6' 6"
- * Sheave height...up to 46'
- * Horizontal Reach...up to 40'
- * Tight turning radius
- * 2-Wheel drive standard
- * 4-Wheel steer optional
- * 4-Wheel drive optional
- * Powershift transmission
- * Fully hydraulic controls for smooth precise operations
- * Independent outrigger controls

DMC BRODERSON
Manufacturing Corp.

P.O. Box 14770, Lenexa, KS 66285-4770
14741 West 108th St. • Lenexa, KS 66215-2015
(913) 888-0806 • FAX (913) 888-8431
Website: broderickcranes.com

Tech Spec

4-Wheel Drive 4-Wheel Steer

- * Capacity on outriggers...18,000 lbs.
- * Pick and carry capacity up to...11,700 lbs.
- * Height...7' 3"
- * Width...6' 6"
- * Sheave height...up to 46'
- * Horizontal Reach...up to 40'
- * Tight turning radius...11' 8"
- * 4-Speed synchromesh transmission
- * Independent outrigger controls
- * 4-Wheel hydraulic internal wet disc brakes
- * Independent outrigger controls



IC-80-1F

IC-80-1F 8'-2" - 20'-2" BOOM

CAPACITIES APPLY TO OPERATION ON FIRM LEVEL SURFACE					
LOAD RADIUS FEET	MAIN BOOM OR EXTENSION CAPACITIES IN POUNDS				
	360° ROTATION		OVER FRONT		
	ON RUBBER	ON OUTRIGGERS	ON RUBBER	ON OUTRIGGERS	
5	9600	17000	11700	18000	
6	7900	14500	10400	14500	
8	5750	10250	8400	10250	
10	4150	7700	6300	7700	
12	3100	6550	4650	6550	
14	2425	5550	3650	5550	
16	1975	4650	3000	4650	
18	1625	3950	2500	4150	
20	1400	3550	2150	3800	
10' BOOM EXT. EXTENSION	10-FOOT BOOM EXTENSION - STRAIGHT OR OFFSET				
	MAIN BOOM ANGLE				
	ANGLE	0°	30°	45°	60°
	* † 0°	2250	2600	3200	5000
	† 15°	—	2400	2700	3500
	† 30°	—	2250	2500	3000

* USE 0° FOR STRAIGHT BOOM EXTENSION.
 † USE 0°, 15° OR 30° FOR OFFSET BOOM EXTENSION.
 BOOM EXTENSION LOADS MUST NOT EXCEED MAIN BOOM CAPACITY.

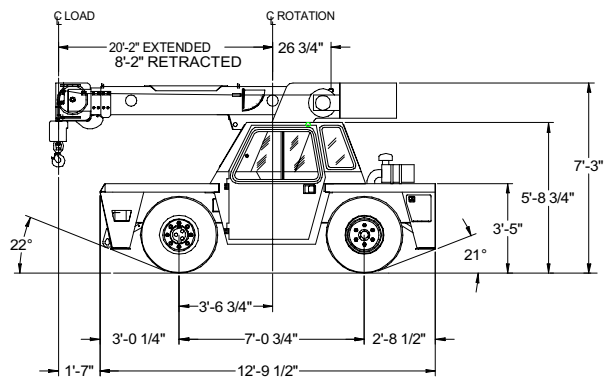
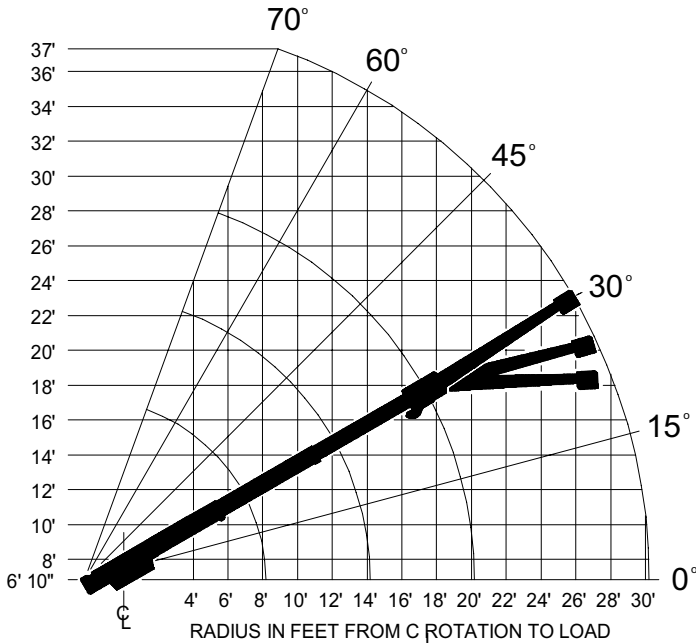
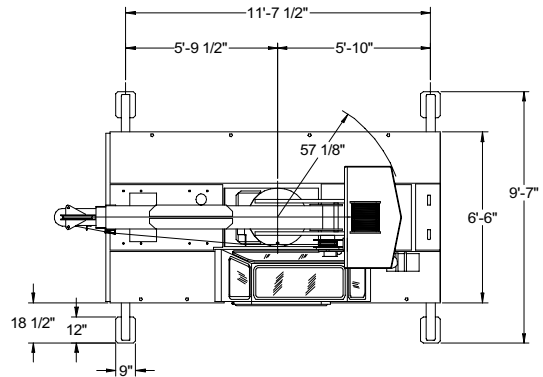
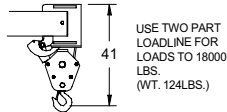
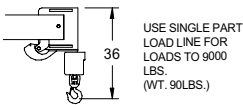
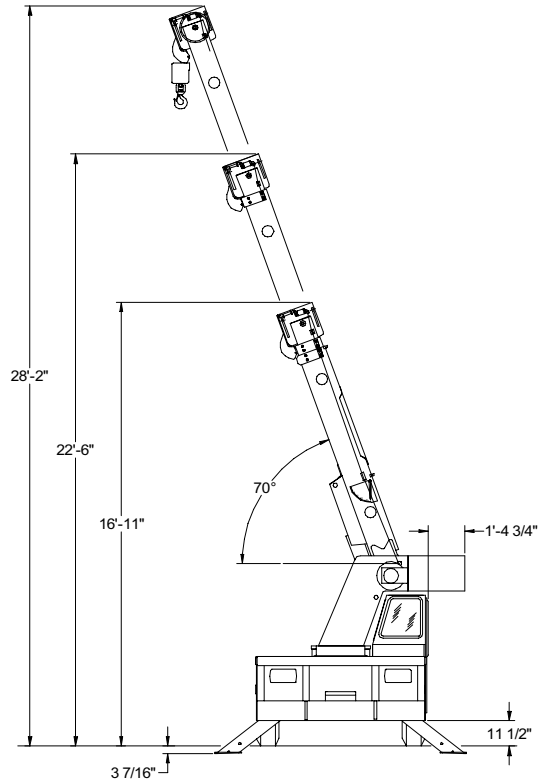

IC-80-2F

IC-80-2F 9'-6" - 24'-0" BOOM

CAPACITIES APPLY TO OPERATION ON FIRM LEVEL SURFACE					
LOAD RADIUS FEET	MAIN BOOM OR EXTENSION CAPACITIES IN POUNDS				
	360° ROTATION		OVER FRONT		
	ON RUBBER	ON OUTRIGGERS	ON RUBBER	ON OUTRIGGERS	
5	9500	17000	11600	18000	
6	7800	14500	10200	14500	
8	5500	10250	8250	10250	
10	3900	7700	6200	7700	
12	2900	6550	4550	6550	
14	2300	5550	3550	5550	
16	1850	4550	2850	4550	
18	1550	3950	2400	4050	
20	1300	3250	2050	3650	
22	1100	2875	1750	3300	
24	925	2475	1550	3100	
26	850	2250	1350	2750	
28	700	2000	1175	2500	
30	600	1775	1025	2300	
32	500	1625	900	2100	
34	425	1400	800	1950	
10-FOOT BOOM EXTENSION - STRAIGHT OR OFFSET					
MAIN BOOM ANGLE					
ANGLE	0°	30°	45°	60°	70°
* 1 0°	2250	2600	3200	5000	7000
† 1 15°	—	2400	2700	3500	4200
† 1 30°	—	2250	2500	3000	3300

* USE 0° FOR STRAIGHT BOOM EXTENSION.
 † USE 0°, 15° OR 30° FOR OFFSET BOOM EXTENSION.
 BOOM EXTENSION LOADS MUST NOT EXCEED MAIN BOOM CAPACITY.

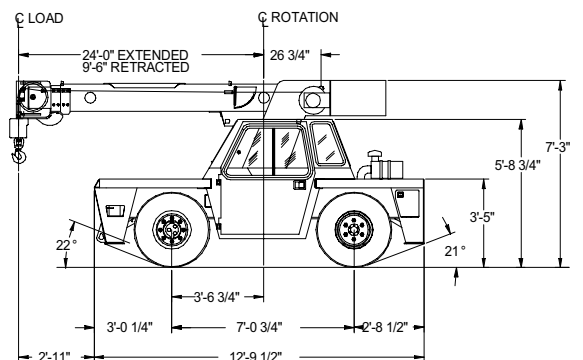
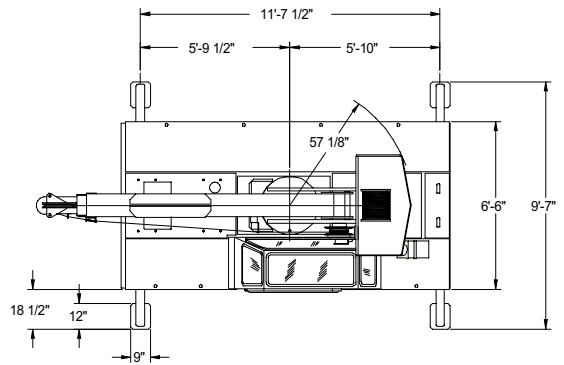
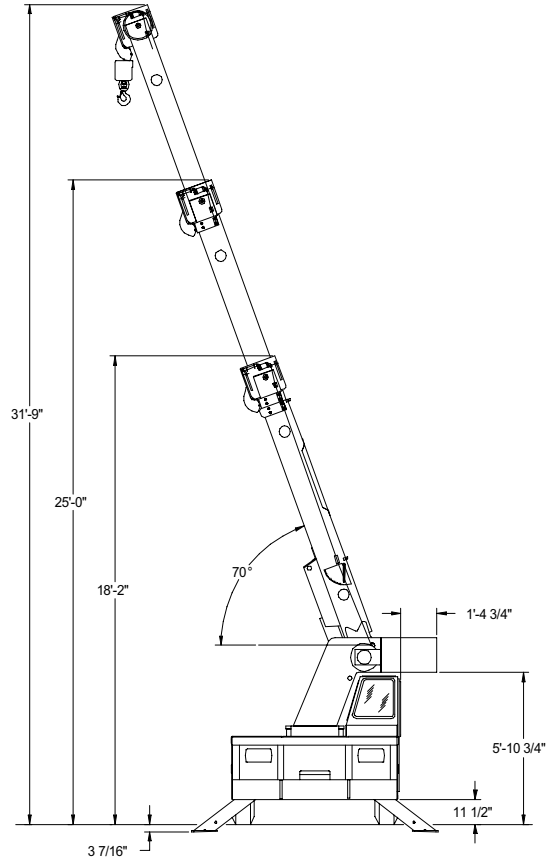
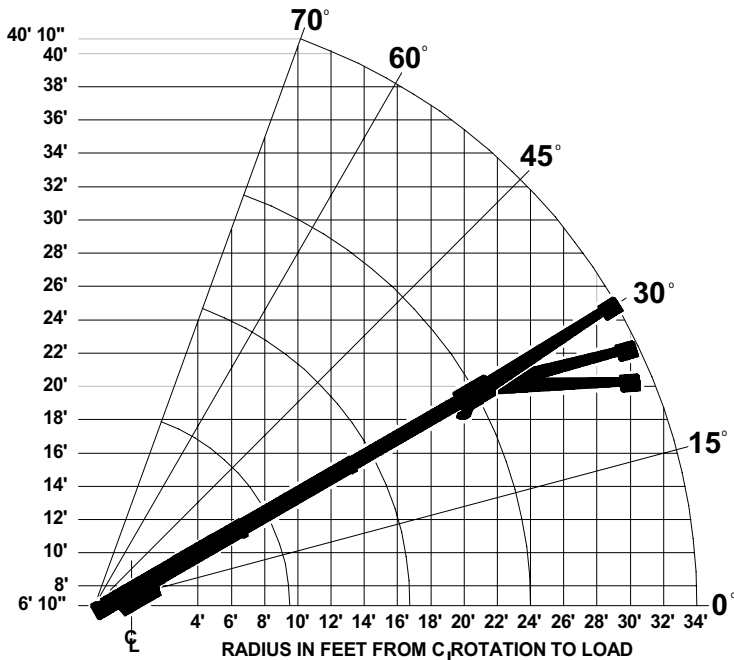
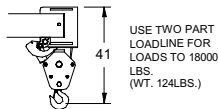
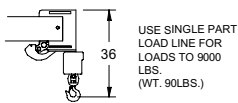

IC-80-3F

IC-80-3F 11'-6" - 30'-0" BOOM

CAPACITIES APPLY TO OPERATION ON FIRM LEVEL SURFACE						
LOAD RADIUS FEET	MAIN BOOM OR EXTENSION CAPACITIES IN POUNDS					
	360° ROTATION		OVER FRONT			
	ON RUBBER	ON OUTRIGGERS	ON RUBBER	ON OUTRIGGERS		
MAIN BOOM	5	9400	17000	11400	18000	
	6	7550	14000	10000	14000	
	8	5250	10000	8100	10000	
	10	3600	7700	6100	7700	
	12	2650	6100	4450	6100	
	14	2050	5200	3400	5200	
	16	1600	4400	2700	4400	
	18	1250	3650	2200	3900	
	20	1050	3050	1800	3400	
	22	850	2650	1550	3050	
	24	750	2300	1350	2800	
	26	650	2050	1150	2550	
	28	550	1850	1000	2350	
	30	450	1650	900	2150	
	10' BOOM EXT.	32	350	1550	750	1950
		34	250	1400	650	1800
36		200	1250	550	1650	
38		150	1100	450	1500	
40		100	1000	400	1400	
10-FOOT BOOM EXTENSION - STRAIGHT OR OFFSET						
MAIN BOOM ANGLE						
ANGLE		0°	30°	45°	60°	70°
* † 0°	2250	2600	3200	5000	7000	
† 15°	--	2400	2700	3500	4200	
† 30°	--	2250	2500	3000	3300	

* USE 0° FOR STRAIGHT BOOM EXTENSION.
 † USE 0°, 15° OR 30° FOR OFFSET BOOM EXTENSION.
 BOOM EXTENSION LOADS MUST NOT EXCEED MAIN BOOM CAPACITY.

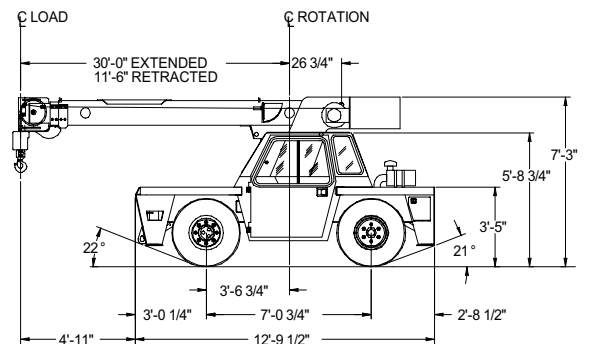
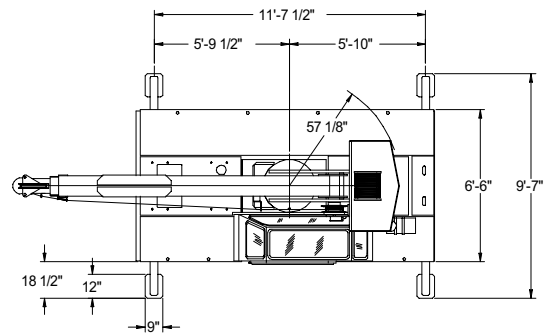
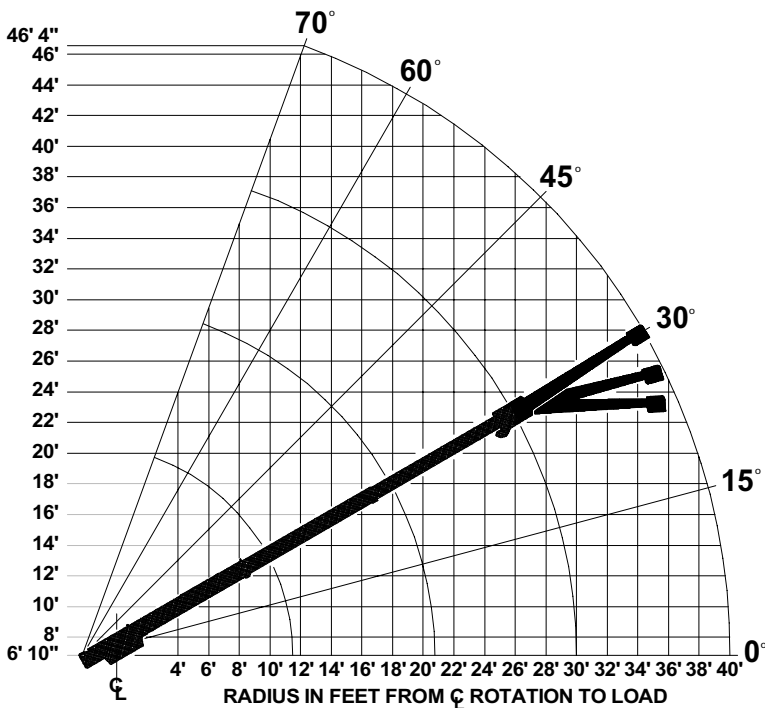
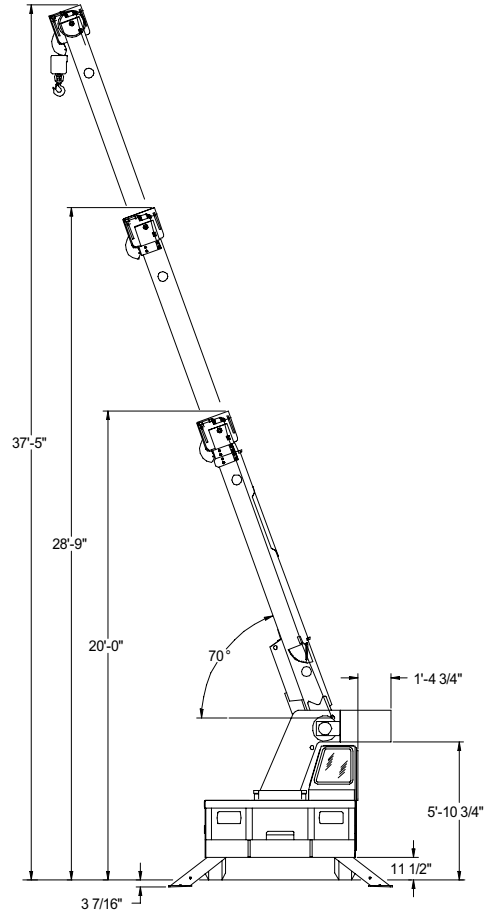
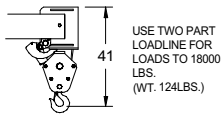
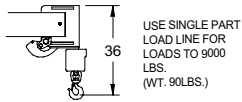

IC-80-F

GENERAL:

Weight:	IC-80-1F	IC-80-2F	IC-80-3F
2-Wheel Steer	15,400 lbs.	15,600 lbs.	15,900 lbs.
4-Wheel Steer	15,600 lbs.	15,800 lbs.	16,100 lbs.
4-Wheel Drive	16,400 lbs.	16,600 lbs.	16,900 lbs.

Boom Movement:

Rotation	Continuous	Continuous	Continuous
Elevation	0° to 70°	0° to 70°	0° to 70°
Extension	12 ft.	14 ft. 6 in.	18 ft. 6 in.

Boom Speeds:

Rotation	2.0 RPM	2.0 RPM	2.0 RPM
Elevation	10.0 sec.	10.0 sec.	10.0 sec.
Extension	17.0 sec.	21.0 sec.	27.0 sec.

Turning Radius:	Standard	Optional	Optional
(C/L of Outside Steering Wheel)	2-Wheel Steer	4-Wheel Steer	4-Wheel Drive
	15 ft. 4 in.	10 ft. 9 in.	11 ft. 8 in.

Aisle Width for 90° Turn:			
	11 ft. 0 in.	9 ft. 7 in.	9 ft. 9 in.

ENGINE:	Standard	Optional
Make	Continental	Cummins
Model	TM27	4B3.9
Type	Gas	Diesel
No. Cyl.	4	4
Displacement	165 CID	239 CID
HP @ Gov. Speed	66	80
Fuel Tank Capacity:	20 Gallons	

TRANSMISSION:

2-Wheel Drive:

Powershift transmission with 4-speeds in forward and reverse. Provides powershifts at any engine speed in any gear. All shifting is done with a single lever electrical control mounted on the steering column. Multiple-disc clutch packs operated by solenoid valve provide forward, neutral, reverse & speed selection. Equipped with oil cooler and filter. Torque converter has stall ratio of 2.2:1.

Gradeability 70 percent.

	Forward/Reverse	Travel	Drawbar
Gear	Gear Ratios	Speed	Pull
First	5.72:1	4 MPH	10,900 lbs.
Second	3.23:1	7 MPH	6,090 lbs.
Third	1.77:1	12 MPH	3,270 lbs.
Fourth	1.00:1	22 MPH	1,780 lbs.

TRANSMISSION: (Cont'd)

4-Wheel Drive:

Remote mounted synchromesh 4-speed. Forward, neutral and reverse control mounted on steering column. 4-speed control has side lever & push button knob for electric declutching. Can be shifted while in motion. Equipped with oil cooler and filter. Torque converter has stall ratio of 2.2:1.

Gradeability 72 percent.

	Forward/Reverse	Travel	Drawbar
Gear	Gear Ratios	Speed	Pull
First	4.29:1	5 MPH	11,500 lbs.
Second	2.66:1	8 MPH	7,070 lbs.
Third	1.41:1	15 MPH	3,670 lbs.
Fourth	0.77:1	27 MPH	1,930 lbs.

AXLES:

Front:

2-Wheel Steer:

Planetary drive axle with 11.98:1 ratio. Differential is "Limited Slip." Axle mounted rigidly to frame.

4-Wheel Steer:

Planetary drive/steer axle with 11.98:1 ratio. Differential is "Limited Slip." Axle mounted rigidly to frame.

Rear:

2-Wheel Drive:

Axle with 1-1/2 degree oscillation in either direction.

4-Wheel Drive:

Planetary drive/steer axle with 11.98:1 ratio. Differential is "Limited Slip." 1-1/2 degree oscillation in either direction.

STEERING:

2-Wheel Steer:

Hydraulic steering unit with two cylinders attached to rear axle.

4-Wheel Steer:

Hydraulic steering unit with two cylinders attached to each axle. Rear axle is the primary steer. An electric switch in the operator's compartment is used to select rear-wheel steering or four-wheel round steering.

BRAKES:	2-Wheel Drive	4-Wheel Drive
Front	Internal wet disc brakes	Internal wet disc brakes
Rear	Drum type	Internal wet disc brakes
Parking	Disc type	Disc type

TIRES:

2-Wheel Drive	10.00 x 15, load range J radial, highway type tread.
4-Wheel Drive	10.00 X 15, mining & industrial, 16 ply rating.

CHASSIS:

Cargo Deck:

64 square feet of deck area.* 14,000 lbs. capacity on deck when load is centered over or between axles.** A storage box is located in front cargo deck. Steps located on front corners.

* 54 Square feet with Cummins engine.

**14,000 pounds allowed at creep speed of 200 feet in 30 minutes.

Fire Extinguisher:

1A:10B:C, 2-1/2 pound dry chemical. Mounted on dashboard.

Outriggers:

Four hydraulic outriggers of box beam construction with direct-connected holding valves. Independent controls for each outrigger. Each cylinder equipped with direct-connected holding valves. Outrigger pad dimension 9" x 12".

Accessory Storage Box:

Storage box located in front cargo deck.

OPERATOR COMPARTMENT:

Operator's control station provides one-position access to all operating functions. Includes adjustable operator's seat & retracting seat belt.

ELECTRICAL:

12 Volt System

Instrument Package:

Fuel, ammeter, oil pressure, water temperature, transmission oil temperature gauges & hourmeter. Also included are warning lights for low transmission pressure, turn signal, high beams, hazard lights, parking brake & 4-wheel drive.

ELECTRICAL: (Cont'd)

Lighting Package:

One pair headlights with Hi and Low beams, back-up lights, integral tail, brake, front and rear turn signals & emergency flasher switch at operator's station. 12V horn actuated by button on shifting control.

Back-Up Alarm:

Provides pulsating sound from 97 dB alarm when transmission is in reverse. Conforms to SAE J994b.

HYDRAULIC SYSTEM:

Tandem pump, direct-driven by engine crankshaft, rated at 17 & 32 GPM at rated RPM. Hydraulic oil tank capacity of 22 gallons.

BOOM ASSEMBLY:

Three-section boom assembly equipped with bearing pads, double-acting hydraulic cylinders with direct-connected holding valves & boom angle indicator on each side of boom.

Boom Rotation:

Heavy-duty ball bearing rotation gear with external teeth. Rotation is powered by hydraulic motor and worm gear drive.

Boom Hoist:

Turret mounted planetary gear hoist hydraulically powered with a bare drum line pull of 10,000 lbs. at a line speed of 110 FPM. Includes downhaul weight, swivel hook & sheave block for 2-part line and 125 ft. of 9/16" hoist rope.

Anti-Two-Block Device:

Prevents damage to hoist rope and/or crane components from pulling load hook against tip.

IC-80-F

Listed below are brief descriptions of each option available for the IC-80-F Industrial Cranes. Consult the IC-80-F Engineering Spec for additional information on each option.

MODELS:

- IC-80-1F** Industrial Crane with 8'2"-20'2" Boom
- IC-80-2F** Industrial Crane with 9'6"-24' Boom
- IC-80-3F** Industrial Crane with 11'6"-30' Boom

ENGINE:

LP Gas Fuel System

Contains all necessary components for LP gas operations.

Dual Fuel System

Contains all necessary components to burn LP gas and gasoline.

GM 3.0 L EFI Gasoline Engine

with dual fuel

Diesel Engine

Cummins - 4B3.9

Spark Arrester Muffler

Installed in addition to std. muffler.

Catalytic Converter

Reduces engine emissions.

Engine Heater

Engine coolant heater installed to circulate warm water through engine. Plugs into 120 volt AC.

Ether Injection System

Ether starting aid controlled by switch in operator compartment and injects ether directly into intake manifold.

Engine Shut Down Gauges

Shuts engine off when high water temperature or low engine oil pressure occurs.

AXLE & STEERING OPTIONS:

- 2-Wheel Steer & 2-Wheel Drive**
- 4-Wheel Steer & 2-Wheel Drive**
- 4-Wheel Steer & 4-Wheel Drive**

TIRE OPTIONS:

Solid Rubber Tires:

8.25 x 15

8.25 x 15 Non-Marking

Mining & Industrial Tires

10.00 x 15 , 16-Ply Rating

Foam Filling of Tires

Spare Tire & Wheel

Highway Tread, 10.00 x 15

Mining & Industrial, 10.00 x 15

CHASSIS OPTIONS:

Auxiliary Winch

Mounted behind front bumper, hydraulically driven with control in operator's console.

CHASSIS OPTIONS: (Cont'd)

Auxiliary Winch Plumbing

Quick-connect fittings at front of chassis for front auxiliary winch previously listed.

Pintle Hook:

Pintle Hook, Rear

Pintle Hook, Front

Headlight and Taillight Grilles

Welded steel protective grilles for headlights and taillights.

Rear Work Light Grilles

Protective grilles for worklights.

Rearview Mirrors

One mounted on right-hand deck stake & one mounted on left-hand deck stake.

Lifting Rings

Lifting rings at each corner of cargo deck so sling can be attached for lifting crane.

OPERATOR COMPARTMENT OPTIONS:

Operator Guard

Tubular steel weldment with heavy expanded steel mesh top section.

Operator Guard Cover

Clear vinyl cover which goes over Operator Guard, for inclement weather operations.

Operator Guard Door

Hinged door covers operator compartment side opening.

All-Weather Cab

Rigid-mounted canopy section & removable hinged door. Includes heater, electric windshield wiper, one sliding glass window in the door & one in the right side of canopy. Defroster fan & dome light included.

Cab Heater

Heater with two-speed fan for units without All Weather Cab.

Windshield Washer

Includes reservoir pump and nozzle.

Floor Mat

Vinyl mat with foam backing.

Operator Suspension Seat

Provides additional operator comfort.

Noise Reduction Kit

Includes floor mat, control valve and side panels of foam backed vinyl for noise reduction.

Air Conditioning

Air Conditioner with R134 coolant.

ELECTRICAL OPTIONS:

Outrigger Alarm System

Two-tone alarm is activated when "outrigger down" controls are operated.

CHASSIS OPTIONS: (Cont'd)

Strobe Lights

Yellow strobe light mounted on each side of turret weight box.

Amber Rotating Beacons

Amber rotating beacon mounted on each side of turret weight box.

Boom Work Lights

One work light mounted to boom to light boom tip and one work light mounted to turret to light ground under boom tip.

Boom Work Lights and Beacons

Boom work lights and amber rotating beacons installed.

Boom Work Lights and Strobes

Boom work lights and strobe lights installed.

Work Lights

Two work lights recessed in rear bumper.

Boom Structural Protection System:

Important to understand fully the description of the Boom Structural Protection System described in the IC-80 Engineering Spec. This option is not intended to and will not replace an LMI.

BOOM ATTACHMENTS:

Boom Extension, 10 Foot

Boom stowable.

Boom Extension, 10 Foot, Offsettable

Same as above item, except the boom extension is offsettable to 3 different positions; 0 degrees (inline), 15 degrees and 30 degrees offset.

Searcher Hook: (Two Types)

Link Under Tip

Nose Mount

Load Moment Indicator

Warns operator of impending overload with audible and visual signals. Prevents overload by stopping boom functions that cause overloads.

Load Indicator

Includes 3-sheave load sensor on top of boom and readout box on top of instrument panel.

Should you, as an end user, require an option or special equipment on your IC-80-F that is not listed on our sales literature, please contact your dealer salesperson or the factory to receive a special quoted price.