

44 t
TCG45



SPECIFICHE TECNICHE
PRESTAZIONI DELLA GRU

Portata a 2.5 m da asse ralla	44 t
Lunghezza braccio (chiuso / aperto)	9.5 / 37.4 m
Altezza testa braccio	39.0 m

La macchina può sollevare carichi in condizioni statiche o in movimento fino a una inclinazione di 4° in direzione longitudinale e/o trasversale secondo apposite tabelle di carico

PRESTAZIONI DEL CARRO

Velocità massima di traslazione	2.5 km/h
---------------------------------	----------

MASSE ⁽¹⁾

Cingolo destro	Cingolo sinistro	Totale
19.4 t	19.4 t	38.8 t

(1) Gru in versione standard: senza argano ausiliario, senza prolunghe.

VELOCITÀ / TEMPI DI LAVORO ⁽²⁾

Argano principale (massima in tiro diretto al primo strato)	67 m/min
Argano ausiliario (massima in tiro diretto al primo strato)	80 m/min
Sollevamento / Discesa braccio telescopico	83/83 s
Sfilo / Rientro braccio telescopico (da 9.5 m a 37.4 m)	200/212 s
Rotazione sovrastruttura	30 s

(2) Valori medi di riferimento misurati a 2000 giri/min motore e forniti a puro titolo indicativo

SOTTOCARRO

Telaio	Struttura saldata a cassone. Cingoli allargabili idraulicamente.
Motore	CUMMINS QSB6.7: 6 cilindri in linea - Cilindrata 6.70 dm ³ - Raffreddato ad acqua con intercooler - Turbocompresso - Common rail Potenza massima 164 kW a 2200 giri/min - Coppia massima 945 Nm a 1500 giri/min. Certificazione 2004/26/CE Fase IIIA.
Serbatoio	300 l.
Trasmissioni	Idrostatica in circuito chiuso su ciascun cingolo mediante un riduttore ruota indipendente azionato da motore idraulico a doppia cilindrata.
Cingoli	In acciaio con pattini sagomati. Larghezza 700 mm.

SOVRASTRUTTURA

Braccio	n. 5 elementi.
Sollevarmento	n. 1 martinetto idraulico a doppio effetto. Possibilità di inclinazione del braccio da -2° a $+78^{\circ}$.
Sfilo	L'elemento 2 è sfilato in modo indipendente rispetto ai rimanenti, gli elementi 3, 4 e 5 sono sfilati in modo proporzionale e continuo. Cilindro di sfilo a due corse indipendenti con sistema di rinvio a catene e funi. Possibilità di sfilo sotto carico parziale.
Argano	Azionato da motore idraulico a pistoni assiali a cilindrata fissa con riduttore epicicloidale. Freno negativo ad inserimento automatico. Dispositivo pressafune. Doppia velocità di rotazione. Fune diametro 16 mm, lunghezza 185 m. (capacità massima di sollevamento 4500 daN). In opzione argano ausiliario (capacità massima di sollevamento 3800 daN), fune diametro 15 mm lunghezza 150 m.
Contrappeso	N°2 elementi smontabili (sinistro da 4700 kg / destro da 4500 kg).
Rotazione	Continua su 360° mediante motore idraulico e riduttore epicicloidale su ralla a doppio giro di sfere con dentatura interna. Freno negativo ad inserimento automatico. Comando di sblocco del freno per l'allineamento diretto del braccio sulla verticale del carico da sollevare.
Cabina	Ad ampia visibilità con sportello scorrevole. Dotata di riscaldamento. Vetro anteriore e superiore con tergicristallo. Vetro superiore e posteriore apribili. Seggiolino completamente regolabile su sospensioni anti-shock, dotato di braccioli sollevabili che integrano i manipolatori per il comando dei vari movimenti della gru.
Sicurezza	Valvole di massima pressione su ogni circuito idraulico. Valvola di bilanciamento e frenatura su gruppo rotazione. Valvola di bilanciamento e frenatura sull'argano. Interruttore di fine corsa su testa braccio per la salita del bozzello. Interruttore di fine corsa per conservare tre giri di avvolgimento fune sull'argano. Dispositivo limitatore di carico con indicazione: Inclinazione braccio Lunghezza braccio Carico sollevato Massimo carico sollevabile Possibilità di impostare la limitazione dei movimenti del braccio telescopico.

IMPIANTI

Idraulico	Alimentazione: n. 1 pompa tripla ad ingranaggi e n. 2 pompe a pistoni a cilindrata variabile. Controllo movimenti: distributori azionati da manipolatori idraulici con possibilità di manovre simultanee proporzionali. Controllo cingoli: distributori azionati da pedipolatori dotati di leve. Filtraggio: n. 2 filtri a cartuccia sul circuito di ritorno e n. 2 filtri sul circuito di aspirazione delle pompe a pistoni.
Elettrico	a 24 V con alternatore da 70 A e n. 2 batterie da 132 Ah.

OPZIONALI PRINCIPALI

Prolunga da 8 m. Angolazioni: 0° , 20° , 40°
Impianto condizionatore caldo/freddo in cabina guida
Kit per operare fino a -20°C
Kit per operare fino a $+45^{\circ}\text{C}$
Argano ausiliario
Bozzello da 10 T
Gancio da 5 T

Riferirsi al dealer di zona per un elenco completo degli opzionali.

SPECIFICATIONS
CRANE PERFORMANCE DATA

Capacity at 2.5 m from slewing axis	44 t
Boom length (retracted / extended)	9.5 / 37.4 m
Boom head height	39.0 m

The machine can lift static or moving loads up to 4° slant -lengthwise and/or crosswise- as specified in the relevant lifting capacity charts

TRUCK PERFORMANCE DATA

Max. travelling speed	2.5 km/h
-----------------------	----------

WEIGHTS ⁽¹⁾

Right track	Left track	Total
19.4 t	19.4 t	38.8 t

(1) Standard crane: no auxiliary winch and no extensions.

OPERATING SPEED / TIMES ⁽²⁾

Main winch (max. speed under direct pull at first layer)	67 m/min
Auxiliary winch (max. speed under direct pull at first layer)	80 m/min
Telescopic boom lifting / lowering	83/83 s
Telescopic boom extension / retraction (9.5 m to 37.4 m)	200/212 s
Upper structure slewing	30 s

(2) Average reference indicative values measured at 2000 rpm of engine

UNDERTRUCK

Frame	Welded body. Hydraulic widening tracks.
Engine	CUMMINS QSB6.7: no. 6 in-line cylinders - displacement: 6.70 cu dm - water cooling with intercooler - turbo supercharger - Common rail Max. power 164 kW at 2200 rpm - Max. torque 945 Nm at 1500 rpm. 2004/26/CE Step IIIA approved.
Tank	300 l.
Transmission	Hydrostatic loop transmission on each track through a separate gearbox controlled by double displacement hydraulic motor.
Tracks	Steel tracks featuring profiled runners. 700 mm wide.

UPPER STRUCTURE

Boom	no. 5 elements.
Lifting	no. 1 double action hydraulic jack. Boom inclination: -2° to $+78^{\circ}$.
Extension	Element 2 slides out regardless of the other parts; elements 3, 4 and 5 slide out in a proportional and continuous way. Extension cylinder with two independent strokes, chain and rope drive system. Extension under partial load possible.
Winch	Controlled by fixed displacement hydraulic motor equipped with axial pistons and planetary gearbox. Automatic negative brake for winch. Cable tensioner. Two different rotation speeds. Rope diameter 16 mm, length 185 m. (max. lifting capacity 4500 daN). On request, auxiliary winch (max. lifting capacity 3800 daN), rope diameter 15 mm length 150 m.
Conterweight	No. 2 elements (left 4700 kg / right 4500 kg).
Rotation	360° non-stop rotation controlled by hydraulic motor equipped with planetary gearbox on slewing ring having double ball ring and inner toothing. Automatic negative brake. Brake release for direct alignment of boom along load vertical line.
Operating cab	Sliding door. Wide visibility. Equipped with heating system. Front and upper window with windscreen wiper. Upper and back windows can be opened. Fully adjustable seat onto shockproof suspensions. quipped with tiltable arm rests with integrated hand controls for crane operation.
Safety	Max. pressure valves for each hydraulic circuit. Balancing braking valve for the slewing unit. Balancing braking valve for the winch. Limit switch onto boom head for hoisting block lift. Limit switch for having three winding turns around the winch. Load limiting device with indicator for: <ul style="list-style-type: none"> Boom inclination Boom length Load weight Max. load which can be lifted Telescopic boom movement limit can be set.

SYSTEMS

Hydraulic system	Feeding: no. 1 triple gear pump and no. 2 variable displacement piston pumps. Movement control: distributors controlled by hydraulic manipulators. More proportional operations can be carried out at the same time. Track control: distributors controlled by foot controls. Filtering: no. 2 cartridge filters in return circuit and no. 2 filters in intake circuit of piston pumps.
Electric system	24 V, 70 A generator and no. 2 132 Ah batteries.

MAIN OPTIONS

Extension 8 m, offsettable at 0° , 20° , 40°
Air conditioning / heating system into operating cab
Operating kit for temperatures up to -20°C
Operating kit for temperatures up to $+45^{\circ}\text{C}$
Auxiliary winch
10 t hook block
5 t hook

Refer to your local dealer for a complete list of available options.

CARACTÉRISTIQUES

PERFORMANCES DE LA GRUE

Capacité à 2.5 m depuis l'axe d'orientation	44 t
Longueur de la flèche (fermée / ouverte)	9.5 / 37.4 m
Hauteur tête flèche	39.0 m

The machine can lift static or moving loads up to 4° slant -lengthwise and/or crosswise- as specified in the relevant lifting capacity charts

PERFORMANCES DU CHASSIS

Vitesse maximum de translation	2.5 km/h
--------------------------------	----------

MASSES ⁽¹⁾

Chenille droite	Chenille gauche	Total
19.4 t	19.4 t	38.8 t

(1) Grue en version standard : sans treuil auxiliaire, sans extension.

OPERATING SPEED / TIMES ⁽²⁾

Treuil principal (maximum en tirage direct première couche)	67 m/min
Treuil auxiliaire (maximum en tirage direct première couche)	80 m/min
Relevage / Descente flèche télescopique	83/83 s
Télescopage flèche (de 9.5 m à 37.4 m)	200/212 s
Orientation partie tournante	30 s

(2) Valeurs moyennes de référence mesurées à 2000 tr/min moteur et fournies à titre purement indicatif

CHÂSSIS

Structure	Structure soudée à caisson. Chenilles avec possibilité d'élargissement hydrauliquement.
Moteur	CUMMINS QSB6.7: 6 cylindres en ligne - Cylindrée 6.70 dm ³ - Refroidi à eau avec intercooler - Turbocompressé - Common rail Puissance maximum 164 kW à 2200 tours/min - Couple maximum 945 Nm à 1500 min. Certification 2004/26/CE Phase IIIA.
Réservoir	300 l.
Transmission	Hydrostatique en circuit fermé sur chaque chenille au moyen d'un réducteur de roue indépendant actionné par un moteur hydraulique à double cylindrée.
Chenilles	En acier avec patins façonnés. Largeur 700 mm.

PARTIE TOURNANTE

Flèche	n. 5 éléments.
Relevage	n. 1 vérin hydraulique à double effet. Possibilité d'incliner la flèche de -2° à $+78^{\circ}$.
Télescopage	L'élément 2 est télescopé de façon indépendante, les éléments 3, 4 et 5 sont télescopés de façon proportionnelle et continue. Vérin hydraulique à double effet et double extension avec système interne de renvoi à chaînes et câbles. Possibilité de télescopage sous charge partielle.
Treuil	Actionné par un moteur hydraulique à pistons axiaux à cylindrée fixe avec réducteur épicycloïdal. Frein négatif à enclenchement automatique. Dispositif serre-câble. Double vitesse de rotation. Câble diamètre 16 mm longueur 185 m. Capacité maximum de levage 4500 daN. En option treuil auxiliaire avec capacité maximum de levage 3800 daN. Câble diamètre 15 mm longueur 150 m.
Contrepoids	N°2 éléments démontables (gauche 4700 kg / droite 4500 kg).
Orientation	Continue sur 360° au moyen d'un moteur hydraulique et d'un réducteur épicycloïdal sur couronne d'orientation à double tour de billes avec denture interne. Frein négatif à enclenchement automatique. Commande de déblocage du frein pour l'alignement direct de la flèche à la verticale de la charge à lever.
Cabine	A large visibilité avec porte coulissante. Dotée de chauffage. Vitres avant et supérieure avec essuie-glaces. Vitres supérieure et arrière ouvrables. Siège entièrement réglable sur suspension antichoc, doté d'accoudoirs relevables comprenant les manipulateurs pour la commande des différents mouvements de la grue.
Sécurité	Soupapes de pression maximum sur chaque circuit hydraulique. Vanne d'équilibrage et de freinage sur le groupe d'orientation. Vanne d'équilibrage et de freinage sur le treuil. Interrupteur de fin de course sur tête flèche pour la montée de la moufle. Interrupteur de fin de course pour conserver trois tours d'enroulement câble sur le treuil. Limiteur de charge avec indication: Inclinaison flèche Longueur flèche Charge levée Charge maximale levable Possibilité de programmer la limitation des mouvements du bras télescopique.

CIRCUITS

Hydraulique	Alimentation: n. 1 pompe tripe à engrenage et n. 2 pompes à pistons à cylindrée variable. Contrôle des mouvements: distributeurs actionnés par des manipulateurs hydrauliques avec possibilité de manœuvres simultanées proportionnelles. Contrôle chenilles: distributeurs actionnés par des manipulateurs à pédalier. Filtrage: n. 2 filtres à cartouche sur le circuit de retour et n. 2 filtres sur le circuit d'aspiration des pompes à pistons.
Electrique	à 24 V avec alternateur de 70 A et n. 2 batteries de 132 Ah.

OPTIONS PRINCIPALES

Extension de 8 m. Angles : 0° , 20° , 40°
Groupe de climatisation chaud / froid dans la cabine de conduite
Kit pour intervenir jusqu'à -20°C
Kit pour intervenir jusqu'à $+45^{\circ}\text{C}$
Treuil auxiliaire
10 t moufle
Crochet 5 t

Se référer au concessionnaire local pour une liste complète des options.

TECHNISCHE DATEN

EIGENSCHAFTEN DES KRANS

Tragfähigkeit bei 2.5 m ab Drehplatte	44 t
Auslegerlänger (eingefahren/ausgefahren)	9.5 / 37.4 m
Auslegerkopfhöhe	39.0 m

Die Maschine kann den entsprechenden Lasttabellen gemäß sich in statischen Bedingungen oder sich in Bewegung befindliche Lasten bis auf eine Neigung von 4° längs und/oder quer heben.

EIGENSCHAFTEN DES WAGENS

Höchstgeschwindigkeit.	2.5 km/h
------------------------	----------

GEWICHT ⁽¹⁾

Raupen rechts	Raupen links	Gesamt
19.4 t	19.4 t	38.8 t

(1) Kran in Standardausführung und bei Betrieb: ohne Zusatzwinde und ohne Auslegerverlängerungen.

BETRIEBSGESCHWINDIGKEIT / -ZEITEN ⁽²⁾

Hauptwinde (Höchstgeschwindigkeit bei direktem Zug erste schicht)	67 m/min
Zusatzwinde (Höchstgeschwindigkeit bei direktem Zug erste schicht)	80 m/min
Heben / Senken des Teleskopauslegers	83/83 s
Ausfahren / Einfahren des Teleskopauslegers (von 9.5 m bis 37.4 m)	200/212 s
Schwenken des Oberwagens	30 s

(2) Durchschnittliche Bezugswerte, die bei einer Motordrehzahl von 2000/min gemessen wurden und die als reine Anhaltswerte angegeben werden

UNTERWAGEN

Rahmen	Verschweißter Kastenrahmen. Die Raupen werden hydraulisch angetrieben.
Motor	CUMMINS QSB6.7: Reihenmotor mit 6 Zylindern - Hubraum 6.70 dm ³ - mit Intercooler-Wasserkühlung - Turbokompressor - Common rail Höchstleistung 164 kW bei 2200 U/min - maximales Drehmoment 945 Nm bei 1500 U/min. Zertifizierung: 2004/26/EG Stufe IIIA.
Behälter	300 l.
Lenkung	Hydrostatische Lenkung im geschlossenen Kreislauf auf jeder Raupe über ein unabhängiges Radumsetzungsgetriebe mit Hydraulikmotorantrieb und Doppelhubraum.
Raupen	Aus Stahl mit geformten Blöcken. Breite: 700 mm.

OBERWAGEN

Ausleger	5 Elemente.
Heben	1 hydraulischer Hebebock mit Doppelwirkung. Neigung des Auslegers von -2° bis $+78^{\circ}$.
Ausfahren	Das Element 2 wird den anderen gegenüber in unabhängiger Weise ausgezogen, die Elemente 3, 4 und 5 werden proportional und kontinuierlich ausgezogen. Auszugszylinder mit zwei voneinander unabhängigen Hubbewegungen mit Ketten- und Seilvorgelegensystem. Ausfahren bei Teilbelastung möglich.
Winde	Axialkolben-Hydraulik-Motor mit fester Fördermenge und Planetenumsetzungsgetriebe. Die Absenkbewegung wird automatisch von einer Negativbremse gebremst. Mit Seilklemme ausgestattet. Zwei Drehgeschwindigkeiten. Seildurchmesser 16 mm, Länge 185 m (maximales Hubvermögen 4500 daN). Optionale Zusatzwinde (maximales Hubvermögen 3800 daN), Seildurchmesser 15 mm Länge 150 m.
Gegengewicht	Die 2 Teile sind demontierbar (linkes Gegengewicht wiegt 4700 Kg / rechtes Gegengewicht wiegt 4500kg).
Schwenkung	Dauernde 360° -Schwenkung durch hydraulischen Motor und Planetenumsetzungsgetriebe auf Drehplatte mit doppelter Kugeldrehung und Innenverzahnung. Automatische Negativbremsung. Bremsenspernung zur direkten Anreihung des Auslegers auf der Senkrechten der zu hebenden Last.
Fahrerkabine	Gute Sicht, Schiebetür, Heizung. Vorder- und Deckscheibe mit Scheibenwischer. Deck- und Heckscheibe können geöffnet werden. Vollkommen einstellbarer Fahrersitz mit Stoßdämpfung und aufklappbaren Armlehnen, in denen die Manipulatoren für die Steuerung sämtlicher Bewegungen des Krans angebracht sind.
Schutzvorrichtungen	Sperrventile an den Hebeböcken für die Aus- und Einfahr- bzw. Hebebewegung des Auslegers und auf den Stützauslegern. Drucksperrventile an jeder Hydraulikleitung. Ausgleich- und Bremsventil auf der Schwenkeinheit. Ausgleich- und Bremsventil an der Winde. Endschalter am Auslegerkopf für die Hebebewegung des Blocks. Endschalter, damit stets drei Seilwicklungen auf der Winde vorhanden sind. Lastmomentbegrenzer mit folgenden Angaben: Auslegerneigung Auslegerlänge Hublast maximales Hubvermögen Einstellmöglichkeit der Bewegungsbegrenzung des Teleskoparms.

ANLAGEN

Hydraulische Anlage	Speisung: 1 Dreifachzahnradpumpe und 2 Kolbenpumpen mit veränderbarem Hubraum. Bewegungssteuerung: durch hydraulische Manipulatoren gesteuerte Verteiler; gleichzeitige Proportionalbewegungen möglich. Raupensteuerung: Durch Fußsteuerungen mit Hebeln gesteuerte Verteiler. Filtration: 2 Filter mit Filterkartusche an der Rückleitung und 2 Filter an der Ansaugleitung der Kolbenpumpen.
Elektrische Anlage	24 V mit Wechselstromgenerator zu 70 A und 2 Akkumulatoren zu 132 Ah.

HAUTAUSSTATTUNG

1-teilige Spitze, 8 m. Einstellbereich: 0° , 20° , 40°
Klimaanlage (warm / kalt) in der Fahrerkabine
Set für den Betrieb bis zu -20°C
Set für den Betrieb bis zu $+45^{\circ}\text{C}$
Optionale Zusatzwinde
Unterflasche 10 t
Haken 5 t

Bei Ihrem gebietszuständigen Händler können Sie eine vollständige Liste der Optionals anfragen.

DIAGRAMMA DI LAVORO / WORKING RANGES / DIAGRAMME DE TRAVAIL / ARBEITSBEREICHE











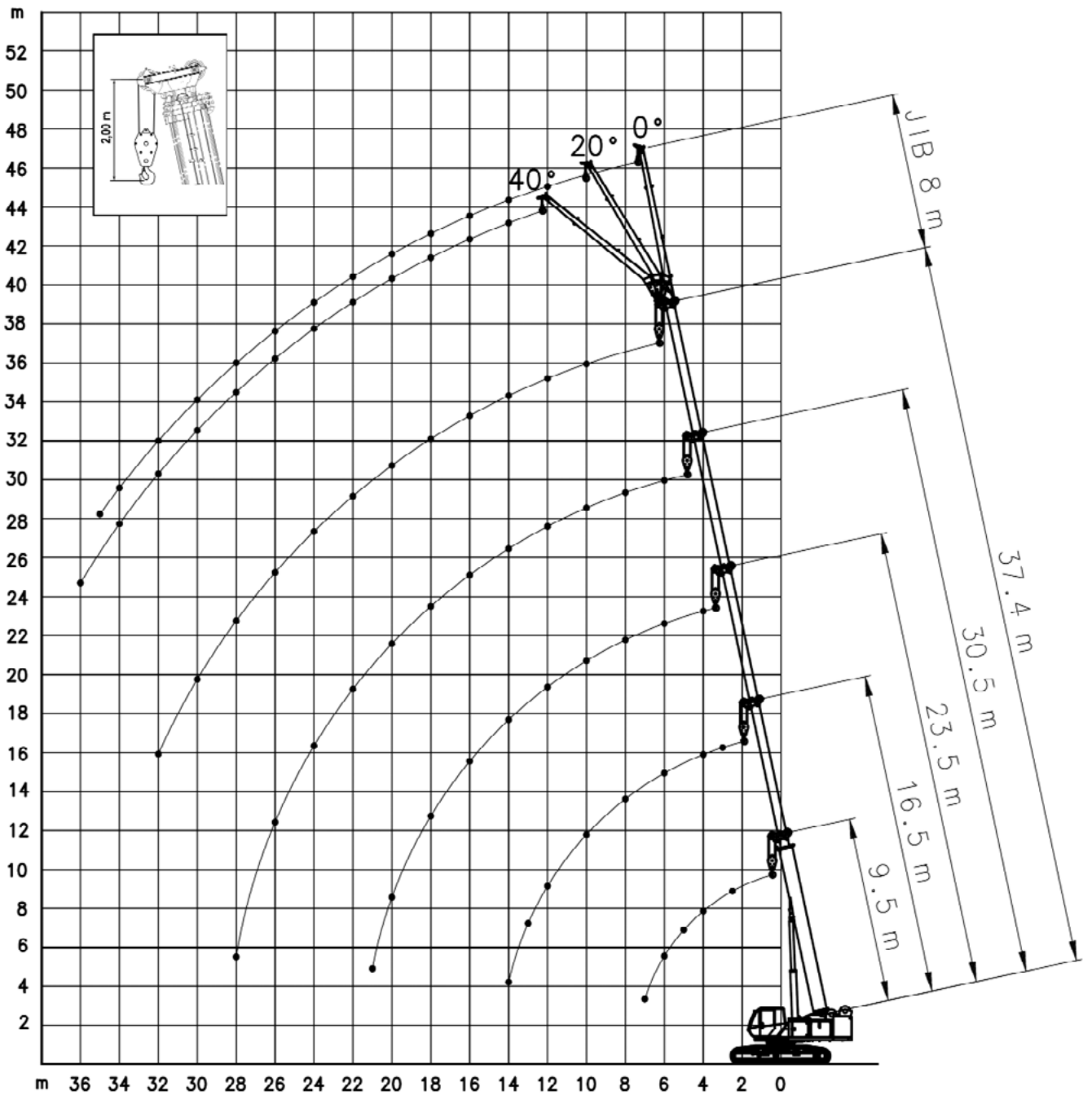
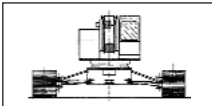

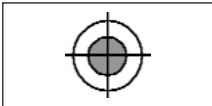
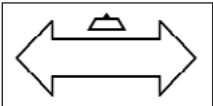

TABELLE / CHART / TABLEAU / TABELLE



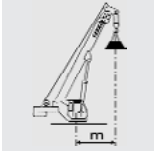
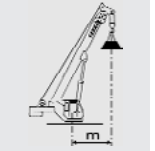



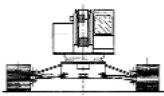

4.5m	360°	max 4°	0 Km/h	9.5m ÷ 23.5m	

	t2 = 0%	t2 = 0%	t2 = 0%	t2 = 0%	t2 = 0%	
	t3 = 0%	t3 = 17%	t3 = 33%	t3 = 49%	t3 = 67%	
	t4 = 0%	t4 = 17%	t4 = 33%	t4 = 49%	t4 = 67%	
	t5 = 0%	t5 = 17%	t5 = 33%	t5 = 49%	t5 = 67%	
	9.5 m	13.0 m	16.5 m	19.8 m	23.5 m	
	41.75	27.85	17.90	13.10	8.65	
2.5	41.75					2.5
3.0	32.45	27.85				3.0
3.5	26.25	23.15				3.5
4.0	21.95	19.70	17.90			4.0
4.5	18.80	17.10	15.70			4.5
5.0	16.55	15.05	14.00	13.10		5.0
6.0	13.00	12.20	11.35	10.75		6.0
7.0	10.80	10.00	9.50	9.10	8.65	7.0
8.0		8.50	8.15	7.80	7.45	8.0
9.0		7.35	7.05	6.80	6.55	9.0
10.0		6.50	6.20	6.00	5.80	10.0
11.0			5.50	5.35	5.15	11.0
12.0			4.95	4.80	4.65	12.0
13.0			4.40	4.25	4.15	13.0
14.0			4.05	3.90	3.80	14.0
15.0				3.55	3.50	15.0
16.0				3.25	3.15	16.0
17.0				3.00	2.90	17.0
18.0					2.70	18.0
19.0					2.50	19.0
20.0					2.30	20.0
21.0					2.20	21.0
22.0						22.0
23.0						23.0
24.0						24.0
25.0						25.0

TABELLE / CHART / TABLEAU / TABELLE

					
4.5m	360°	max 4°	0 Km/h	9.5m ÷ 23.5m	

	t2 = 0%	t2 = 0%	t2 = 0%	t2 = 0%	t2 = 0%	
	t3 = 0%	t3 = 17%	t3 = 33%	t3 = 49%	t3 = 67%	
	t4 = 0%	t4 = 17%	t4 = 33%	t4 = 49%	t4 = 67%	
	t5 = 0%	t5 = 17%	t5 = 33%	t5 = 49%	t5 = 67%	
	9.5 m	13.0 m	16.5 m	19.8 m	23.5 m	
						
	13.15	9.55	6.70	5.10	3.55	
2.5	13.15					2.5
3.0	11.80	9.55				3.0
3.5	10.65	8.70				3.5
4.0	9.70	8.00	6.70			4.0
4.5	8.90	7.40	6.25			4.5
5.0	8.55	6.85	5.85	5.10		5.0
6.0	7.45	6.00	5.20	4.55		6.0
7.0	6.95	5.35	4.60	4.00	3.55	7.0
8.0		4.80	4.05	3.65	3.25	8.0
9.0		4.40	3.70	3.30	3.00	9.0
10.0		4.10	3.40	3.00	2.70	10.0
11.0			3.15	2.75	2.50	11.0
12.0			2.95	2.55	2.30	12.0
13.0			2.80	2.40	2.15	13.0
14.0			2.75	2.25	2.00	14.0
15.0				2.15	1.85	15.0
16.0				2.05	1.75	16.0
17.0				2.00	1.65	17.0
18.0					1.55	18.0
19.0					1.50	19.0
20.0					1.45	20.0
21.0					1.45	21.0
22.0						22.0
23.0						23.0
24.0						24.0
25.0						25.0

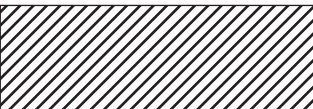
				
Cingoli aperti Crawler open Chenilles sorties Raupen ausgefahren	Cingoli chiusi Crawler closed Chenilles rentrées Raupen eingefahren	Angolo rotazione sovrastruttura Upperstructure angle rotation Angle rotation structure du dessus Drehwinkel des Strukturaufbaus	Inclinazione massima ammessa della macchina Maximum allowed machine inclination Inclinaison maximum admise de la machine Maximale zugelassene Neigung der Maschine	Braccio telescopico Telescopic boom Flèche télescopique Teleskoparm
				
Traslazione impedita Transfer disabled Déplacement interdit Transfer gehemmt	Traslazione con carico su 360° Transfer with load over 360° Déplacement avec charge à 360° Transfer mit Last auf 360°	Prolunga / Jib Extension / Jib Extension / Jib Verlängerung / Jib	Non movimentare carichi in queste zone No load handling in these zones Ne pas manipuler de charges dans ces zones Keine Lasten in diesen Bereichen bewegen	

TAGLIE DI SOLLEVAMENTO / HOIST REEVING / MOUFLAGE / HUBROLLEN

N° di taglie / No. of line Nbr. de brins / Seilanzahl	1	2	3	4	5	6	7	8	9	10
--	---	---	---	---	---	---	---	---	---	----

ARGANO PRINCIPALE / MAIN WINCH / TREUIL PRINCIPAL / HAUPTWINDE

Carico massimo in kN / Max line pull in kN Charges maxi en kN / Höchstlast in kN	45	90	135	180	225	270	315	360	405	450
---	----	----	-----	-----	-----	-----	-----	-----	-----	-----

ARGANO AUSILIARIO / AUXILIARY WINCH / TREUIL AUXILIAIRE / ZUSATZWINDE

Carico massimo in kN / Max line pull in kN Charges maxi en kN / Höchstlast in kN	38	76	114	152	190	228	266	304	342	380
---	----	----	-----	-----	-----	-----	-----	-----	-----	-----

NOTE	NOTES	NOTES	HINWEISE
<p>I carichi indicati costituiscono i valori massimi coperti dalla garanzia del costruttore per utilizzo rispettivamente secondo le norme della Unione Europea (CE). Sono espressi in tonnellate metriche ed includono il peso del bozzello, delle eventuali prolunghie applicate al braccio e di tutti gli accessori di sollevamento (brache, ecc.)</p> <p>Le operazioni di sollevamento nella configurazione su cingoli devono essere effettuate su superficie piana e solida.</p>	<p>The indicated loads are the maximum covered by the manufacturer's warranty for a use which complies with current EU directives (CE) standard. Weights are given in metric tons. They include the weight of the block, all extensions fitted to the boom and all lifting accessories (slings and so on).</p> <p>Crane on tracks: operate the crane on a steady flat surface when hoisting loads.</p>	<p>Les charges indiquées constituent les valeurs maximales couvertes par la garantie du fabricant pour une utilisation conforme aux normes de l'Union Européenne. Elles sont exprimées en tonnes métriques et comprennent le poids de la moufle, des éventuelles extensions appliquées à la flèche et de tous les accessoires de levage (élingues, etc.).</p> <p>Les opérations de levage dans la configuration sur chenilles doivent être effectuées sur une surface plate et solide.</p>	<p>Die angegebenen Lasten sind die Grenzwerte, für welche die Herstellergarantie bei Einsatz gemäß den Normen der Europäischen Union (EU) gültig ist. Die Grenzwerte sind in Metertonnen ausgedrückt, das Gewicht des Blocks, eventueller am Ausleger angebrachter Verlängerungen und jeglicher Hebezubehörteile (Schlingen usw.) ist inbegriffen.</p> <p>Hebearbeiten mit Raupenkrane müssen auf einer ebenen und festen Oberfläche erfolgen.</p>

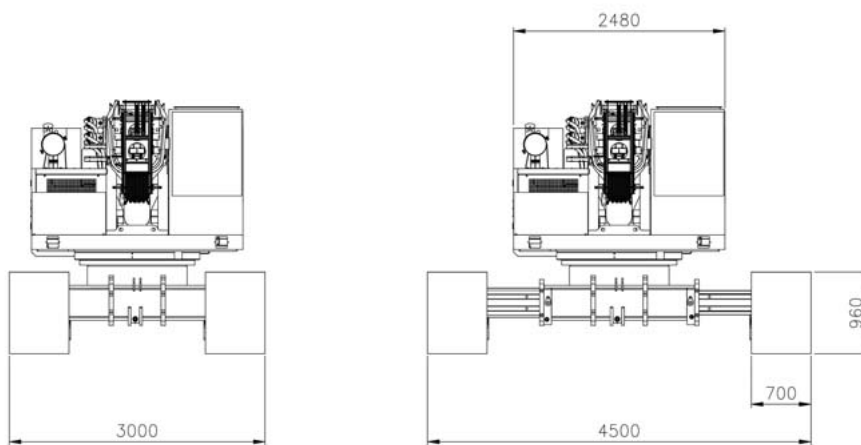
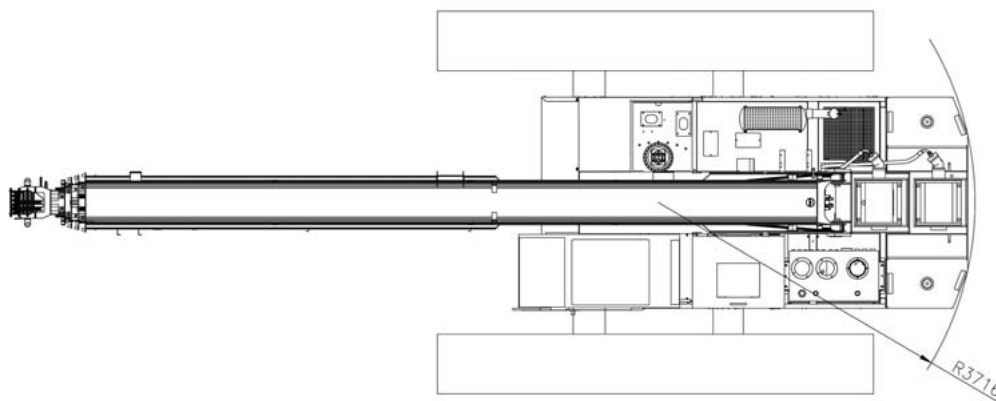
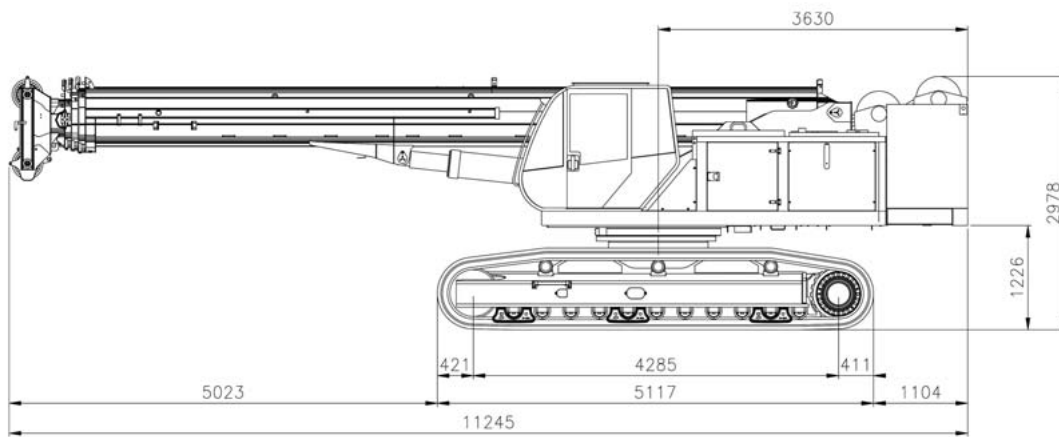

Dimensioni medie di riferimento fornite a puro titolo indicativo. Valori espressi in millimetri
Average reference values, which are indicative only. Values are expressed in mm

Dimensions moyennes de référence fournies à titre purement indicatif. Valeurs exprimées en millimètres
Durchschnittsmaße; dienen ausschließlich als Richtwerte. Die Werte sind in Millimetern ausgedrückt

NOTE

Ci riserviamo il diritto di modificare le specifiche e i prezzi dei prodotti in ogni momento e senza preavviso. Le fotografie e/o i disegni contenuti in questo documento sono destinati unicamente a scopi illustrativi. Consultare le istruzioni sull'uso corretto di questo macchinario contenute nell'opportuno Manuale d'uso. L'inottemperanza delle istruzioni contenute nel Manuale d'uso del macchinario e altri comportamenti irresponsabili possono provocare gravi lesioni, anche mortali. L'unica garanzia applicabile ai nostri macchinari è la garanzia scritta standard applicabile al particolare prodotto e alla particolare vendita; Terex è esonerata dal fornire qualsiasi altra garanzia, esplicita o implicita. I prodotti e servizi elencati possono essere dei marchi di fabbrica, marchi di servizio o nomi commerciali di TEREX Corporation e/o società affiliate negli Stati Uniti d'America e altre nazioni e tutti i diritti sono riservati. "TEREX" è un marchio registrato di Terex Corporation negli USA e molti altri Paesi. Copyright © 2007 Terex Corporation.

NOTES

Product specifications and prices are subject to change without notice or obligation. The photographs and/or drawings in this document are for illustrative purposes only. Refer to the appropriate Operations Manual for instructions on the proper use of this equipment. Failure to follow the appropriate Operations Manual when using our equipment or to otherwise act irresponsibly may result in serious injury or death. The only warranty applicable to our equipment is the standard written warranty applicable to the particular product and sale and Terex makes no other warranty, express or implied. Products and services listed may be trademarks, service marks or trade-names of Terex Corporation and/or its subsidiaries in the USA and other countries. All rights are reserved. Terex® is a registered trademark of Terex Corporation in the USA and many other countries. Copyright 2007 Terex Corporation.

NOTES

Les spécifications et prix des produits sont sujets à modification sans avis ou obligation. Les photographies et/ou dessins contenus dans ce documents sont uniquement pour illustration. Veuillez vous référer à la notice d'utilisation appropriée pour les instructions quant à l'utilisation correcte de cet équipement. Tout manquement au suivi de la notice d'utilisation appropriée lors de l'utilisation de notre équipement ou tout acte autrement irresponsable peut résulter en blessure corporelle sérieuse ou mortelle. La seule garantie applicable à notre équipement est la garantie standard écrite applicable à un produit et à une vente spécifique. Terex n'offre aucune autre garantie, expresse ou implicite. Les produits et services proposés peuvent être des marques de fabrique, des marques de service ou des appellations commerciales de Terex Corporation et/ou ses filiales aux Etats Unis et dans les autres pays, et tous les droits sont réservés. "TEREX" est une marque déposée de Terex Corporation aux Etats Unis et dans de nombreux autres pays. Copyright 2007 Terex Corporation.

HINWEISE

Produktbeschreibungen und Preise können jederzeit und ohne Verpflichtung zur Ankündigung geändert werden. Die in diesem Dokument enthaltenen Fotos und /oder Zeichnungen dienen rein anschaulichen Zwecken. Anweisungen zur ordnungsgemäßen Verwendung dieser Ausrüstung entnehmen Sie bitte dem zugehörigen Betriebshandbuch. Nichtbefolgung des Betriebshandbuchs bei der Verwendung unserer Produkte oder anderweitig fahrlässiges Verhalten kann zu schwerwiegenden Verletzungen oder Tod führen. Für dieses Produkt wird ausschließlich die entsprechende, schriftlich niedergelegte Standardgarantie gewährt. Terex leistet keinerlei darüber hinaus gehende Garantie, weder ausdrücklich noch stillschweigend. Die Bezeichnungen der aufgeführten Produkte und Leistungen sind gegebenenfalls Marken, Service-marken oder Handelsnamen der Terex Corporation und/oder ihrer Tochtergesellschaften in den USA und anderen Ländern. Alle Rechte vorbehalten. "TEREX" ist eine eingetragene Marke der Terex Corporation in den USA und vielen anderen Ländern. Copyright 2007 Terex Corporation.

