

# NATIONAL N-85

## Truck-Mounted Articulating Cranes and Accessories

**Maximum Capacity: 14,400 Pounds (6.54 Metric Tons)**

**Reach Above Truck Frame: 34 Feet (10.4 Meters)**

**Reach Below Truck Frame: 20 Feet (6.1 Meters)**

**Horizontal Reach: 28 Feet 6 Inches (8.7 Meters)**



**America's Truck-Mounted  
Hydraulic Crane Leader**

# NATIONAL N-85

National is America's leading manufacturer of commercial truck-mounted telescoping and articulating cranes. We build cranes for a wide range of jobs. Nobody builds them better. Nationals are tough, durable, and dependable. They are designed for ease of operation.

With a National, you are assured a well-engineered, well-manufactured, and fully tested machine designed for your applications. At National, we put quality first. Our commitment to product quality is our pledge to provide our customers with reliable products designed to provide years of service.

The National N-85 is a high-capacity crane that can replace many pieces of general lifting, loading and construction equipment. Coupled with our full line of accessories, the N-85 performs many functions quickly and easily. Yet, it still gives you a payload-carrying truck. When not in use, the N-85 stows neatly behind the cab.

Put a National N-85 to work on your jobs. You will be impressed with its low cost and high productivity. It's the versatile alternative to whatever you're now using for general purpose lifting, loading and unloading.

- 14,400-pound (6.54 MT) capacity
- 34-foot (10.4 m) vertical reach
- 28-foot 6-inch (8.7) horizontal reach
- 20-foot (6.1 m) reach below truck frame
- Strong boom sections manufactured from low-alloy high-strength steel
- Extra-large-diameter greaseless pins at pivots
- Hard-chrome-plated cylinder shafts
- N-85/H21 with two hydraulic extensions to 21 feet (6.4 m) with one easy-to-handle pullout jib to 25 feet 1 inch (7.6 m)
- Dual waist-level controls
- Wide, fully-hydraulic outriggers
- Heavy-duty hydraulics
- Rack-and-pinion rotation for precision and durability
- Mounts on standard, single axle trucks

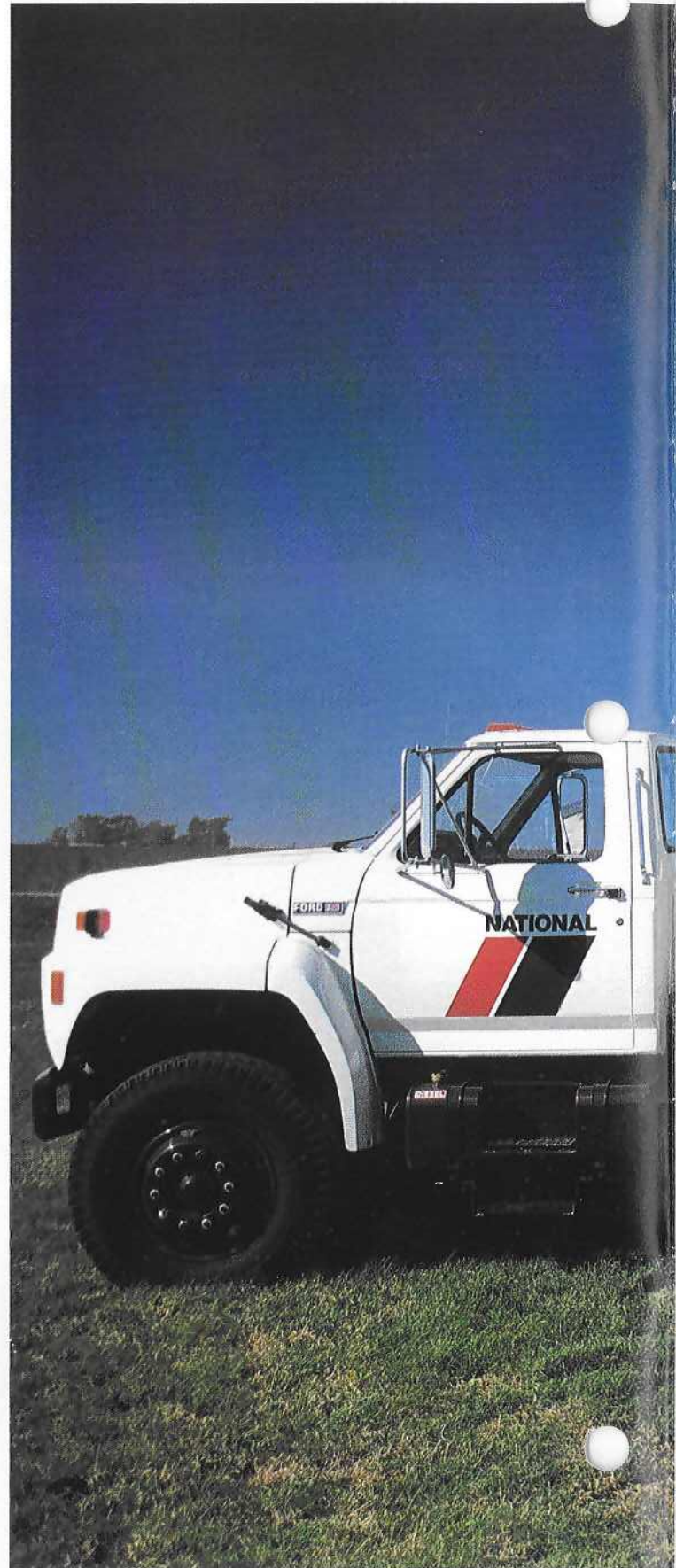



**NATIONAL CRANE CORPORATION**  
To provide our customers with products where Quality and Reliability are integral with design and manufacturing.  
**COMMITMENT TO QUALITY**





### Built strong

The National N-85 is designed for tough materials-handling jobs, so we manufacture it from extra-tough, low-alloy, high-strength steel.

We use extra-large-diameter greaseless pins at all pivot points. Cylinder shafts are hard-chrome plated. And high-pressure tubing is used wherever possible to reduce hose wear.

The heavy-duty wire-braided hydraulic hoses are routed inside structural members where possible for protection from bumps, twists, cuts and abrasions. Outrigger and jib cylinders are fully enclosed to prevent on-the-job damage and protect them from harsh weather conditions. Our special three-point mounting system absorbs loading flex, protecting the truck frame from excessive stress.

Every N-85 undergoes hundreds of quality control inspections, including ultrasonic testing for weld penetration. All prototype models are stress tested and run through thousands of brutal work cycles to make sure your N-85 will work year after year.

### Rack and pinion rotation

All National Articulating Cranes give you the precision and control of rack and pinion rotation. Our rack and pinion system is simple, reliable and, because it has few parts, easy to maintain. Service is easy. Rack and pinion rotation also reduces the bulk of the crane frame above the truck, lowering the center of gravity for greater stability.

### Wide, fully hydraulic outriggers for stability, fast set-up

Fully hydraulic outriggers are standard on the N-85 for fast, easy set-up from either side of the standard dual controls. Outriggers extend 12 ft. 1 $\frac{3}{4}$  in. (3.7 m) horizontally and 25 $\frac{1}{2}$  in. (65 cm) vertically. Wide stance and extra vertical travel, plus extra-large outrigger pads, give you extra stability even on soft or uneven ground.

Standard automatic check valves prevent settling of outriggers. The vertical cylinders lock automatically when stowed, so they will not leak down in transit.

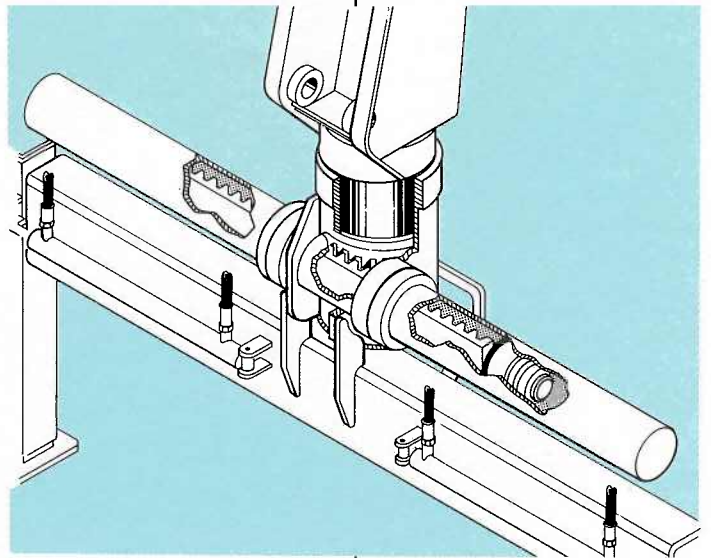

### Easy operation

The N-85 gives you waist-level dual controls without extra cost. The operator can work from either side of the crane and keep the boom and load in view at all times. The control knobs are illustrated with function symbols and operate smooth, fine-metering, five-spool control valves for pinpoint accuracy. The boom can be worked and rotated simultaneously. You won't find a crane that's easier to use. Additional valve banks can be added easily for operating any of our many hydraulic accessories.



### Heavy-duty hydraulics

All N-85 couplings and fittings are high quality and all cylinders are double-acting for smooth, positive control. High-capacity, heavy-duty pumps are standard and our specially-designed oil tanks are detachable for quick, easy maintenance.

### American-made

All National cranes are built in America from American-made components. Parts are readily available and service is easily obtained, should you need it.



**Caution**  
Do not operate crane booms, jib extensions, any accessories, or loads within 10 feet (3m) of live power lines. Jib and boom capacities shown are maximum for each section. Do not exceed capacities at reduced radii.

### The National Testing Program

National Crane established its original product durability standards by carefully evaluating the performance of competitive machines. Taking the best performances from these tests, National engineers set their own standards **more than 50% higher!** This is the same testing program each National must pass today.

Before a new model is released for production manufacturing it is subjected to state-of-the-art testing. For example, a plastic-based "brittle lacquer" coating is applied to the boom. After loading the boom, test engineers inspect the coating for cracks. The special lacquer has virtually no elastic qualities, so stretching or deformation of the metal shows up in "fractures" of the coating, perpendicular to the direction of stretching.

This procedure indicates where engineers are to place strain gauges, tiny chips printed with electronic circuitry which expand or

contract with changes in the metal. Minute changes in electrical resistance are measured by a computerized strain gauge monitor and printed out for engineering studies. These strain gauges measure current fluctuations as small as one-millionth of an ohm—which measures metal deformation as small as one-millionth of an inch.

After strain gauge testing, the prototype of each new model undergoes life-cycle testing. The crane is operated at full-load through a full life-cycle under close scrutiny. Outriggers, frames, and other components are loaded and rotated through a complete range of motion for the prescribed number of cycles.

More than 400 individual quality control inspections are made on each National crane during manufacture and assembly. National attention to testing ensures that each crane delivered to the field is as close to perfect as state-of-the-art technology permits.

# National N-85 Articulating Cranes

## N-85 Lift and Reach Capabilities

Lifting capacities shown at each length are maximum allowable loads, including the weight of any attached accessories

Foot/pound rating at 6 ft. 3 in.: 90,000  
(Shaded extensions denote Model 29.)

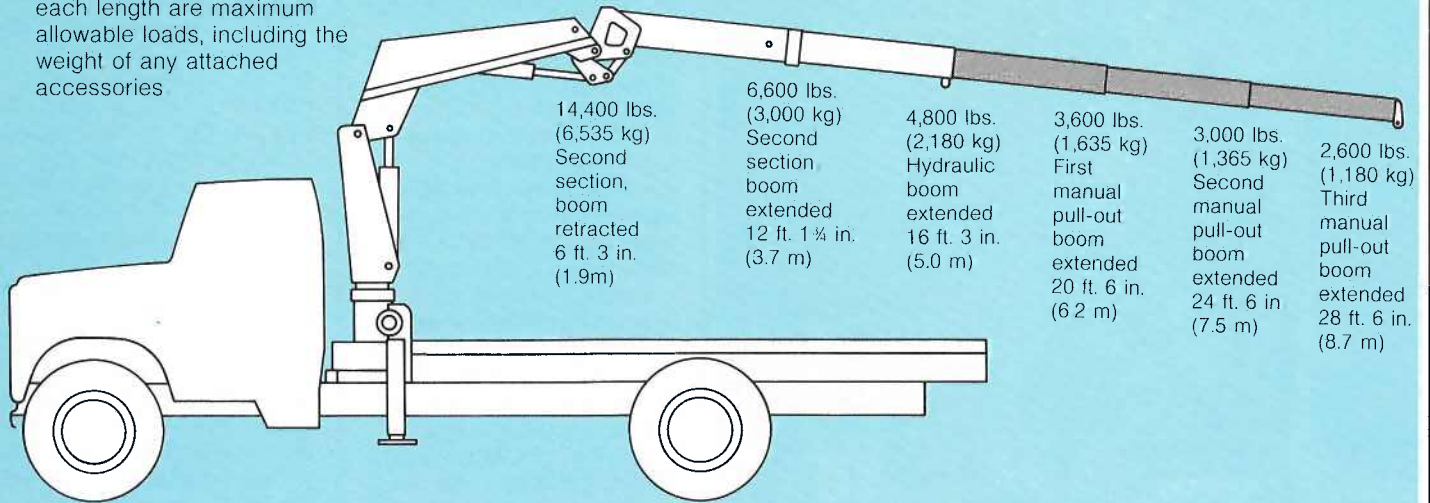

**Jib and boom capacities shown are maximum for each section. Do not exceed capacities at reduced radii.**

### The Basic Unit (Model 16)\*

- Hydraulic reservoir
- Two hydraulic outriggers with hydraulic extension to 12' 1 1/4" (3.7 m) span
- Frame, inner boom, outer boom with one hydraulic extension to 16' 3" (5 m)
- 390° rotation
- Five spool control valves
- Safety relief valves on inner boom to help protect against overload
- Boom cylinders have excess flow check valves to help prevent load drop in case of line failure; plus automatic check valves on outriggers
- Dual controls
- Crane hook
- Hydraulic pump and easy mounting group

\*Model 29 is the same as the basic unit but with manual pull-out booms providing a reach of 28' 6"

### Technical Data

Working Pressure	2,850 psi	194 bar
Pump Capacity (vane-type pump)	14 gallons/min	53 liters/min.
Reservoir Oil Capacity	19 gallons	72 liters
Outrigger Span	12' 1 1/4"	3.7 m
Stowed Height (above truck frame)	7' 3"	2.2 m
Weight (85/16)	4,650 lbs.	2,109 kg
Filter	10 micron replaceable (spin-on type) filter	
Rotation	390°	390°
Mounting Space Required	34"	87 cm

### Maximum reach (Model 29)

- Above truck frame to 34 feet (10.4 m)
- Below truck frame to 20 feet (6 m)
- Horizontal to 28 feet 6 inches (8.7 m)

### Special Safety Features

- Special overload relief valves
- Dual hydraulic controls
- Double-acting cylinders
- Excess flow check valves to help prevent load drop due to line failure.
- Pilot operated outrigger check valves (standard)



(Shaded extension denotes manual pull-out.)

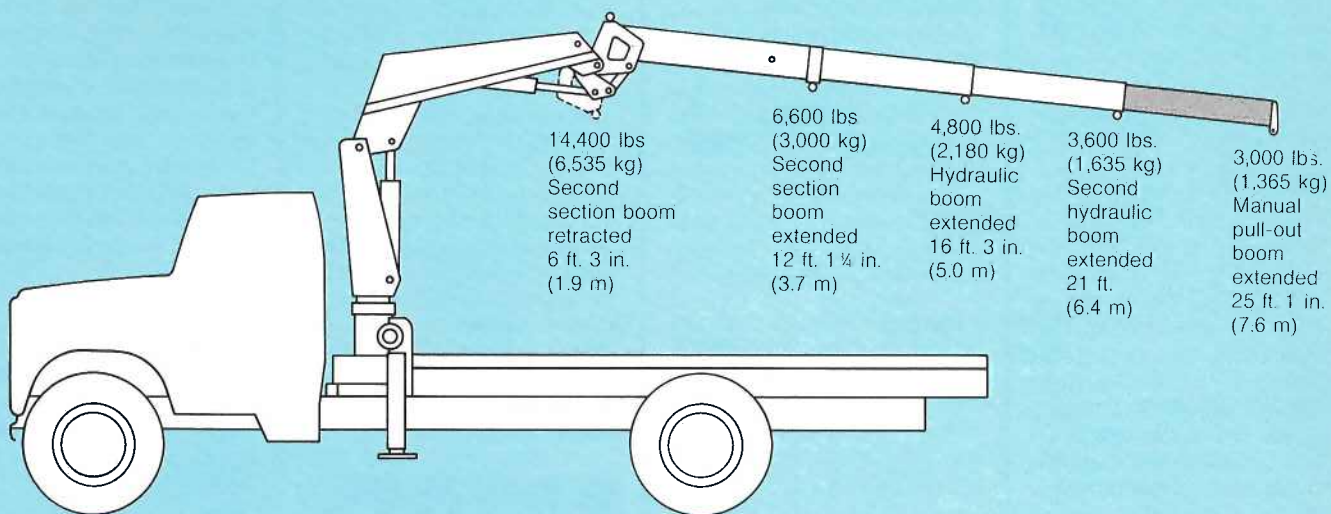

**Jib and boom capacities shown are maximum for each section. Do not exceed capacities at reduced radii.**

### H21 Hydraulic Extension Option (Model H21)

Add extra versatility to your N-85 by specifying the H21 option. It replaces the standard manual pull-out booms with the two all-hydraulic extensions and a manual pull-out extension.

The hydraulic extensions retract and extend under full load up to 21 feet (6.4 m). The manual pull-out extends the reach to 25 feet 1 inch (7.6 m). Held in or out with a single pin, the manual pull-out is quick to rig, easy to use.

#### Maximum Reach

- Above truck frame to 30 feet (9.2 m)
- Below truck frame to 15 feet (4.6 m)
- Horizontal to 25 feet 1 inch (7.6 m)



# National N-85 Options and Accessories

Every National N-85 is more than just a crane. It's part of a complete lifting system.

The National Lifting System equips your crane to do more than just lift or handle materials. The accessories shown here enable one truck-mounted N-85 to perform jobs that typically require a whole fleet of specialized, expensive vehicles. With a National, you can do more, faster, with less equipment and less manpower. That's money in your pocket.

**NOTE:**

Weights of all accessories attached to the boom or loadline of the crane must be deducted from the effective lifting capacity. Some accessories cannot be used in combination with other accessories. Consult your dealer for specific accessory availability.

### Seated Controls

Make work faster and easier for your operators with National seated controls. Located at the top of the mast for full vision of crane and load. Reduces operator fatigue, maximizes work output. Includes six valves for fold, lift, turn, extend and two accessory functions. Control knobs illustrate functions. Replaces dual side controls. Not available with remote controls or holding valve option.

**Model SC**



### One Person Basket

This strong, lightweight fiberglass basket with 300-pound capacity puts personnel where you want them for the occasional tough maintenance and installation jobs. Easy on-off. Safety belts included. Gravity or lock-type leveling.

**Capacity** .....300 lbs.  
**Weight** .....150 lbs.  
**Dimensions** .....22" x 22" x 42"  
**Construction** .....Fiberglass

**2 Models**

B1, gravity hung without lock  
 B1-L, gravity hung with swing lock

*Includes safety belt and lanyard. Cannot be used simultaneously with winch.*

**Model B1  
 Model B1-L  
 (with lock)**

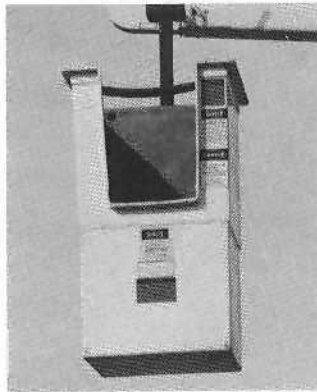

**Caution**

**Do not operate crane booms, jib extensions, any accessories, or loads within 10 feet (3m) of live power lines. Jib and boom capacities shown are maximum for each section. Do not exceed capacities at reduced radii.**

### Accessory Control Valves

These additional control units are required for the operation of hydraulic accessories. Comes complete with controls for both sides of your machine, hoses, quick couplers and piping to the end of the second boom section. Available in two models: AH1 single function for rotator or auger and AH2 (pictured) with two functions for grapple or clam bucket. Mount easily on existing control panel.

**Model AH1  
 Model AH2**

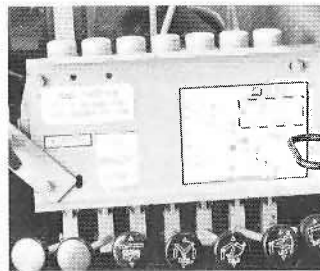

### Pilot Operated Holding Valves

Available in lieu of excess flow check valves. Locks oil in cylinder until hydraulic pressure pilots open holding valve allowing downward movement of the boom. Standard overload relief protection does not function with this option.

### Remote Control

The latest edition of our one-hand remote control. Ideal for use where precise control and total load visibility are required. Fine metering and instant response enables operators to position loads easily.

Now, it's more reliable than ever with solid state circuitry and fewer parts than previous systems we have offered. Other improvements include higher operating speeds and modular design. Works with standard dual controls. MR4 for lift, turn, fold and extend. MR5 is the same as MR4, plus one accessory. MR6 is the same as MR4, plus two accessories.

Priority control valve operated by a trigger on the remote control unit, regulates oil flow and gives you fingertip speed control over all crane functions.

National remote control is the easy, lightweight way to add extra versatility to your N-85.

**Model MR4  
 Model MR5  
 (Requires one accessory)  
 Model MR6  
 (Requires two accessories)**

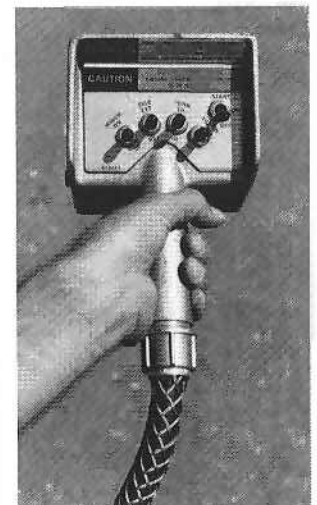



### Winch

Optional National winch increases the versatility of your crane. Extra-capacity, heavy-duty winch handles up to 4,100 pounds (1,860 kg). Easy single-pin attachment of boom-tip sheave head. Includes winch control.

### Model N4

#### Line Pull

1st wrap ..... 4,100 lbs.  
2nd wrap ..... 3,700 lbs.  
3rd wrap ..... 3,400 lbs.

#### Speed

1st wrap ..... 48 ft./min.  
2nd wrap ..... 54 ft./min.  
3rd wrap ..... 60 ft./min.

#### Cable

95 ft. of 7/16" rotation resistant cable.

#### Winch

7½" dia. drum, 12" dia. flange, 10" wide with safety brake. OSHA required 18:1 ratio drum diameter to cable diameter.

#### Sheaves

Run on roller bearings with OSHA required 18:1 ratio sheave diameter to cable diameter.

#### Controls

Includes hydraulic control valve and hoses to winch.

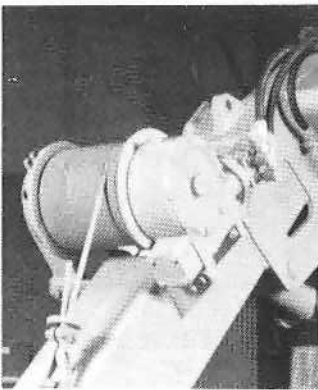

### Hydraulic Auger

This popular N-85 accessory gives you digging depths to 4½ feet (1.8 m) and flightings up to 18 inches (46 cm). Attaches easily, works fast and disconnects quickly. Requires 14 gpm (53 L/min) pump and AH1 Accessory Control Valve group. Optional extension will provide a digging depth to 6½ feet (2.4 m). Contact factory for details.

Reach ..... 16' 3"  
Reduction ..... 4:1  
RPM ..... 70 rpm at 14 gpm  
Pressure ..... 2,850 psi  
Pump ..... 14 gpm required  
Torque Output ..... 1,450 ft./lbs.  
Drive Weight ..... 205 lbs.  
Length ..... 48" overall  
Controls ..... Requires AH1 hydraulic control valve option

#### Flightings and Weight:

Flightings	Length	Weight
9" .....	30" double flighting	.66 lbs.
12" .....	30" double flighting	.78 lbs.
15" .....	30" double flighting	.92 lbs.
18" .....	30" double flighting	1.23 lbs.
24" .....	30" double flighting for high performance auger only	152 lbs.
24" .....	9" long, 12" diameter bottom flighting	
	18" long, 24" diameter top-flighting	
	42" overall length for high performance auger only	146 lbs.

### Model AG Model AGHP (high performance)

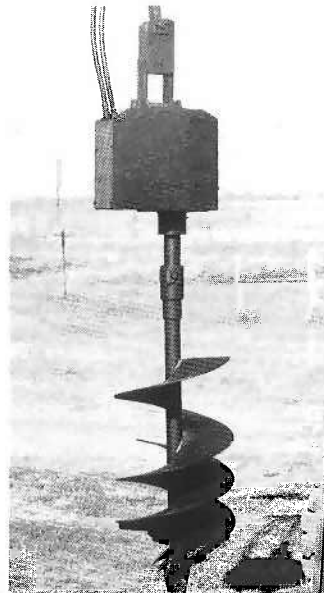

### Pallet Fork

Turns your N-85 into a versatile, payload-packing fork lift. Great for delivering palletized materials where you want them. 4,400 pounds (1,996 kg) capacity with adjustable throat and teeth. Handles most loads with ease. Available with hydraulic leveling or with a manual slide collar for leveling. For extra versatility, specify a National Hydraulic Rotator.

Capacity ..... 4,400 lbs.  
Throat Opening ..... 41" to 65" (adjustable)

Tooth Length ..... 38½"  
Tooth Width ..... 33.5" to 57" (outside to outside) min. max.

#### Weight

MKF ..... 300 lbs.  
HKF ..... 350 lbs.  
HKFR ..... 435 lbs.

### Model MKF

(Manual leveling, adjustable throat)

### Model HKF

(Hydraulic leveling, adjustable throat)

Requires AH1

### Model HKFR

(Hydraulic leveling, adjustable throat with hydraulic rotator)

Requires AH2

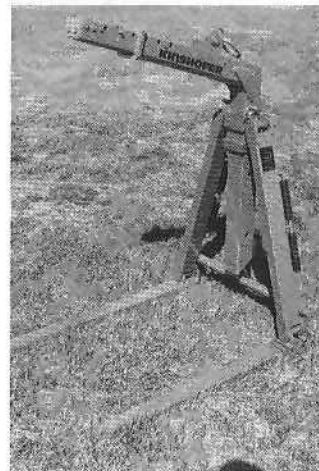

### Clam Bucket and Grapples

Turn your N-85 into more than a crane with National clam bucket or grapple attachments. The clam bucket can be used to load or move loose materials in 1/3 cubic yard (.25 m³) bites. The grapples, available in butt or bypassing type, will get a grasp on difficult handling jobs. Butt type handles up to 1/3 cord, bypassing will pick up 36-inch (91 cm) log or pipe. One person can install and remove bucket or grapples easily. Both come with hydraulic rotator and quick-connect fittings. Require AH-2 Accessory Control Valves.

	Butt Type	By-passing	Clam
Capacity	1/3 cord	36" log or pipe	1/3 yd.
Rotation	315°	315°	315°
Opening			
Max.	72"	66"	72"
Min.	30"	6"	
Weight	590 lbs.	510 lbs.	520 lbs.
Height			
Open	38"	41"	38"
Closed	58"	54½"	58"
Width	Teeth	Teeth	Width
	20"	20"	36"
	Front 12"		
	Back 20"		
	(2.3" wide teeth, 14" apart)		

### Clam Bucket Model GPC Butt Grapple Model BTG Bypassing Grapple Model BPG



# National N-85 Mounting Specifications

## Mounting

It is essential that the truck used for mounting this crane meet these minimum requirements for capacity loads

This vehicle will permit lifting capacity loads in all areas around the rear of the vehicle in a 180° arc from outrigger to outrigger. No load should be lifted over the front of the vehicle unless extra stabilizing provisions are made, such as the addition of front stabilizers or extra weight in truck bed.

If front axle chassis weight is less than 6,000 lbs., counterweight may be required to lift rated capacity loads and keep unit stable.

GAWR means Gross Axle Weight Rating and is dependent on all components of the vehicle such as axles, tires, springs, frame, etc., meeting manufacturers' recommendations. Always specify GAWR when purchasing trucks.

Minimum axle requirements may increase with use of diesel engines, longer wheelbase, or service bodies. Contact factory for further information.



## Minimum Truck Specifications

- Truck Weight ..... 13,750 pounds (6,250 kg) before crane installation  
Front Axle: 6,000 pounds (2,727 kg) before crane installation  
Rear Axle: 7,750 pounds (3,522 kg) before crane installation
- Rear of Cab to Front Axle ..... 78 inches (200 cm)
- Rear of Cab to Rear Axle ..... 126 inches (320 cm)
- Axle Ratings ..... Front: 10,860 pounds (4,936 kg) GAWR  
Rear: 18,500 pounds (8,409 kg) GAWR  
(Specify GAWR when ordering chassis)
- Minimum Wheelbase ..... 204 inches (518 cm)
- Frame ..... Minimum RBM of 1,050,000 inch/pounds (118,120 joules) with a minimum Section Modulus of 21 in.<sup>3</sup> (342 cm<sup>3</sup>)
- Frame Height ..... 42 inches (107 cm) or less is preferred
- Power Take Off ..... 70-85 percent of engine speed. Minimum H.P. 33 at 1,400 rpm

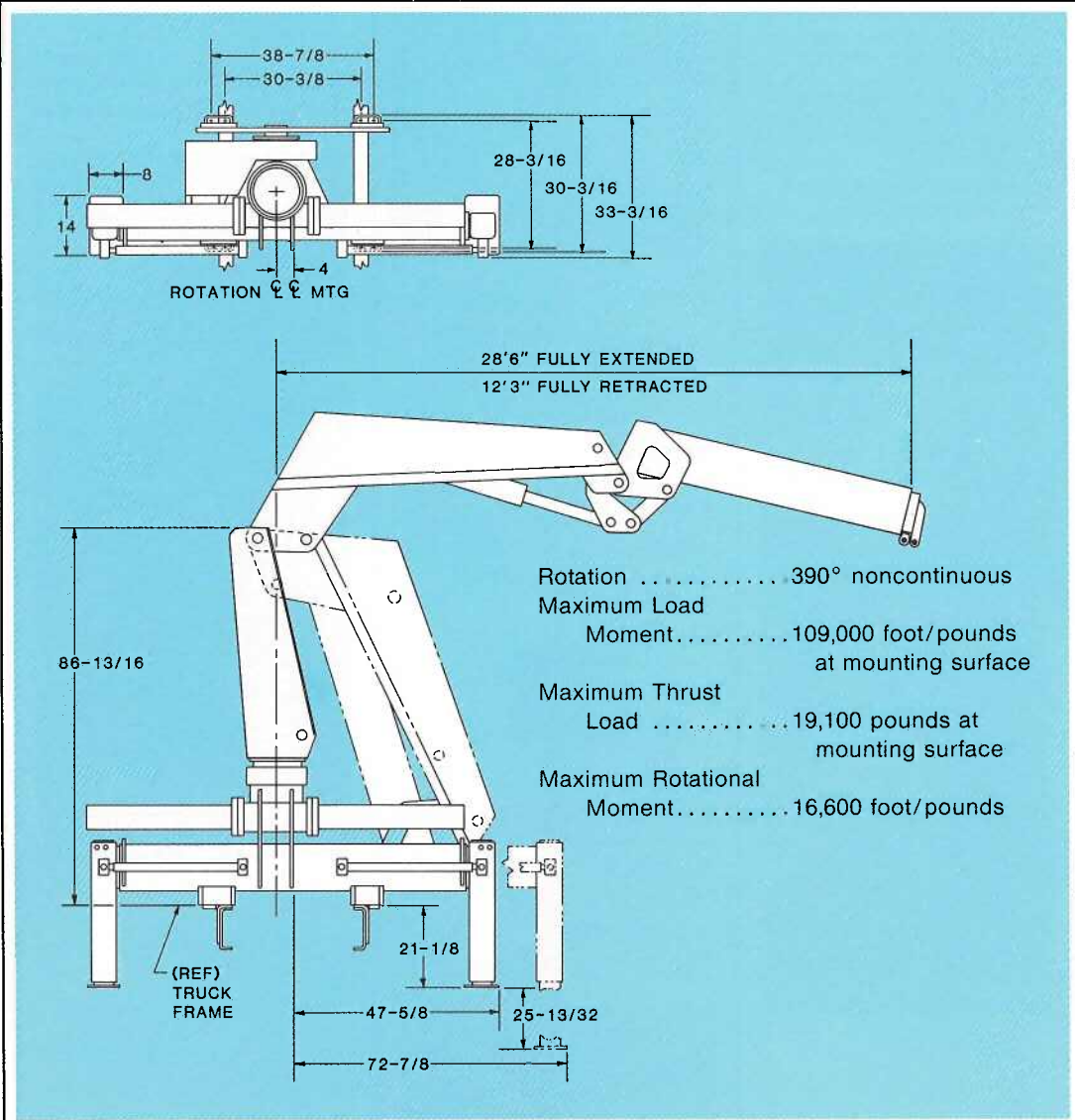



# National N-85 Proposal

	Description	Price
Date: _____	Basic N-85 N-85/16 <input type="checkbox"/>	\$ _____
Prepared for: _____	N-85/29 <input type="checkbox"/>	\$ _____
_____	N-85/H21 <input type="checkbox"/>	\$ _____
Submitted by: _____	<b>Options/Accessories:</b>	
_____	1. Optional controls <input type="checkbox"/> SC Seated Controls	\$ _____
_____	<input type="checkbox"/> MR4 Remote (not available with SC)	\$ _____
_____	<input type="checkbox"/> MR5 Remote (not available with SC)	\$ _____
_____	<input type="checkbox"/> MR6 Remote (not available with SC)	\$ _____
_____	2. Pilot Operated Holding Valves (not available with SC)	\$ _____
_____	3. Fiberglass Basket <input type="checkbox"/> B1 Gravity	\$ _____
_____	<input type="checkbox"/> B1-L Lock Type	\$ _____
_____	4. Auger AG85 <input type="checkbox"/> Standard	\$ _____
_____	Flighting: <input type="checkbox"/> 9" <input type="checkbox"/> 12" <input type="checkbox"/> 15" <input type="checkbox"/> 18" <input type="checkbox"/> 24"	\$ _____
_____	<input type="checkbox"/> High Performance <input type="checkbox"/> 24" Tree Planter	\$ _____
_____	5. Winch N4	\$ _____
_____	6. Pallet Fork <input type="checkbox"/> MKF Manual Leveling	\$ _____
	<input type="checkbox"/> HFK Hydraulic Leveling	\$ _____
	<input type="checkbox"/> MKFR Hydraulic Leveling with Hydraulic Rotator	\$ _____
	7. Grapples or Clam Bucket <input type="checkbox"/> BTG Butt	\$ _____
	<input type="checkbox"/> BPG Bypassing	\$ _____
	<input type="checkbox"/> GPC	\$ _____
	8. Accessory Valves <input type="checkbox"/> AH1 Single Control	\$ _____
	<input type="checkbox"/> AH2 Dual Control	\$ _____
	9. Other _____	\$ _____
	<b>Mounting:</b>	
	10. Installation <input type="checkbox"/> Std. <input type="checkbox"/> Spec.	\$ _____
	11. Frame reinforcing <input type="checkbox"/> Weld <input type="checkbox"/> Bolt-Extra	\$ _____
	12. Platform Bed _____ft. <input type="checkbox"/> Wood <input type="checkbox"/> Steel	\$ _____
	13. Weight in bed _____lbs. (if required)	\$ _____
	14. Chassis _____	\$ _____
	15. Rear Bumper Protection _____	\$ _____
	16. Back-up Alarm _____	\$ _____
	17. Freight _____	\$ _____
	This quotation will remain firm for _____ days.	\$ _____
		Sub Total
		\$ _____
		<b>Total Price</b>
Accepted by: _____	(Name) _____ (Title)	
_____	(Firm Name)	Date: _____

### The National Warranty

No product is better than its warranty. And no warranty is better than the company behind it.

We didn't get to be America's leading manufacturer of telescoping and articulating cranes by building less than the best. Or backing them with less than a comprehensive warranty.

Our warranty covers your crane against defects in materials or workmanship for 6 full months from the date of shipment, subject to the conditions of the warranty.

When you select a National crane, you're getting a nationwide dealer warranty service network, strong warranty protection and our special concern for every product we make.

Read our warranty. Then, don't settle for less. For complete information, write National Warranty Service, Waverly, NE 68462.

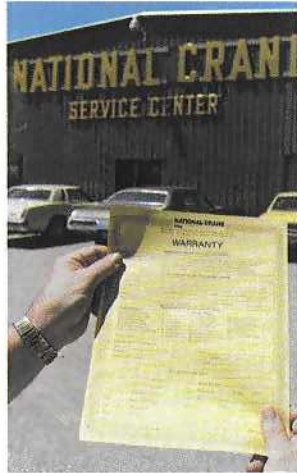

### The National Parts System

Authorized National Crane dealers maintain a parts supply to support the National cranes in each dealer's area. If a dealer cannot immediately supply a needed part, the factory can normally provide the part to the dealer within 48 hours on request. National's responsiveness to dealer requests means that your crane will be back on the job fast. National maintains a highly trained Service and Parts staff to answer dealer service questions and expedite parts shipping.

### The National Service Center

National maintains a fully equipped crane and truck service center where we do all our factory crane mounting. The central location of our Service center makes it easy to return cranes for special modifications or extreme repairs. Most National dealers can perform all but the most unusual modifications or most serious repairs.

Should you need to return your crane to us for modification, warranty repair or other service, we will give it priority care and see that it is returned as soon as possible.



### General Offices

11200 North 148th Street/Waverly, NE 68462/402/786-2240  
Telex: 438061

**Your National Dealer:**