

# Specifications

Hydraulic Rough Terrain Crane

## RTC-8028

28-ton (25.42 metric ton)

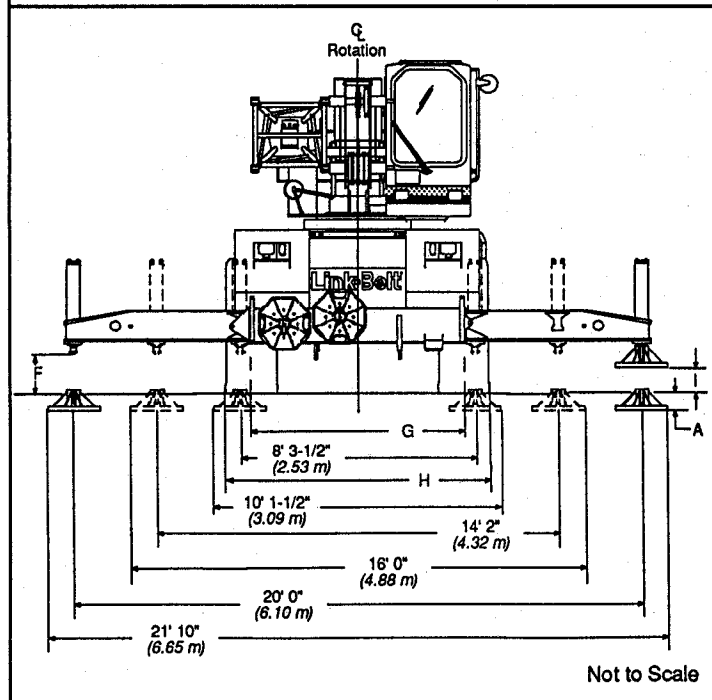
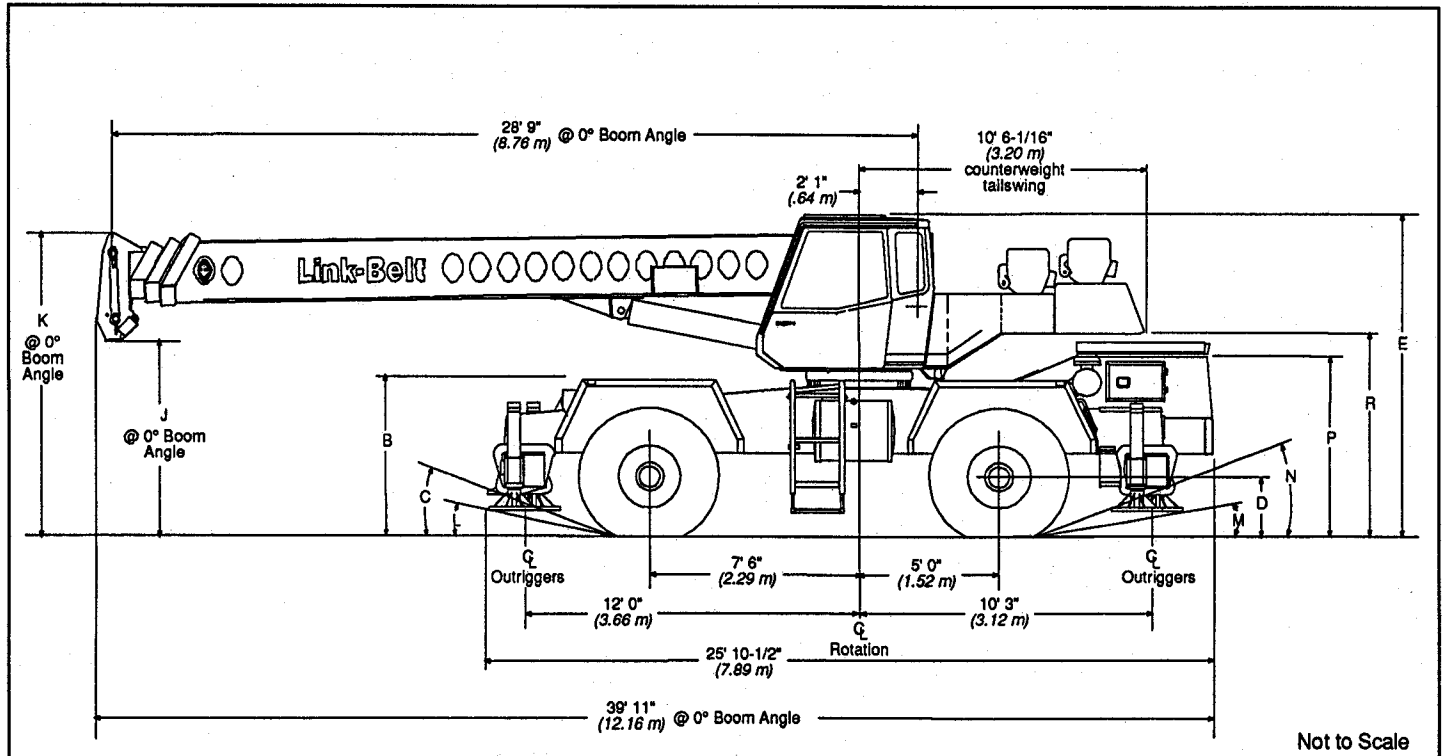

General dimensions	feet	meters
Turning radius (4-wheel steer - centerline of tires)	19' 4"	5.89
Turning radius (2-wheel steer - centerline of tires)	33' 2"	10.11
Turning radius (4-wheel steer - wall to wall)	31' 4"	9.55
Turning radius (2-wheel steer - wall to wall)	44' 1"	13.44
Turning radius (4-wheel steer - carrier clearance)	22' 8"	6.91

### Dimensions affected by tires

Tires	20.5 X 25 (24-PR)		23.5 X 25 (20-PR)	
	feet	meters	feet	meters
A	12.13"	.31	10.13"	.26
B	68.86"	1.75	70.86"	1.80
C	21.28°	-	23.5°	-
D	26.80"	.68	28.80"	.73
E	136.72"	3.47	138.72"	3.52
F	17.37"	.44	19.37"	.49
G	89.50"	2.27	88.50"	2.25
H	110.27"	2.80	113.75"	2.89
I	10.81"	.27	12.81"	.33
J	89.07"	2.26	91.07"	2.31
K	134.17"	3.41	136.17"	3.46
L	11.1°	-	13.23°	-
M	9.4°	-	11.25°	-
N	18.0°	-	19.9°	-
P	79.11"	2.01	81.11"	2.06
R	85.37"	2.17	87.37"	2.22

## Upperstructure

### ■ Boom

**Patented Design** - Base, center and tip section side plates have diamond shaped impressions for superior strength to weight ratio and 100,000 p.s.i. (689.5 MPa) steel angle chords for lateral stiffness. Boom telescope sections are supported by wear shoes both vertically and horizontally to prevent metal to metal contact.

**"LMI" Microguard 414, Rated Capacity Limiter** — Standard; Audio-visual warning system with anti-two block and function limiters. Operating data available includes boom length, boom angle, head height, radius of load, machine configuration, allowed load, actual load and percent of allowed load. Presettable alarms for maximum and minimum boom angles, maximum tip height, maximum boom length, swing left and swing right positions.

**Standard boom** — 28' 9" - 70' 3" (8.76 - 21.41 m) three-section full power boom.

**Optional boom** - 28' 9" - 91' (8.76 - 27.74 m) four section boom includes base section, two power sections, and manual fourth section. Fourth section is power pinned by manually activating a cylinder locking system.

**Boom head** — Four 10-5/8" (0.27 m) root diameter head sheaves handle up to 8 parts of wire rope. Rope dead end lugs provided on each side of boom head. Easily removable wire rope guards standard; one on top sheaves and one on bottom sheaves.

**Auxiliary lifting sheave** — *Optional*; Single 10-5/8" (0.27 m) root diameter sheave with removable wire rope guard, mounted to boom. For use with one or two parts of line off the optional auxiliary winch. Does not affect erection of fly, or use of main head sheaves for multiple reeving.

**Boom elevation** — One Link-Belt designed hydraulic cylinder with holding valve and bushings in each end. Hand control for controlling boom elevation from -3° to + 79.9°.

### ■ Fly

*Optional* — 25' (7.62 m) fixed stowable one piece lattice type.

*Optional* — 25' (7.62 m) offsettable (2°, 15°, or 30°) stowable one-piece lattice type.

*Optional* — 25' - 43' (7.62 m - 13.10 m) offsettable (2°, 15°, or 30°) stowable type lattice with telescoping box section.

### ■ Cab and Controls

Environmental ULTRA-CAB™ of LFC\*2000 construction process featuring laminated fibrous composite material; isolated from sound with acoustical fabric insulation, all tinted and tempered safety glass windows. Sliding rear and right side windows and swing up roof window for maximum visibility and ventilation. Slide-by-door opens to 36" (0.91 m) width. 6-way adjustable operator's seat for maximum operator comfort. Hydraulic control levers (joystick type) for swing, winches and boom hoist. Outrigger controls conveniently located in overhead control console; sight level bubble also provided in upper cab. Foot controls for boom telescope, swing brake, travel brake and engine throttle.

**Cab instrumentation** — Corner post mounted gauges for hydraulic oil temperature, air pressure, fuel, water temperature, voltmeter and oil pressure. Converter oil temperature gauge mounted in side console.

### ■ Swing

Bi-directional hydraulic swing motor mounted to a planetary reducer for 360° continuous smooth swing at 3.6 r.p.m.

**Swing parking brake** — 360°, electric over hydraulic (spring applied, hydraulic released) multi-disc brake mounted on the speed reducer. Operated by toggle switch in overhead control console.

**Swing brake** — 360°, foot operated, hydraulic applied disc brake mounted on the speed reducer.

**Travel swing lock** — Standard; two position travel swing lock (pin device) operated from the operator's cab.

**Counterweight** — Bolted to upperstructure frame. 7,250 lb. (3 289 kg) cwt. on machines with two hoist drums; 8,100 lb. (3 674 kg) cwt. on one drum machines.

### ■ Hydraulic System

**Main pump** — 2-section gear type pump. Combined pump capacity 68 gpm (257.4 lpm). Torque converter mounted pump powered by engine through a pump disconnect. Pump disconnect is engaged/disengaged from carrier. Section one operates winch circuit @ max. pressure of 3,500 p.s.i. (246 kg/cm<sup>2</sup>). Section two operates boomhoist and telescope circuits @ max. pressure of 3,000 p.s.i. (211 kg/cm<sup>2</sup>).

**Swing / outrigger / steering pump** — Single gear-type pump, 18 gpm (68.13 lpm) maximum. Torque converter mounted

pump powered by engine. Pump operates at 2,500 p.s.i. (175 kg/cm<sup>2</sup>).

The three pump hydraulic circuit allows simultaneous operation of the three main crane functions (winch, boom hoist, swing) without any function interference.

**Reservoir** — 110 gallon (416.39 L) capacity. One diffuser for deaeration.

**Filtration** — One 6-micron filter located inside hydraulic reservoir. Accessible for easy replacement.

**Control valves** — Five separate pilot operated control valves allow simultaneous operation of all crane functions.

### ■ Load Hoist System

**Standard** — 2M main winch with two-speed motor and automatic brake; power up/down mode of operation. Bi-directional piston-type hydraulic motor, driven through a planetary reduction unit for positive control under all load conditions.

*Optional* — Model 1M main winch with one-speed motor and automatic brake, power up/down mode of operation.

*Optional* — Model 1M auxiliary winch with one-speed motor and automatic brake, power up/down mode of operation.

*Optional* — Model 2M auxiliary winch with two-speed motor and automatic brake, power up/down mode of operation.

**Line pulls and speeds** — Maximum line pull 10,360 lbs. (4 699 kg) and maximum line speed of 390 f.p.m. (118.87 m/min) on standard 10-5/8" (0.27 m) root diameter grooved drum.

### ■ Additional Equipment - Standard

Fire extinguisher, seat belt, horn, dome light, mirrors, tilt and locking steering wheel, electric windshield wiper/washer, defroster fan, backup alarm, audible swing alarm, cab-mounted work lights, and rotation resistant wire rope.

### ■ Additional Upperstructure Equipment - *Optional*

360° swing lock (meets New York City requirements), diesel or hydraulic heater, electronic drum rotation indicators, winch function lockout, 30-ton (27.22 metric ton) hook block, 8-1/2-ton (7.71 metric ton) hook ball and swivel, rear steer indicator, engine monitoring system, tachometer, top hatch window wiper, amber rotating beacon, boom floodlight, lifting lugs (upper and lower) and drum cable follower.

# Carrier

## ■ Type

9' 5" (2.87 m) wide, 150" (3.81 m) wheel-base.

4 x 4 x 4 — (4-wheel steer, 4-wheel drive)  
**Standard** — For rough terrain with limited turning area.

4 x 4 x 4 — (4-wheel steer, 4-wheel drive)  
**Optional** — Front axle with no-spin differential; for rough terrain with limited turning area and poor traction.

**Frame** — 100,000 p.s.i. (689.5 MPa) steel, double walled construction with integral 100,000 p.s.i. (689.5 MPa) steel outrigger boxes.

## ■ Axles

**Front-** Standard; heavy duty planetary drive/steer type.

**Rear-** Standard; heavy duty planetary drive/steer type.

**Front-** *Optional*; heavy duty no-spin differential, planetary drive/steer type.

## ■ Suspension

**Front axle** - Rigid mounted to frame.

**Rear axle** - Pin-mounted on welded steel box cradle. Automatic hydraulic rear axle oscillation lock-out engages when upper-structure rotates past 2-1/2° of centerline.

## ■ Tires

### Front and Rear

**Standard** — 20.5 x 25 (24-PR) Earthmover type.

**Optional** — 23.5 x 25 (20-PR) Earthmover type.

## ■ Brakes

**Service** — Air over hydraulic, disc type brakes at each wheel end.

**Parking/emergency** — Disc caliper type spring applied, air released, fade resistant; cab controlled, mounted on front axle.

## ■ Steering

Hydraulic two wheel, four wheel and "crab" steering: controlled from steering wheel.

## ■ Transmission

Clark three-speed two range power shift transmission. Six speeds available forward and reverse. Front axle disconnect for two or four-wheel drive.

## ■ Outriggers

Three position (fully extended, intermediate and fully retracted) operation capability. Four hydraulic, telescoping beam and jack outriggers. Vertical jack cylinders equipped with integral holding valve.

Beams extend to 20' 0" (6.10 m) center-line-to-centerline and retract to within 9' 5" (2.87 m) overall width. Equipped with stowable, lightweight 22" (0.56 m) octagonal aluminum floats. Controls and sight level bubble located in upperstructure cab.

Confined Area Lift Capacities (CALC) System - Outrigger may be extended to an intermediate position (half extended) for working in confined areas. Extend position levers located on outrigger boxes allow the outrigger beams to be fully extended or limits them to half extended length based on the selected position.

## ■ Additional Equipment - Standard

Cab steps, front, side, and rear carrier steps, electronic controlled front axle disconnect, skid resistant finish on carrier deck, front storage, fenders, pontoon storage, full travel lighting package, throttle lock, and hour meter.

## ■ Additional Equipment - Optional

No-spin differential on front axle, front and rear towing shackles, propane fired engine block heater, ether injection package, air dryer, spare tires and rims, front and rear mounted pintle hooks, outrigger cover package, emergency steering system, and carrier mounted winch, and 24 volt start.

## Travel speeds and gradeability

Engine	Tires	Maximum Speed		*Gradeability at stall	Maximum tractive effort at stall		Gradeability at 1.0 mph (1.61 km/h)	Maximum tractive effort at 1.0 mph (1.61 km/h)	
		mph	km/h		pounds	kg		pounds	kg
Cummins 6BT 5.9	20.5 X 25	21.9	35.24	89.0%	40,396	18 324	50.6%	27,807	12 613
	23.5 X 25	22.8	36.69	78.9%	37,712	17 106	46.3%	25,960	11 775

Engine	Cummins 6BT 5.9
Cylinders - cycle	6 - 4
Bore	4.02" (102.1 mm)
Stroke	4.72" (119.9 mm)
Displacement	359 cu. in. (5 884 cm <sup>3</sup> )
Maximum brake hp	152 @ 2500 rpm
Peak torque	400 ft. lbs. (542 J)
Electric system	12 volt
Fuel capacity	75 gallons (284 L)
Alternator	130 amps
Crankcase capacity	17.3 qts. (16.4 L)

**Axle loads**

Base machine with standard 28' 9" — 70' 3" (8.76 m - 21.41 m) three-section boom, 2M main winch with 2-speed hoisting and power up/down, 400' (121.92 m) 5/8" (16 mm) wire rope, 4x4x4 carrier with Cummins 6BT 5.9 engine, 20.5 X 25.0 tires, full fuel and counterweight.	G.V.W.①		Upper facing front				Upper facing rear			
			Front axle		Rear axle		Front axle		Rear axle	
		lbs.	kg	lbs.	kg	lbs.	kg	lbs.	kg	lbs.
	52,066	23 617	22,341	10 134	29,725	13 483	17,626	7 995	34,440	15 622
28' 9" - 91' (8.76 - 27.74 m) 4-section boom	1,359	616	2,190	993	-831	-377	-1,103	-500	2,462	1 116
1M main winch with 400' (121.92 m) wire rope	-19	-8	4	2	-23	-10	-19	-9	0	0
1M auxiliary winch with 350' (106.68 m) wire rope	-46	-29	8	4	-73	-33	-60	-27	-5	-2
2M auxiliary winch with 350' (106.68 m) wire rope	-29	-13	2	1	-31	-14	-25	-11	-4	-2
23.5 x 25.0 tires	328	149	160	73	168	76	160	73	168	76
Jack Cylinder Covers	135	61	63	28	72	33	63	28	72	33
Tow winch	686	311	923	419	-237	-108	923	419	-237	-108
Winch roller - front	67	30	-1	-1	68	31	55	25	12	5
Winch roller - rear	67	30	-13	-6	80	36	66	29	1	1
360° swing lock	47	21	16	7	31	14	22	10	25	11
Emergency steering	136	62	0	0	136	62	108	49	28	13
Diesel heater with tank	70	32	19	9	51	23	37	17	33	15
Hydraulic heater	110	50	22	10	88	40	66	30	44	20
Hookblock at boom head	620	281	1,571	712	-951	-431	-1,075	-488	1,695	769
Headache ball at boom head	325	147	836	379	-511	-232	-576	-261	901	408
Auxiliary lifting sheave	121	55	315	143	-194	-88	-218	-99	339	154
25' (7.62 m) fixed lattice fly stowed	652	296	936	425	-284	-129	-414	-188	1,066	484
25' (7.62 m) offsettable lattice fly stowed	1,094	496	1,631	740	-537	-244	-756	-343	1,850	839
25' - 43' (7.62 - 13.1 m) offsettable lattice fly stowed	1,639	743	2,400	1 088	-761	-345	-1,089	-494	2,728	1 237

① Adjust gross vehicle weight & axle loading according to component weight.

Note: All weights are ± 3%

Tire	Max. Axle Load @ 20 mph (32.7 km/hr)
20.5 x 25 (24-PR)	31,000 lbs. (14 062 kg)
23.5 x 25 (20-PR)	31,000 lbs. (14 062 kg)