

2-WHEEL DRIVE

- * Capacity on outriggers...18,000 lbs.
- * Pick and carry capacity up to...11,700 lbs.
- * Height...7' 3"
- * Width...6' 6"
- * Sheave height...up to 46'
- * Horizontal Reach...up to 40'
- * Tight turning radius
- * 2-Wheel drive standard
- * 4-Wheel steer standard
- * 4-Wheel drive optional
- * Powershift transmission
- * Fully hydraulic controls for smooth precise operations
- * Independent outrigger controls

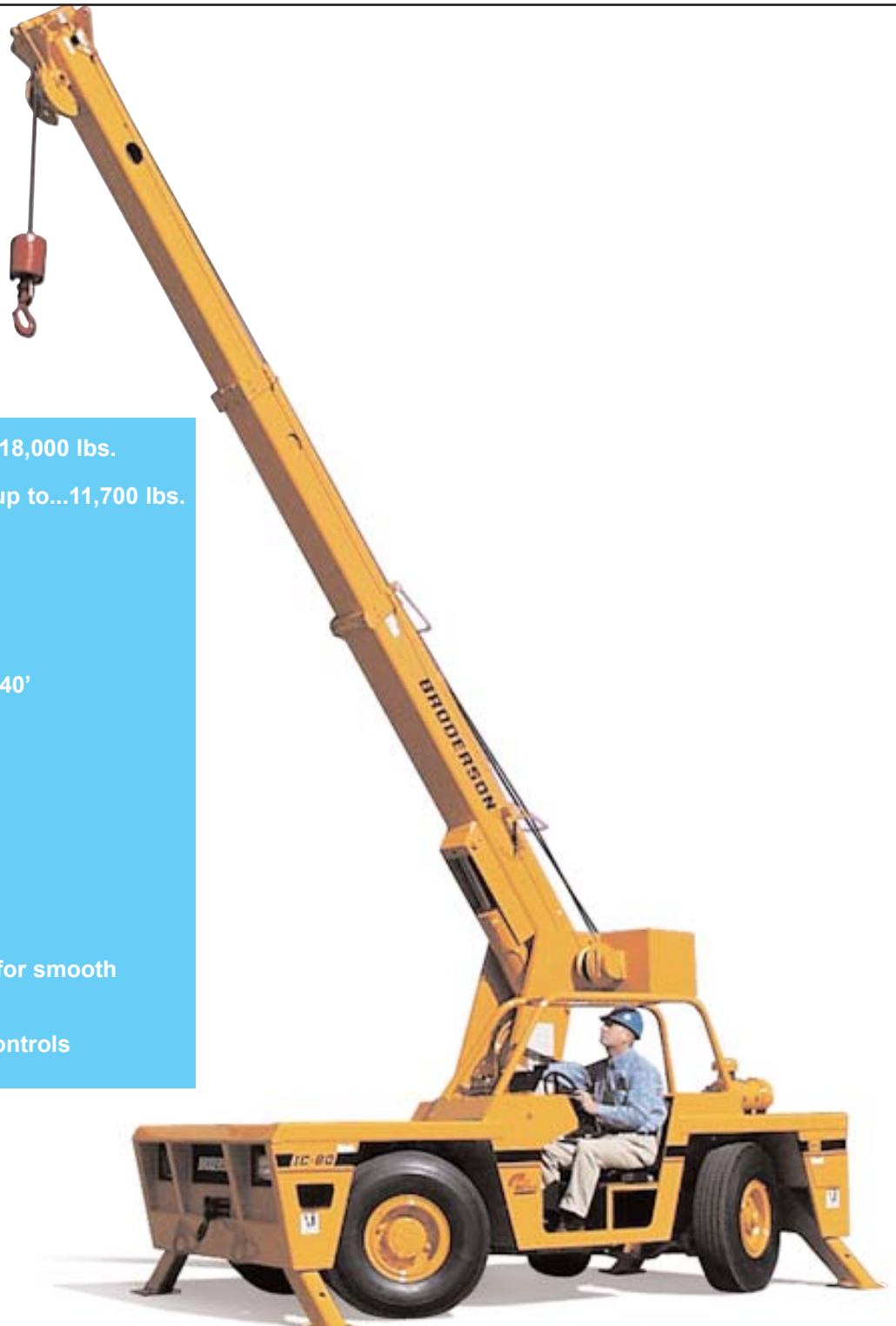

BMC[®] BRODERSON[®]
Manufacturing Corp.

P.O. Box 14770, Lenexa, KS 66285-4770
14741 West 106th St. • Lenexa, KS 66215-2015
(913) 888-0606 • FAX (913) 888-8431
Website: bmccranes.com

Tech Spec

4-Wheel Drive 4-Wheel Steer

- * Capacity on outriggers...18,000 lbs.
- * Pick and carry capacity up to...11,700 lbs.
- * Height...7' 3"
- * Width...6' 6"
- * Sheave height...up to 46'
- * Horizontal Reach...up to 40'
- * Tight turning radius...11' 8"
- * 4-Speed synchromesh transmission
- * Independent outrigger controls
- * 4-Wheel hydraulic internal wet disc brakes



IC-80-1F

IC-80-1F 8'-2" - 20'-2" BOOM

CAPACITIES APPLY TO OPERATION ON FIRM LEVEL SURFACE						
LOAD RADIUS FEET	MAIN BOOM OR EXTENSION CAPACITIES IN POUNDS					
	360° ROTATION		OVER FRONT			
	ON RUBBER	ON OUTRIGGERS	ON RUBBER	ON OUTRIGGERS		
MAIN BOOM	5	9600	17000	11700	18000	
	6	7900	14500	10400	14500	
	8	5750	10250	8400	10250	
	10	4150	7700	6300	7700	
	12	3100	6550	4650	6550	
	14	2425	5550	3650	5550	
	16	1975	4650	3000	4650	
	18	1625	3950	2500	4150	
	20	1400	3550	2150	3800	
	10' BOOM EXT.	22	1275	3000	1900	3000
24		1075	2750	1650	2800	
26		925	2450	1425	2600	
28		775	2150	1250	2400	
30		675	1950	1100	2250	
10-FOOT BOOM EXTENSION - STRAIGHT OR OFFSET						
MAIN BOOM ANGLE						
ANGLE	0°	30°	45°	60°	70°	
† 0°	2250	2600	3200	5000	7000	
† 15°	---	2400	2700	3500	4200	
† 30°	---	2250	2500	3000	3300	

* USE 0° FOR STRAIGHT BOOM EXTENSION.
 † USE 0°, 15° OR 30° FOR OFFSET BOOM EXTENSION.
 BOOM EXTENSION LOADS MUST NOT EXCEED MAIN BOOM CAPACITY.

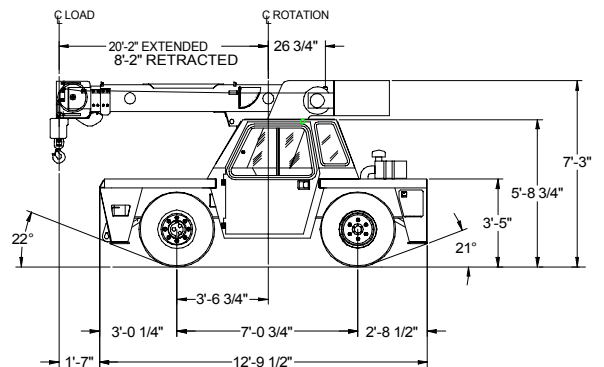
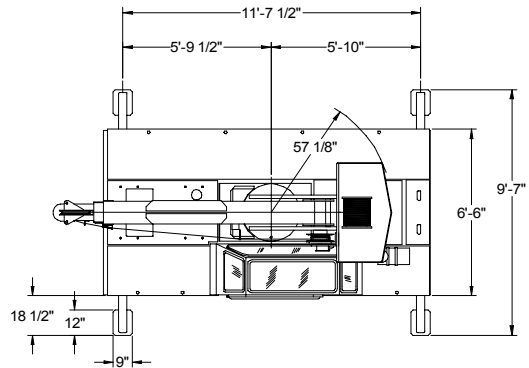
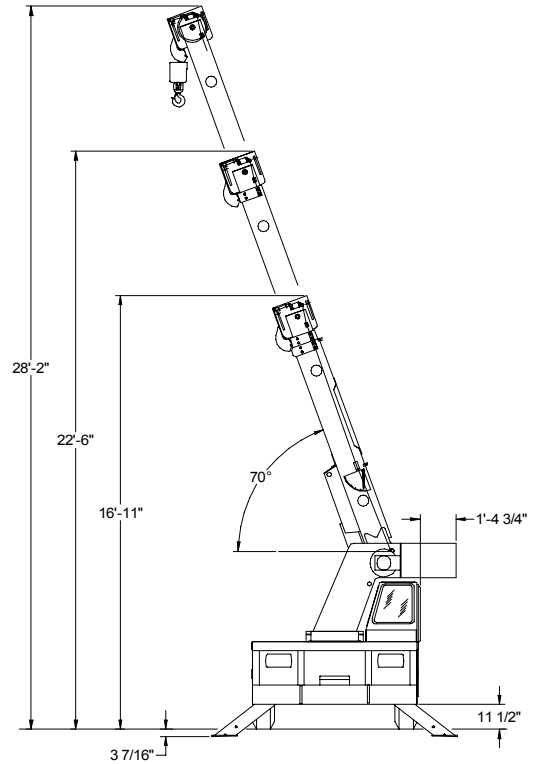
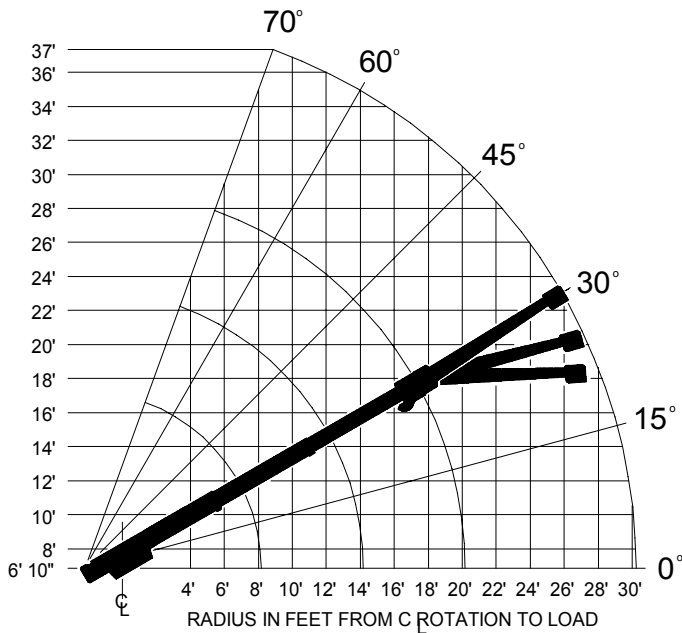
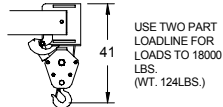
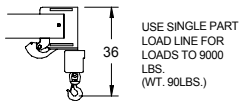

IC-80-2F

IC-80-2F 9'-6" - 24'-0" BOOM

CAPACITIES APPLY TO OPERATION ON FIRM LEVEL SURFACE						
LOAD RADIUS FEET	MAIN BOOM OR EXTENSION CAPACITIES IN POUNDS					
	360° ROTATION		OVER FRONT			
	ON RUBBER	ON OUTRIGGERS	ON RUBBER	ON OUTRIGGERS		
MAIN BOOM	5	9500	17000	11600	18000	
	6	7800	14500	10200	14500	
	8	5500	10250	8250	10250	
	10	3900	7700	6200	7700	
	12	2900	6550	4550	6550	
	14	2300	5550	3550	5550	
	16	1850	4550	2850	4550	
	18	1550	3950	2400	4050	
	20	1300	3250	2050	3650	
	22	1100	2875	1750	3300	
24	925	2475	1550	3100		
10' BOOM EXT.	26	850	2250	1350	2750	
	28	700	2000	1175	2500	
	30	600	1775	1025	2300	
	32	500	1625	900	2100	
	34	425	1400	800	1950	
	10-FOOT BOOM EXTENSION - STRAIGHT OR OFFSET					
	MAIN BOOM ANGLE					
	ANGLE	0°	30°	45°	60°	70°
	* † 0°	2250	2600	3200	5000	7000
	† 15°	—	2400	2700	3500	4200
† 30°	—	2250	2500	3000	3300	

* USE 0° FOR STRAIGHT BOOM EXTENSION.
 † USE 0°, 15° OR 30° FOR OFFSET BOOM EXTENSION.
 BOOM EXTENSION LOADS MUST NOT EXCEED MAIN BOOM CAPACITY.

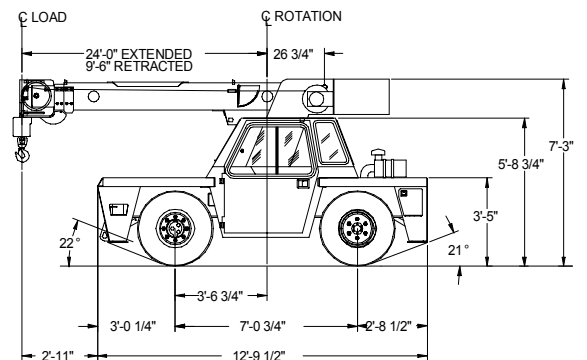
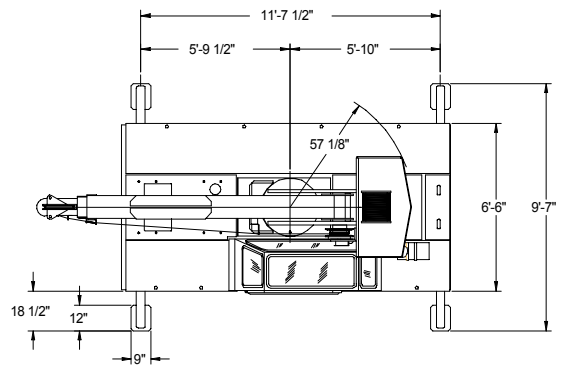
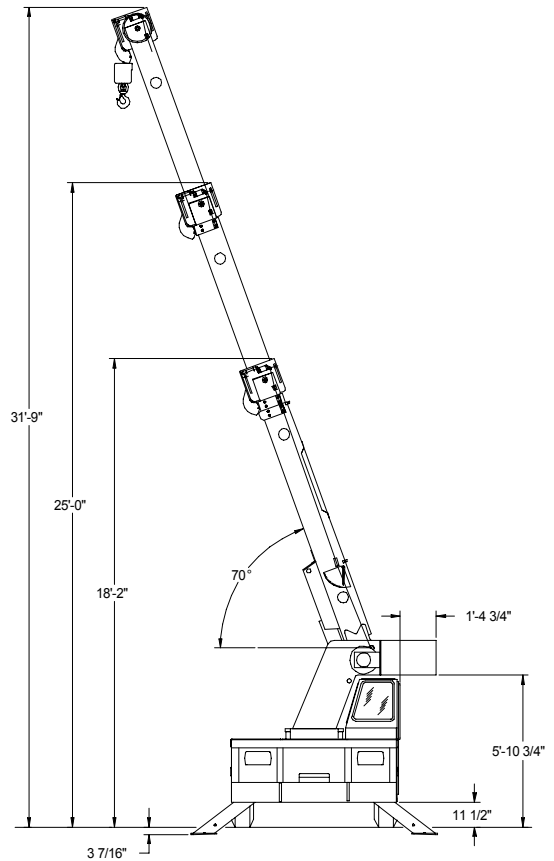
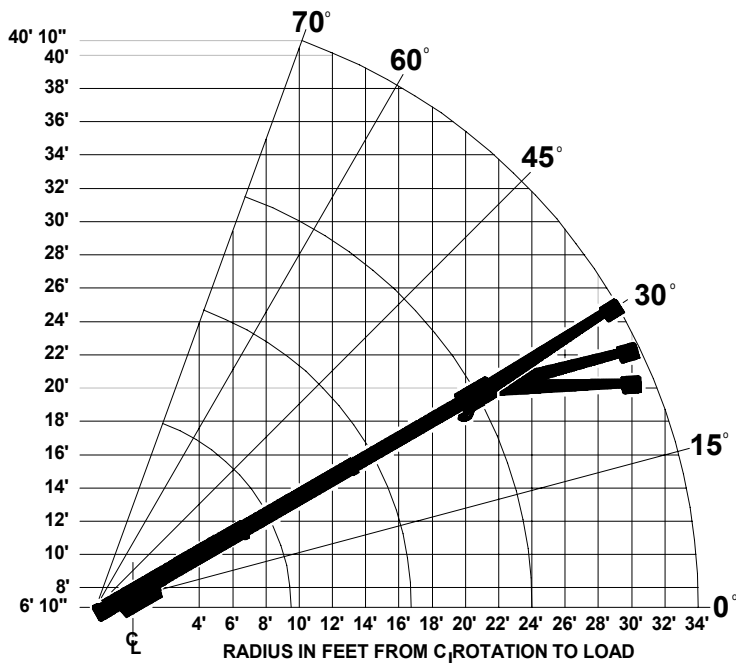
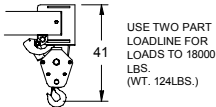
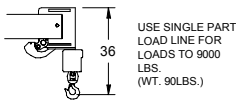

IC-80-3F

IC-80-3F 11'-6" - 30'-0" BOOM

CAPACITIES APPLY TO OPERATION ON FIRM LEVEL SURFACE					
LOAD RADIUS FEET	MAIN BOOM OR EXTENSION CAPACITIES IN POUNDS				
	360° ROTATION		OVER FRONT		
	ON RUBBER	ON OUTRIGGERS	ON RUBBER	ON OUTRIGGERS	
5	9400	17000	11400	18000	
6	7550	14000	10000	14000	
8	5250	10000	8100	10000	
10	3600	7700	6100	7700	
12	2650	6100	4450	6100	
14	2050	5200	3400	5200	
16	1600	4400	2700	4400	
18	1250	3650	2200	3900	
20	1050	3050	1800	3400	
22	850	2650	1550	3050	
24	750	2300	1350	2800	
26	650	2050	1150	2550	
28	550	1850	1000	2350	
30	450	1650	900	2150	
32	350	1550	750	1950	
34	250	1400	650	1800	
36	200	1250	550	1650	
38	150	1100	450	1500	
40	100	1000	400	1400	
10-FOOT BOOM EXTENSION - STRAIGHT OR OFFSET					
MAIN BOOM ANGLE					
ANGLE	0°	30°	45°	60°	70°
* † 0°	2250	2600	3200	5000	7000
† 15°	—	2400	2700	3500	4200
† 30°	—	2250	2500	3000	3300

* USE 0° FOR STRAIGHT BOOM EXTENSION.

† USE 0°, 15° OR 30° FOR OFFSET BOOM EXTENSION.

BOOM EXTENSION LOADS MUST NOT EXCEED MAIN BOOM CAPACITY.

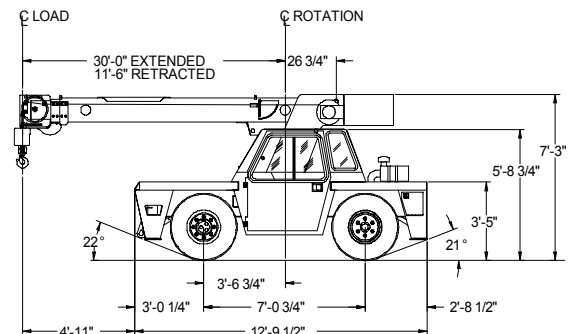
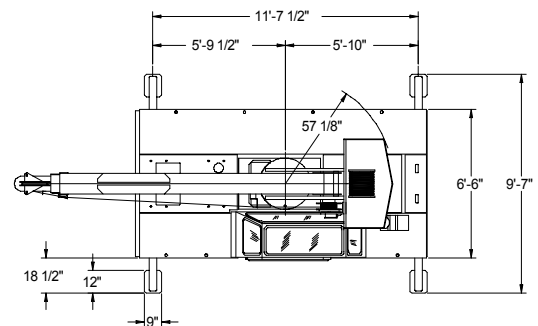
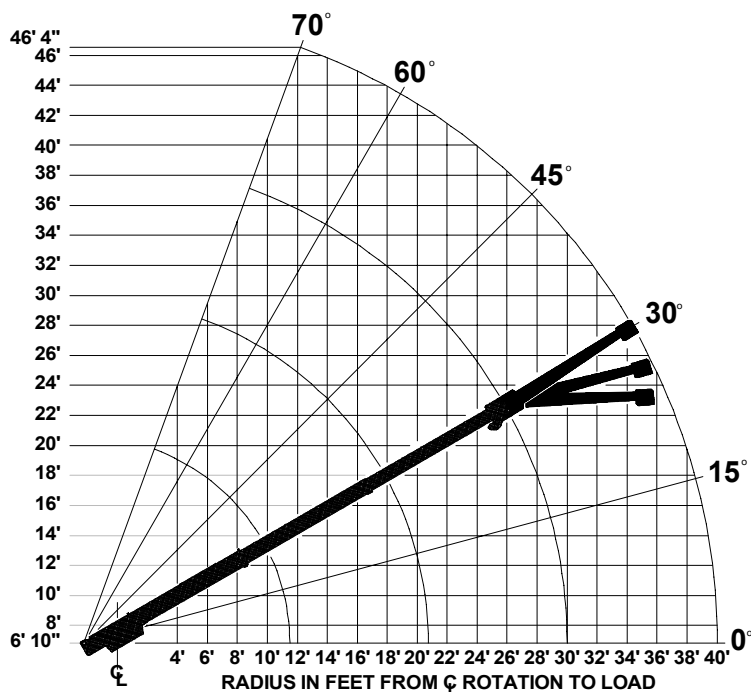
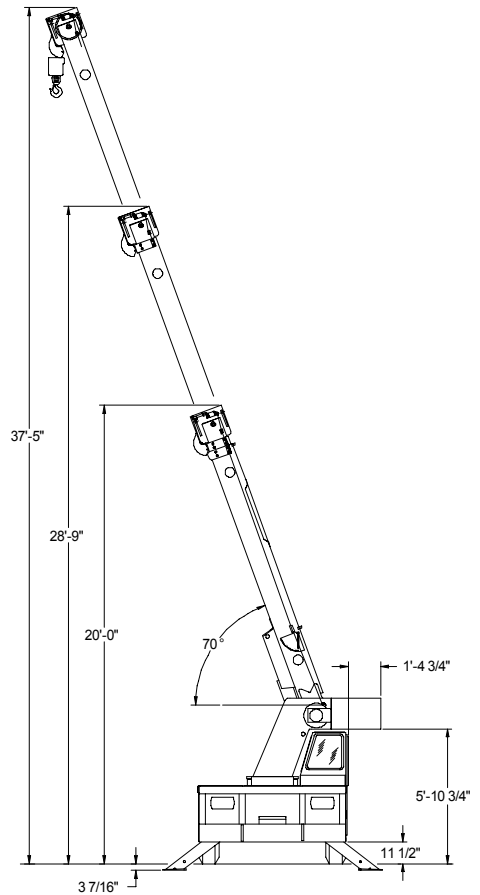
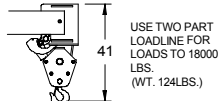
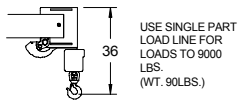

IC-80-F

GENERAL:

Weight:	IC-80-1F	IC-80-2F	IC-80-3F
4-Wheel Steer	15,730 lbs.	15,930 lbs.	16,230 lbs.
4-Wheel Drive	16,430 lbs.	16,630 lbs.	16,930 lbs.

Boom Movement:

Rotation	Continuous	Continuous	Continuous
Elevation	0° to 70°	0° to 70°	0° to 70°
Extension	12 ft.	14 ft. 6 in.	18 ft. 6 in.

Boom Speeds:

Rotation	2.0 RPM	2.0 RPM	2.0 RPM
Elevation	10.0 sec.	10.0 sec.	10.0 sec.
Extension	17.0 sec.	21.0 sec.	27.0 sec.

Turning Radius:

	Standard	Optional
(C/L of Outside Steering Wheel)	4-Wheel Steer	4-Wheel Drive
	10 ft. 9 in.	11 ft. 8 in.

Aisle Width for 90° Turn:

9 ft. 7 in.	9 ft. 9 in.
-------------	-------------

ENGINE:

	Standard	Optional
Make	GM	Cummins
Model	3.0 EFI*	4B3.9
Type	Gas	Diesel
No. Cyl.	4	4
Displacement	181 CID	239 CID
HP @ Gov. Speed	69	80

Fuel Tank Capacity: 20 Gallons

* Electronic Fuel Injection with Dual Fuel

TRANSMISSION:

2-Wheel Drive:

Powershift transmission with 4-speeds in forward and reverse. Provides powershifts at any engine speed in any gear. All shifting is done with a single lever electrical control mounted on the steering column. Multiple-disc clutch packs operated by solenoid valve provide forward, neutral, reverse & speed selection. Equipped with oil cooler and filter. Torque converter has stall ratio of 2.2:1.

Gradeability 70 percent.

Gear	Forward/Reverse Gear Ratios	Travel Speed	Drawbar Pull
First	5.72:1	4 MPH	10,900 lbs.
Second	3.23:1	7 MPH	6,090 lbs.
Third	1.77:1	12 MPH	3,270 lbs.
Fourth	1.00:1	22 MPH	1,780 lbs.

TRANSMISSION: (Cont'd)

4-Wheel Drive:

Remote mounted synchromesh 4-speed. Forward, neutral and reverse control mounted on steering column. 4-speed control has side lever & push button knob for electric declutching. Can be shifted while in motion. Equipped with oil cooler and filter. Torque converter has stall ratio of 2.2:1.

Gradeability 72 percent.

Gear	Forward/Reverse Gear Ratios	Travel Speed	Drawbar Pull
First	4.29:1	5 MPH	11,500 lbs.
Second	2.66:1	8 MPH	7,070 lbs.
Third	1.41:1	15 MPH	3,670 lbs.
Fourth	0.77:1	27 MPH	1,930 lbs.

AXLES:

Front:

Planetary drive/steer axle with 11.98:1 ratio. Differential is "Limited Slip." Axle mounted rigidly to frame.

Rear:

2-Wheel Drive:

Axle with 1-1/2 degree oscillation in either direction.

4-Wheel Drive:

Planetary drive/steer axle with 11.98:1 ratio. Differential is "Limited Slip." 1-1/2 degree oscillation in either direction.

STEERING:

Hydraulic steering unit with two cylinders attached to each axle. Rear axle is the primary steer. An electric switch in the operator's compartment is used to select rear-wheel steering or four-wheel round steering.

BRAKES:

	2-Wheel Drive	4-Wheel Drive
Front	Internal wet disc brakes	Internal wet disc brakes
Rear	Drum type	Internal wet disc brakes
Parking	Disc type	Disc type

TIRES:

2-Wheel Drive 10.00 x 15, load range J radial, highway type tread.

4-Wheel Drive 10.00 X 15, mining & industrial, 16 ply rating.

CHASSIS:

Cargo Deck:

64 square feet of deck area.* 14,000 lbs. capacity on deck when load is centered over or between axles.** A storage box is located in front cargo deck. Steps located on front corners.

* 54 Square feet with Cummins engine.

**14,000 pounds allowed at creep speed of 200 feet in 30 minutes.

Outriggers:

Four hydraulic outriggers of box beam construction with direct-connected holding valves. Independent controls for each outrigger. Each cylinder equipped with direct-connected holding valves. Outrigger pad dimension 9" x 12".

Accessory Storage Box:

Storage box located in front cargo deck.

Lifting Rings

Lifting rings at each corner of cargo deck so sling can be attached for lifting crane.

OPERATOR COMPARTMENT:

Operator's control station provides one-position access to all operating functions. Includes adjustable operator's seat, retracting seat belt, fire extinguisher and bubble level.

ELECTRICAL:

12 Volt System

Instrument Package:

Fuel, ammeter, oil pressure, water temperature, transmission oil temperature gauges & hourmeter. Also included are warning lights for low transmission pressure, turn signal, high beams, hazard lights, parking brake & 4-wheel drive.

Lighting Package:

One pair headlights with Hi and Low beams, back-up lights, integral tail, brake, front and rear turn signals & emergency flasher switch at operator's station. 12V horn actuated by button on shifting control.

ELECTRICAL: (Cont'd)

Back-Up Alarm:

Provides pulsating sound from 97 dB alarm when transmission is in reverse. Conforms to SAE J994b.

Outrigger Alarm System

Two-tone alarm is activated when "outrigger down" controls are operated.

HYDRAULIC SYSTEM:

Tandem pump, direct-driven by engine crankshaft, rated at 17 & 32 GPM at rated RPM. Hydraulic oil tank capacity of 22 gallons.

BOOM ASSEMBLY:

Three-section boom assembly equipped with bearing pads, double-acting hydraulic cylinders with direct-connected holding valves & boom angle indicator on each side of boom.

Boom Rotation:

Heavy-duty ball bearing rotation gear with external teeth. Rotation is powered by hydraulic motor and worm gear drive.

Boom Hoist:

Turret mounted planetary gear hoist hydraulically powered with a bare drum line pull of 10,000 lbs. at a line speed of 110 FPM. Includes downhaul weight, swivel hook & sheave block for 2-part line and 125 ft. of 9/16" hoist rope.

Anti-Two-Block Device:

Prevents damage to hoist rope and/or crane components from pulling load hook against tip.

Sheave Block, Two-Part:

Single sheave block for 2-part line requirements.

Rated Capacity Limiter:

Warns operator of impending overload with audible and visual signals. Prevents overload by stopping boom functions that cause overloads.

IC-80-F

Listed below are brief descriptions of each option available for the IC-80-F Industrial Cranes. Consult the IC-80-F Engineering Spec for additional information on each option.

MODELS:

- IC-80-1F** Industrial Crane with 8'2"-20'2" Boom
- IC-80-2F** Industrial Crane with 9'6"-24' Boom
- IC-80-3F** Industrial Crane with 11'6"-30' Boom

ENGINE:

- Diesel Engine**
Cummins - 4B3.9
- Spark Arrester Muffler**
Installed in addition to std. muffler.
- Catalytic Converter**
Reduces engine emissions.
- Engine Heater**
Engine coolant heater installed to circulate warm water through engine. Plugs into 120 volt AC.
- Ether Injection System**
Ether starting aid controlled by switch in operator compartment and injects ether directly into intake manifold.
- Engine Shut Down Gauges**
Shuts engine off when high water temperature or low engine oil pressure occurs. (Diesel Only)

AXLE & STEERING OPTIONS:

- 4-Wheel Steer & 4-Wheel Drive**

TIRE OPTIONS:

- Mining & Industrial Tires**
 - 10.00 x 15, 16-Ply Rating
 - 10.00 x 15, Non Marking
- Solid Rubber Tires:**
 - 8.25 x 15
 - 8.25 x 15 Non-Marking
- Foam Filling of Tires**
- Spare Tire & Wheel**
 - Highway Tread, 10.00 x 15
 - Mining & Industrial, 10.00 x 15
 - Mining & Industrial, Non Marking

CHASSIS OPTIONS:

- Auxiliary Winch**
Mounted behind front bumper, hydraulically driven with control in operator's console.

CHASSIS OPTIONS: (Cont'd)

- Pintle Hook:**
 - Pintle Hook, Rear**
 - Pintle Hook, Front**
- Headlight and Taillight Grilles**
Welded steel protective grilles for headlights and taillights.
- Rear Work Light Grilles**
Protective grilles for worklights.
- Rearview Mirrors**
One mounted on right-hand deck stake & one mounted on left-hand deck stake.

OPERATOR COMPARTMENT OPTIONS:

- Operator Guard**
Tubular steel weldment with heavy expanded steel mesh top section.
- Operator Guard Cover**
Clear vinyl cover which goes over Operator Guard, for inclement weather operations.
- Operator Guard Door**
Hinged door covers operator compartment side opening.
- All-Weather Cab**
Rigid-mounted canopy section & removable hinged door. Includes heater, electric windshield wiper, one sliding glass window in the door & one in the right side of canopy. Defroster fan & dome light included.
- Cab Heater**
Heater with two-speed fan for units without All Weather Cab.
- Windshield Washer**
Includes reservoir pump and nozzle.
- Floor Mat**
Vinyl mat with foam backing.
- Operator Suspension Seat**
Provides additional operator comfort.
- Noise Reduction Kit**
Includes floor mat, control valve and side panels of foam backed vinyl for noise reduction.
- Air Conditioning**
Air Conditioner with R134 coolant.

ELECTRICAL OPTIONS:

- Strobe Lights**
Yellow strobe light mounted on each side of turret weight box.
- Amber Rotating Beacons**
Amber rotating beacon mounted on each side of turret weight box.
- Boom Work Lights**
One work light mounted to boom to light boom tip and one work light mounted to turret to light ground under boom tip.
- Work Lights-Rear**
Two work lights recessed in rear bumper.

BOOM ATTACHMENTS:

- Boom Extension, 10 Foot**
Boom stowable.
- Boom Extension, 10 Foot, Offsettable**
Same as above item, except the boom extension is offsettable to 3 different positions; 0 degrees (inline), 15 degrees and 30 degrees offset.
- Searcher Hook:**
Nose Mount

Should you, as an end user, require an option or special equipment on your IC-80-F that is not listed on our sales literature, please contact your dealer salesperson or the factory to receive a special quoted price.