

F 300SE

use and maintenance

Edition EXTRA CE 03.12.97

From Serial number *0121*

INDEX

Chapter	I	INTRODUCTION	page 2
	II	SAFETY NORMS	page 3
	III	INSTRUCTIONS FOR CRANE USE	page 5
	IV	IDENTIFICATION OF THE CRANE MODEL	page 6
	V	TECHNICAL DATA	page 7
	VI	CRANE NOMENCLATURE	page 9
	VII	SAFETY AND PROTECTION DEVICES	page 10
	VIII	LIFTING MOMENT LIMITING DEVICE	page 12
	IX	CONTROLS TO STABILIZE THE VEHICLE	page 14
	X	CONTROLS TO OPERATE THE CRANE	page 16
	XI	USE OF IMPLEMENTS	page 19
	XII	MAINTENANCE INSTRUCTIONS	page 20
	XIII	POSSIBLE FAULTS	page 23
	XIV	HYDRAULIC AND ELECTRIC SCHEMATICS	page 24
	XV	OIL AND LUBRICANT CHARACTERISTICS	page 26
	A	INSTRUCTION AND WARNING PLATES	page 27
	B	CAPACITY PLATES	page 30

FASSI CRANE

F 300SE

use and maintenance

This instruction manual describes the FASSI CRANE F300SE.

The fitment must be carried out in accordance with the instructions given by the Manufacturer in the manual for hydraulic crane fitting.

The Manufacturer declines all responsibility and guarantee if the fitting is entrusted to workshops without sufficient technical capability to carry out the work in conformity.

As well as the principal safety norms, this manual contains a description of the crane and the instructions for use and maintenance.

The crane must only be operated by responsible persons, previously instructed and authorized.

THANK YOU FOR SELECTING ONE OF OUR CRANES.

SAFETY NORMS

(!) This symbol draws your attention on the points concerning safety.
It means: **WARNING! BE CAREFUL!**
IT CONCERNS YOUR SAFETY!

!ATTENTION!

READ THIS MANUAL CAREFULLY prior to use of the crane or any maintenance.
A few minutes spent now could save time and labour later. Be sure that the unit has been installed, inspected and tested in accordance with the local legal requirements.

To operate the crane it is necessary to fully understand its working, safety and warranty norms.

Warning plates, as well as instruction and operation plates must be replaced when no longer readable or missing. (See chapters A - B)

Check that protections are in their place and that all safety devices are fitted and active.

Do not run the engine in a indoor area without first making sure there is adequate ventilation. Fit a suitable extension tube to the vehicle exhaust pipe to take the fumes away from the working area.

Stabilize the vehicle by means of the outrigger rams, checking that they rest on a solid base; the plate pressure of the rams is: 650 psi. If in doubt use special larger outrigger base plates (available on request). (See chapter IX)

Level the crane so as it is always operated on a horizontal plane.
Never operate the outriggers when the crane is loaded.

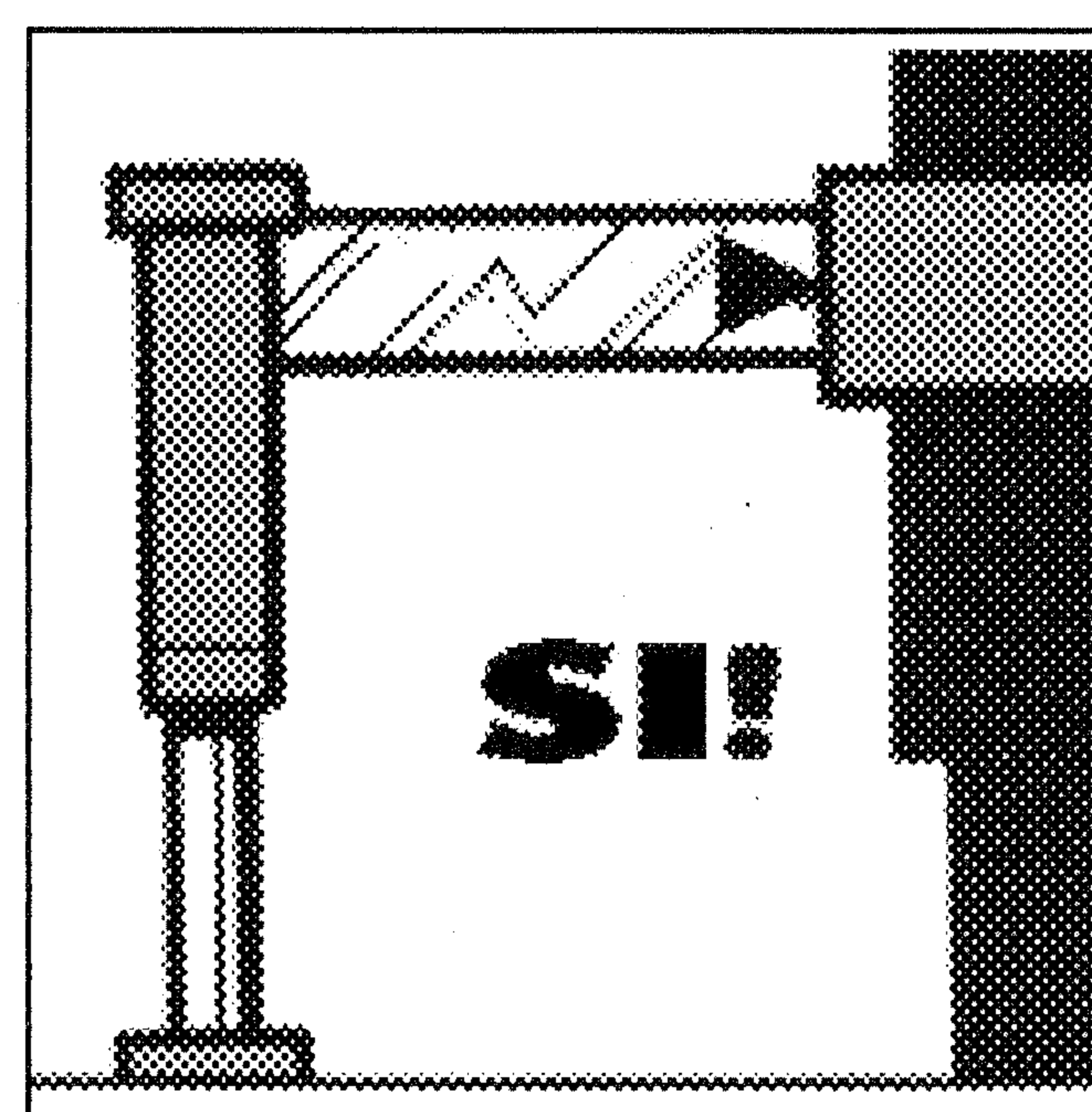
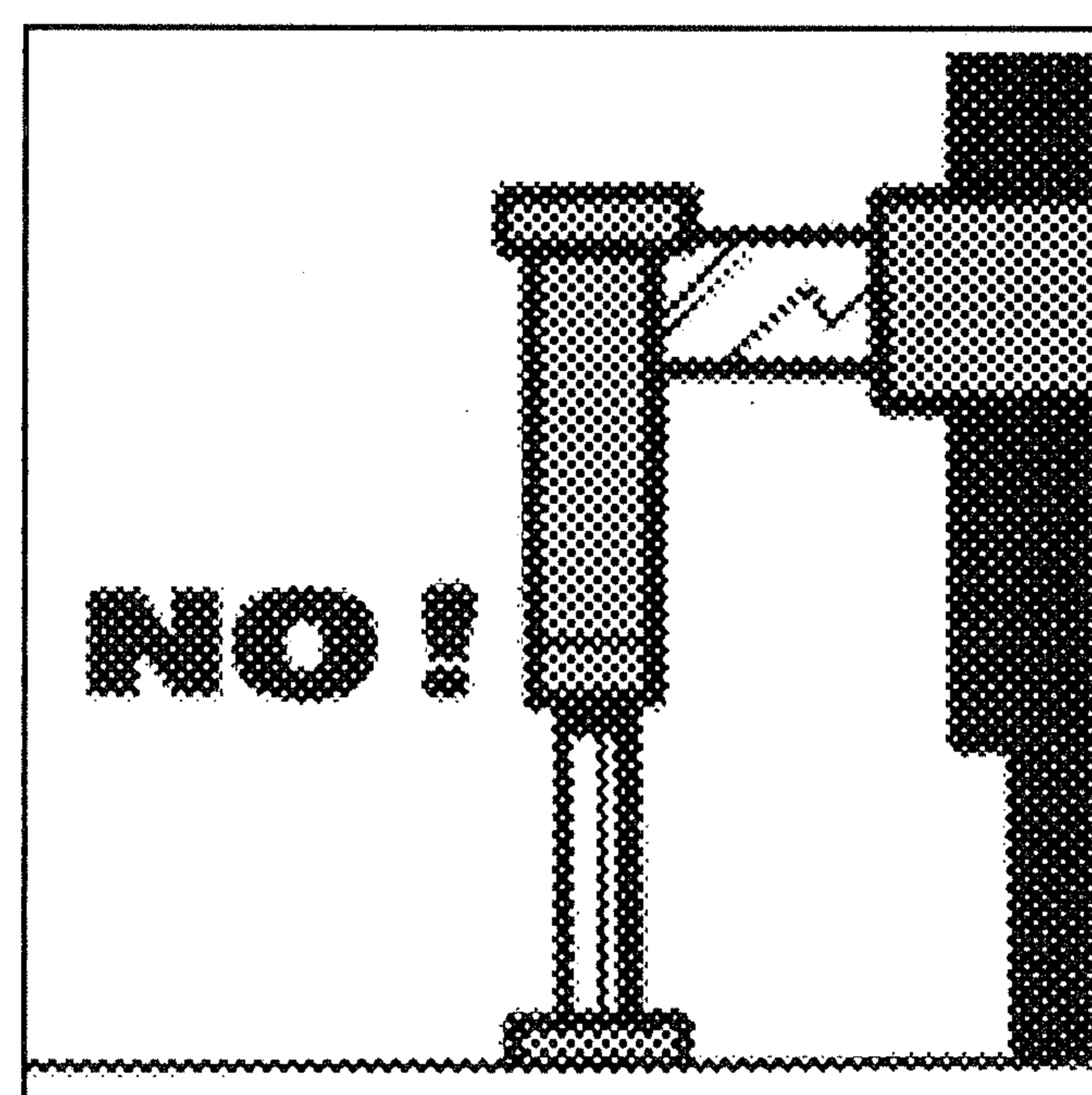
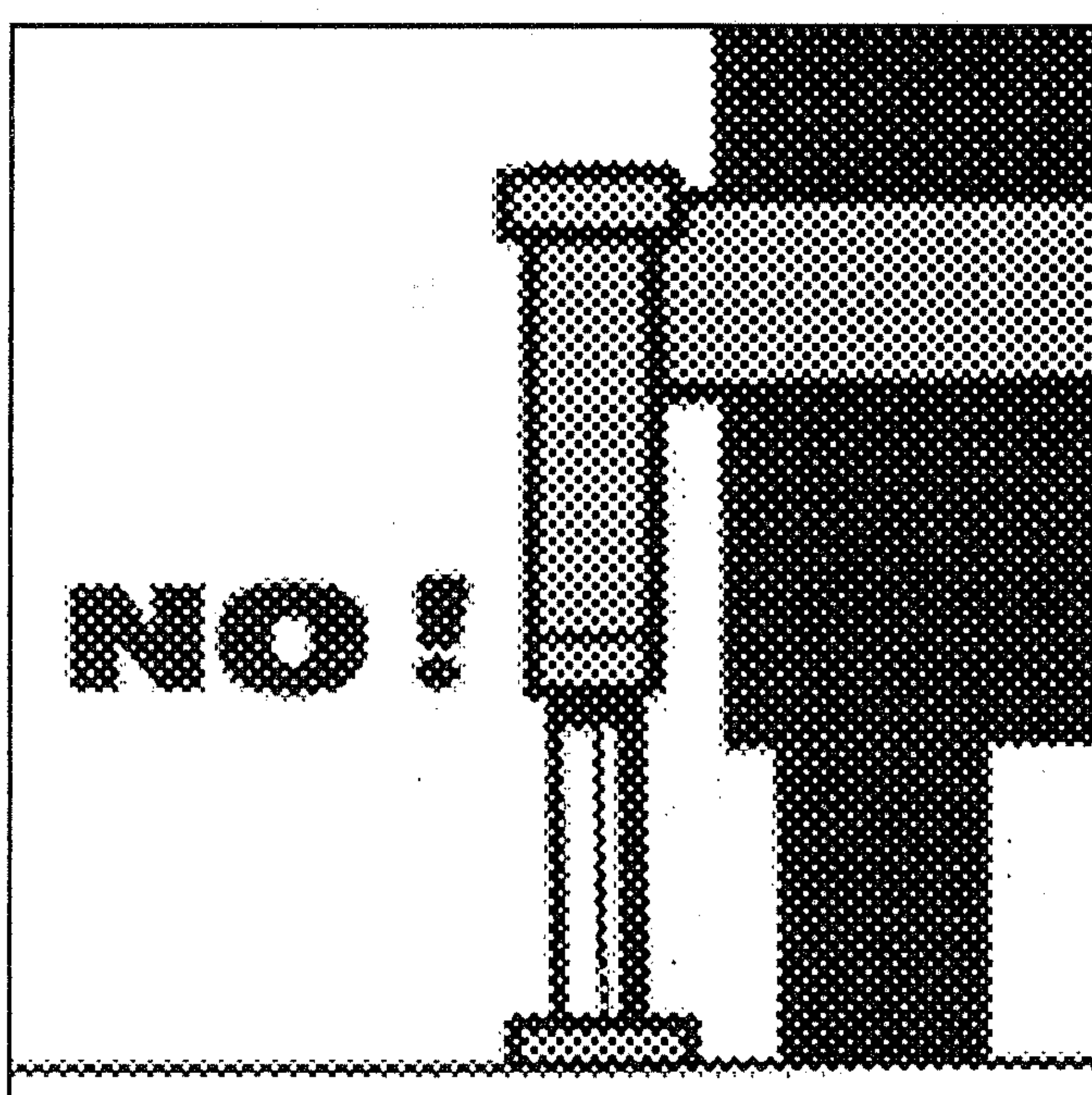
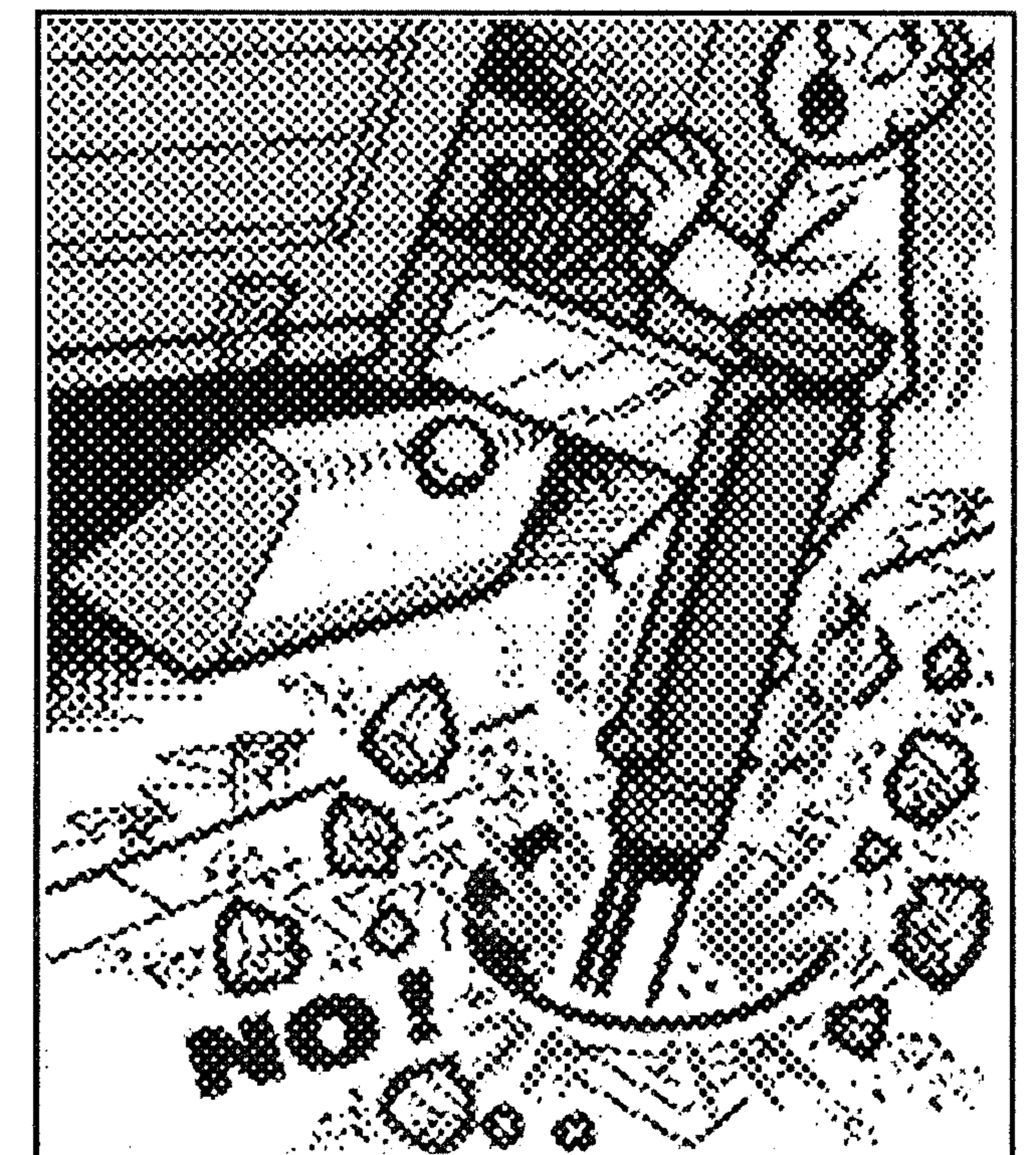

Remember that the stability of the unit (crane-vehicle) is only guaranteed by the maximum lateral extension of the outriggers.

Should visibility be insufficient, make sure that control stations are properly lighted so as to ensure safety while operating control functions and allow reading of the plates.

Before manoeuvring a load check that the working area is adequate and properly lighted for your crane.

Make sure that the lifted load is balanced.

Hook up the load, checking that it does not exceed the capacity indicated on the lifting diagram specific to each load configuration.

It is absolutely prohibited to walk or stop under a suspended load and for unauthorized persons to be within the working area.

Avoid swinging the load above the control station.

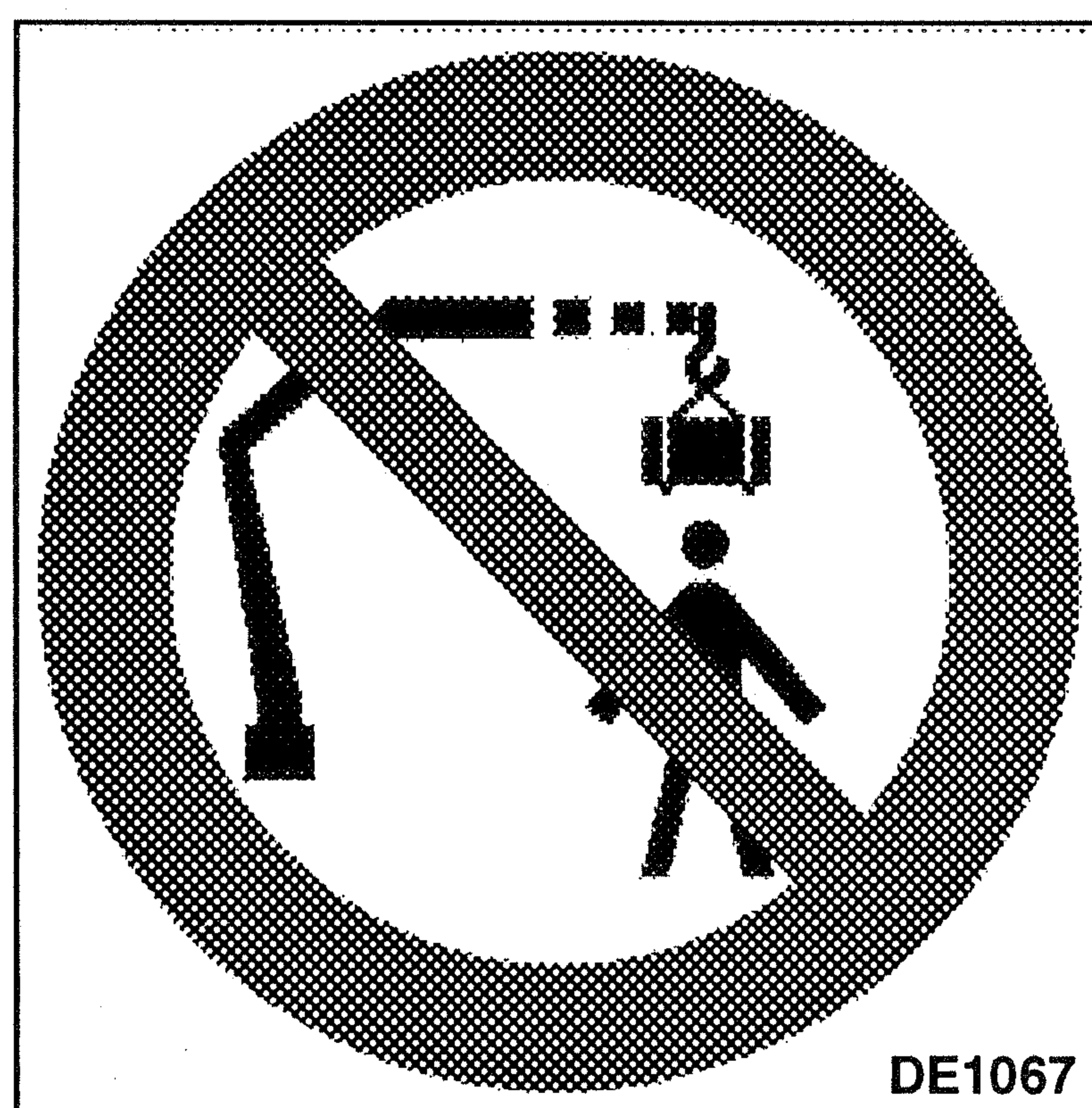

Maintain safe clearances from electrical lines and apparatus. You must allow for boom sway, rock or sag and electrical line and loadline swaying. This lifting device does not provide protection from contact with or proximity to an electrically charged conductor. You must maintain a clearance of at least 10 feet between any part of the crane, loadline or load and any electrical line or apparatus carrying up to 50.000 volts. One foot additional clearance is required for every additional 30.000 volts or less.

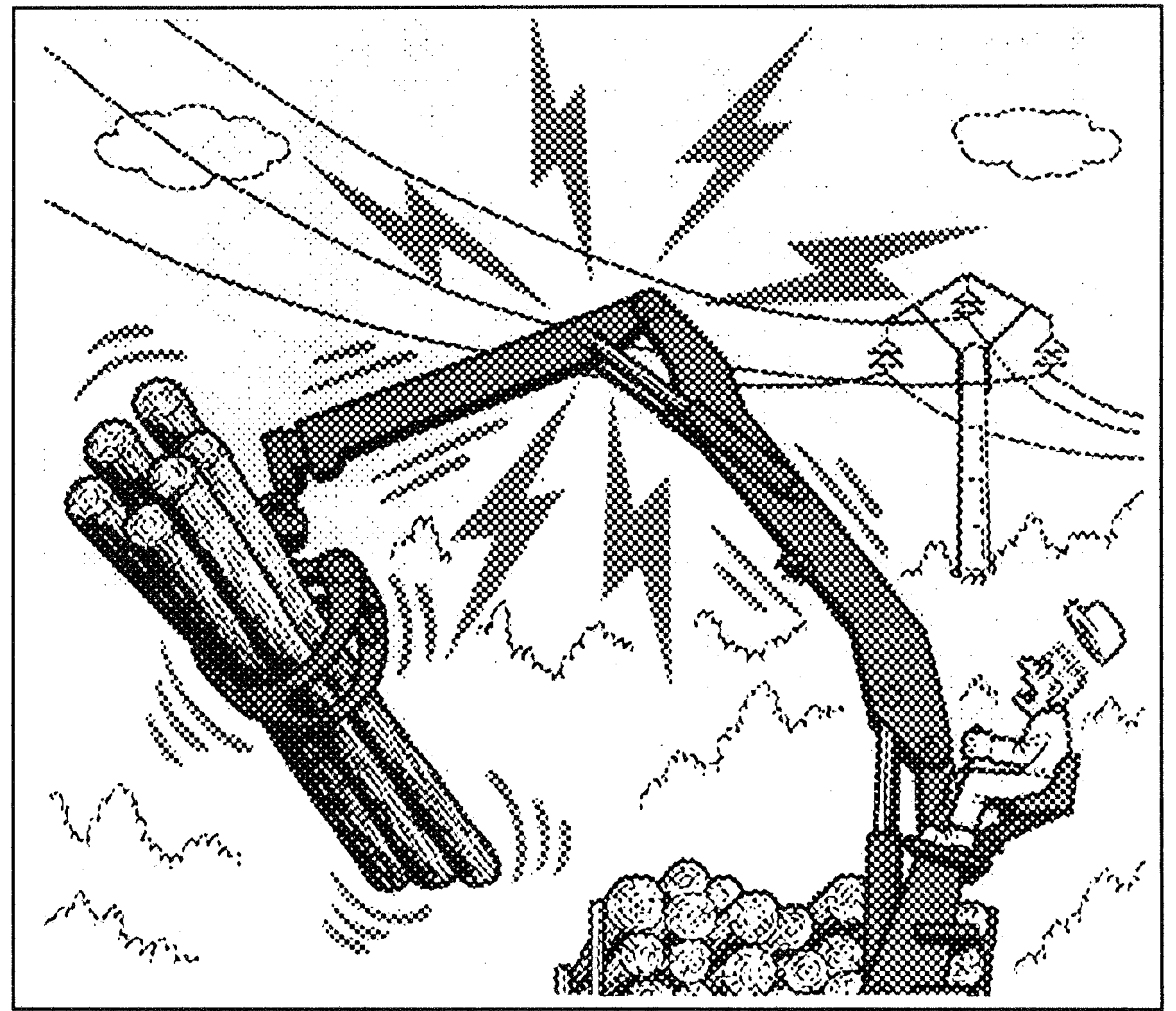

In case of crane with top seat controls, it's necessary to use a ladder and a cat walk to reach the control station, in conformity to the actual norms, with guarantee access security.

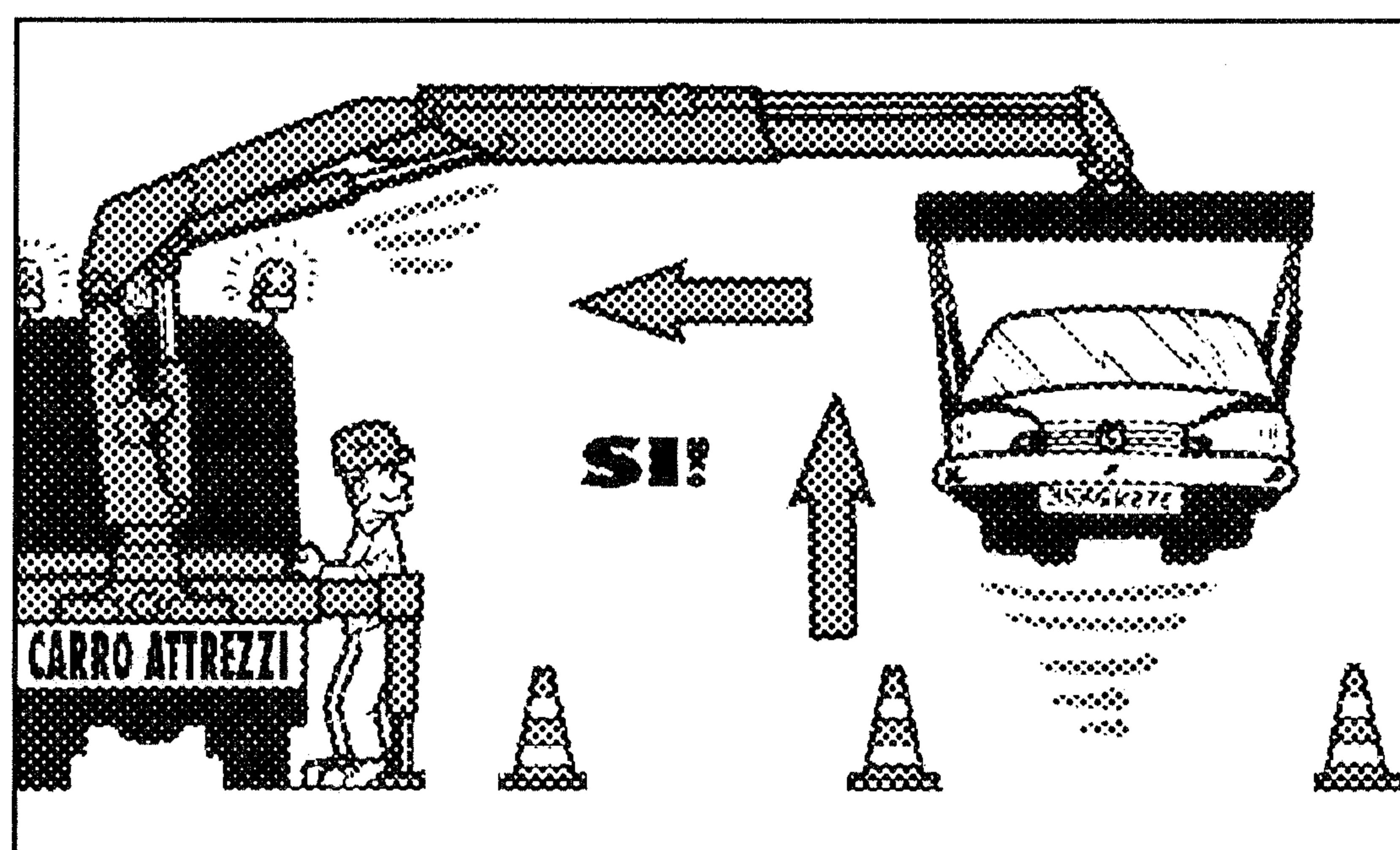
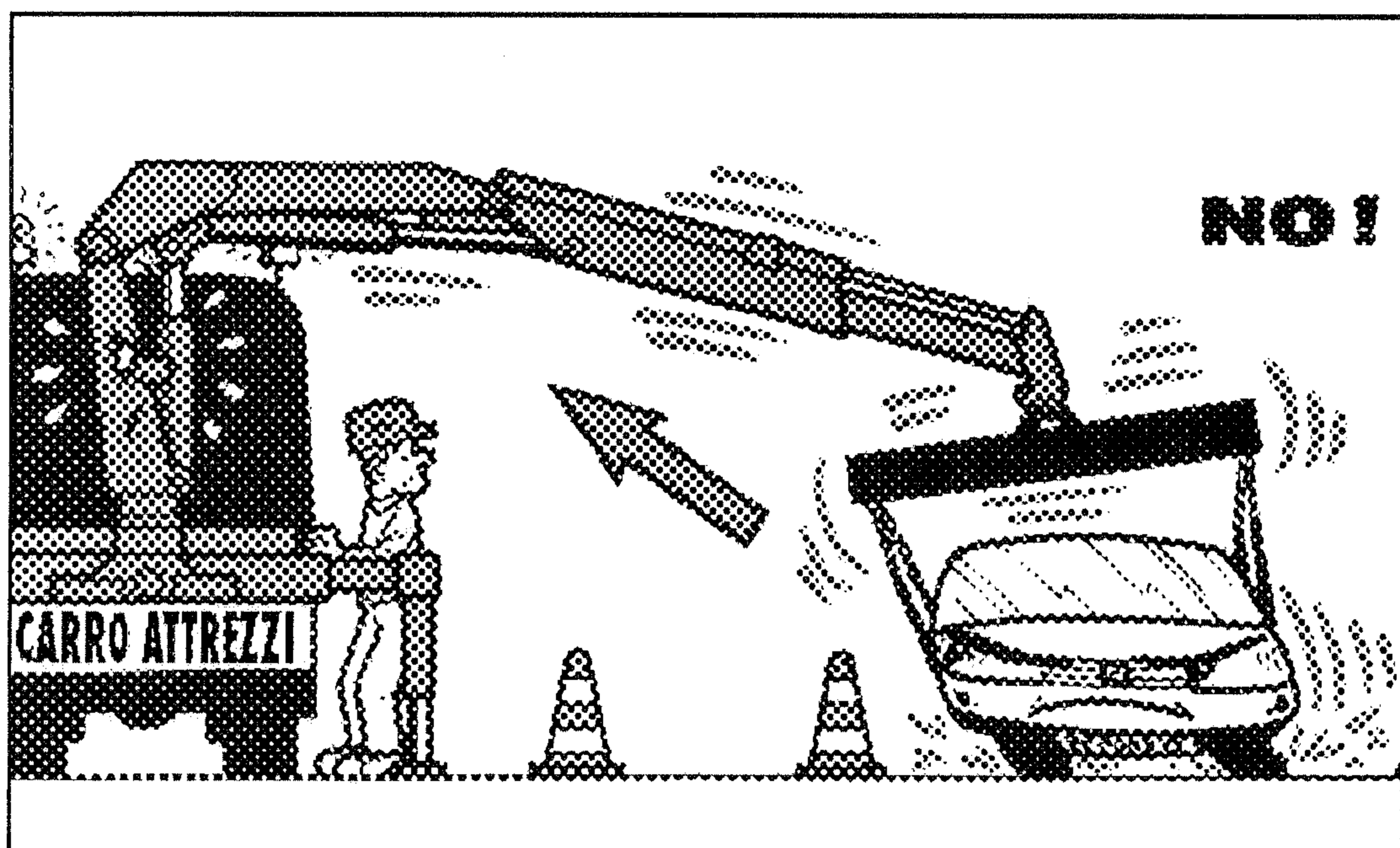

Do not rotate the crane before the load is lifted, do not operate with sudden movements, activate the controls with slow and progressive movements.

Rotate slowly and with care paying attention to the stability of the vehicle. With vertical lift, on hydraulic and mechanical extension, rotate slowly in order to avoid side-skidding.

Do not move the vehicle if a load is suspended on the crane.

Do not utilize the crane for pushpull, lateral or sideways operations.

Under no circumstances interfere with the safety and protection devices.

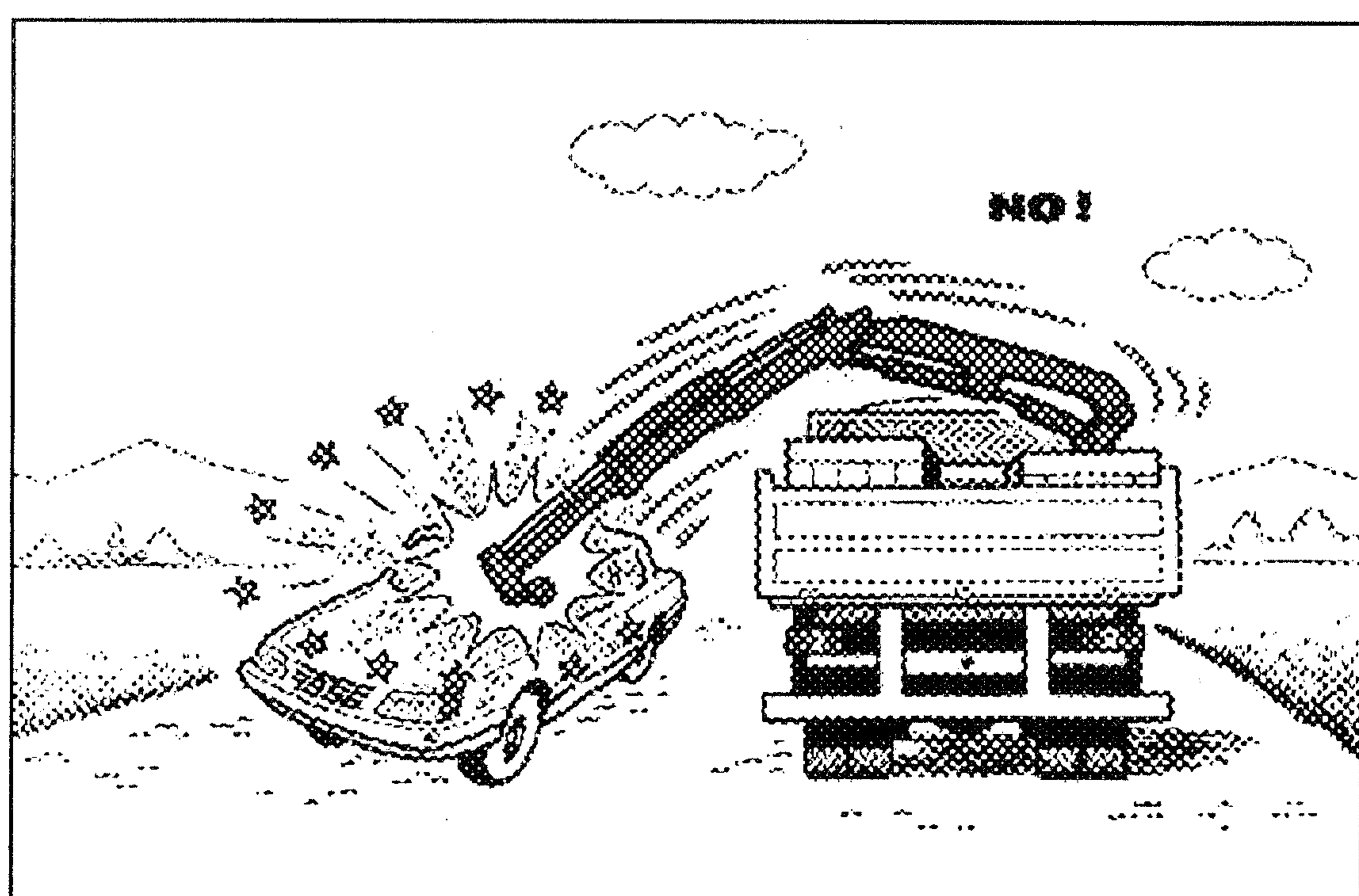

The vehicle/crane are not left unless the power take off is disengaged and the load is on the ground.

At the end of the job and prior to driving the vehicle the crane must be folded. If the booms are to be laid on the body or on the load, they must be blocked to prevent possible sideways movements.

Outrigger rams must be lifted and re-entered within the overall width of the truck

Disengage the power take off.

To avoid hitting bridges or tunnels check and record the overall height of your crane in the folded position or in laid position in the body or on the load. Always respect and pay proper attention to road signs placed in proximity of such obstacles.

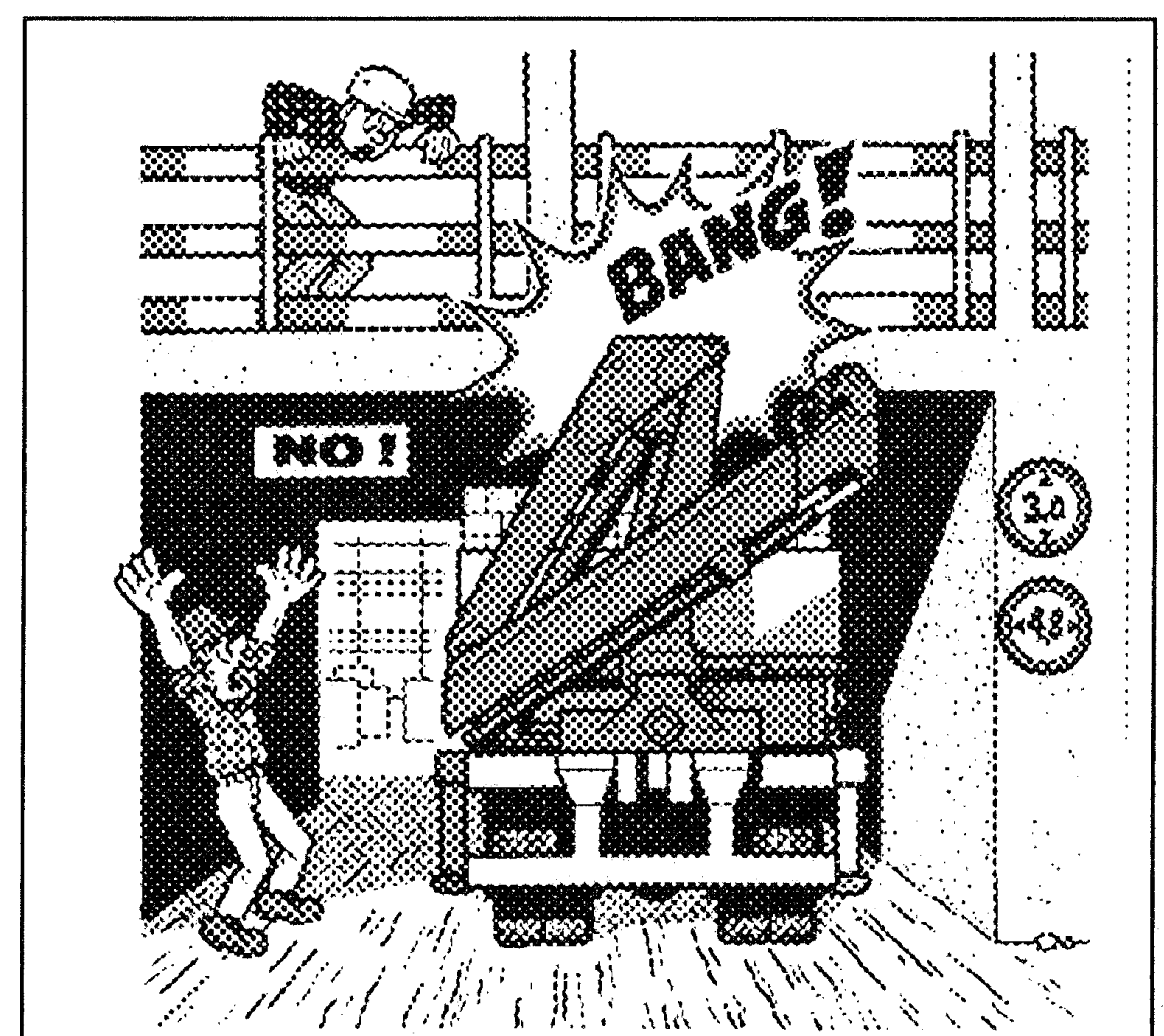

INSTRUCTIONS FOR CRANE USE

INSTRUCTIONS FOR
CRANE USE
F 300SE

c III

The use of the crane is reserved to authorized personnel, instructed in advance, who has to strictly conform to the safety norms and instructions contained in the instruction manual supplied with the crane.

- 1 — Only authorized persons are allowed to operate the crane.
- 2 — The crane must be used on firm, level ground.
- 3 — Check that the vehicle hand brake is on and that the wheels are chocked.
- 4 — Before every operation make sure that:
 - no-one is within the working area of the crane
 - the safety devices are in place and operative
 - the minimum safe working distances from power lines are observed.
 - the load is correctly slung and hooked.
- 5 — Stabilize the vehicle by the outrigger rams, making sure that:
 - the lateral supports are fully extended
 - the wheels are in contact with the ground and the suspension is not completely unloaded
- 6 — Use the crane in accordance with the use and maintenance manual, making sure that:
 - the load and radius are within the maximum limits shown on the crane capacity plate
 - the crane is used progressively avoiding sudden load movements
 - swinging or dragging of the load is avoided
 - the load is lifted before rotating.
- 7 — When using implements protect the crane working area with a barrier.
- 8 — The vehicle/crane are not left unless the power take off is disengaged and the load is on the ground.
- 9 — Before driving the vehicle make sure that the outriggers are fully retracted and re-entered, and the crane is in folded position.

fig. 1

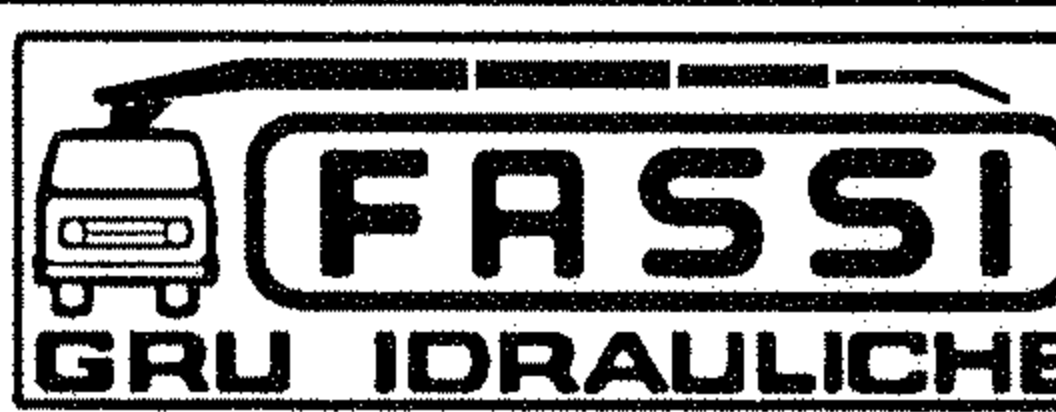
 FASSI GRU IDRAULICHE	FASSI GRU IDRAULICHE SpA 24021 ALBINO (BG) ITALY - Via dei Carmelitani, 2 Tel. + 39 35 77.64.00 - Fax + 39 35 75.50.20	INSTRUCTIONS FOR SAFE USE OF THE CRANE	DE2676
<ol style="list-style-type: none">1 Only authorized persons are permitted to operate the crane.2 The crane must be used on firm, level ground.3 Check that the vehicle hand brake is on and that the wheels are chocked.4 Before operation make sure that:<ul style="list-style-type: none">- no-one is within the working area of the crane;- the safety devices are in place and operative;- the minimum safe working distances from power lines are observed;- the load is correctly slung and hooked.5 Stabilize the vehicle with the outriggers, making sure that:<ul style="list-style-type: none">- the lateral supports are fully extended;- the wheels are in contact with the ground and the suspension is not completely unloaded;	<ol style="list-style-type: none">6 Use the crane in accordance with the use and maintenance manual, making sure that:<ul style="list-style-type: none">- the load and radius are within the maximum limits shown on the crane capacity plate;- the crane is used progressively avoiding sudden load movements;- swinging or dragging of the load is avoided;- the load is lifted before rotating.7 When using implements protect the working area with a barrier.8 The vehicle/crane are not left unless the power take off is disengaged and the load is on the ground.9 Before driving the vehicle ensure that the outriggers are fully retracted and re-entered and the crane is in the folded position.		

THESE INSTRUCTIONS FOR THE USE OF THE CRANE COINCIDE WITH THOSE OF THE PLATE DE2676 (FIG. 1) PLACED NEXT TO THE CRANE.



IDENTIFICATION OF THE CRANE MODEL

Essential data for the identification of the crane are given on the plate DE2141 fixed to the base. (Fig. 2)

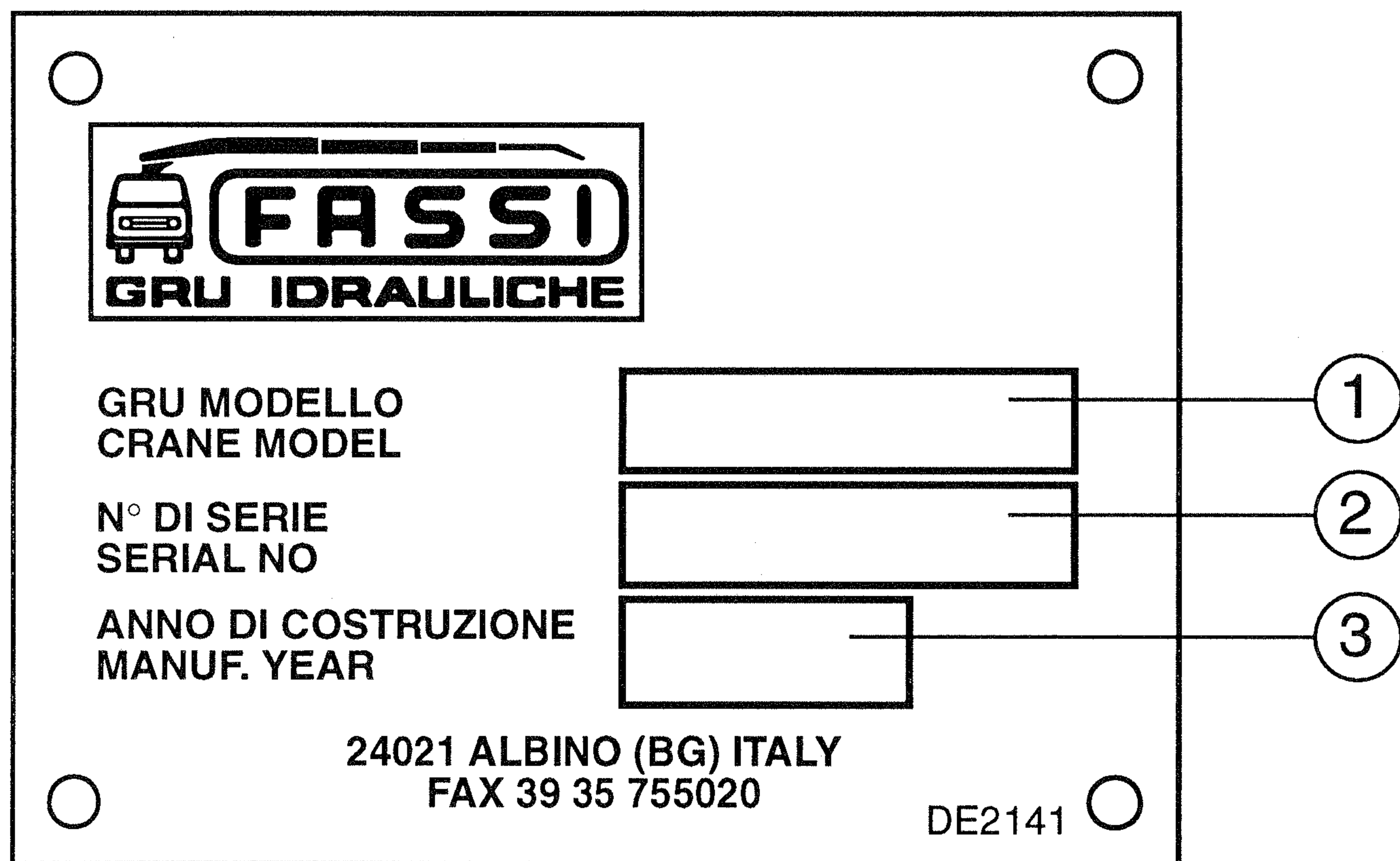

- 1 — Crane model
- 2 — Serial Number
- 3 — Year of manufacturing

fig. 2

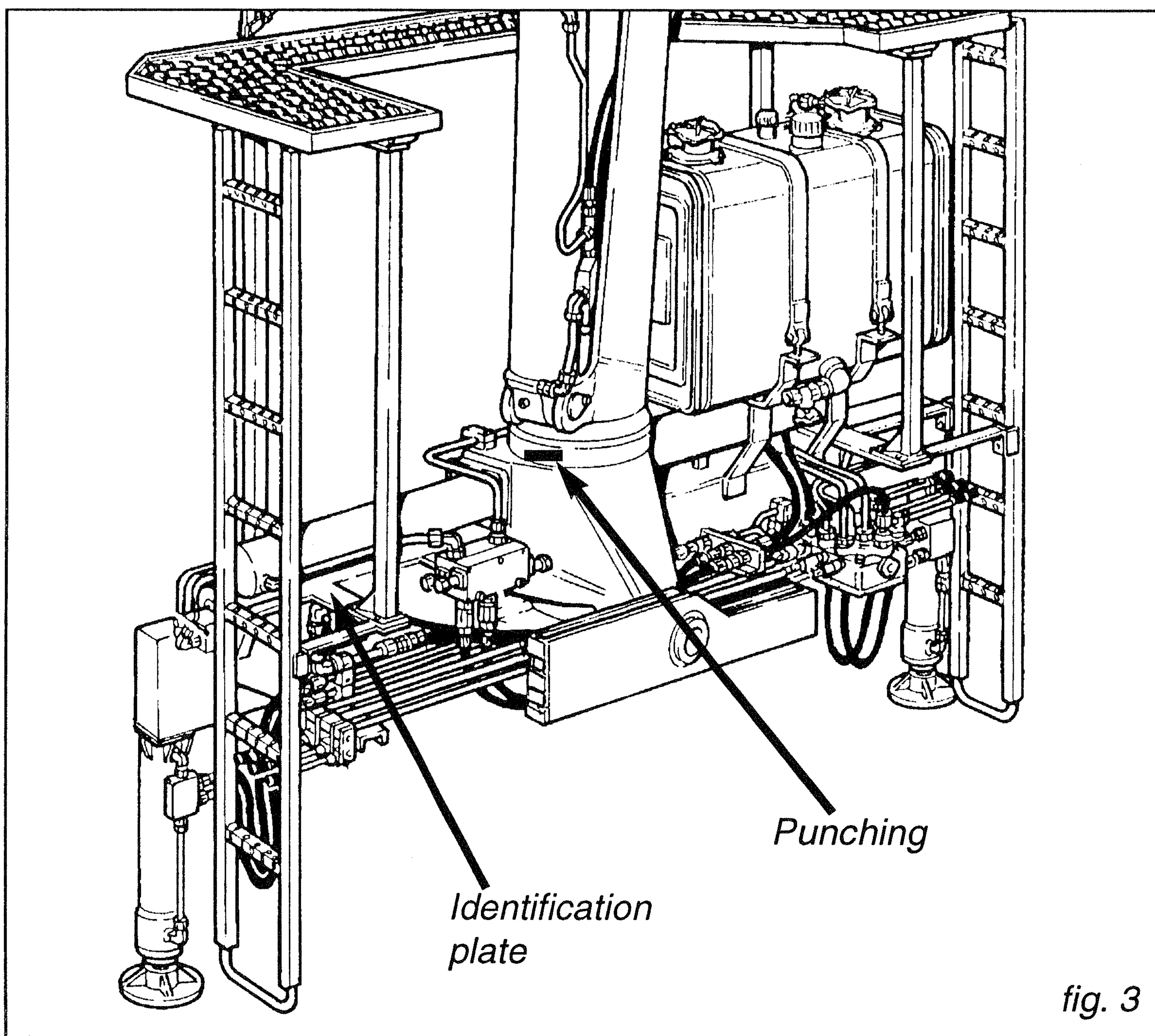

fig. 3

The model, the version of the crane, the year of manufacturing and the serial number are stamped on the base (fig. 3) in the following sequence:

F300SE.23*4*0001

			serial no.	
			year of manufacturing	
		version/ .24		
model				

(!) UNDER NO CIRCUMSTANCES SHOULD THE DATA MARKED ON THE PLATE AND PUNCHED ON THE BASE BE ALTERED.

It is essential to give the correct **crane model** and **serial number**, when you contact the Service and Parts Department.

The exact **crane model**, **serial number** and description of **implements** will enable FASSI Service Department to give a rapid and efficient response.

TECHNICAL DATA

The design of this crane has been carried out in respect of **DIN 15018** norms, fatigue test classification **H1B3**.

- (!) The crane can operate, intermittently, with lifting devices other than the hook.
The dimensions and the capacity of the implements must be proportioned with crane performances.

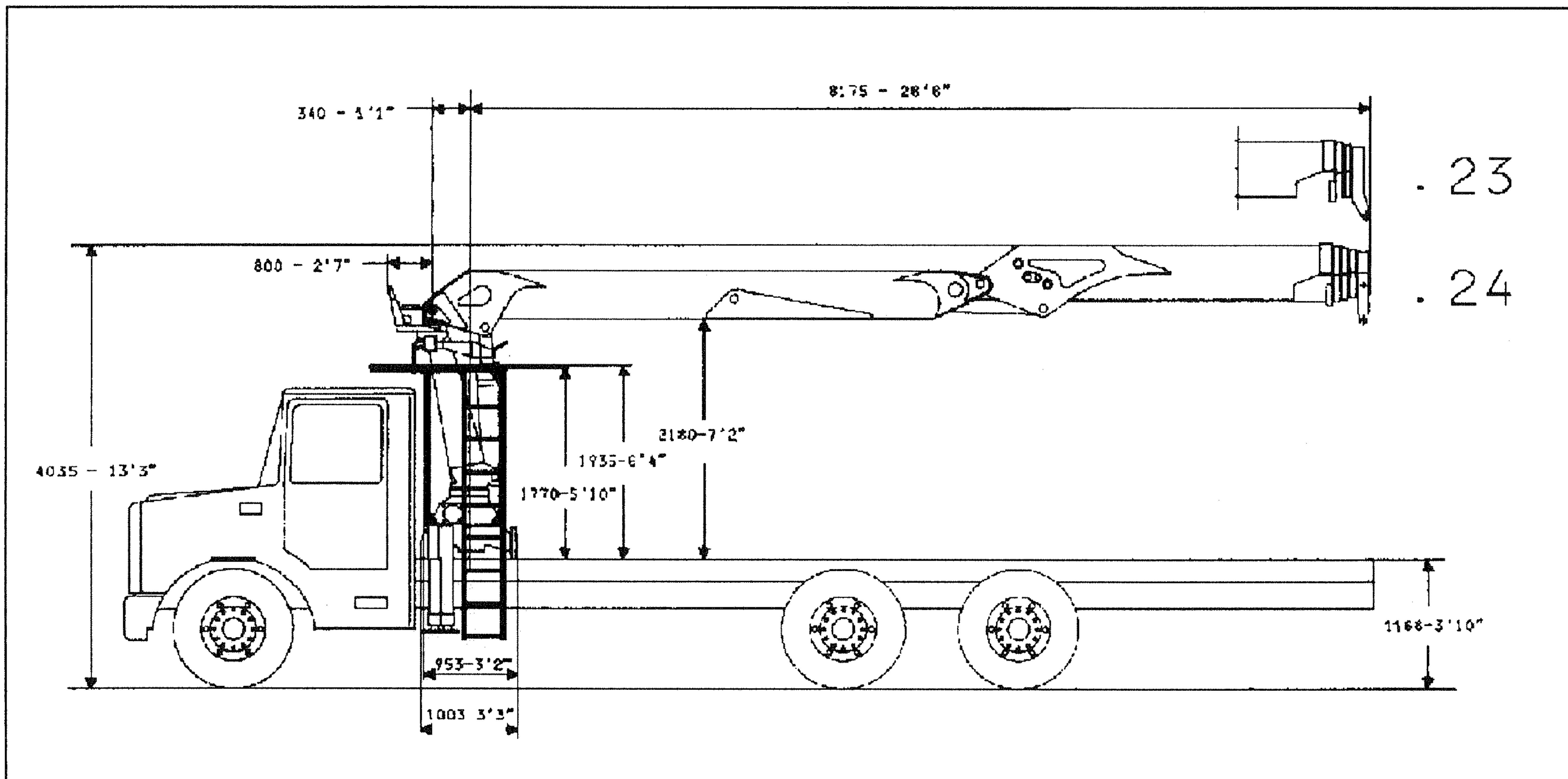

F 300SE



CO1329

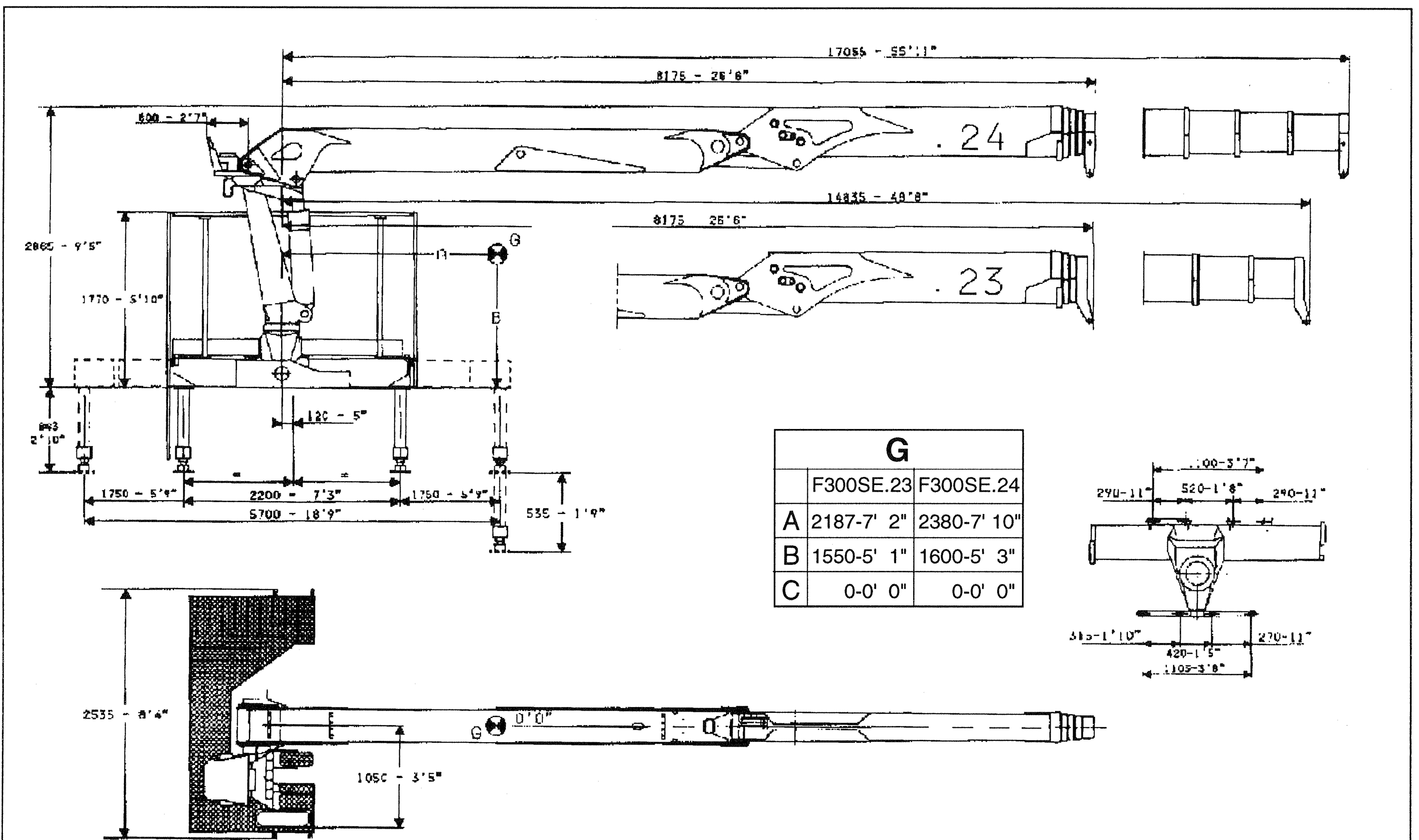

PESO GRU CON SERBATOIO NON RIFORNITO, STABILIZZAZIONE STANDARD	.23 kg 4.480 - lbs 9.890
POIDS DE LA GRUE AVEC RESERVOIR VIDE, STABILISATION STANDARD	.24 kg 4.680 - lbs 10.330
WEIGHT OF THE CRANE WITH EMPTY TANK, STANDARD STABILIZATION	.23 kg 4.480 - lbs 9.890
KRANGEWICHT MIT LEEREM TANK UND STANDARDABSTUETZUNGEN	.24 kg 4.680 - lbs 10.330

F 300SE



CO1328



F 300SE



MASSIMA ALTEZZA SOTTOGANCIO.
HAUTEUR MAXIMUM SOUS CROCHET.
MAXIMUM HOOKING POSITION.
MAXIMALHOEHE BIS KRANHAKEN



CO1240

Version with ground controls for outriggers and top seat controls for crane (fig. 4)

Pos.	Description
1	- Outrigger rams
2	- Outrigger supports with hydraulic extension
3	- Base
4	- Rotation cylinders
5	- Column
6	- Inner ram
7	- Inner boom
8	- Outer ram
9	- Outer boom
10	- Booms extension rams
11	- Extension boom sections
12	- Ladder and cat walk
13	- Seat and control station
14	- Diverter oil delivery outriggers - crane
15	- Outrigger distributor
16	- Double control for outriggers
17	- Crane distributors
18	- Joy-stick crane controls
19	- Foot crane controls
20	- Hoses for hydraulic implements
21	- Oil tank

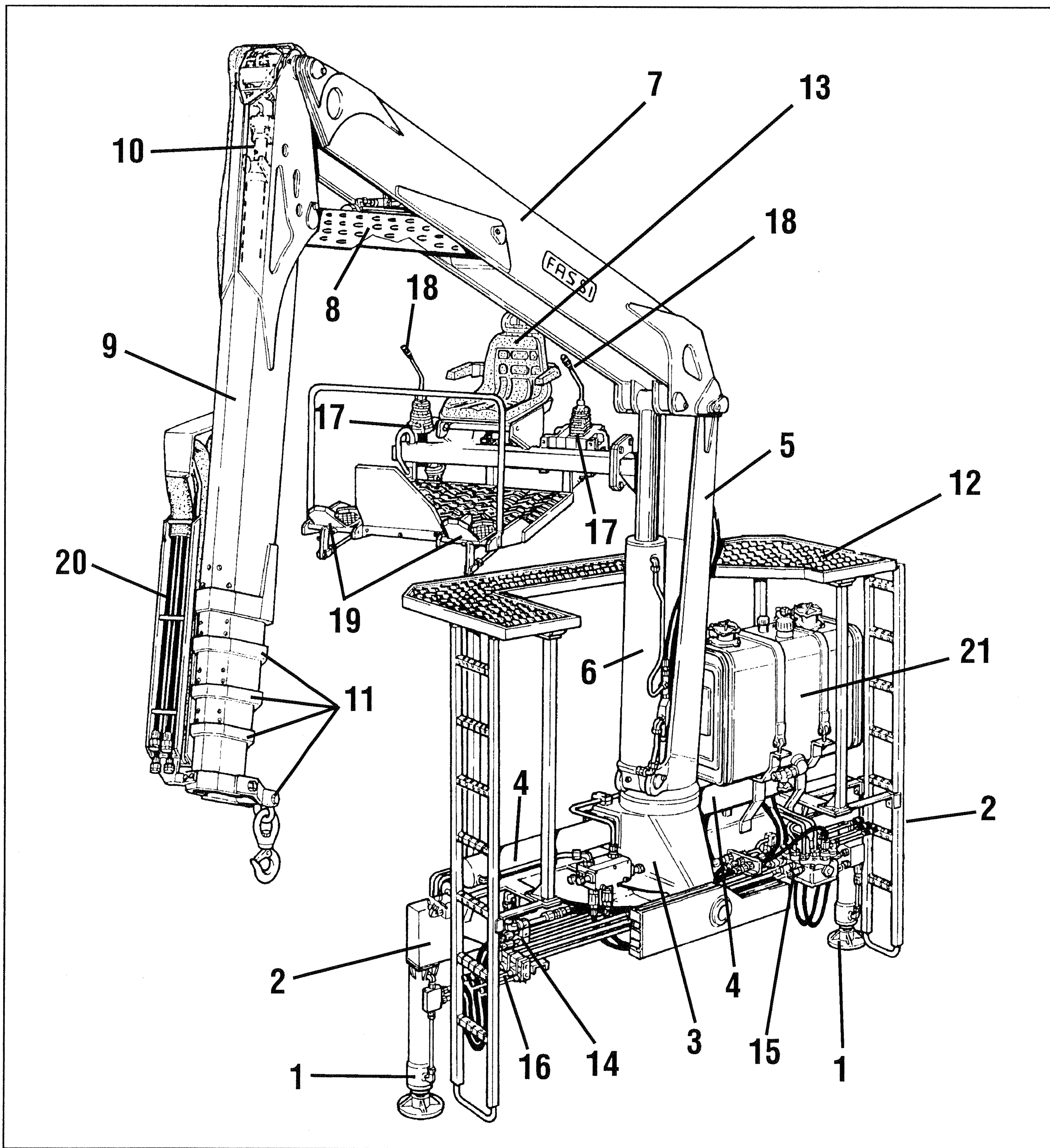

fig. 4

SAFETY AND PROTECTION DEVICES

Version with ground controls for outriggers and top seat controls for crane (fig. 5)

Pos.	Description
1	- Check valves for outrigger rams
2	- Check valve for rotation control
3	- Check valve for inner ram
4	- Check valve for outer ram
5	- Check valve for booms extension ram
6	- Lifting moment limiting device assemblies
7	- Parachute valves
8	- Main pressure valve (outriggers)
9	- Main pressure valve (crane distributors)
10	- Auxiliary valves (crane distributors)
11	- Carter for outer ram
12	- Carter for hose protection device
13	- Carter for booms extension ram check valve
14	- Handles
15	- Emergency tap lever
16	- Seat with device indicating the operator presence

(!) Before crane use check that safety and protection devices are fitted and active.

(!) Under no circumstances interfere with the safety and protection devices.

(!) Interference with the check valves and removal of the lead seals remove the Manufacturer and invalidate the warranty.

(!) Use the ladder and the cat walk for the access to the top seat.

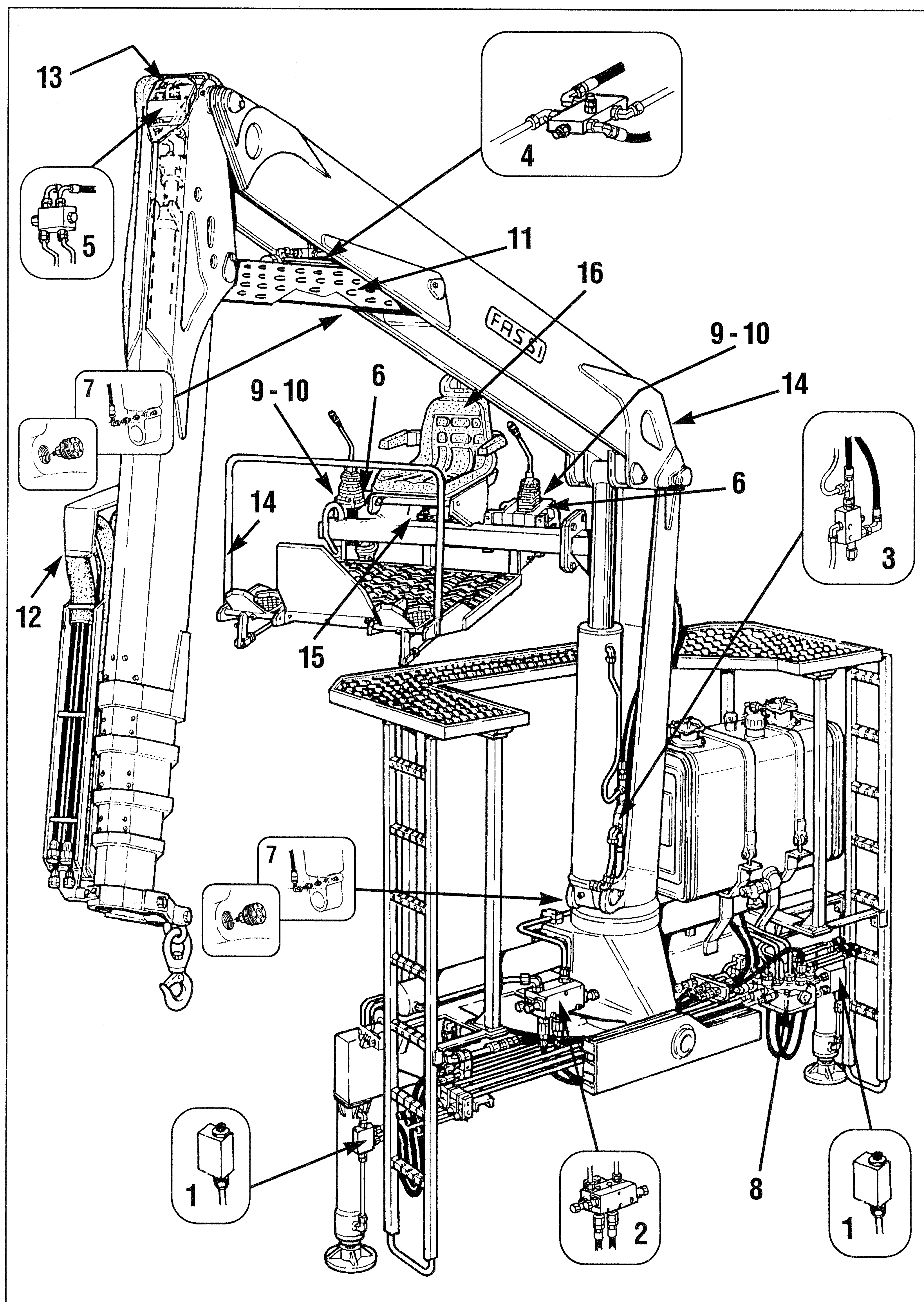

fig. 5

LIFTING MOMENT LIMITING DEVICE

A characteristic which permits the classification of cranes is their lifting capacity or maximum lifting moment. The moment is defined by the value obtained from the product of the load to be lifted (in lbs) by its distance (in ft) from the centerline of the crane rotation.

The device called "lifting moment limiting device" preserves the crane structure from overloads, as it prevents any movement which increases the value of the moment up to the maximum established value.

Lifting moment limiting device "INTELLIGENT TYPE"

This device is fitted close to the distributor, whose specific functions it uses. It utilises an electrohydraulic technology, preventing any movement which causes an increase in the pressure induced by the load in the inner and outer rams of the crane, up to the "critical values" which have been established in the structural test. These values, which are non-exceedable, determine the intervention levels and provide the data for setting the device.

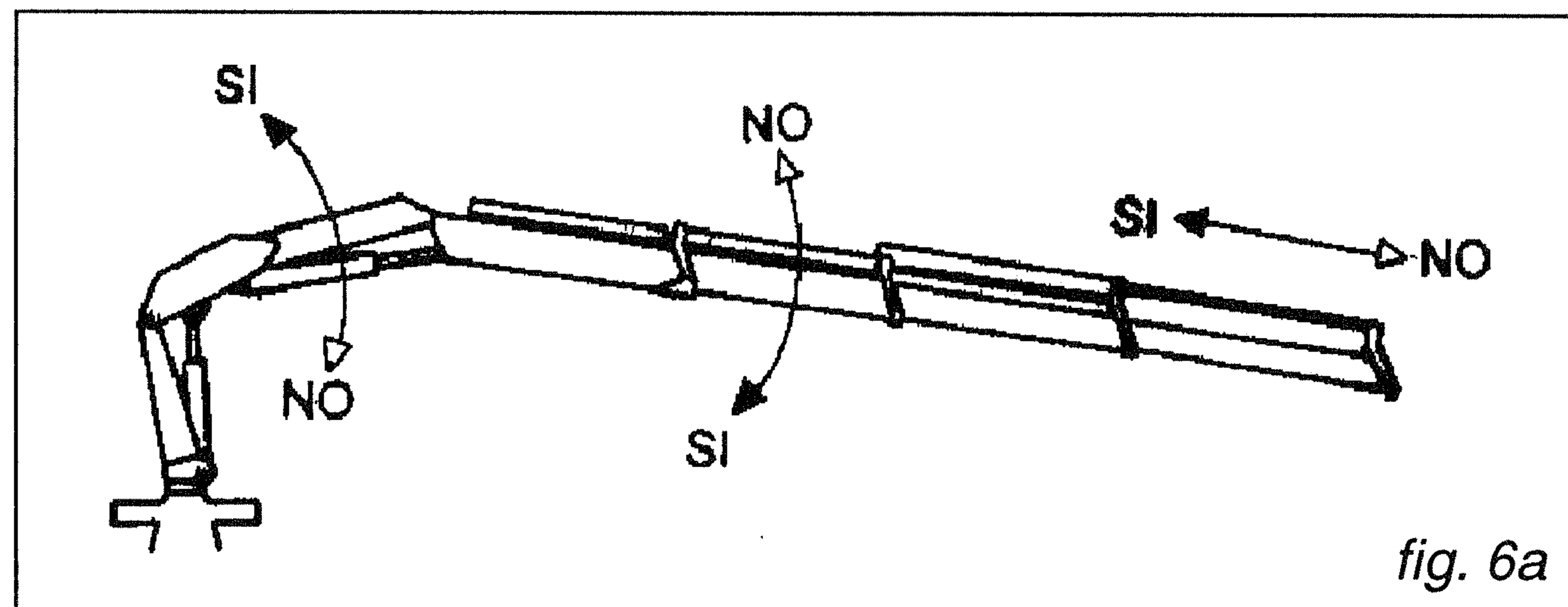
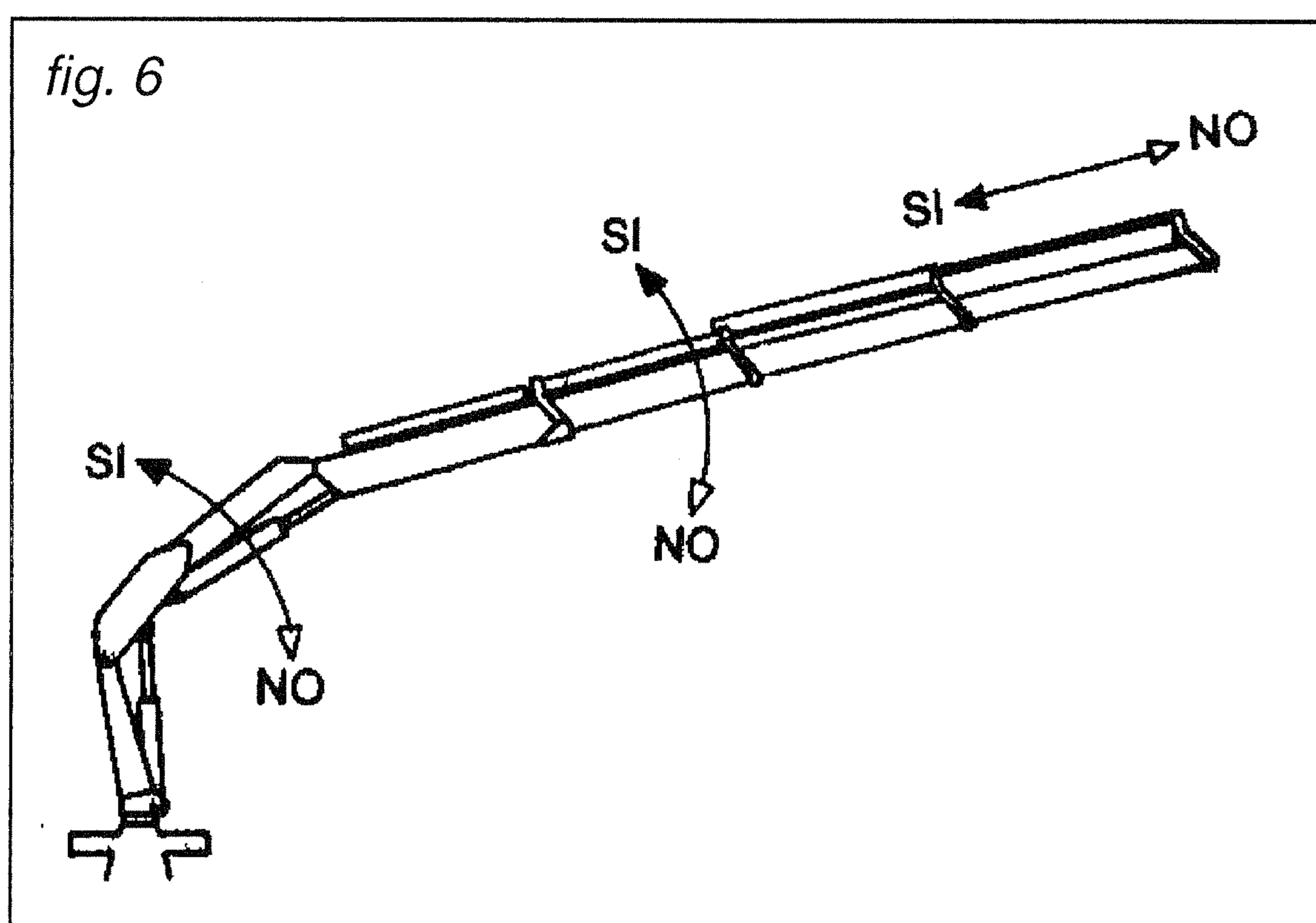

The lifting moment limiting device concerns the following manoeuvres:

- Inner boom descent; the inner boom lift is controlled by the general main pressure valve of the distributor.
- Outer boom lift.
- Outer boom descent.
- Extension of extension boom sections.

The device is based on hydraulic controls which are activated when the intervention value is reached and block the movements of the relevant distributor levers in one or both directions. Please remember that the device will return the lever of the element being used to neutral position.

The condition of intervention is operated by the position of the outer boom, on which the electronic signal position (mercury level switch) is read

by a special electrovalve. This determines the controls of the locking or unlocking (resetting) of the controls concerned.

The crane configurations (fig. 6-6a) indicate the manoeuvres which are allowed and not allowed by the device, in connection with the horizontal position of the crane and extension outer booms.

fig. 7

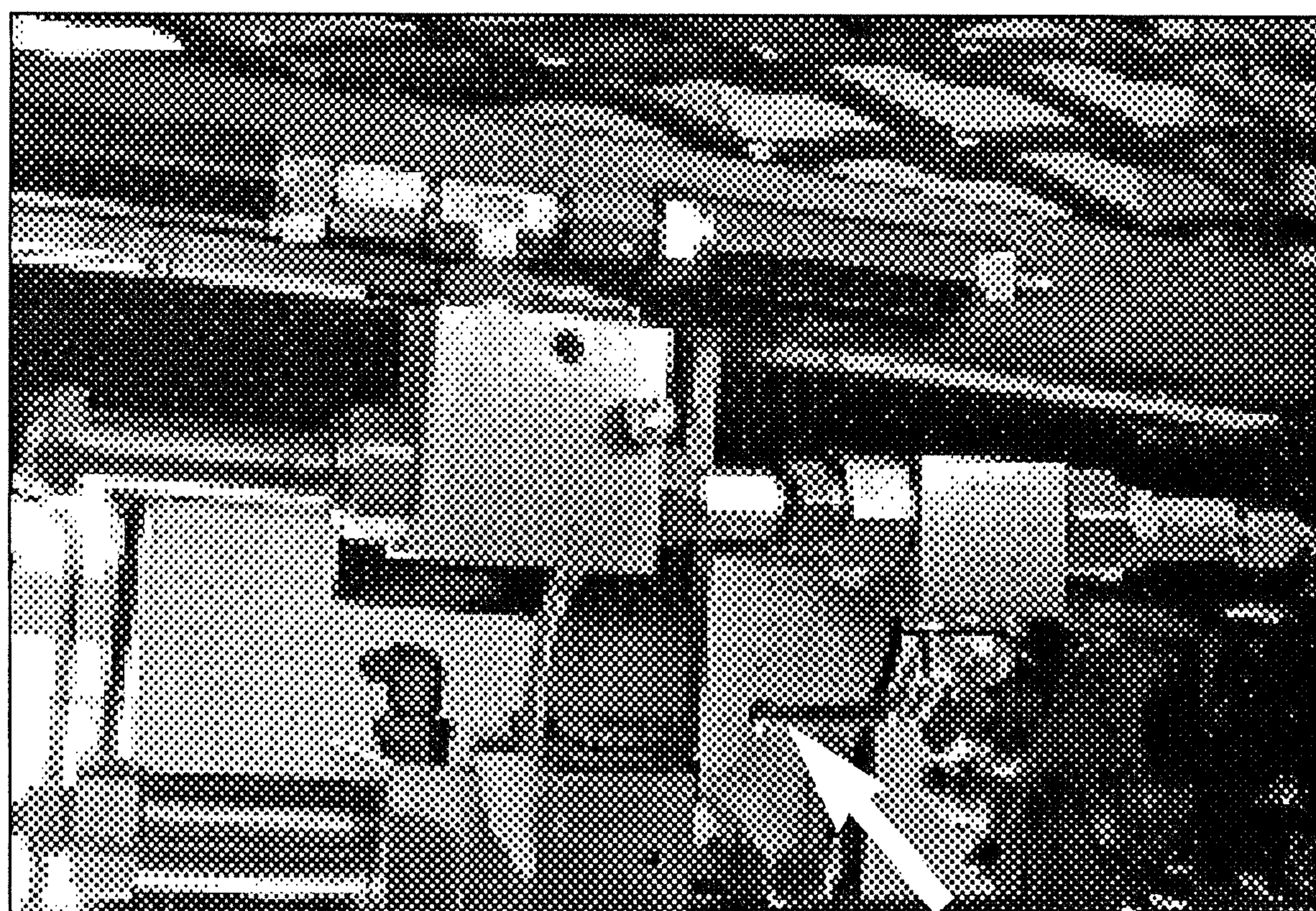

!NOTE! In the absence of electric power all crane functions will be deactivated.

REACTIVATION device of crane functions in the absence of electric power.

- (!) Each device is installed with an exclusion tap (fig. 7) which allows reactivation of all the crane functions in case of absence of the electric power. Only in these conditions it is permitted to remove the lead seals which protect the lever and place it in the closed position.

EMERGENCY exclusion tap of the lifting moment limiting device

Every electrovalve is installed with a screwed tap (emergency exclusion tap), which must only be used in case of emergency, testing or other abnormal situations when it is not possible to carry out any of the movements allowed by the device. (Such a probability generally occurs when the extension booms are completely re-entered or the loads are considerable and voluminous.) Only In these situations it is permitted to remove the lead seals which protect the device. Slacken the lock nut of the screwed tap fig. 8 (14 mm hexagonal spanner), completely screw in the tap (5 mm allen key) and re-tighten the lock nut.

fig. 8

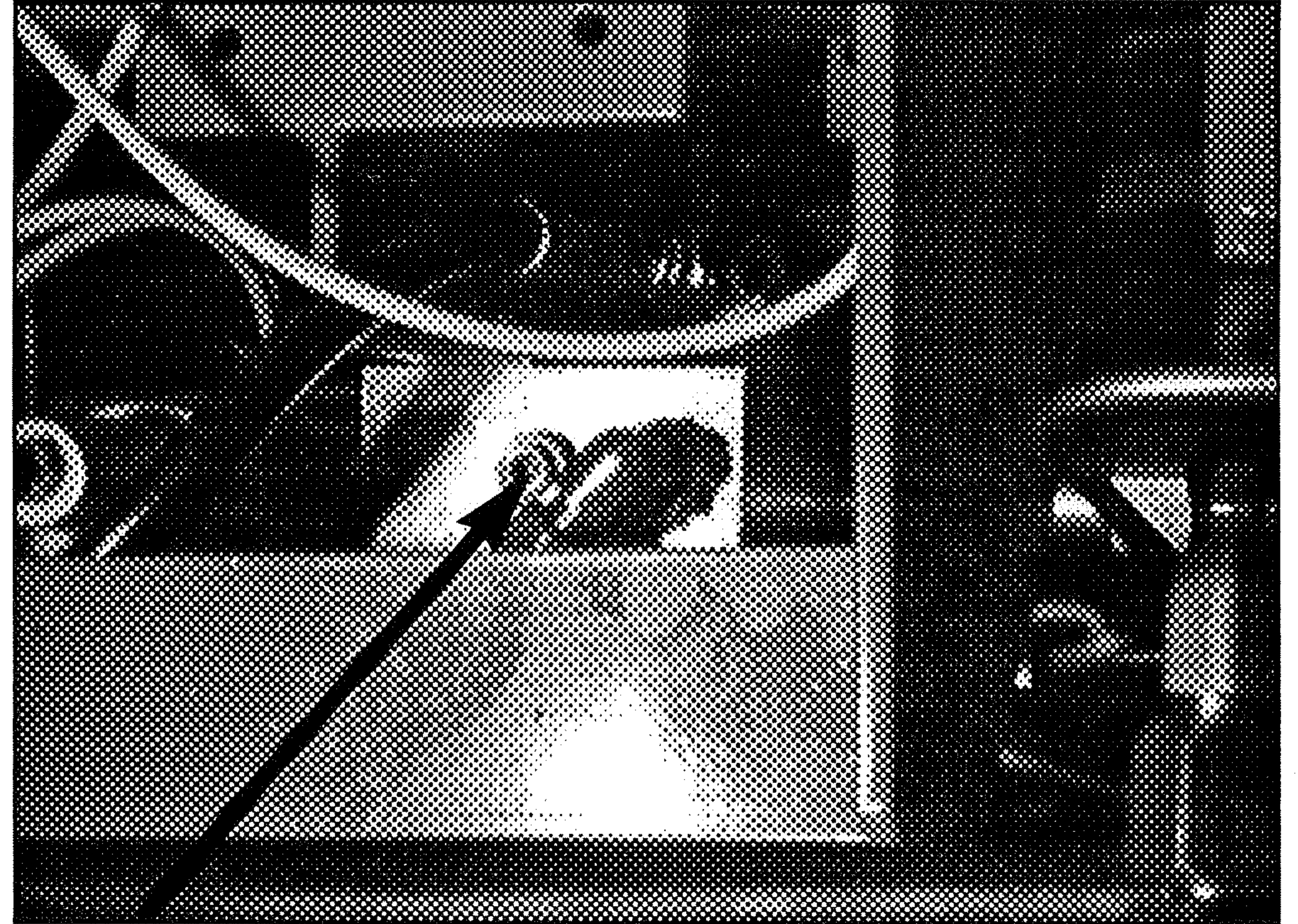

(!) ATTENTION (!)

When the operator uses this device, it means that he wishes to override the lifting moment limiting device in order to make some manoeuvres (which would be impossible with the device active) that bring the moment to within the level, but involve an overload condition. In such an emergency condition (where the lifting moment limiting device has been disabled), the operator must be:

- carefully consider the manoeuvres required to return to normal working conditions;
- calmly and carefully assess the type and scale of the hazards arising from these manoeuvres and the possible reaction of the crane (tipping over, frame overload, uncontrolled fall of the load due to a hydraulic system overload etc...);
- make all movements as slowly as possible to reduce the dynamic overload to the minimum.

After such emergency operations and prior to re-use of the crane, you must immediately go to FASSI authorised Center for testing the structure and re-sealing of the device.

(!) Interferences with the valves or removal of the lead seals release the Manufacturer from any responsibility and invalidate the warranty.

(!) ATTENTION (!)

The presence of the lifting moment limiting device does not release the user from the obligation to respect what is indicated on capacity plates and lifting curves.

(!) ATTENTION (!)

Do not walk on the electric panels. (DE1679)
Do not use water to extinguish fire! (DE1680)



CONTROLS TO STABILIZE THE VEHICLE

The outriggers rams prevent harmful stresses both to the frame and to the vehicle suspensions on which the crane is mounted and assure the stability of the unit during load handling.

(!) **The crane stability is only guaranteed by the maximum lateral extension of the outrigger supports of the crane**

DOUBLE CONTROL SIDE

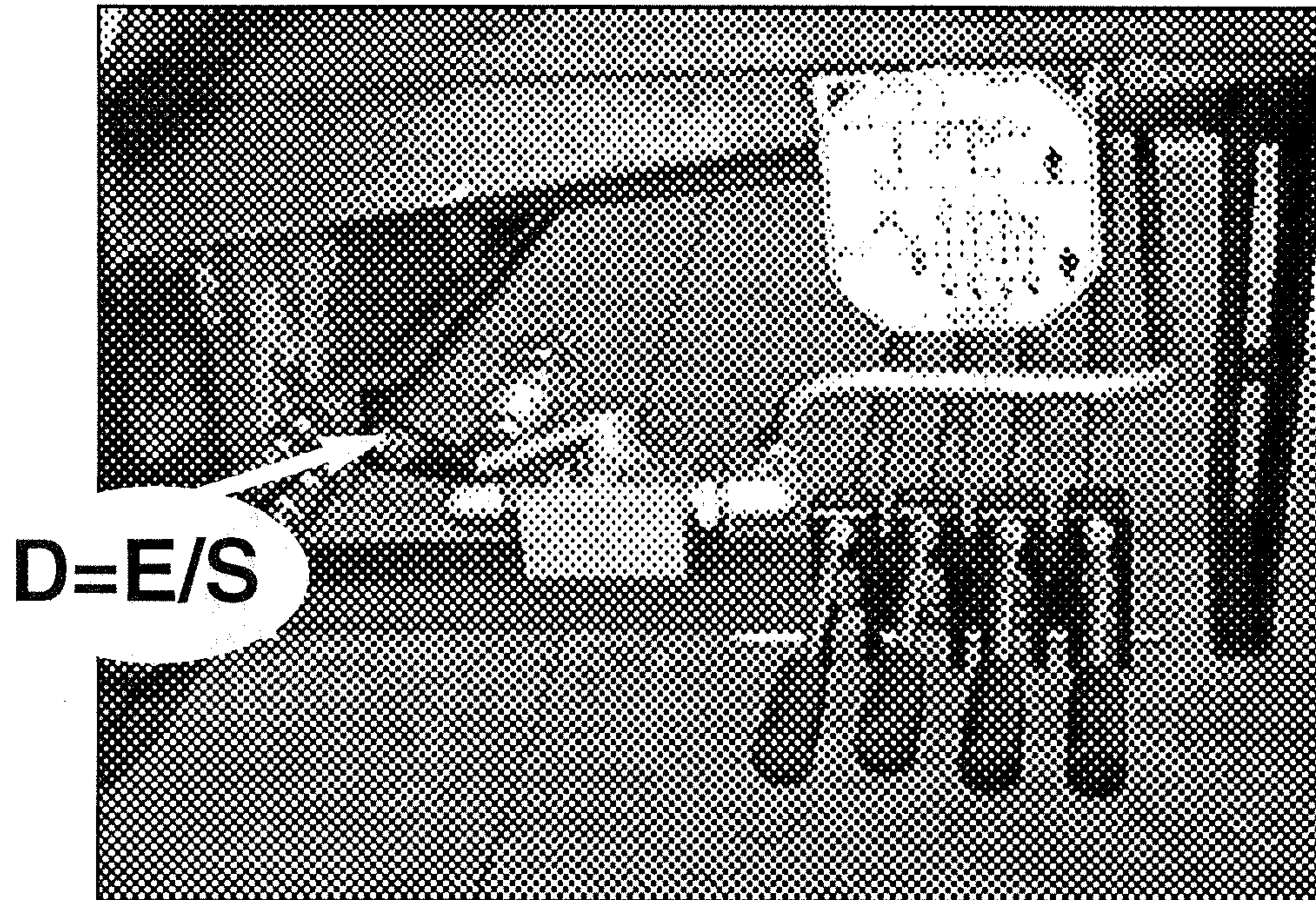

fig. 9

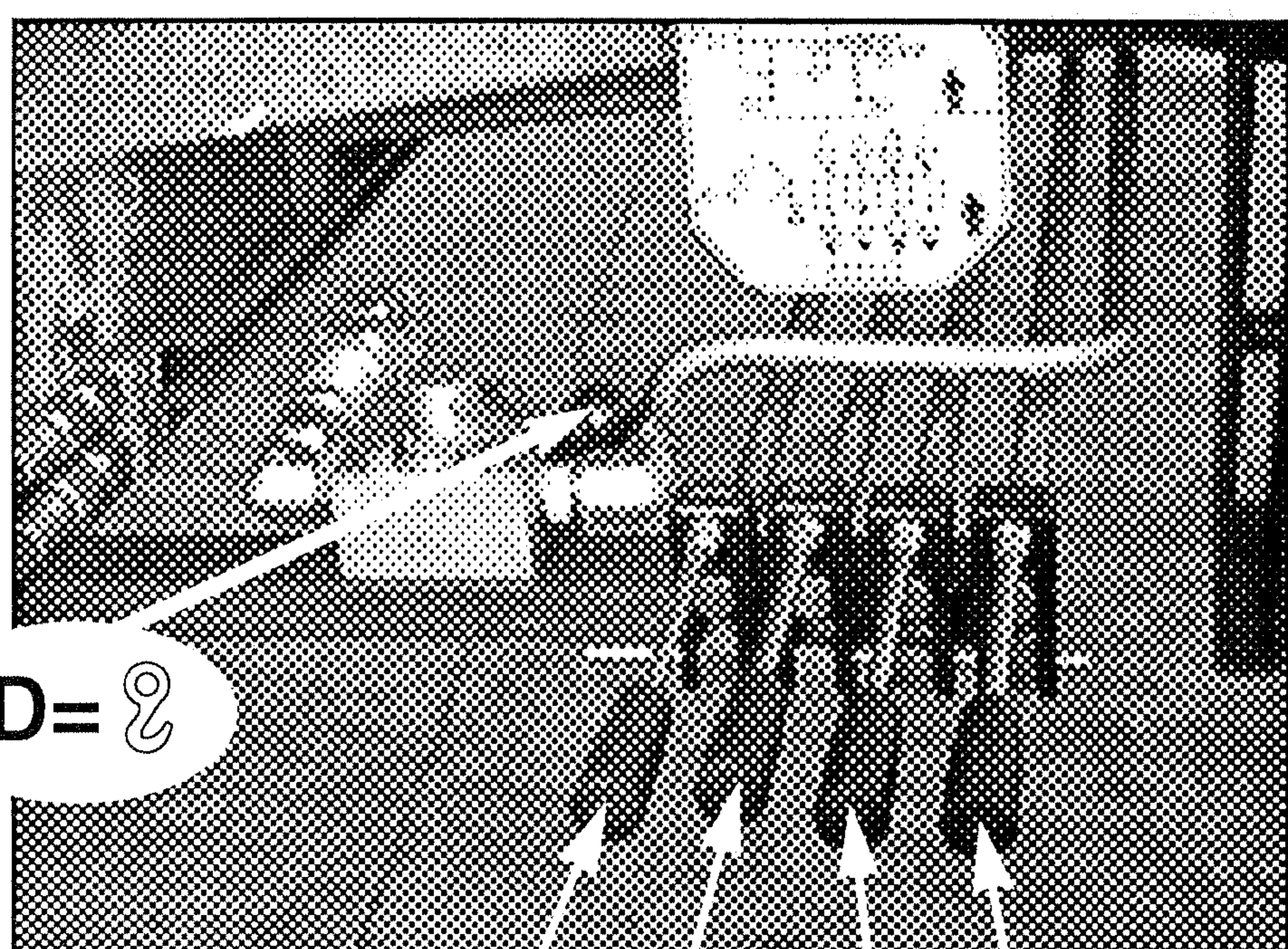

fig. 10

S2 S1 E2 E1

fig. 11

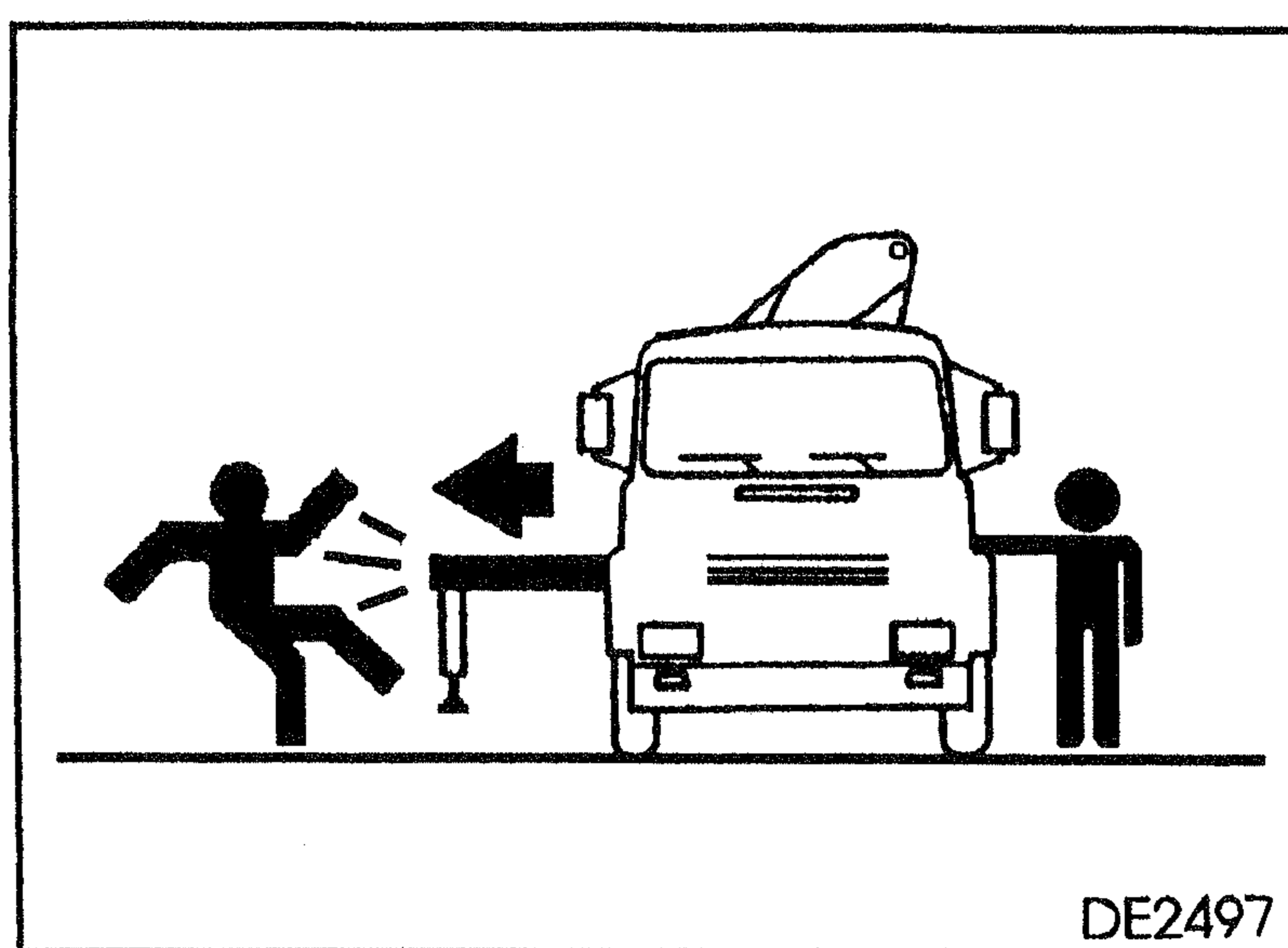
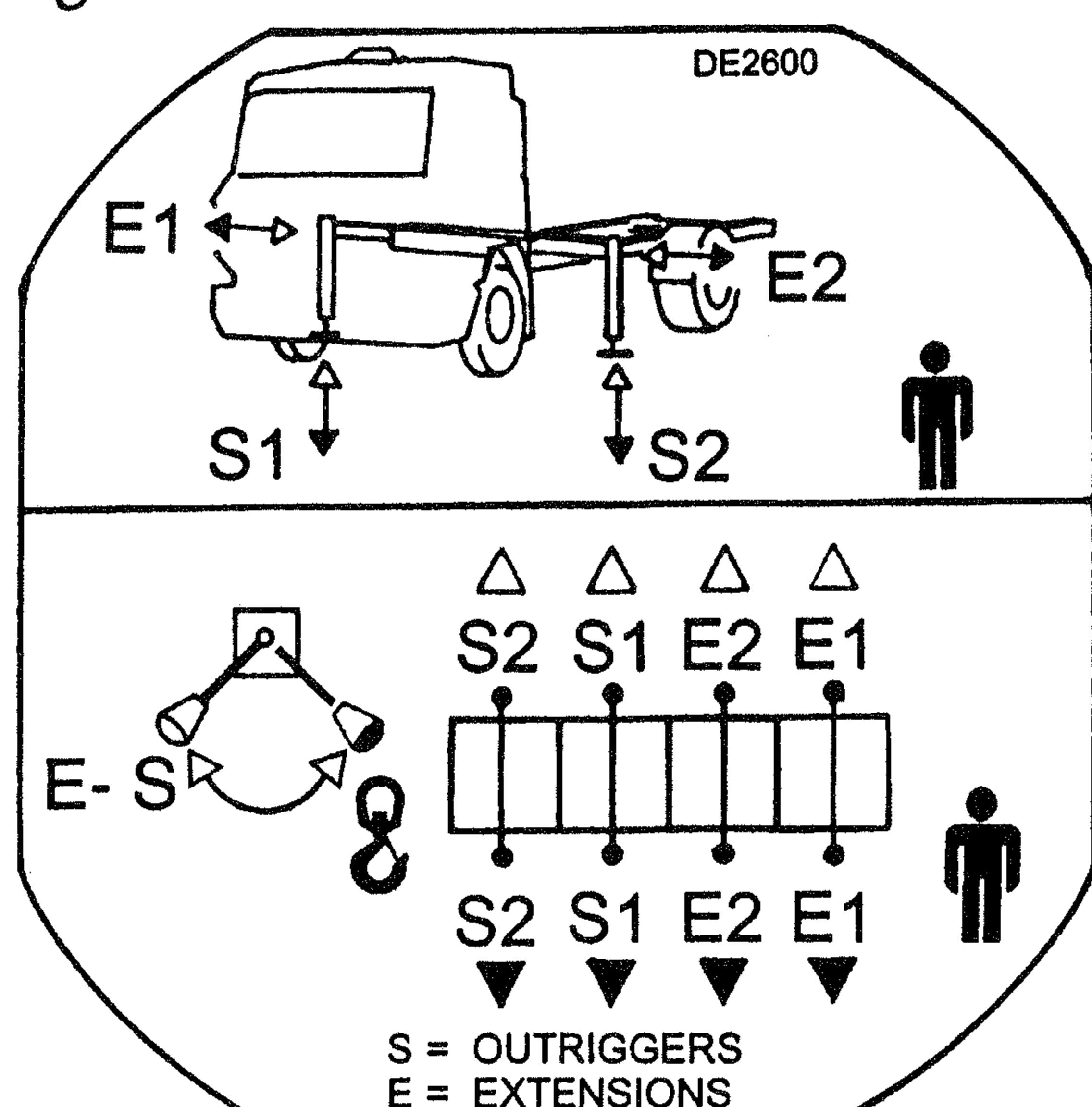

fig. 12



Be very careful during vehicle stabilization operation; make sure that no one is or transits in close proximity of the working area of the outriggers.

When stabilization is complete the wheels of the vehicle must still be in contact with the ground and the suspensions must not be fully unloaded.

Level the crane so as to operate on a horizontal plane.

The controls to stabilize the vehicle are activated only on ground and are on both sides (from distributor side or from double control side).

Description of the controls to stabilize the vehicle

(!) The extension and re-entering of the support and outrigger rams indicated on the fig. 12-15 coincide with what indicated on the plates **DE2600** and **DE2601** placed next to the control station.

The upper part of the plates indicates the side of the vehicle from which the operation is carried out with the possibilities of outrigger supports extension and outrigger rams descent.

The lower part of the plates indicates the controls position and the levers operating direction.

On the plate **DE2600** (fig. 12) is also reported the oil diverter (placed on the side of the base beam (fig. 9-10) on the left side of the vehicle) with the position of the lever for E/S control (**E**=extensions, **S**=outriggers).

Lever function E1 - E2 - S1 - S2 of fig. 10-13

E1 – **E1** outrigger support extension control

E2 – **E2** outrigger support extension control

S1 – **S1** outrigger ram control

S2 – **S2** outrigger ram control

– Position lever **D** of oil diverter E/S , (placed on the beam of the crane base, on the left side of the vehicle), on **E/S** (extensions - outriggers). (Fig. 12)

(!) ATTENTION (!)

When controlling from the opposite side of the vehicle (it is not possible visually check the operation) it is compulsory make sure that no one is or transits in close proximity of the outriggers. (Fig. 11 plate **DE2497** and fig. 14 plate **DE2498**).



- Operate lever **E1** to extend the outrigger support **E1**
- Operate lever **E2** to extend the support **E2**
- Operate lever **S1** to control the descent of the outrigger ram **S1**
- Operate lever **S2** to control the descent of the ram **S2**.

(!) ATTENTION (!)

During the stabilisation operations, for each outrigger ram, it is recommended to DESCENT the outrigger as last manoeuvre.

(!) ATTENTION (!)

The complete extension of the outrigger supports is visually indicated by the yellow triangles which are found at the end of the beam. The stabilization has to be carried out with care and gradually keeping the vehicle in horizontal levelled condition to prevent springs overloads and chassis torsions.

To have the crane in working condition, position lever **D** of oil diverter  - **E/S**, placed on the base beam, on . (Fig. 10)

Manoeuvres for re-entry of the crane outriggers after crane use.

- Position the lever of oil diverter  - **E/S**, on **E/S** (extensions - outriggers). Fig. 9
- Operate lever **S1** to control the re-entry of the outrigger ram **S1**
- Operate lever **S2** to control the re-entry of the ram **S2**
- Operate lever **E1** to re-enter the outrigger support **E1**
- Operate lever **E2** to re-enter the support **E2**

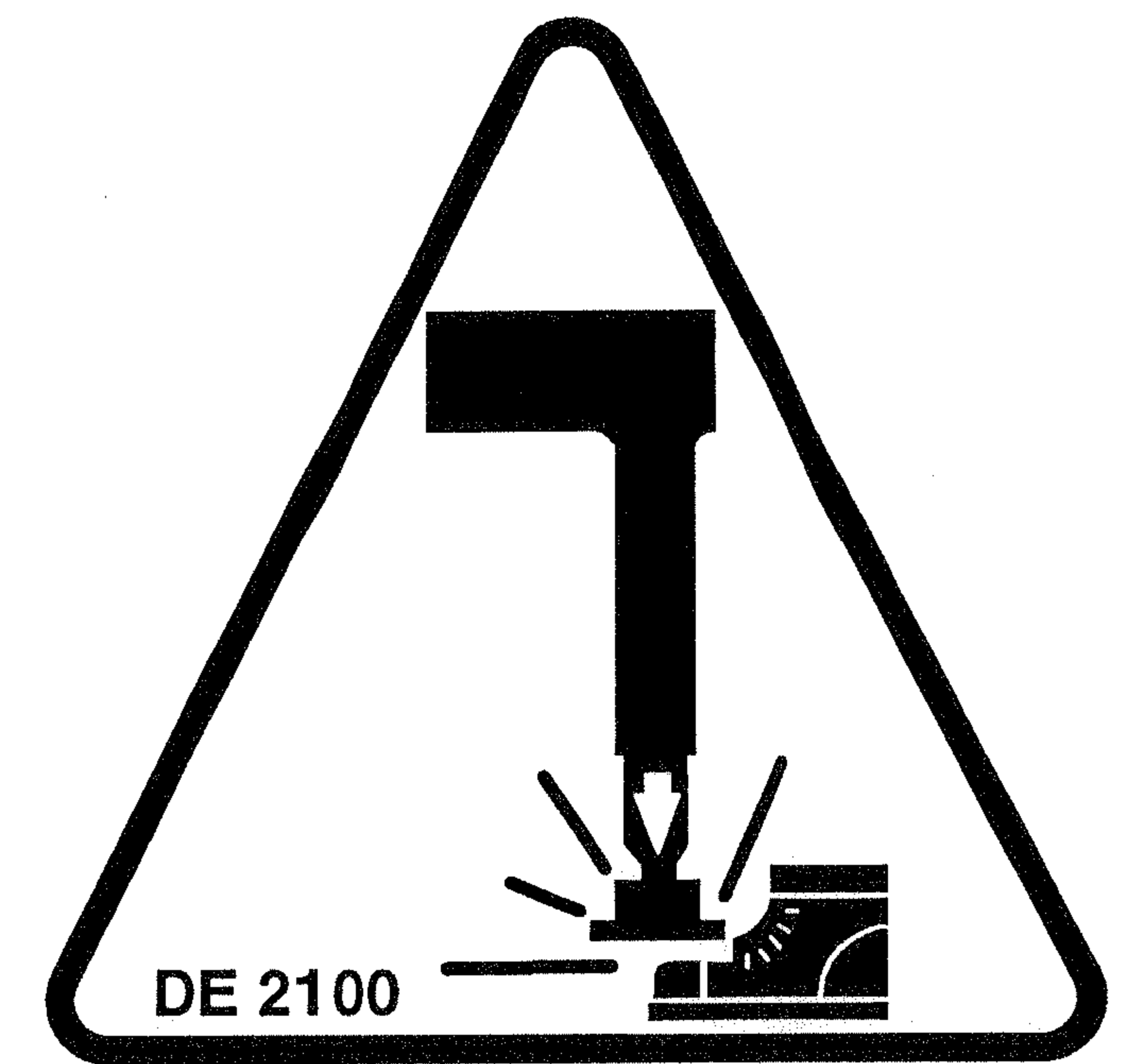

DISTRIBUTOR SIDE

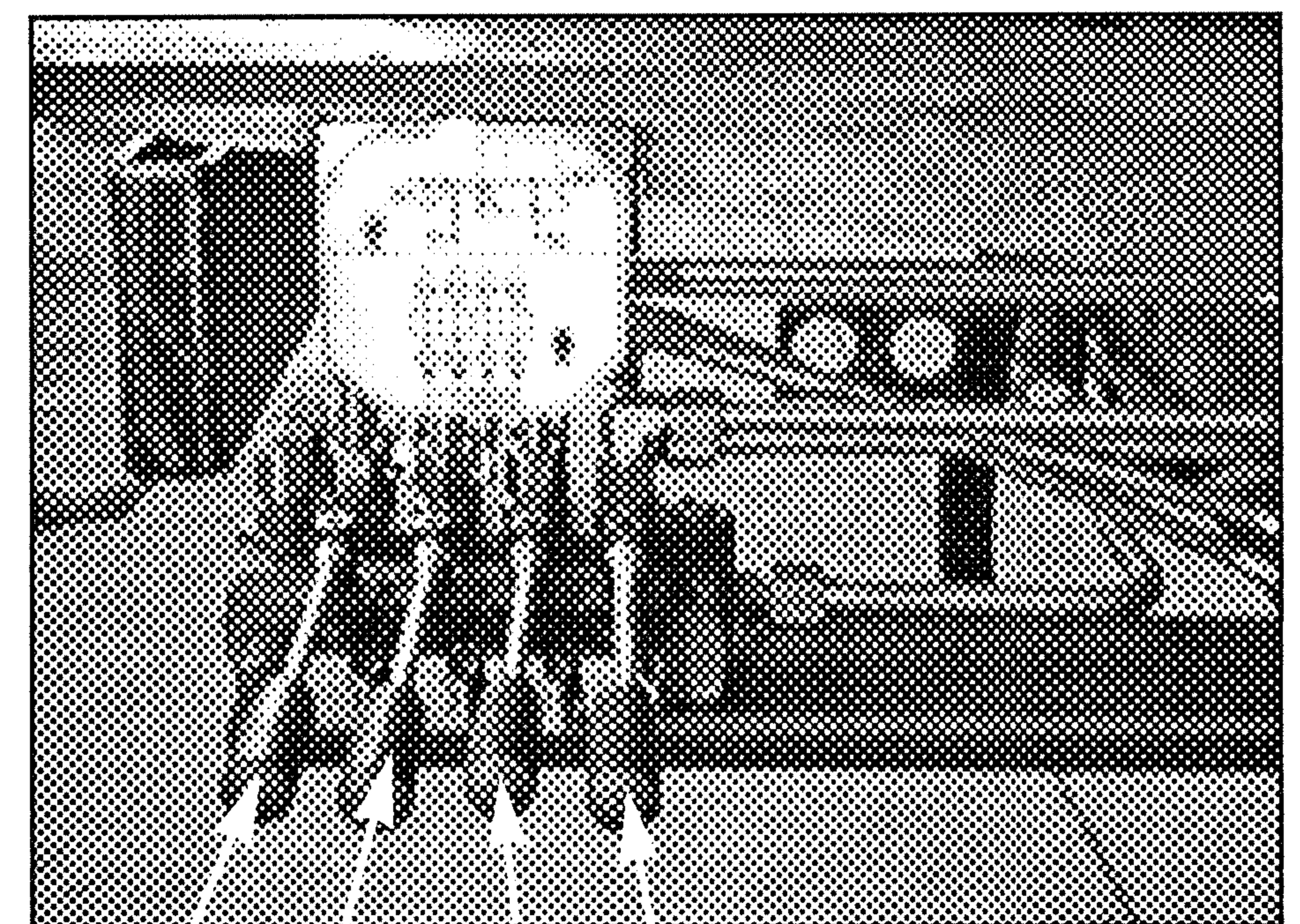

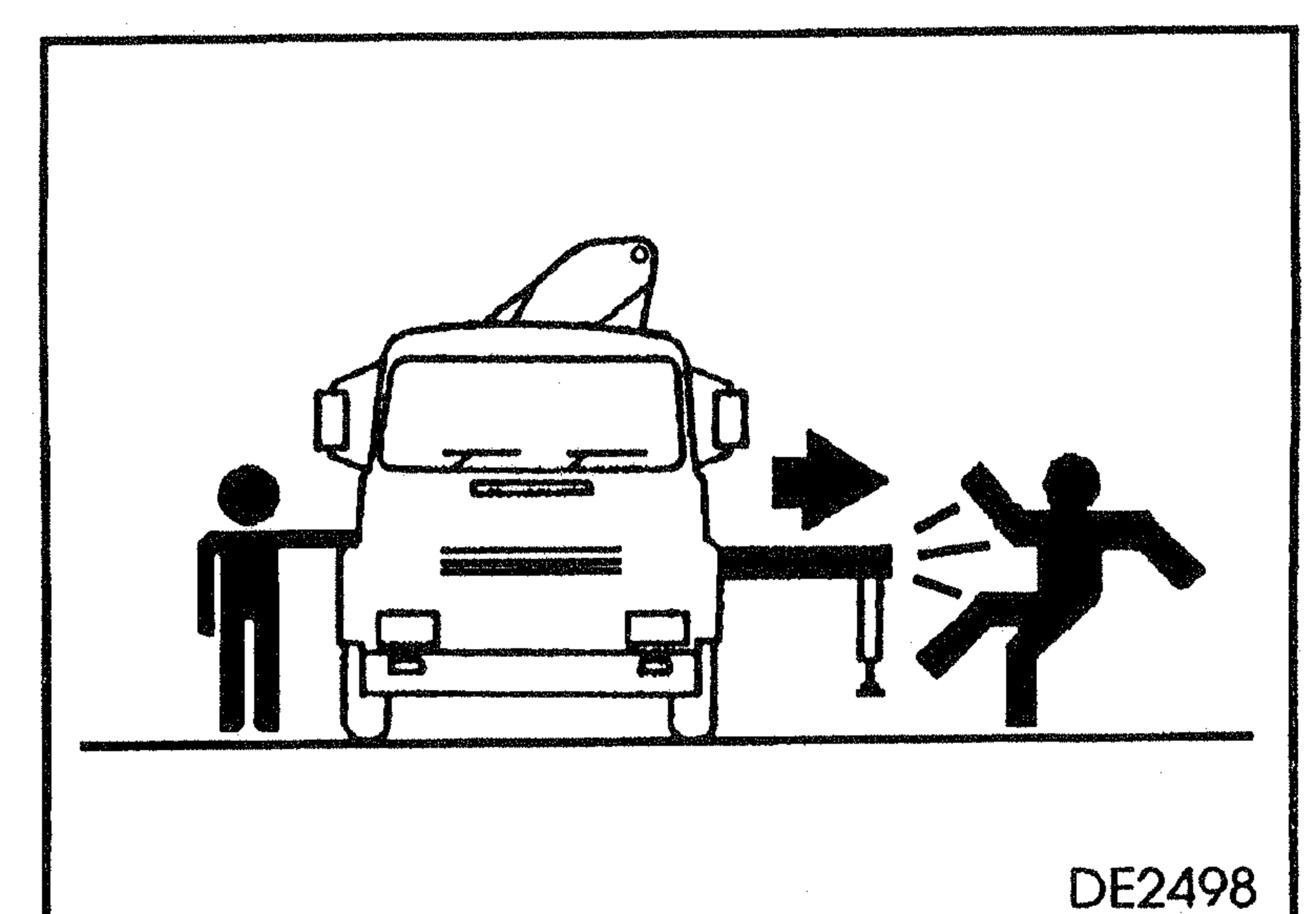

fig. 13

E1 E2 S1 S2

(!) WARNING (!)

due to the particular characteristic of the hydraulic circuit (double circuit with two pumps), the distributor placed on the right of the top seat (outer boom control, pallet-fork and extension booms) is alimented by one pump also with the oil-diverter  - **E/S** on **E/S**; the distributor controls are disactivated by a device indicating the operator presence which prevents the control activation before the operator sits down at the control station.



DE2498

fig. 14

- (!)** Under no circumstances interfere with the device indicating the operator presence which is fitted on the seat of the control station.

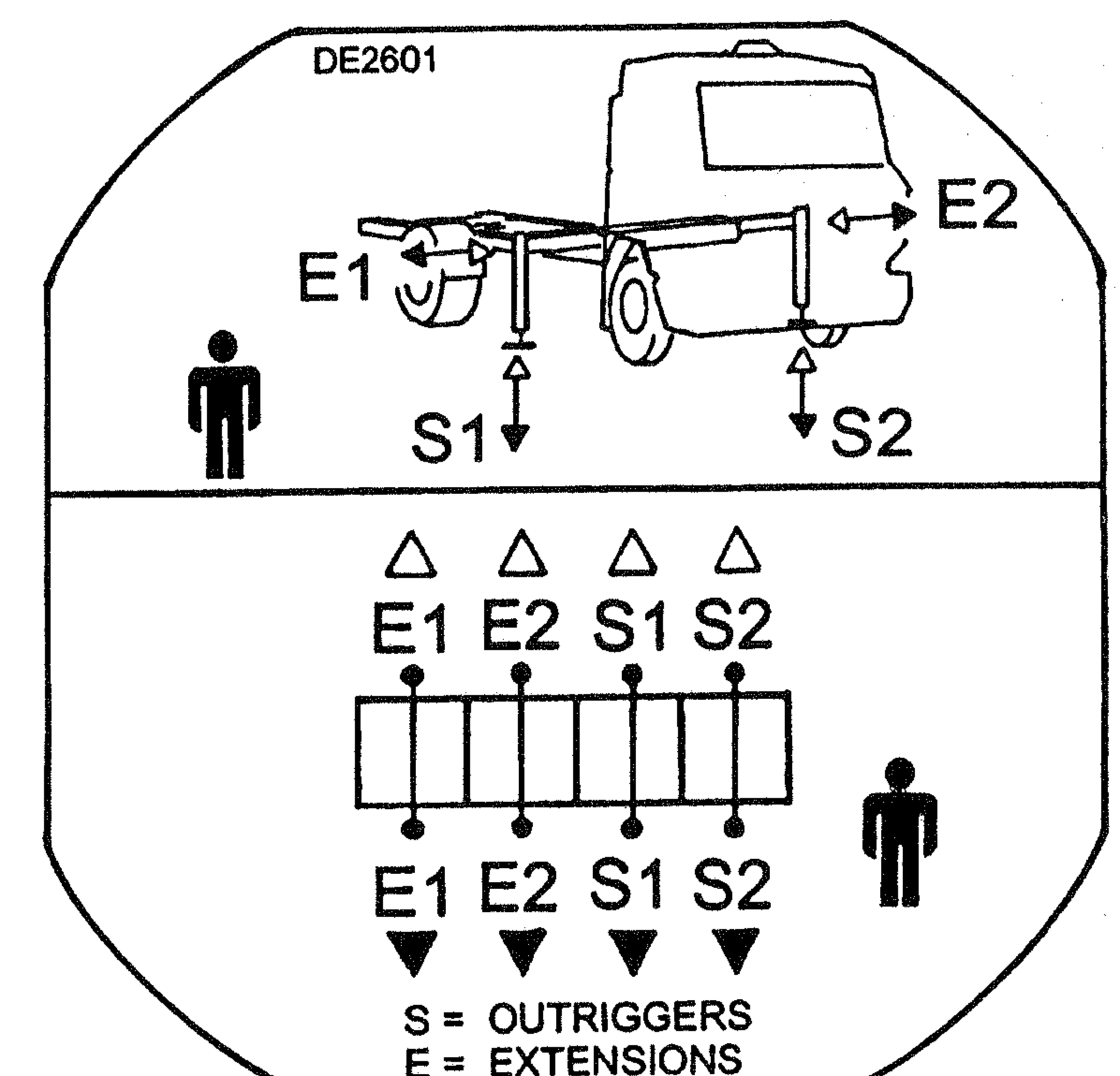

fig. 15

CONTROLS TO OPERATE THE CRANE

(!) WARNING (!)

Before operating the crane it is compulsory to set the outriggers.

This coincides with that indicated on the plate **DE2327** placed on the outriggers (Fig. 16)

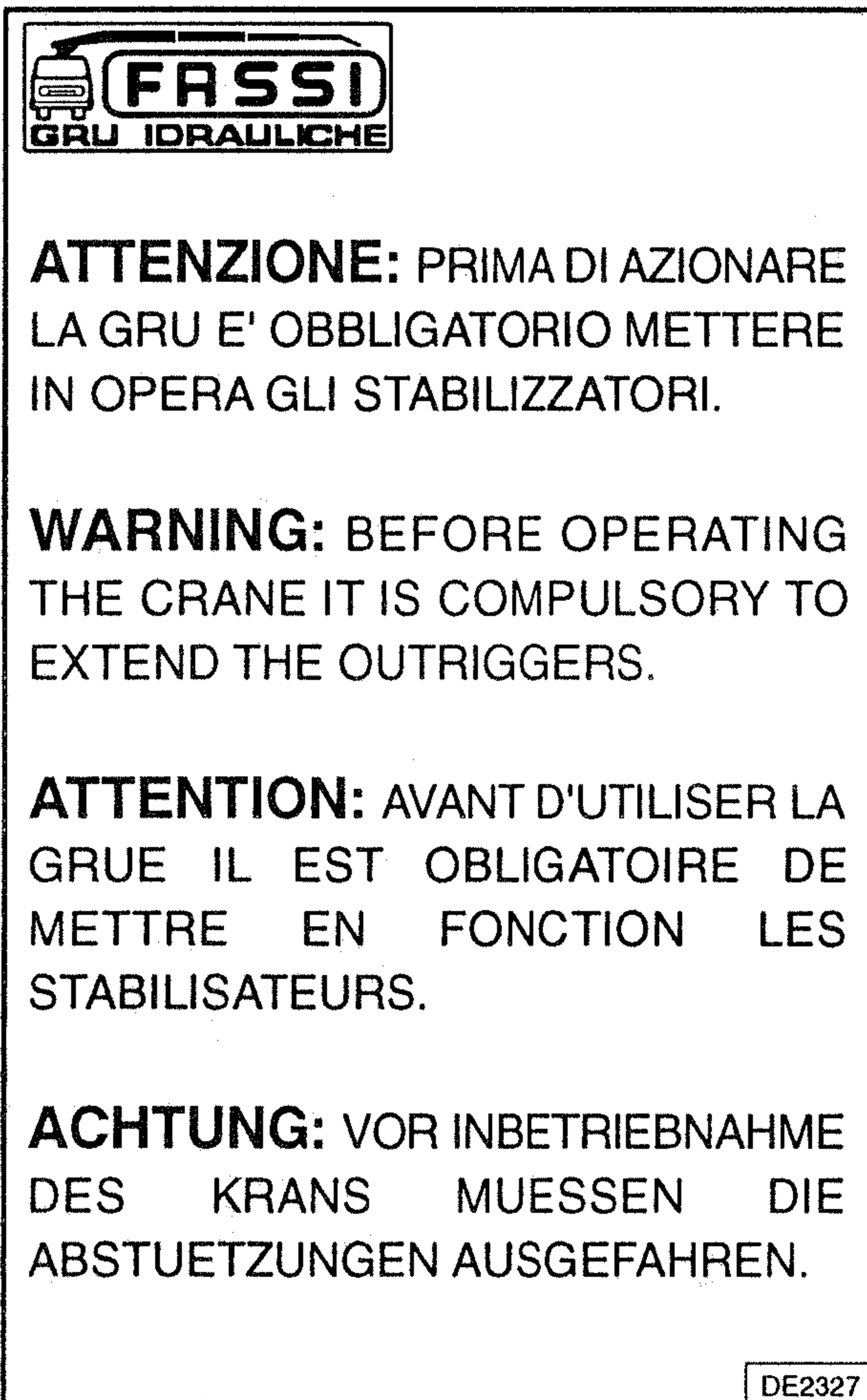

fig. 16

- (!) Operate the levers smoothly and gradually.
When carrying out simultaneous movements of two or more functions, it is possible that on reaching the stroke end of a particular function, an increase in speed of the other functions will occur.
- (!) The device indicating the operator presence which is fitted on the seat of the control station prevents the activation of the hydraulic working of the two distributors before the operator sits down at the control station.

The control station is on the top seat, the crane and the hydraulic implements are activated from the distributors, which are manually made by means of joystick (double function) and foot controls, placed on the left and right side of the operator.

The symbols on the plate **DE2868**, placed on the support handle in front of the operator, identify the left and right side of the control station and define the function of the joy-stick and foot controls in relation to the movement to be effected (Fig. 17).

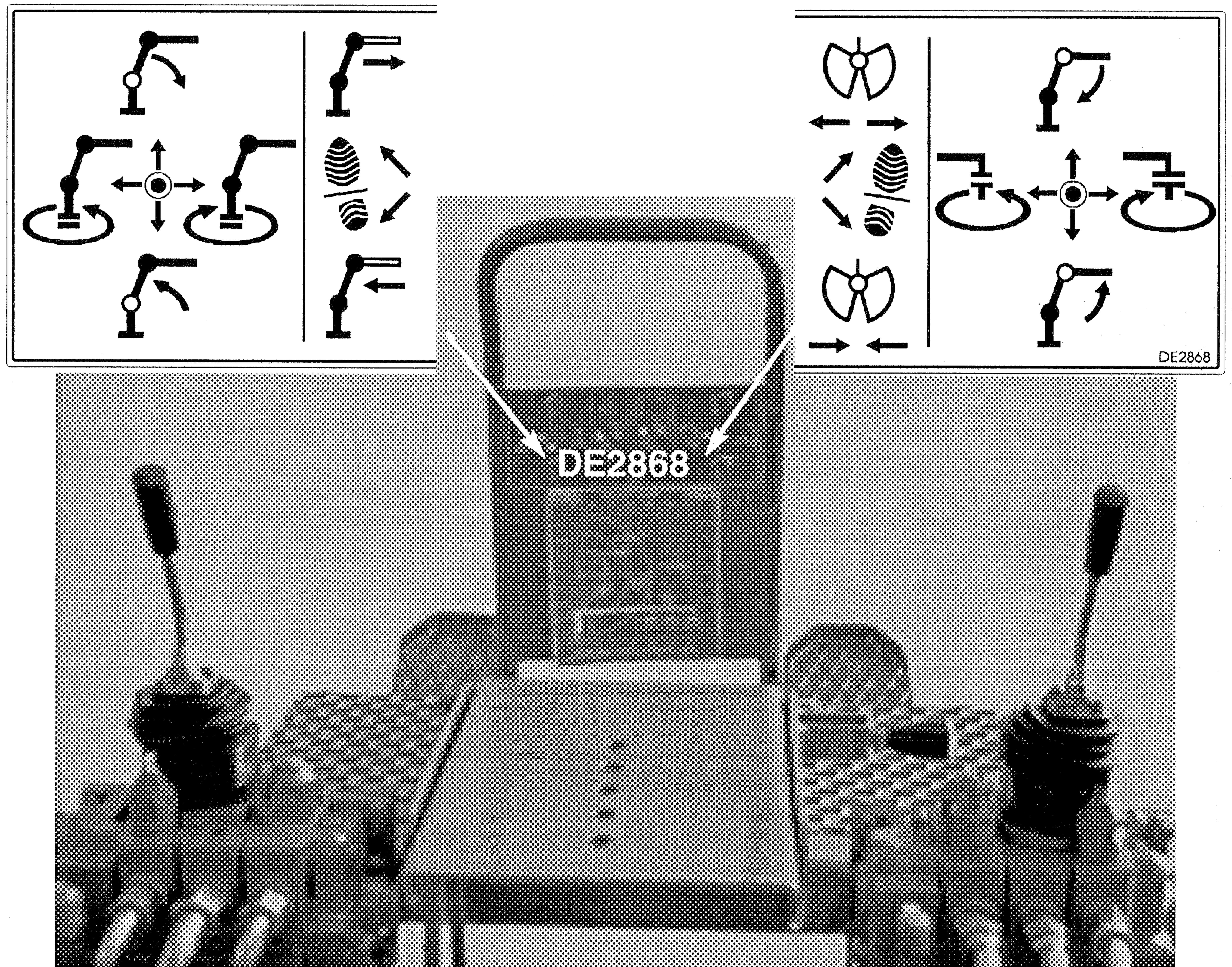

fig. 17

Left side of the control station

The left joy-stick controls the **inner boom** and the **rotation** of the crane;

- To direction of **backwards - forwards** operation, the inner boom moves:
in the position **forwards**, controlling the descent
in the position **towards**, controlling the ascent.

- To **right - left** direction, the crane **rotates**;
on the **right**: clockwise rotation
on the **left**: counterclockwise rotation.
- (!) Properly changing the angle of the operating direction of the joy-stick, it is possible to simultaneously control both functions.

The right foot control activates the **extension booms**;
Pushing with the feet tip, we control the boom extension exit
Pushing with the heel, we control the boom extension re-entering.

Right side of the control station

The right joy-stick controls the **outer boom** and the **rotator**

- To direction of **backwards - forwards** operation, the outer boom moves:
forwards, controlling the descent
towards, controlling the ascent.
- To **right - left** direction, the **rotator** moves.
on the **right**: clockwise rotation
on the **left**: counterclockwise rotation.
- (!) Properly changing the angle of the operating direction of the joy-stick, it is possible to simultaneously control both functions.

The right foot control activates the **pallet-fork**;
pushing with the feet tip, we control the opening of the pallet-fork.
pushing with the heel, we control the closure.

Manoeuvres to unfold the crane into a working condition

- Engage the power take off.
- Stabilize the vehicle as described on page .
- Before lifting the inner boom, be sure that the outer ram is open.
- Lift the inner boom over the horizontal line, close the outer boom and eventually extend the booms of the crane.
- Operate on the crane rotation to position the fork on the vertical line above the load, operate on the pallet-fork rotation control for the correct orientation of the fork.

Manoeuvres to fold the crane into the rest condition

- Open the outer boom to its stroke end.
- Re-enter the extension boom sections.
- Operate the rotation control of the crane and fold the inner boom, paying attention to the crane boom position on the body. It is necessary during this operation to orientate the pallet-fork position to avoid obstacles on the body or the load.
- Lift and re-enter the outriggers as previously described.
- Disengage the power take off.

- (!) **The fork must be tied down at all times during transport.**

Load manoeuvres

- (!) Before manoeuvring the load, verify that the working area is suitable for your crane.

The lifting curves of the capacity chart indicate the maximum load that the crane can lift at a certain radius and at a certain height.

- (!) **Always remember that when operating with implements, their tare weight must be deducted from the capacity of the crane.**

During load handling, do not exceed the reach limits given, or the load indicated on the above mentioned charts.

If the limits are exceeded, the lifting moment limiting device, allowing all manoeuvres, which reduce the lifted load within the permitted reach limits and forbid all other manoeuvres, will be immediately activated.

- (!) **The presence of the load limiting device does not release the user from the observance of the capacity chart.**

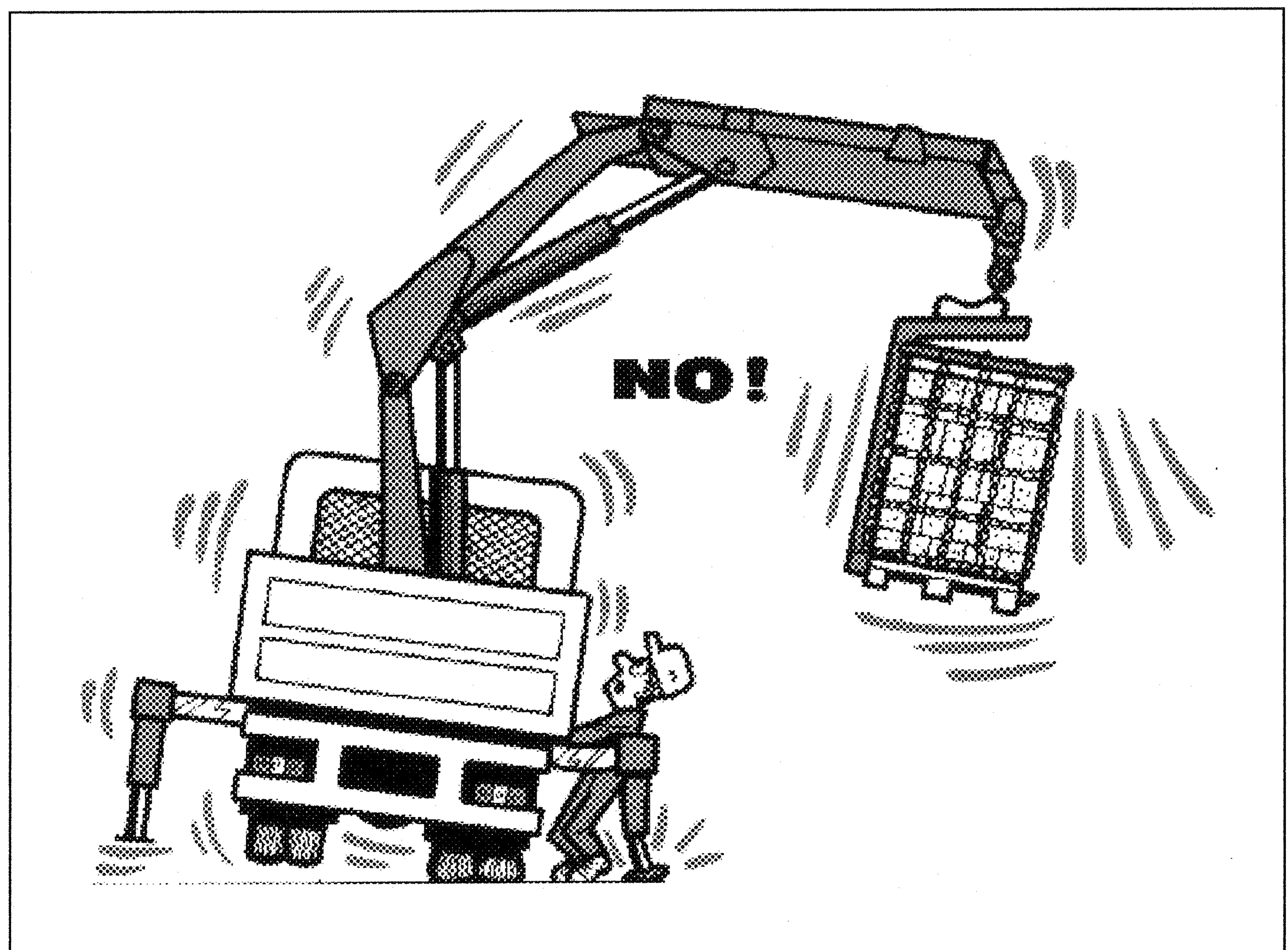

- (!) When using an implement it is always necessary to check that its weight, dimension and capacity is matched to the crane performances.

Warning and norms for crane use also apply for hydraulic implement use.

Always remember that when operating with implements, their tare weight must be deducted from the capacity of the crane.

Hydraulic connections between implements and hoses fitted on extension booms section.

- (!) In case of hoses connection to implements through coupling unions it is necessary to verify that there is no trace of soil, dirt etc. on the unions and inside the seats so as to avoid the oil contamination and consequently wear the tightening " surface of unions.

(!) WARNING (!)

To ensure that the control corresponds to the implement movement, hydraulic connections are symmetrically fitted with coupling unions. Never invert such positions: movements inversion as well as operating difficulties could occur.

MAINTENANCE INSTRUCTIONS

To assure a long life to the crane, it is necessary to meticulously follow the instructions.

General lubrication and small repairs can be carried out by the user; repairs of a more complicated nature must be carried out by authorized service personnel.

Spare parts must be original.

At least once a year you must take the crane to a Fassi Service Center for a check.

Good maintenance and proper use are imperative to maintain efficient use and guarantee the safety of the crane.

- (!) Before disconnecting any hydraulic hoses, ensure that there is no pressure in the hydraulic circuit. After removing hoses always mark them and their respective ports on the crane. Faulty replacement can cause damage to the rams and to the hydraulic circuit.

Respect the information supplied for maintenance and technical assistance.

Any maintenance operation must be carried out with the crane power source turned off. (in case of fixed mounting with hydraulic power pack, the electric motor has to be turned off).

Do not place limbs, fingers or any other parts of anatomy into areas of the crane, which present possibilities of shearing, without having blocked such parts of the crane.

Do not weld, drill or grind any part of the crane without the Manufacturer's authorisation.

fig. 18

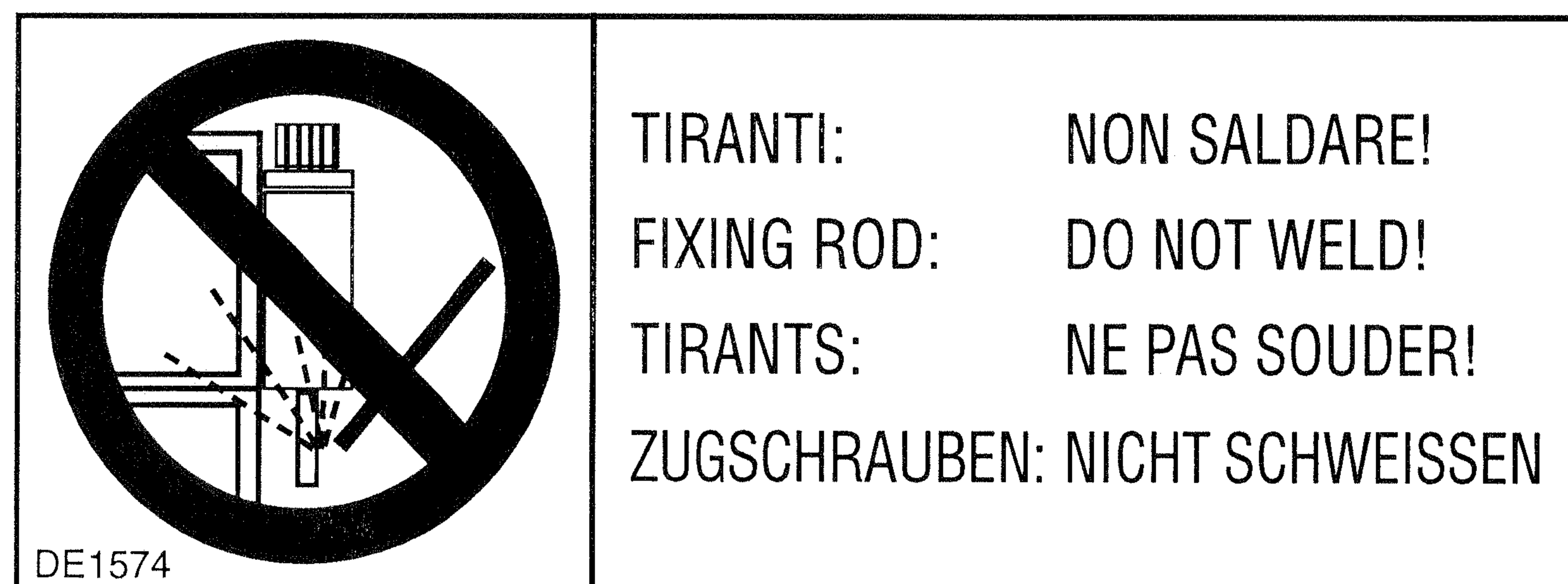

Do not weld the fixing rods of the crane (see plate DE1574 fig. 18)

When repairs to, or checks of, the hydraulic circuit and of the rams are carried out, it is very important not to use, or be in the proximity of, materials which can damage the circuit or contaminate the hydraulic oil eg. metal shavings, sand or dust.

Do not use the high pressure washing on the controls (deviators, distributors, double controls, hand cable controls...), on the electronic components (boxes, control panels...), on the tanks.

Never use detergents, petrolsol or inflammable liquids, always use non flammable or non toxic liquids.

To avoid down time, it is recommended to periodically carry out the following checks.

At the end of every working day

Check that all safety devices are efficient.

Check the level of the hydraulic oil in the tank.

Check the hoses fittings and all the components of the hydraulic circuit for possible leaks.

Check that the oil diverter levers  - **E/S** can easily be positioned.

Check that the crane controls (joy-stick and foot controls) and the outrigger controls (levers of the distributor and double control) can easily be positioned, operate freely and return to neutral position.

Check the condition of shackles, hooks, wire ropes and every eventually used equipment.

After the first 40 hours use

Check the tightening torque of the fixing rods of the crane. (Fig. 19)

Tightening torque for the rods M33x2 = 1200 Nm

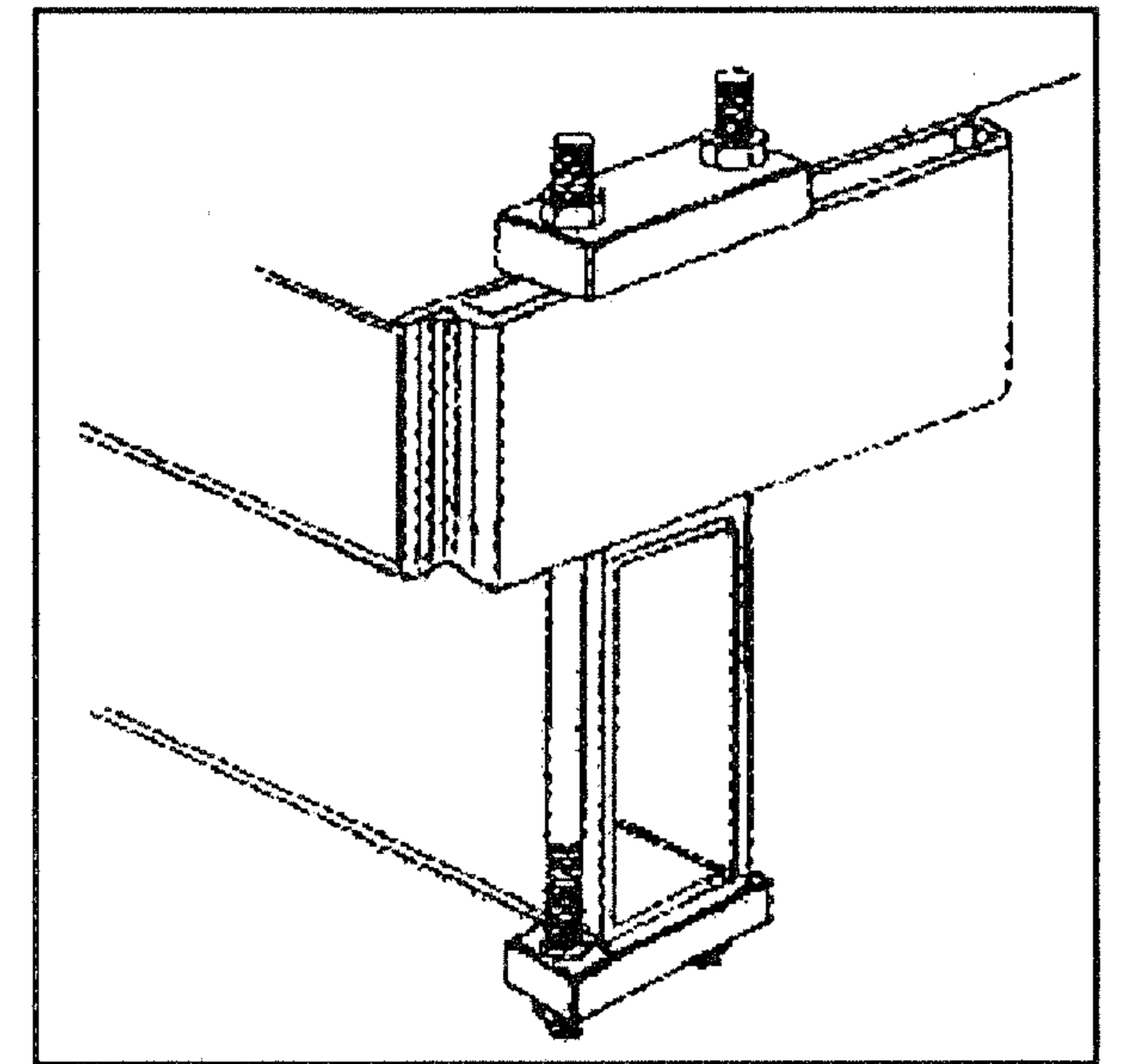

fig. 19

After every working week

Clean the oil filter placed in the oil tank of the crane and if any, on the pump section and pressure hoses.

Cleaning of the filter on the tank (oil return from the distributors) fig. 20

- Remove the filter cover, pos. 1, by unscrewing the three security bolts. Remove the spring and extract the filter cartridge pos. 2: during this operation take care that no contaminated material passes into the tank.
- Clean the cartridge by flushing with a non flammable and non toxic solvent. Thoroughly dry the filter inside and out with compressed air.
- Remove the filter holder from the filter body pos. 3 (a hose is attached to its base); clean and reassemble checking the sealing 'O' rings pos. 4-5 (internal seal between cartridge and holder and external seal between holder and body).
- Re-assemble the filter cartridge into its holder, re-assemble the spring and the filter cover pos. 6 (check the sealing of the 'O' ring under the filter cover).
- Re-fit the three security bolts.
- Check for leaks when the pump is activated.

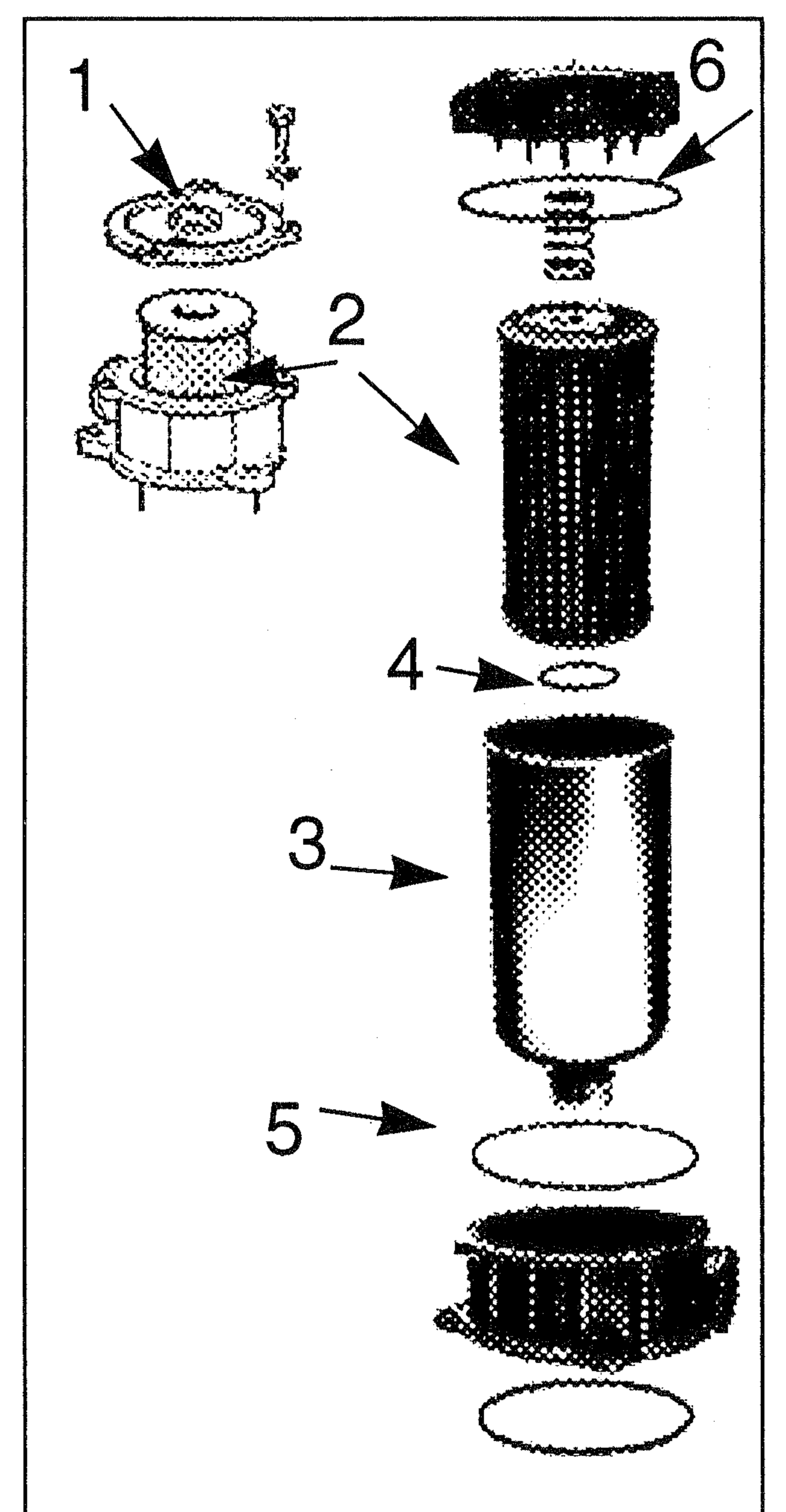

fig. 20

Check the oil level in the tank with the crane in the folded position and with the outriggers fully re-entered. The oil level must not exceed the maximum or be lower than the minimum (fig. 21).

Top up using hydraulic oil with the same characteristics as those indicated in the table on page 26

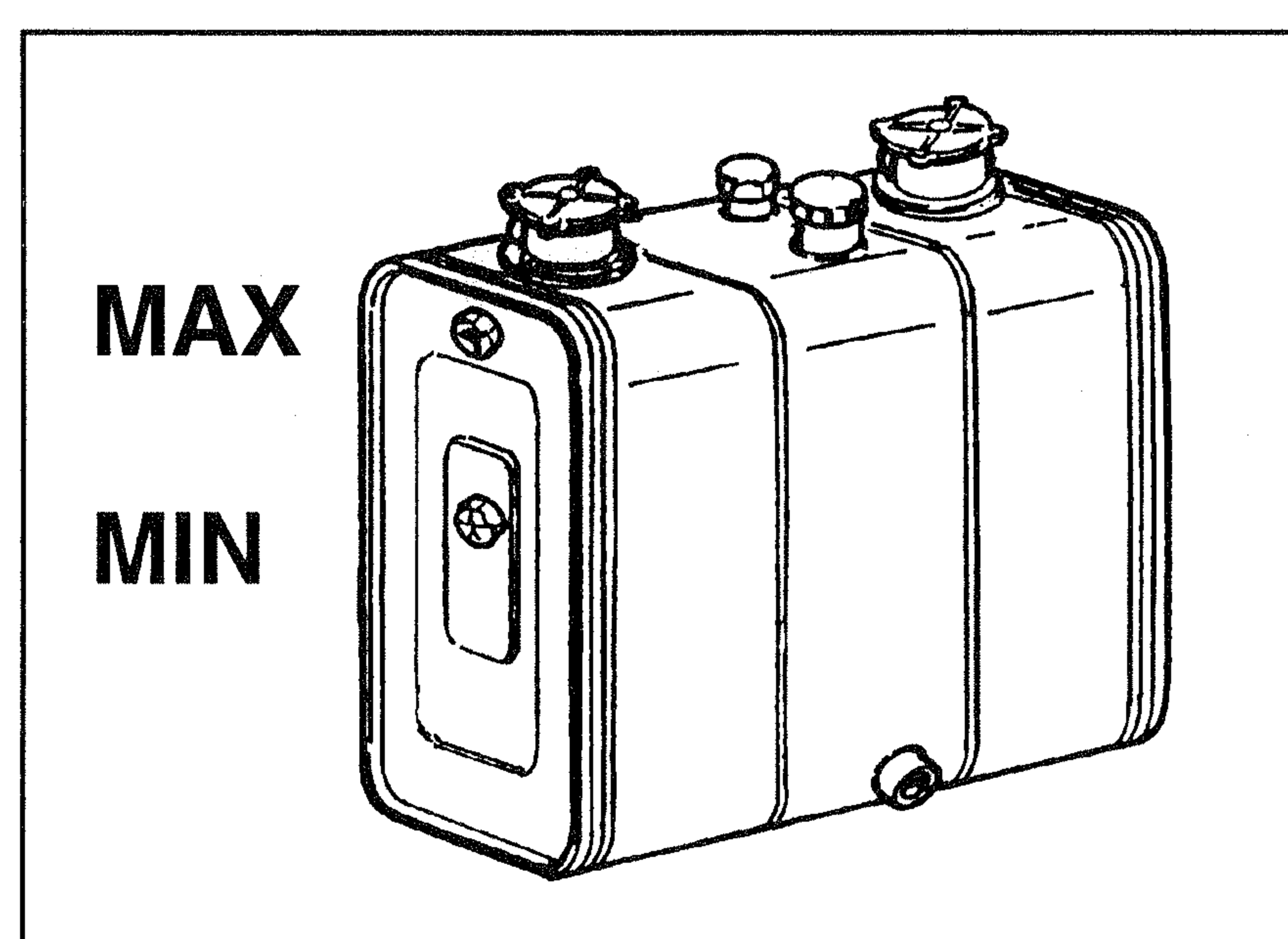

fig. 21

Periodically grease the points indicated on the fig. 22 paying particular attention to the points not easily detected.

A manifold permits to lubricate as well as possible the column rotation assembly, the rotation guide-shoe and the compensator.

For the sliding sections of the carter of the outer ram guide shoes have been fitted: to ease their movement it is recommended to smear a light film of grease on the guide-shoes.

For the sliding sections of the outrigger supports and of the extension booms guide shoes made from a special material have been fitted: to ease their movement it is recommended to smear a light film of grease on them, taking care that the surfaces of the outrigger supports and extension booms are free from impurities such as sand etc.

Use a grease with the same characteristics indicated in the table on page 26.

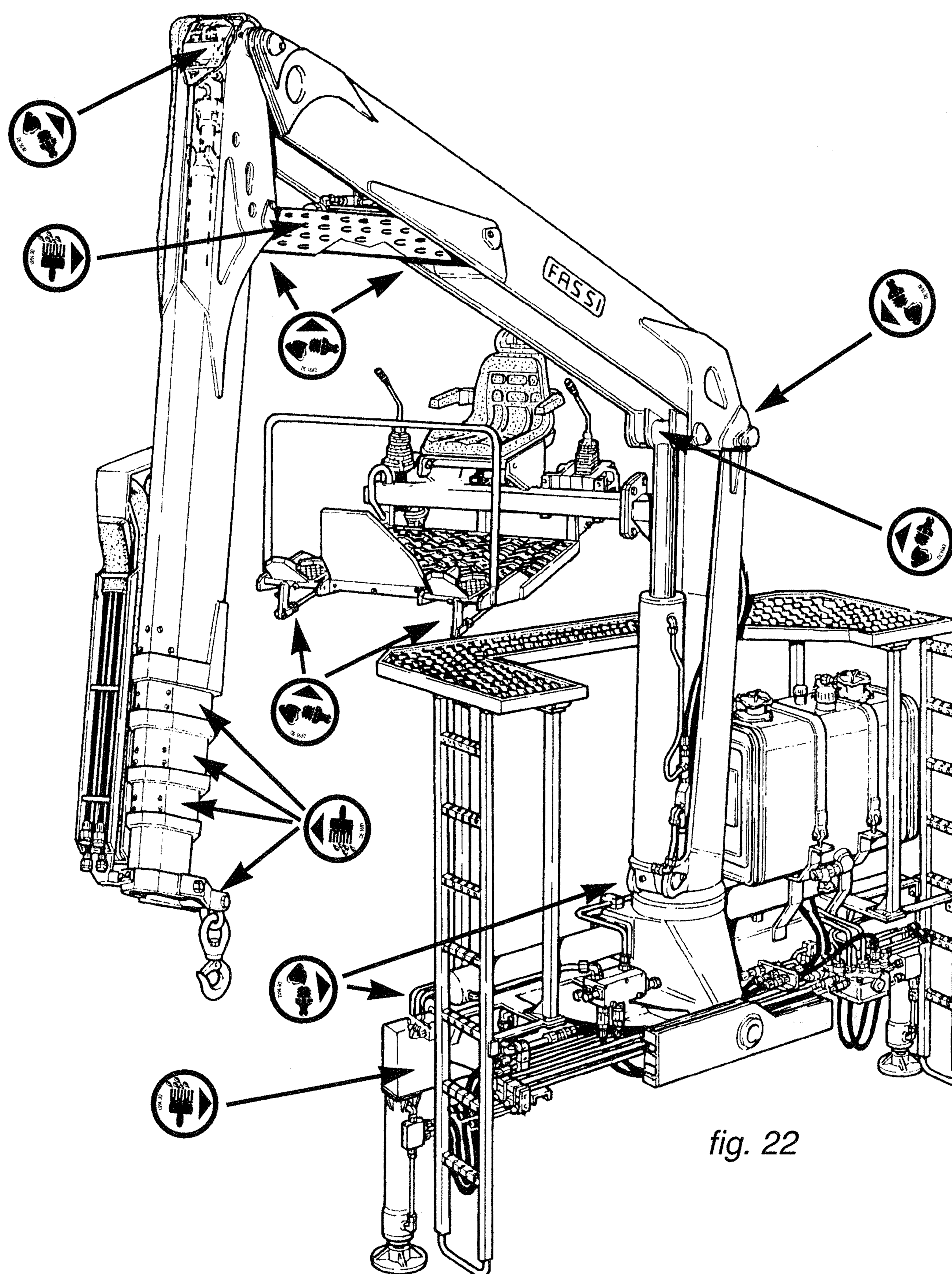

fig. 22

After every 500 working hours

Check the tightening torque of the tie rods fixing the crane to the vehicle frame.

Check the tightening torque of the securing bolts for the ram pins.

Check the guide shoe wear as it affects the sliding section tolerances; if the clearances are considerable, damage to the rams and the structure may occur.

Replace the oil filter cartridges.

Clean the air filter placed in the top of the oil tank filter cap.

Completely replace the hydraulic oil.

(!) The waste oil must be disposed of by authorized persons.

Many years experience of our product has allowed us to identify and classify the most common faults which occur. In most cases it requires accurate hydraulic and electric troubleshooting and simple rectification. In the following table we report the most frequent inconveniences and our suggested remedies.

(!) Checking and adjustment of oil pressures of valve settings must be carried out by an authorized service agent, under penalty of warranty forfeiture.

Operations which can be carried out by the user.

Faults	Cause	Remedies
The crane does not rotate properly	<i>Vehicle non in level position</i> <i>Lack of lubrication</i>	Stabilize the vehicle Grease the bushes
The extension booms do not completely extend or work jerkily	<i>Lack of lubrication of the guide shoes</i>	Grease the guide shoes
Crane controls are not active when the operator is at the control station	<i>Lack of electric energy</i> <i>The device indicating the operator presence on the top seat is activated</i>	Check the fuse, the battery and electric circuit Check the circuit of the device indicating the operator presence on the top seat
Vibrations in crane operations	<i>Shortage of oil</i> <i>Obstructed filters</i>	Check the level and top up if necessary Clean or replace the filter cartridge
Noteable decrease in movement speed	<i>Obstructed filters</i>	Clean or replace the filter cartridge

Operations to be carried out by a service center.

Faults	Cause	Remedies
The crane does not lift the loads indicated on the capacity plate	<i>Non efficiency of the pump</i> <i>Main pressure valve not properly adjusted, blocked or out of service</i> <i>Ram seals are not properly fitted</i>	Replace the pump Check the pressure, adjust the valve Replace the seals
A boom of the crane does not hold up the load and visually lowers	<i>The safety check valve of the ram is open</i> <i>Oil leaks inside the ram</i>	Replace the valve Defective seals, replace them
The crane does not rotate properly	<i>Valves controlling the rotation not adjusted</i> <i>Wear of the seals of the rotation cylinder</i>	Adjust the valves Replace the seals
The extension booms do not completely extend or work jerkily	<i>Wear of guide shoes</i>	Check the guide shoes wear, replace if necessary
Vibrations in crane operations	<i>Non efficient pump</i>	Check the pump
Noteable decrease in movement speed	<i>Non efficient pump</i>	Check the pump

HYDRAULIC SCHEMATICS

Hydraulic schematic for crane - two distributor Salami - lifting moment limiting device "intelligent" type

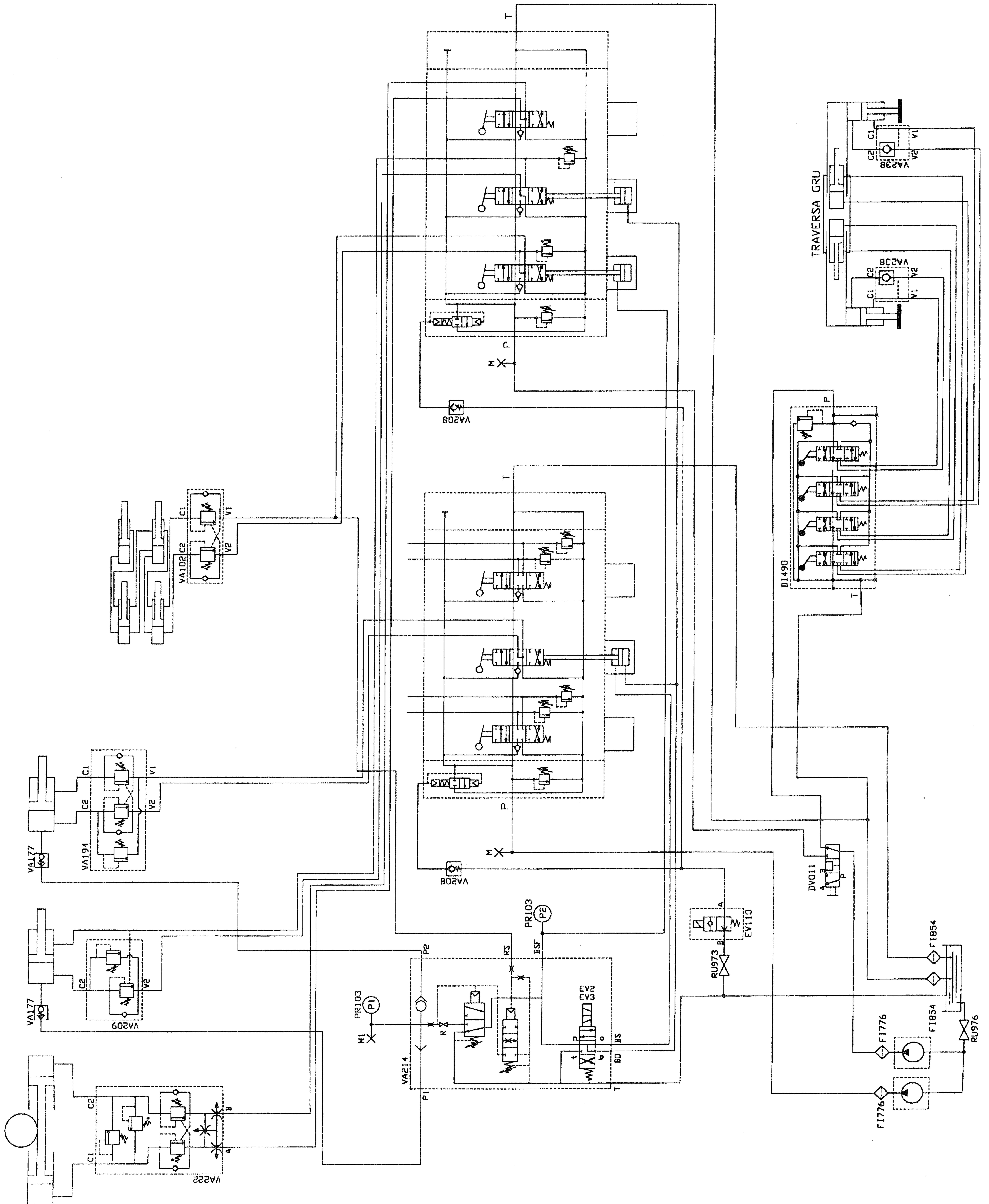

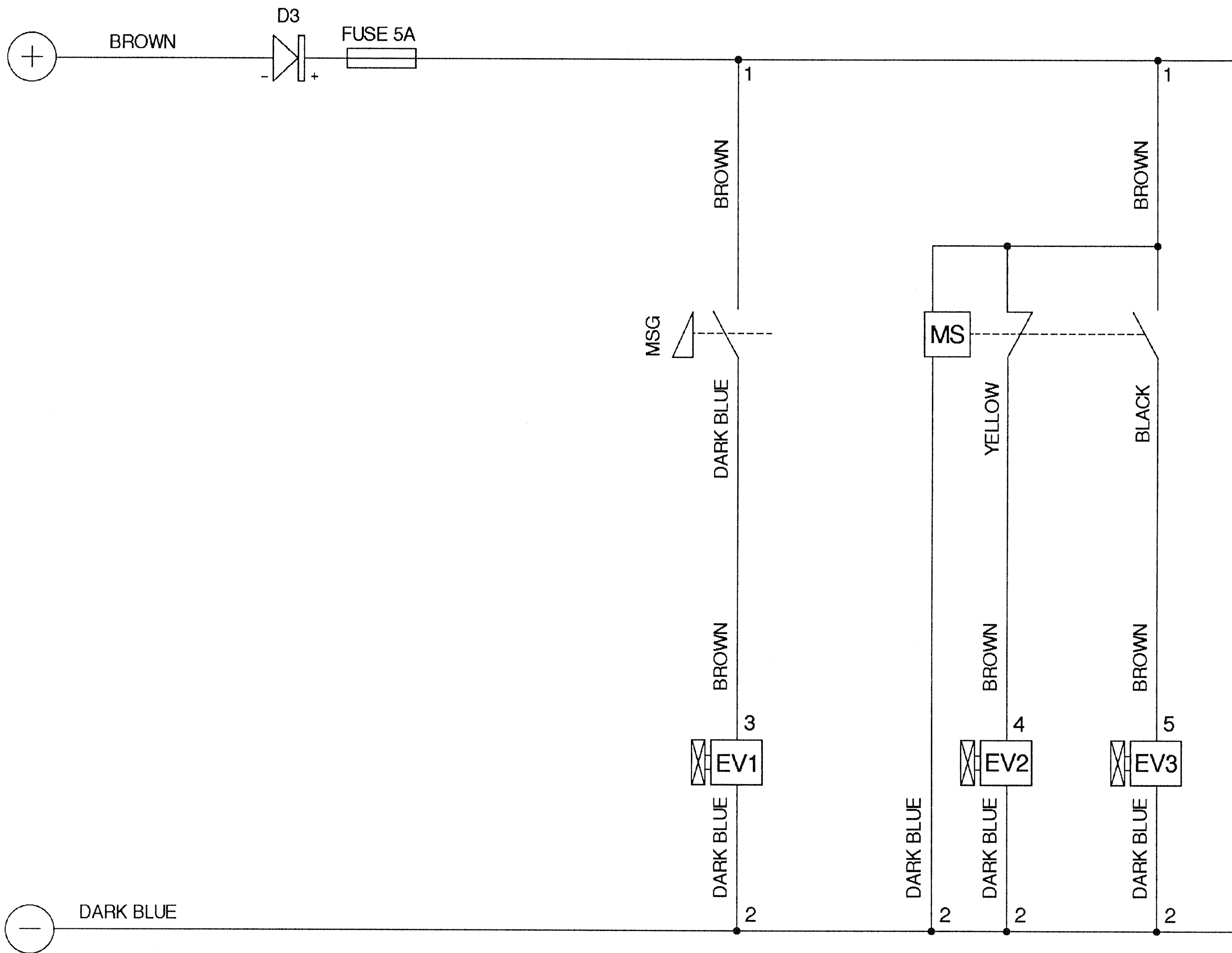

CODE	DESCRIPTION
ALIM	FEED GENERAL CONTROL PANEL
FUSE	PROTECTION FUSE 5A
D1	POLARITY PROTECTION DIODE
EV1	EMERGENCY ELECTROVALVE
EV2	ELECTROVALVE FOR LIFTING BLOCK LIMITING DEVICE
EV3	ELECTROVALVE FOR DESCENT BLOCK LIMITING DEVICE
MS	MERCURY SLOPE SENSORS ON OUTER BOOM
MSG	SEAT SAFETY MICRO

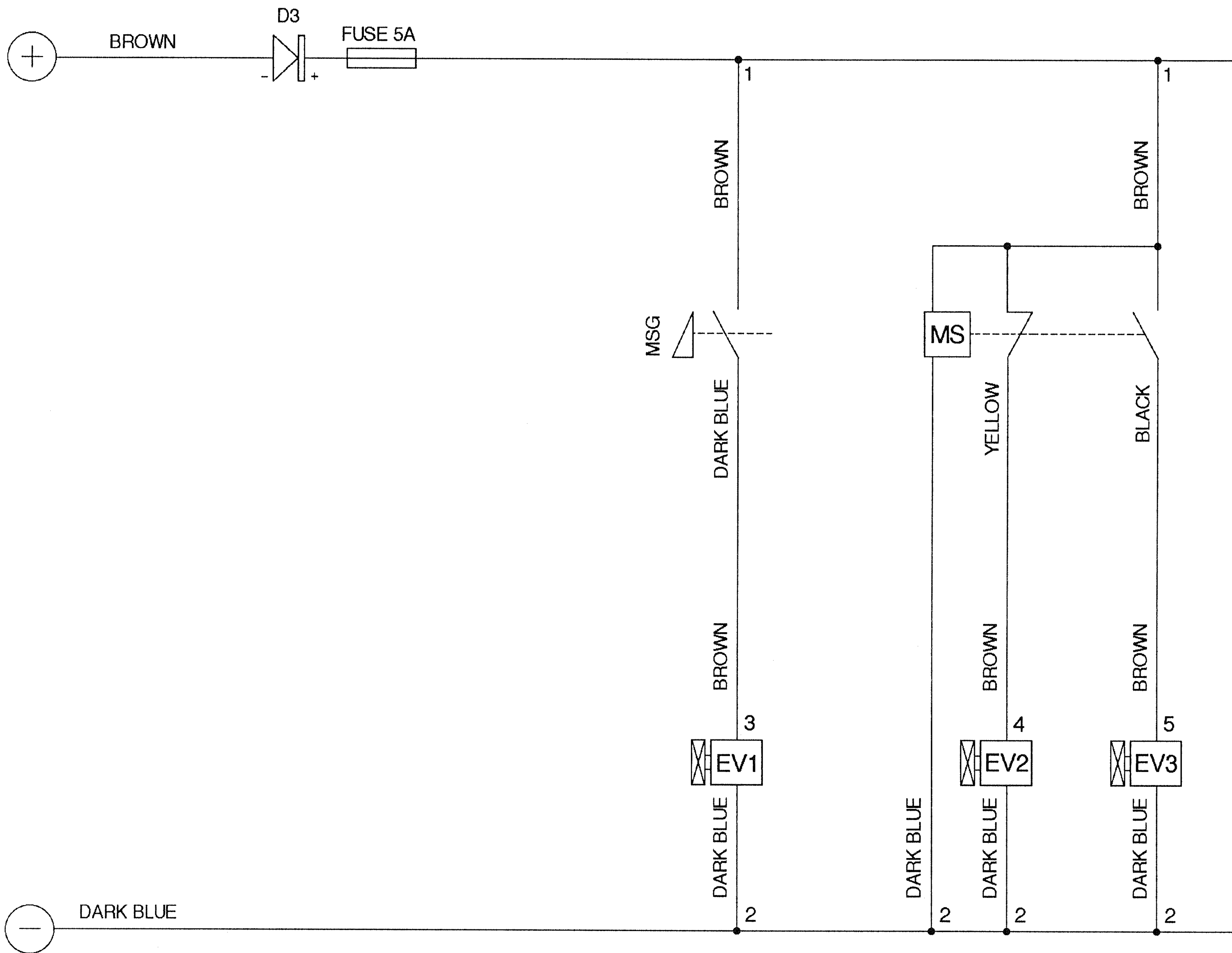

CODE	DESCRIPTION
ALIM	FEED GENERAL CONTROL PANEL
FUSE	PROTECTION FUSE 5A
D1	POLARITY PROTECTION DIODE
EV1	EMERGENCY ELECTROVALVE
EV2	ELECTROVALVE FOR LIFTING BLOCK LIMITING DEVICE
EV3	ELECTROVALVE FOR DESCENT BLOCK LIMITING DEVICE
MS	MERCURY SLOPE SENSORS ON OUTER BOOM
MSG	SEAT SAFETY MICRO

TABLE OF HYDRAULIC OIL AND LUBRICANTS CHARACTERISTICS

HYDRAULIC OIL WITH HIGH VISCOSITY: ISO-L-HV

Minimal external temperature :	maximal oil temperature:		
- 35°C	+ 45°C	Gradation	ISO VG 32
- 20°C	+ 75°C	Gradation	ISO VG 46

HYDRAULIC OIL WEAR RESISTANT: ISO-L-HM

Minimal external temperature :	maximal oil temperature:		
-10°C	+ 60°C	Gradation	ISO VG 32
+ 0°C	+ 75°C	Gradation	ISO VG 46
+ 5°C	+ 85°C	Gradation	ISO VG 68
+10°C	+ 90°C	Gradation	ISO VG 100

GREASE

Consistency: NLGI BEACON EP 2 - BEACON 3

(!) WARNING (!)

Don't use greases with solid particles as "Bisulphide of Molybdenum".



FASSI GRU IDRAULICHE SpA
24021 ALBINO (BG) ITALY - Via dei Carmelitani, 2
Tel. + 39 35 77.64.00 - Fax + 39 35 75.50.20

INSTRUCTIONS FOR SAFE USE OF THE CRANE

DE2676

- 1 Only authorized persons are permitted to operate the crane.
- 2 The crane must be used on firm, level ground.
- 3 Check that the vehicle hand brake is on and that the wheels are chocked.
- 4 Before operation make sure that:
 - no-one is within the working area of the crane;
 - the safety devices are in place and operative;
 - the minimum safe working distances from power lines are observed;
 - the load is correctly slung and hooked.
- 5 Stabilize the vehicle with the outriggers, making sure that:
 - the lateral supports are fully extended;
 - the wheels are in contact with the ground and the suspension is not completely unloaded;
- 6 Use the crane in accordance with the use and maintenance manual, making sure that:
 - the load and radius are within the maximum limits shown on the crane capacity plate;
 - the crane is used progressively avoiding sudden load movements;
 - swinging or dragging of the load is avoided;
 - the load is lifted before rotating.
- 7 When using implements protect the working area with a barrier.
- 8 The vehicle/crane are not left unless the power take off is disengaged and the load is on the ground.
- 9 Before driving the vehicle ensure that the outriggers are fully retracted and re-entered and the crane is in the folded position.

DE 2676

Instruction plate and safety norms



ATTENZIONE: PRIMA DI AZIONARE LA GRU E' OBBLIGATORIO METTERE IN OPERA GLI STABILIZZATORI.

WARNING: BEFORE OPERATING THE CRANE IT IS COMPULSORY TO EXTEND THE OUTRIGGERS.

ATTENTION: AVANT D'UTILISER LA GRUE IL EST OBLIGATOIRE DE METTRE EN FONCTION LES STABILISATEURS.

ACHTUNG: VOR INBETRIEBNAHME DES KRANS MUESSEN DIE ABSTUETZUNGEN AUSGEFAHREN.

DE2327

DE 2327

Warning plate to stabilize the vehicle before using the crane

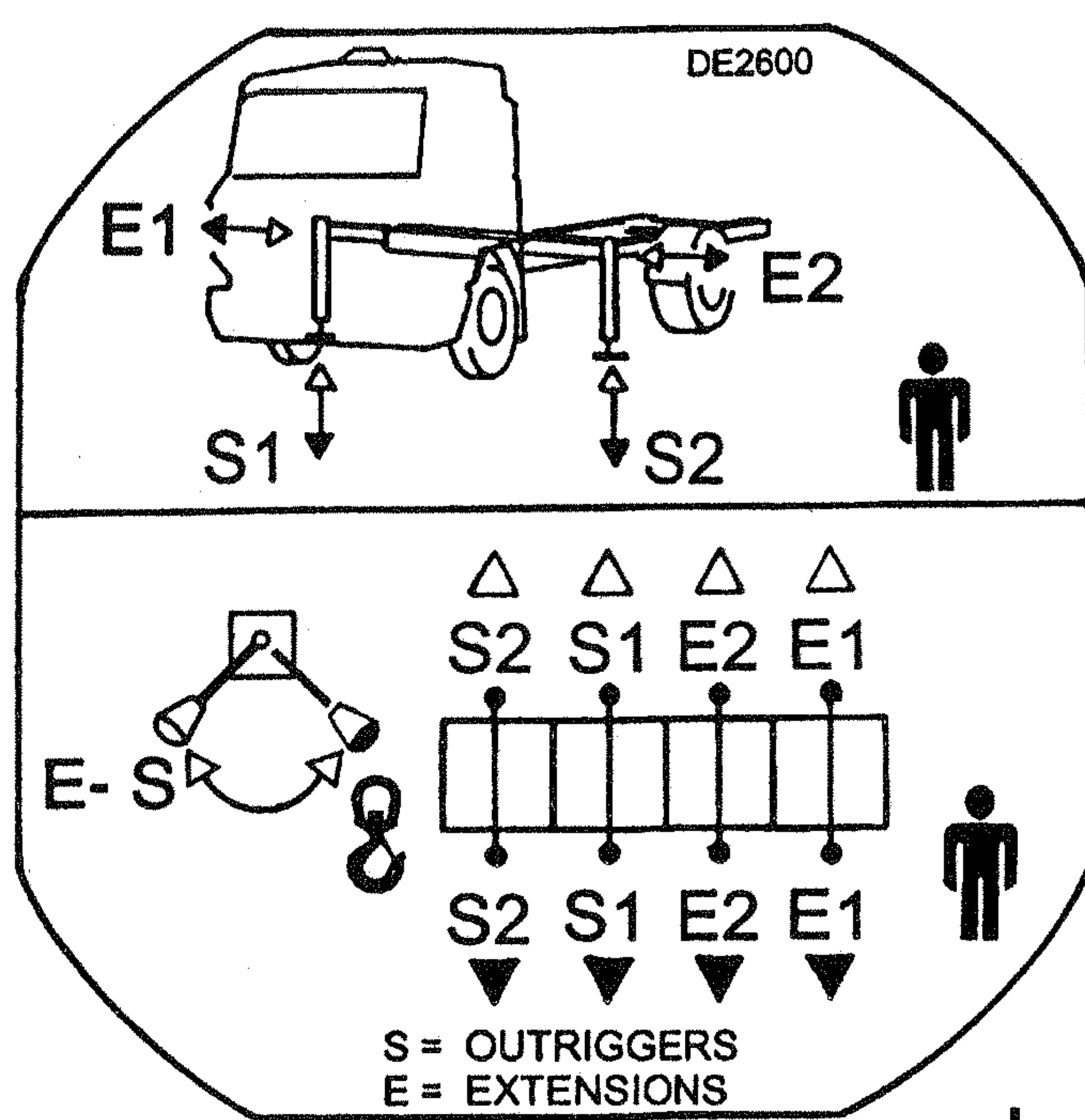

DE 2600

Instruction plates to stabilize the vehicle

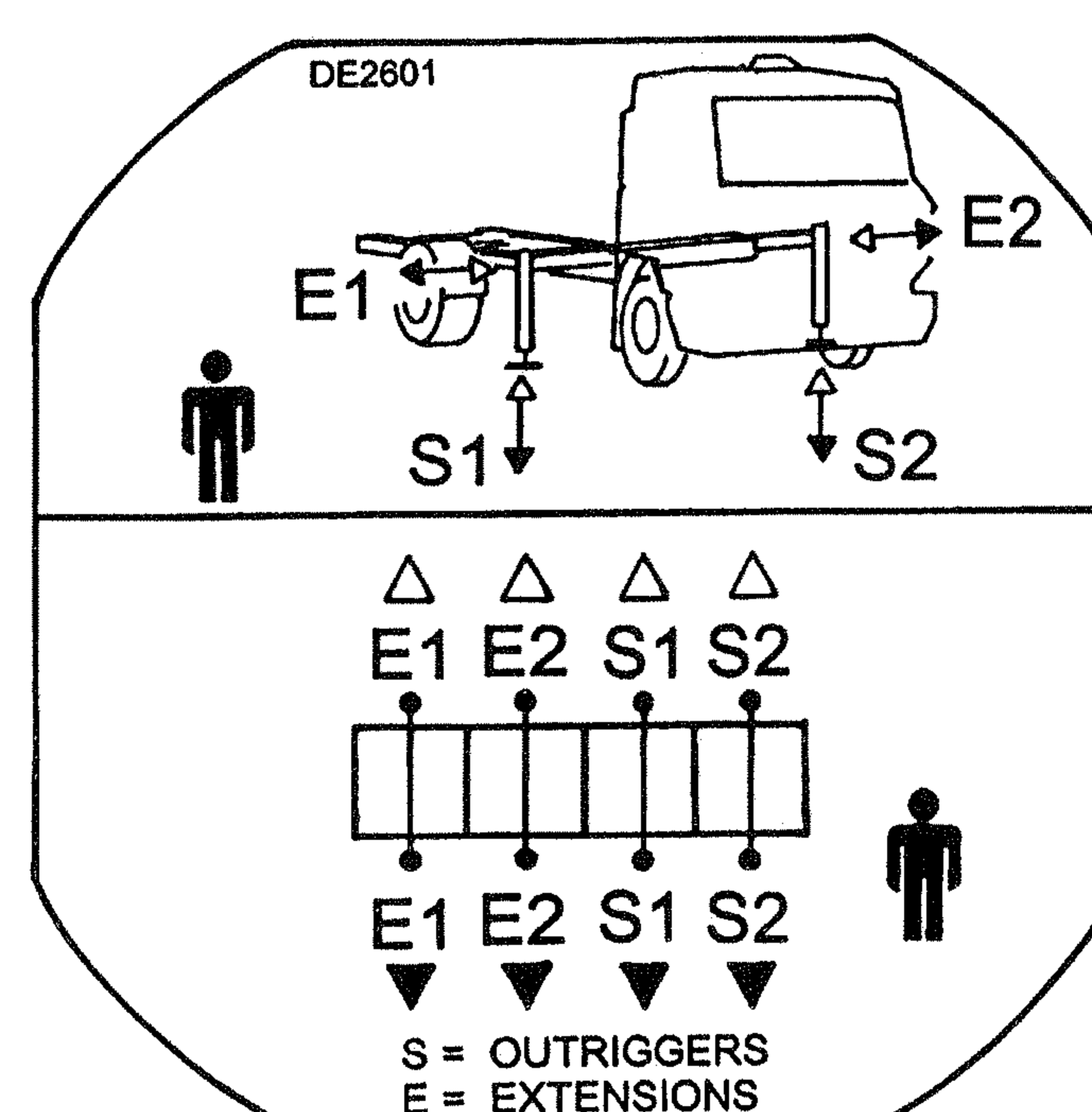

DE 2601

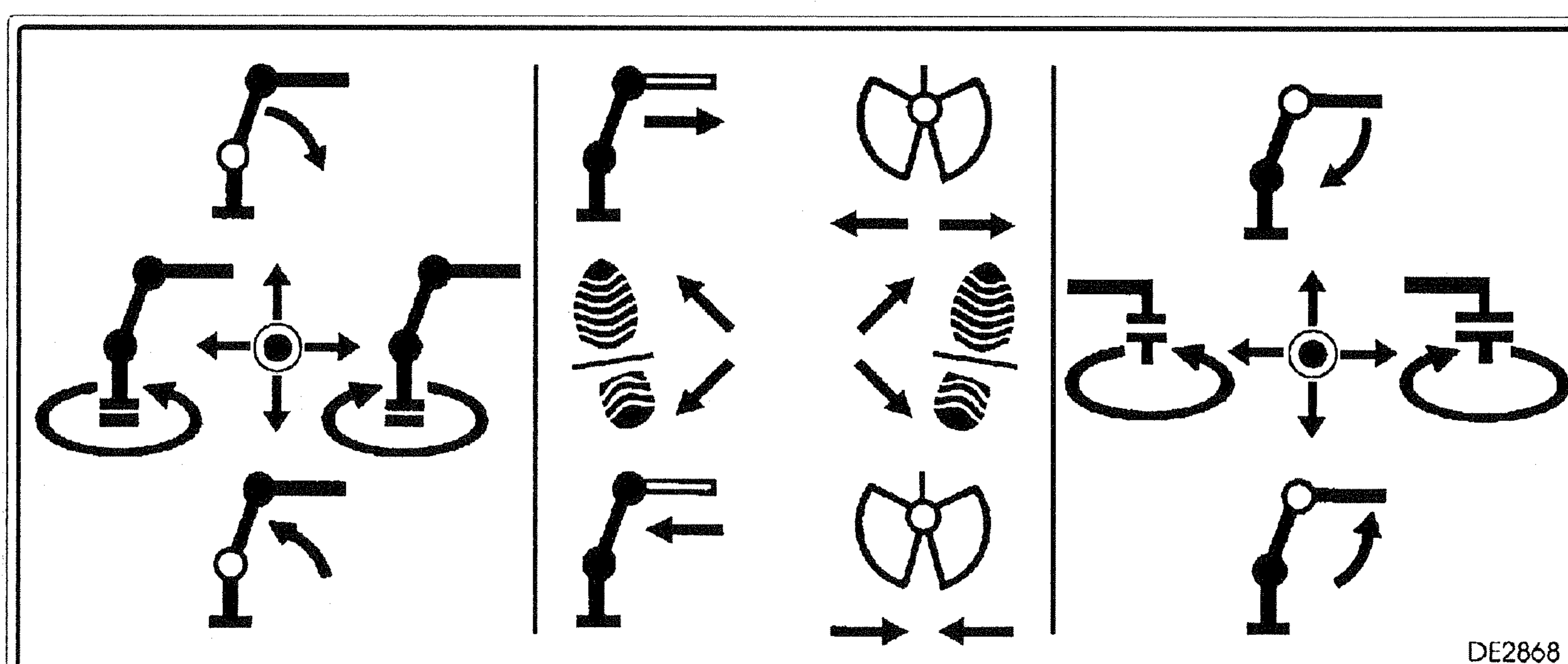

DE2868

DE 2868

Crane controls plate



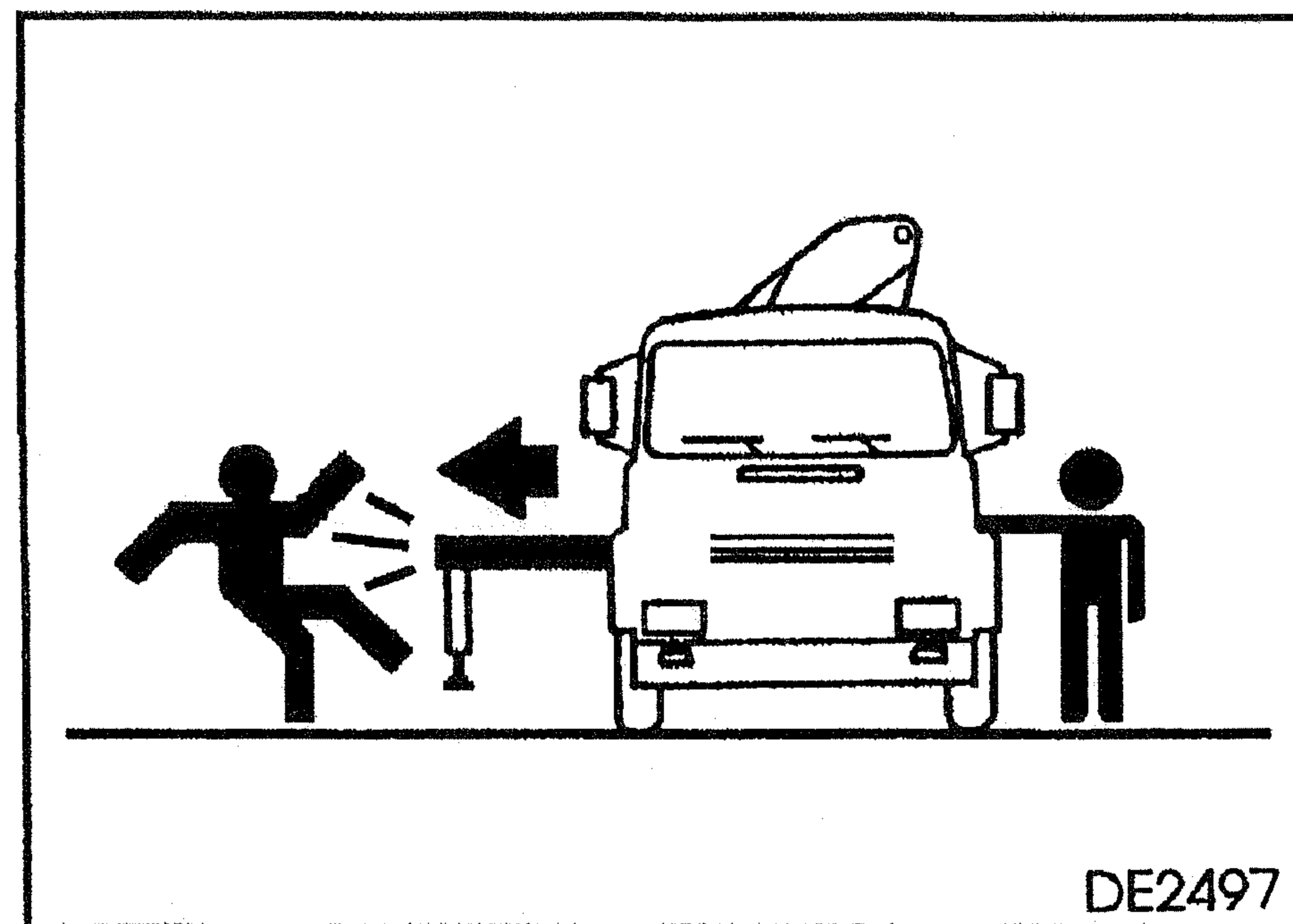

DE2497

DE 2497

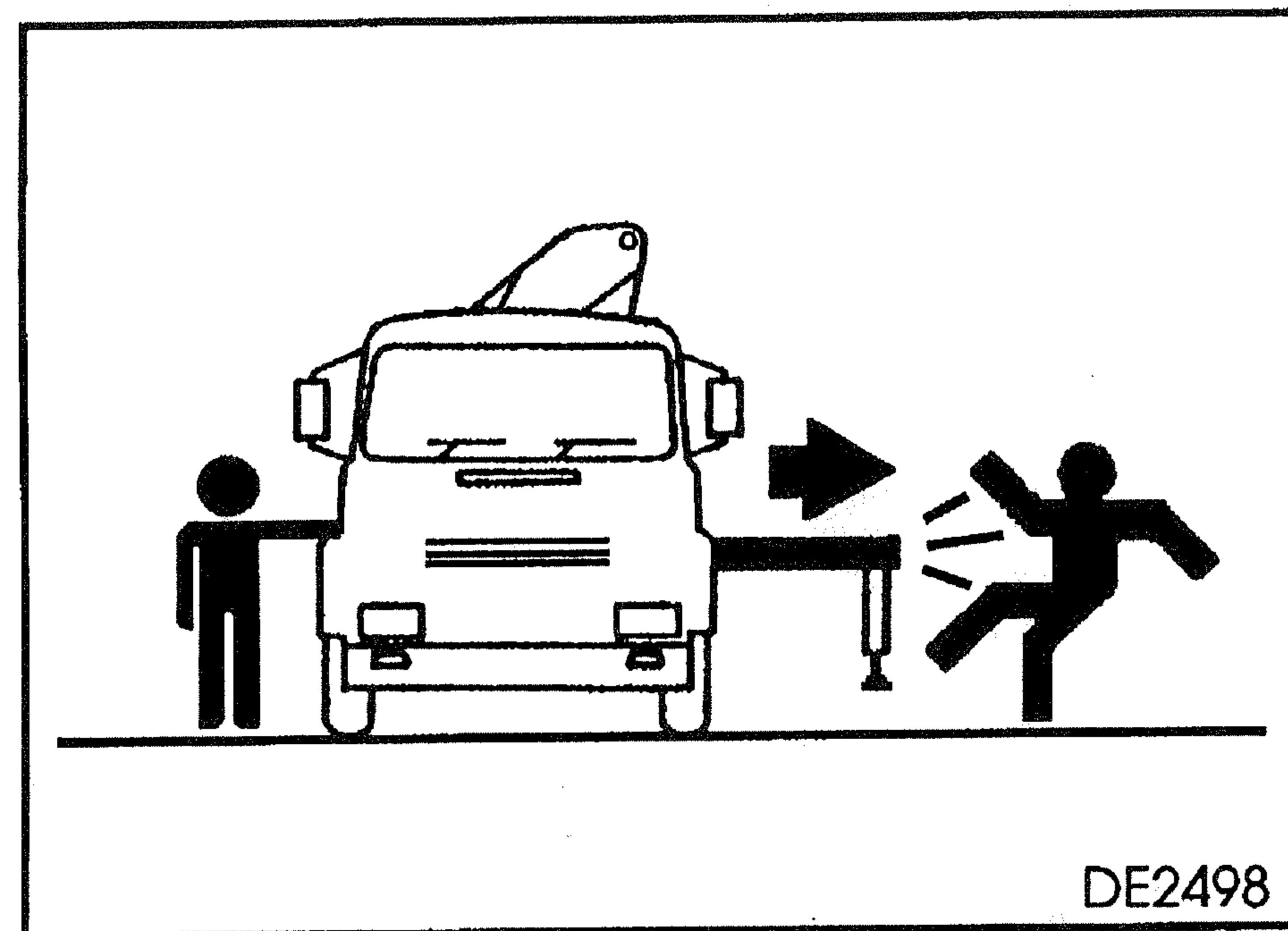

DE2498

DE 2498

Warning plates to make sure that no one is or transits in close proximity of the outriggers

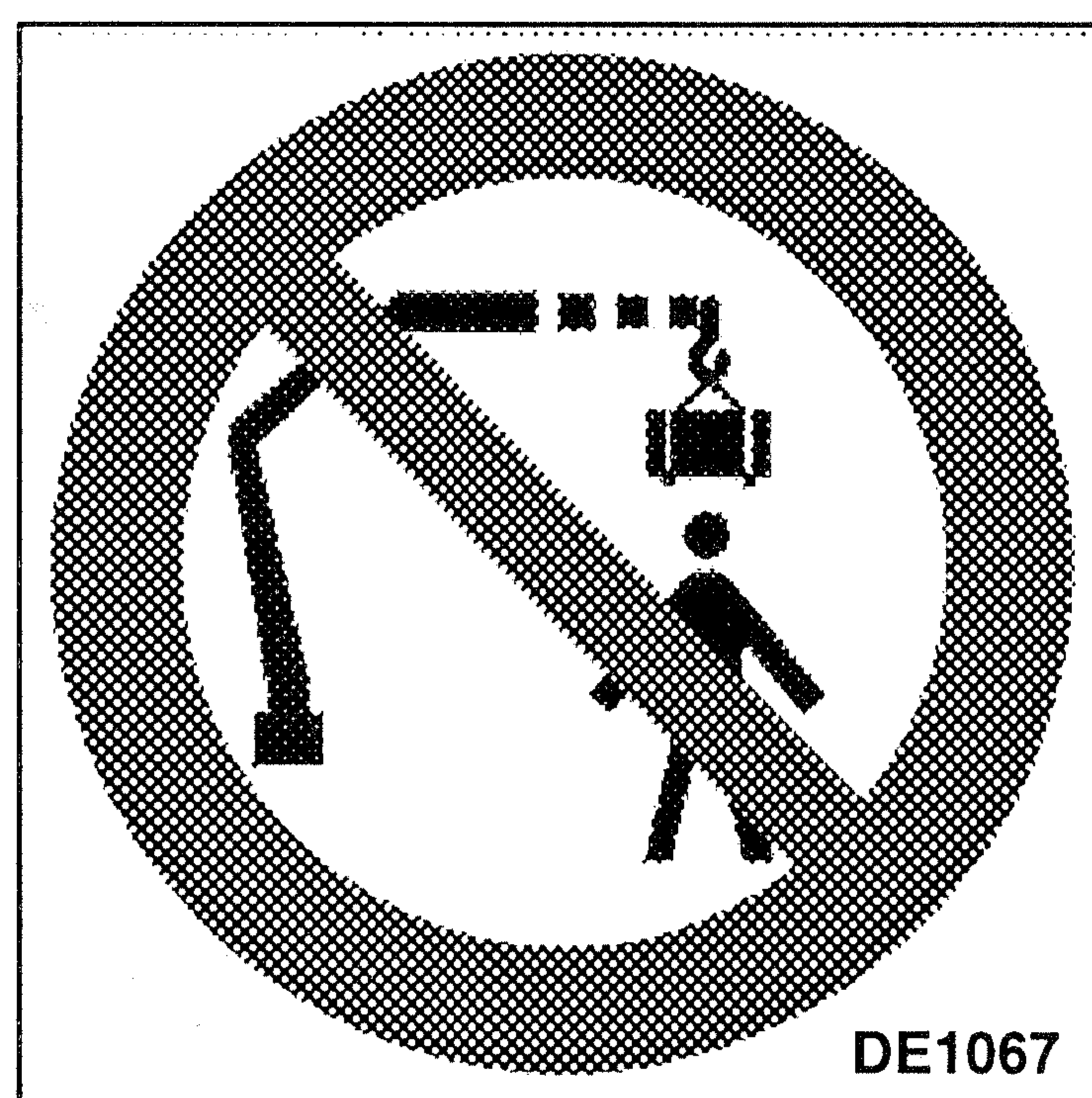

DE1067

DE 1067

Do not walk or stay under a suspended load and for unauthorized persons to be within the working area.

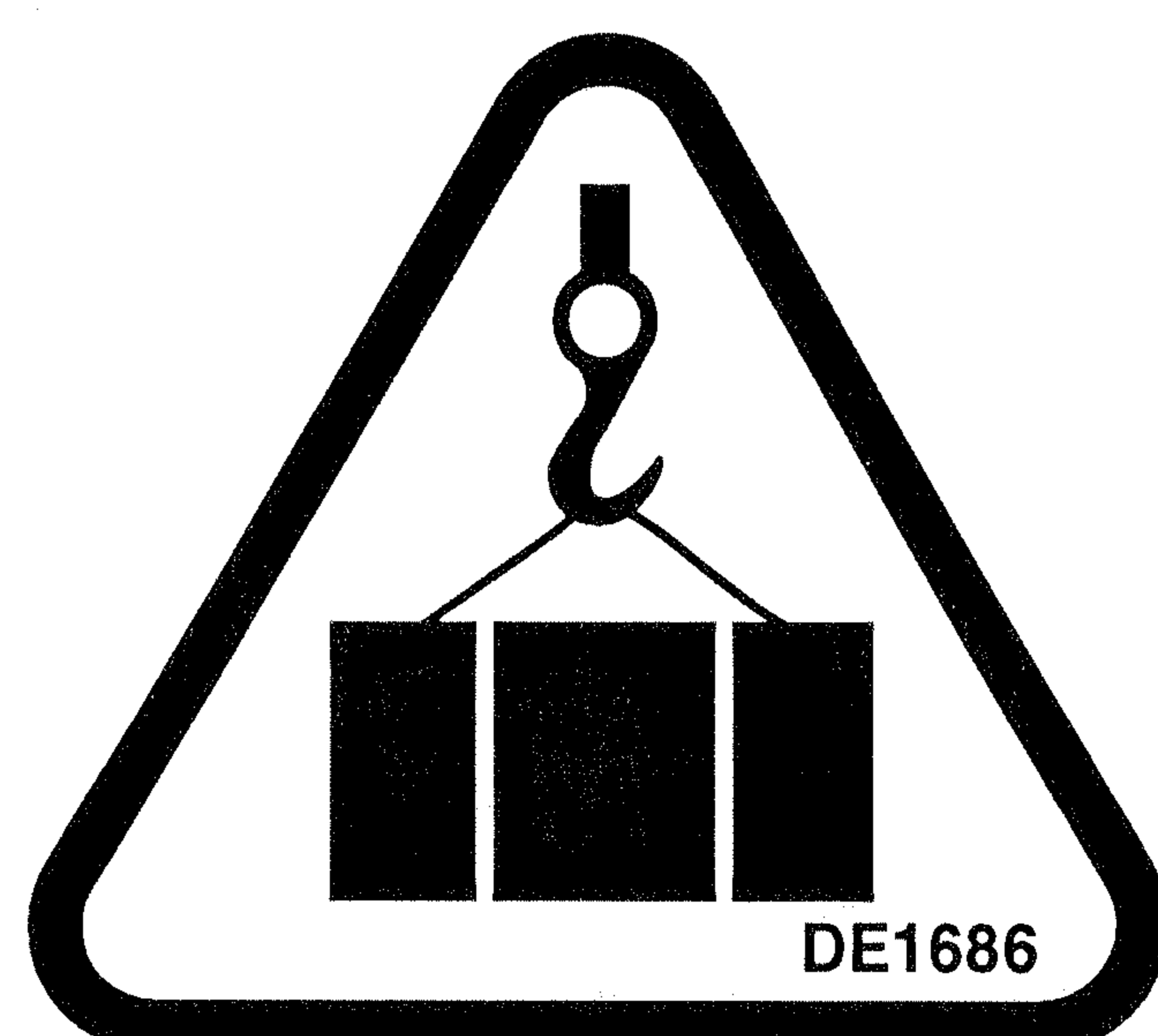

DE1686

DE 1686

Do not walk or stop under a suspended load

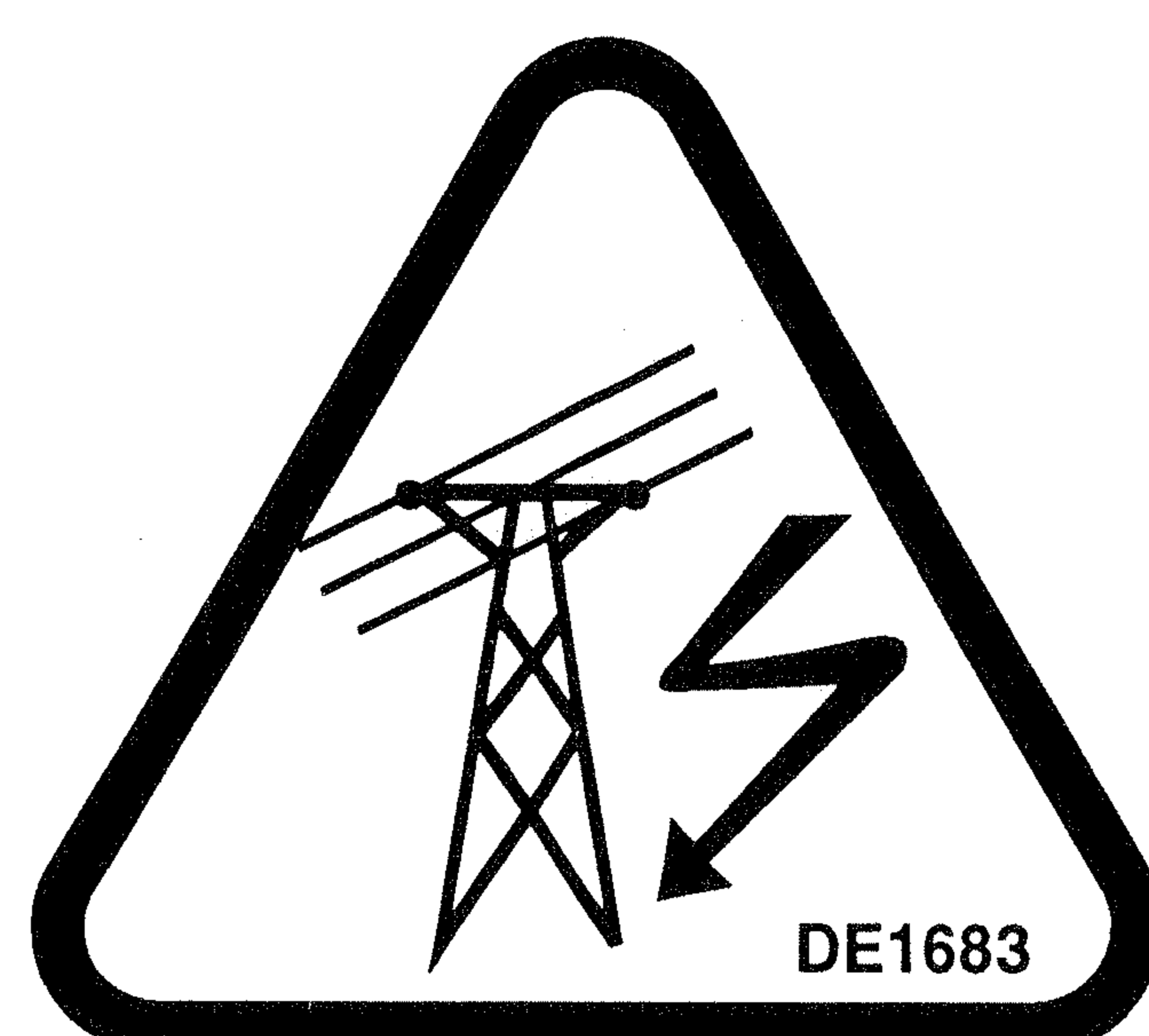

DE1683

DE 1683

Do not operate in proximity of electric high-tension lines

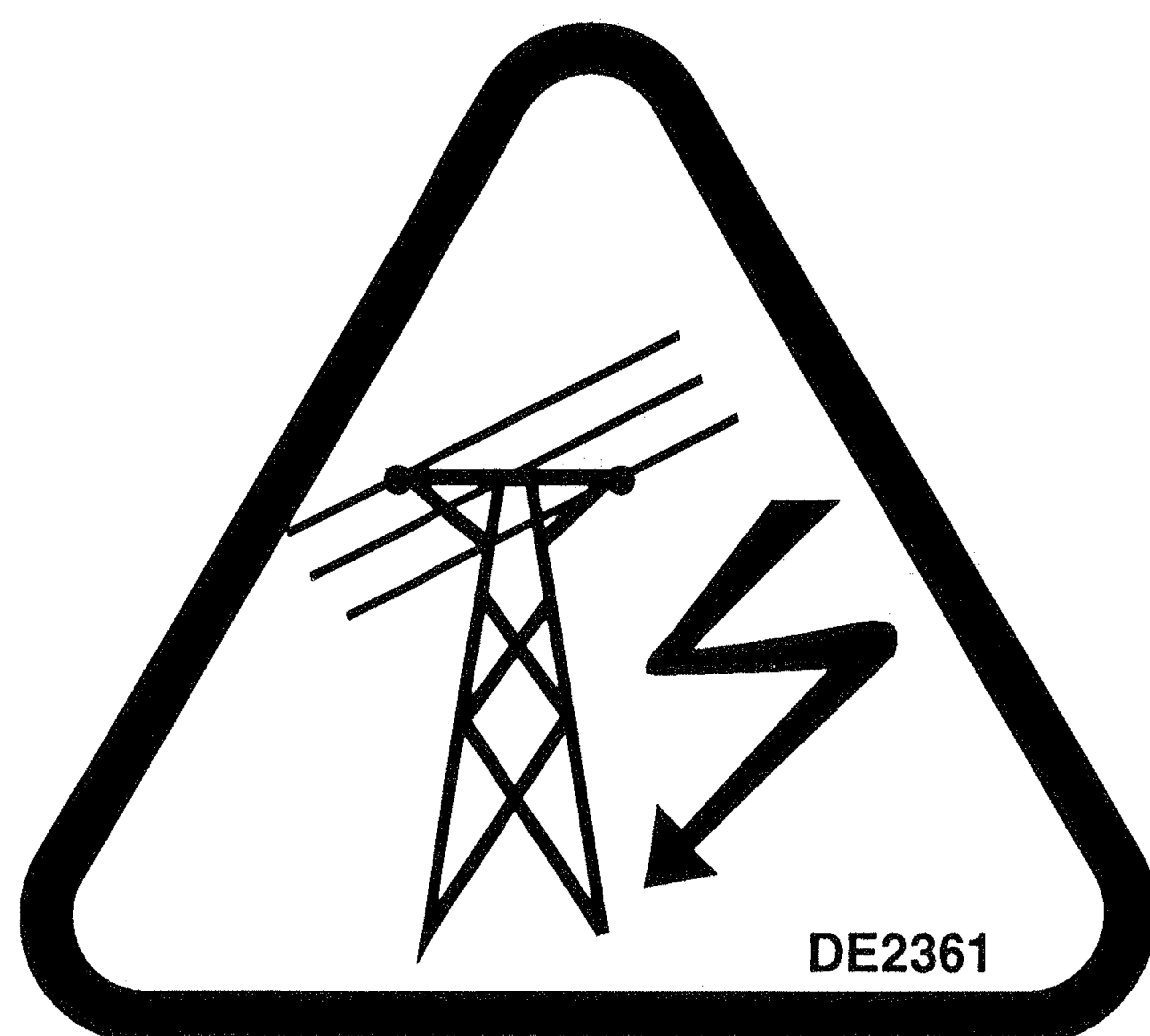

DE2361

DE 2361

Do not operate in proximity of electric high-tension lines

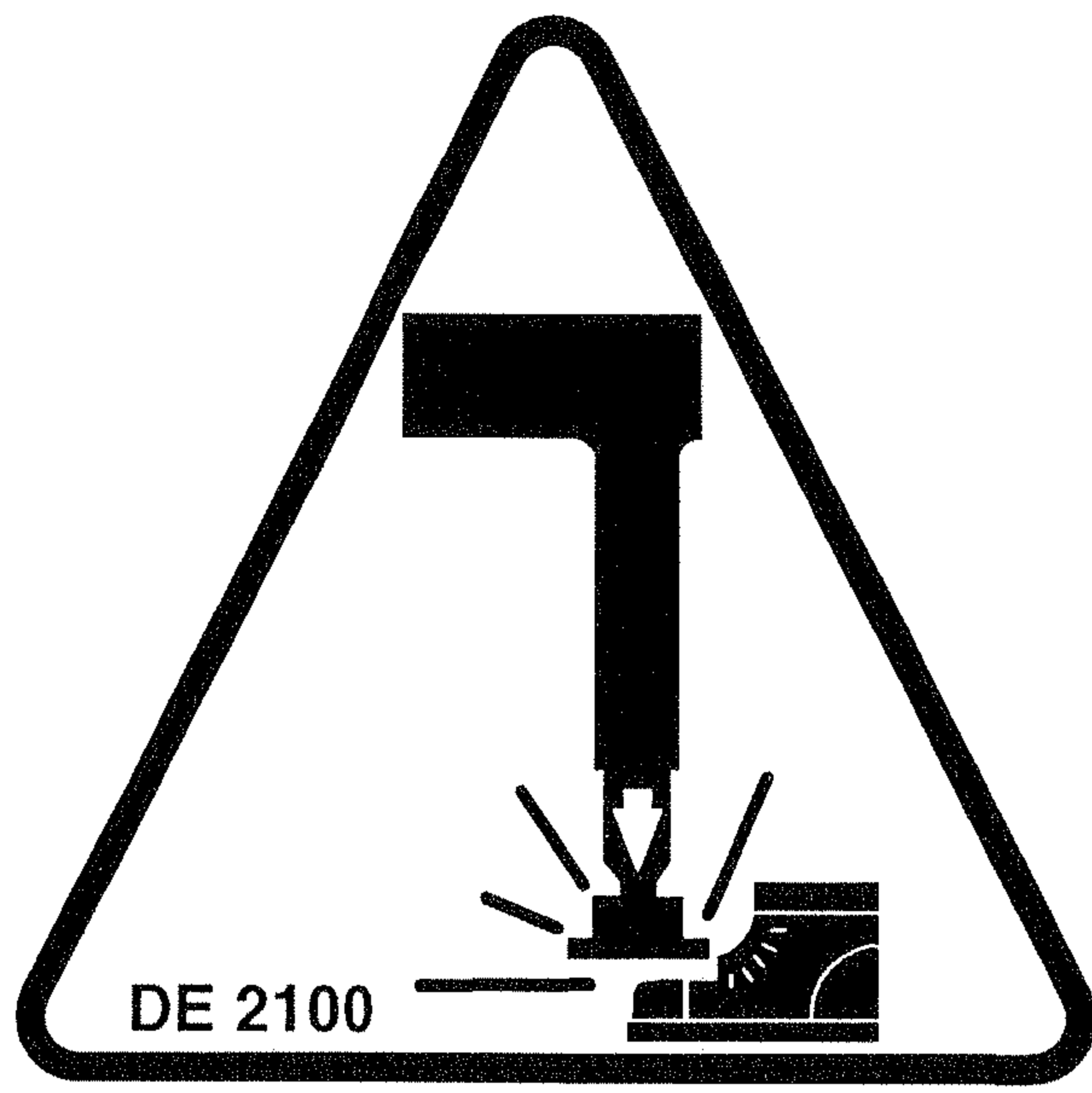

DE 2100
Danger plate for crushing of lower limbs



DE 1681
Greasing points with brush



DE 1682
Greasing points at pressure

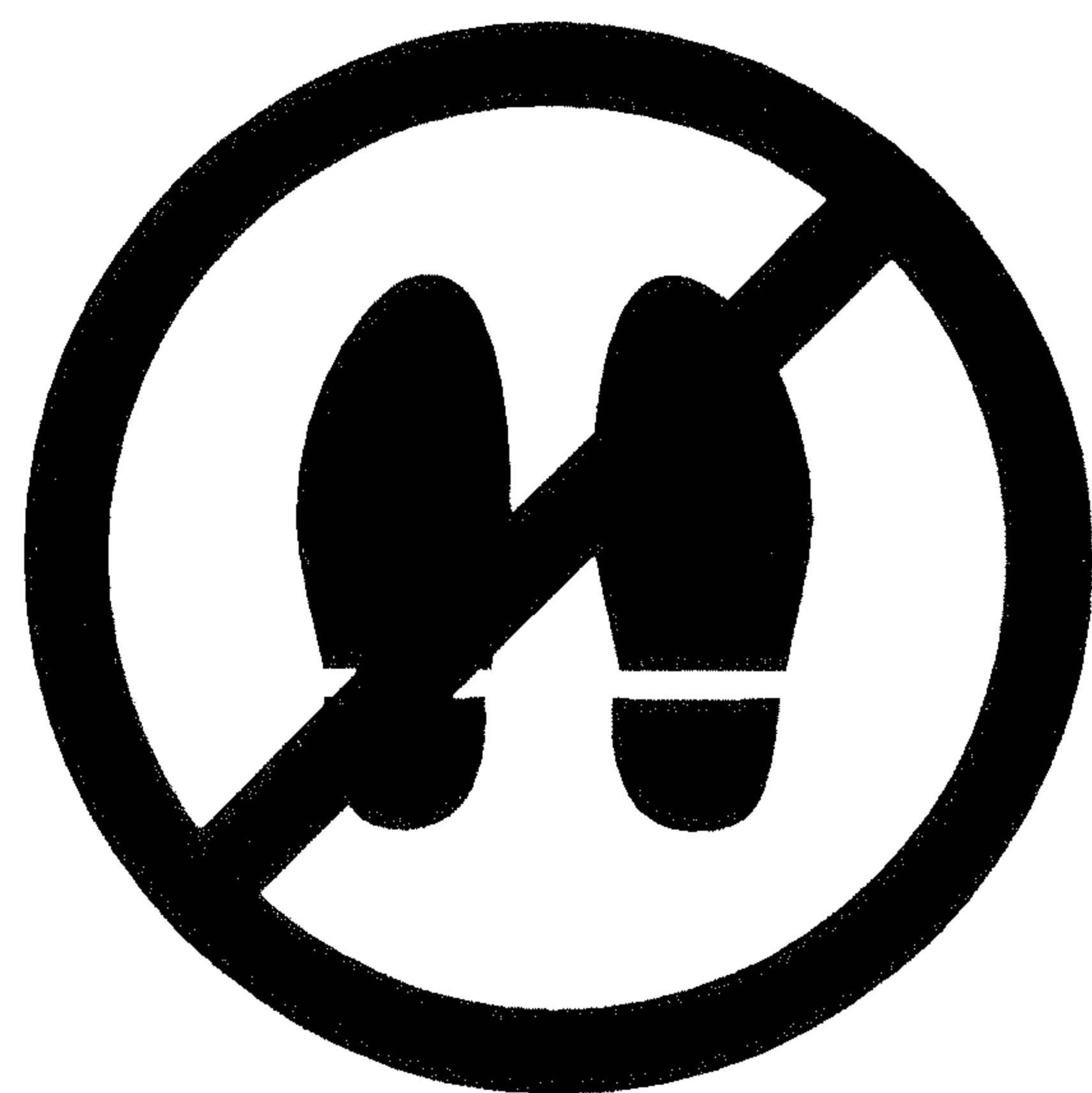

DE 1679
Do not walk on...



DE 1680
Do not use water to extinguish fire

	TIRANTI:	NON SALDARE!
	FIXING ROD:	DO NOT WELD!
	TIRANTS:	NE PAS SOUDER!
	ZUGSCHRAUBEN:	NICHT SCHWEISSEN

DE 1574

Do not weld the fixing rods

CAPACITY PLATES

For cranes and manual extensions.

The represented plates refer to the nominal design capacities.

! WARNING !

If the capacities are downgraded or partially reduced (e.g. sector in front of vehicle cab) capacity plates must be applied in line with the final test figures.

