

# **Chapter 1**

## **Description of the Crane**

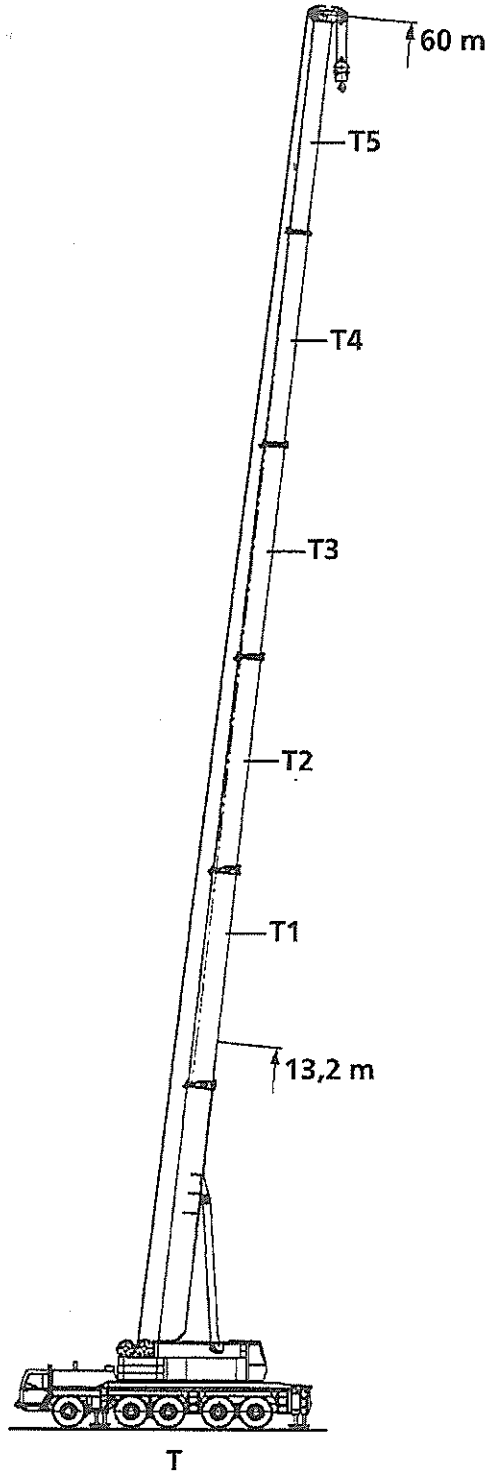

**Abbreviation of boom systems**

T = Telescopic boom

**Boom combination:**

T - Boom combination

T = 13.2 m - 60.0 m

T1 = Telescope 1

T2 = Telescope 2

T3 = Telescope 3

T4 = Telescope 4

T5 = Telescope 5

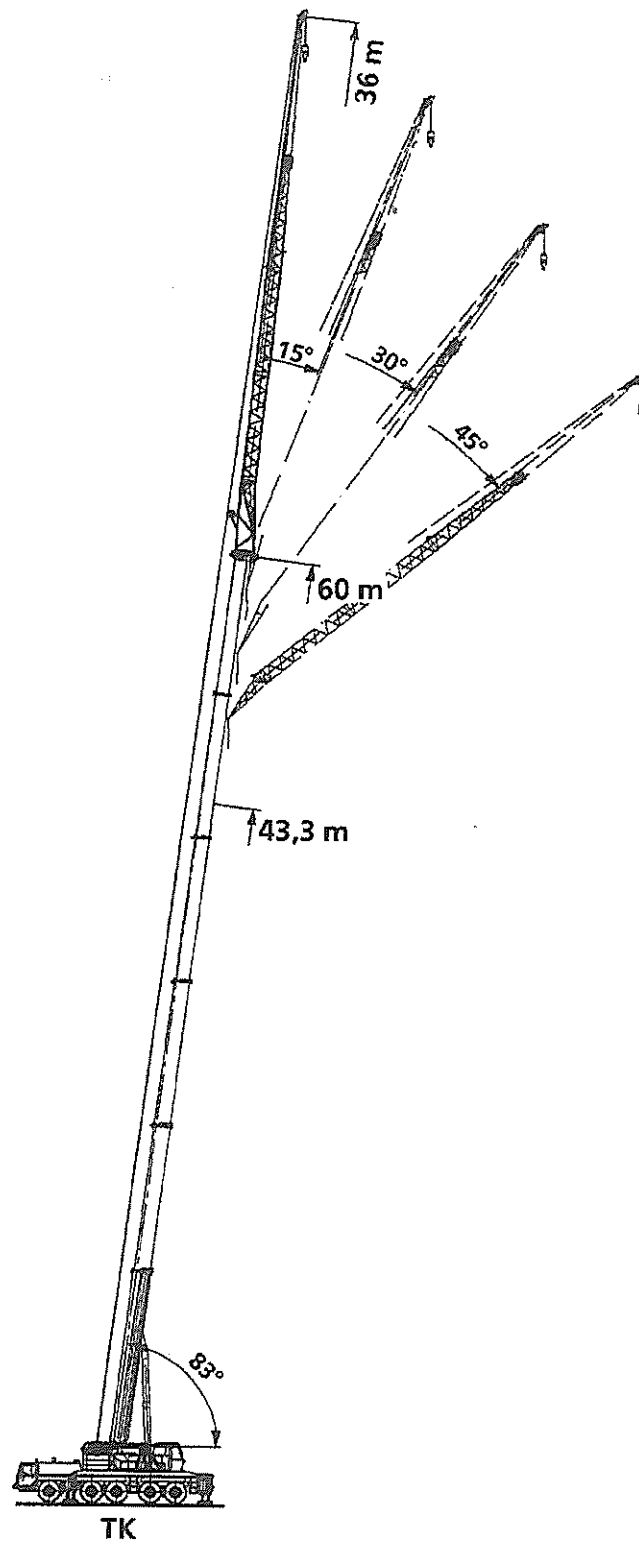

**Abbreviation of boom systems**

- TK 0° = Telescopic boom with folding jib adjusted to a fixed angle (0°)  
 TK 15° = Telescopic boom with folding jib adjusted to a fixed angle (15°)  
 TK 30° = Telescopic boom with folding jib adjusted to a fixed angle (30°)  
 TK 45° = Telescopic boom with folding jib adjusted to a fixed angle (45°)

**Boom combination:**

TK 0° - Boom combination	T = 43.3 m - 60.0 m,	K = 12.2 - 22 m
	T = 43.3 m - 56.3 m,	K = 12.2 m - 36.0 m
TK 15° - Boom combination	T = 43.3 m - 60.0 m,	K = 12.2 - 22 m
	T = 43.3 m - 56.3 m,	K = 12.2 m - 36.0 m
TK 30° - Boom combination	T = 43.3 m - 60.0 m,	K = 12.2 - 22 m
	T = 43.3 m - 56.3 m,	K = 12.2 m - 36.0 m
TK 45° - Boom combination	T = 43.3 m - 60.0 m,	K = 12.2 - 22 m
	T = 43.3 m - 56.3 m,	K = 12.2 m - 36.0 m

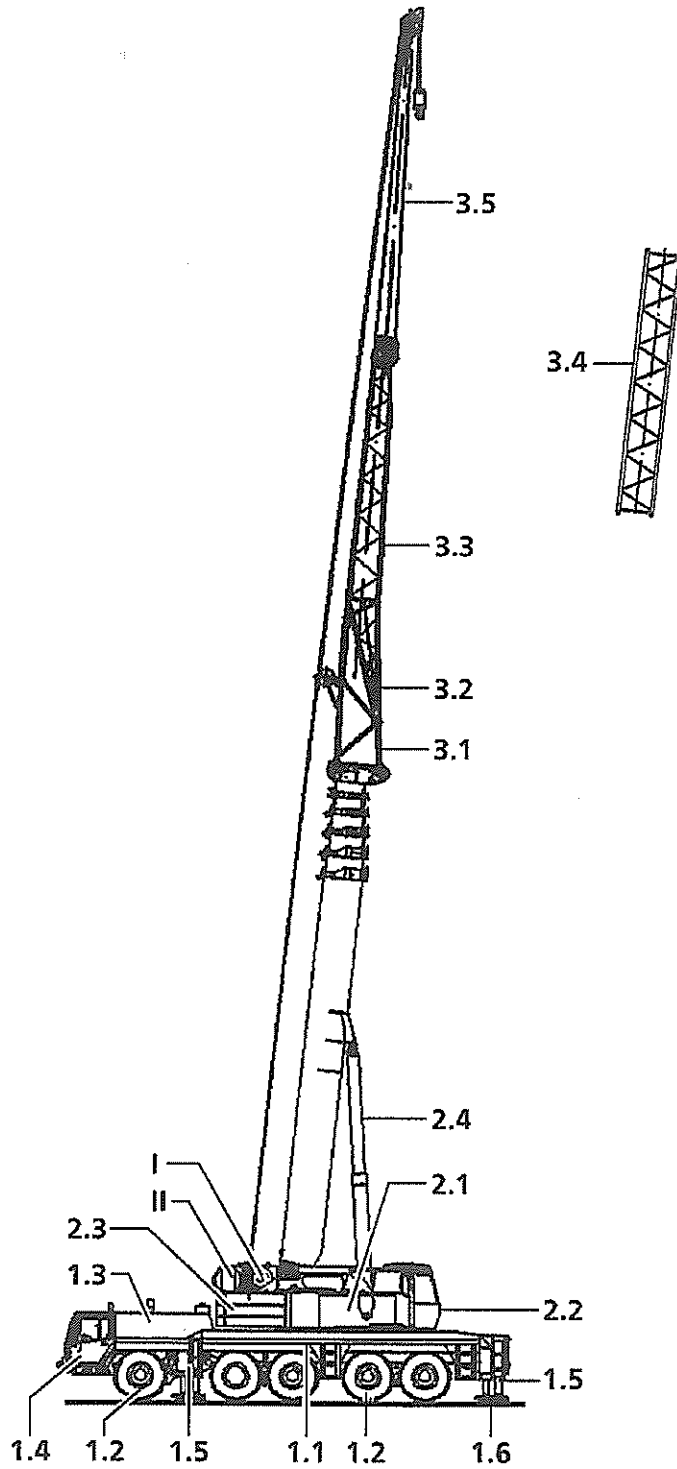

**Component overview****1 Crane chassis**

- 1.1 5- axle chassis
- 1.2 Tires, all axles with single wheels
- 1.3 Travel motor
- 1.4 Driver's cab
- 1.5 Sliding arms with outrigger cylinders
- 1.6 Support pads

**2 Slewing platform**

- I Winch 1 Hoist gear
- II Winch 2 Hoist gear  
or  
Replacement ballast

- 2.1 Crane engine
- 2.2 Crane operator's cab
- 2.3 Counterweight
- 2.4 Telescopic boom ram - luffing cylinder

**3 Folding jib**

- 3.1 Adapter
- 3.2 Pivot section
- 3.2 Extension 7.75 m
- 3.3 Intermediate section 7.00 m
- 3.4 Head section 9.30 m

**The crane carrier**

Frame	Liebherr designed and manufactured box type, torsion resistant construction made of high tensile structural steel.
Outriggers	4 sliding arms with hydraulic extension, with hydraulic outrigger cylinders and support pads. The front support box is installed between axles 1 and 2, the rear support box is located on the rear of the chassis.
Engine	8-cylinder Diesel engine, made by Liebherr, Type D 9408 TI, water cooled, Output per ECE 24.03: 400 kW (544 PS) at 2100 RPM, max. torque: 2250Nm at 1500 RPM Fuel tank capacity: 350 l (92 gal.)
Transmission	Allison Type CLBT 755 automatic transmission with torque converter and hydro - dynamic brake system, 5 forward speeds, 1 reverse speed. Transfer gearbox with differential, off road gear and additional drive for front axle .
Axles	Heavy crane vehicle axles: All 5 axles suspended, axles 1 to 5 steerable. Axles 1,4 and 5 are planetary axles, axle 4 with intermediate axle differential, all driven axles with transverse differential.
Gear shafts	All gear shafts with t 70° cross gears.
Suspension	All axles are provided with hydro - pneumatic suspension with automatic leveling. Axle equalization between axles 1 + 2 and 4 + 5, axle suspension can be locked hydraulically.
Tires	10 wheels, all axles provided with single tires. Tire size 14.00 R 25 resp. 16.00 R 25
Steering	ZF half block hydro steering, with dual circuit system with hydraulic servo system and additional auxiliary steering pump, driven by the axle .
Brakes	Service brake: All wheel servo assisted air brakes, dual circuit. Manual brake: Spring loaded, acting on wheels of axles 2 to 5.
Driver's cab	Large size, all - steel cab with resilient mountings, safety glass windows, full range of control instruments.
Electrical system:	24 V DC, 2 batteries



**The crane superstructure**

Frame:	Liebherr - made torsion resistant, welded construction of high tensile structural steel. Linked to crane carrier by a triple roller slewing ring.
Crane engine	4 cylinder Diesel engine, made by Liebherr, Type D 924 TI - E, watercooled, Output according EPA/CARB and IMO 1 equivalent ISO 8178 C 1: 149 kW (200 PS) at 1800 RPM, max. torque: 891 Nm at 1200 RPM Fuel tank capacity: 300 l (79 gal.)
Crane drive	Diesel hydraulic with two axial piston double pumps with servo control and output regulation.
Crane control	Two 4-way manual, self centering manual control levers.
Hoist gear	Axial piston displacement motor, hoist drum with integrated planetary gear and spring loaded retaining brake.
Luffing gear	1 differential cylinder with safety check valve
Slewing gear	Axial piston fixed displacement motor, planetary gear, slewing gear pinion and spring loaded slewing brake.
Crane cab	Torsion resistant, galvanized, all - steel construction with comfort interior, ergonomically located control and monitoring instruments, cab tiltable to the rear.
Safety devices	"LICCON" overload system, hoist limit, safety valves to protect hydraulic system against pipe and hose ruptures.
Telescopic boom	1 pivot section and 5 telescopic sections, all telescopic section can be extended individually. Boom length: 13.2 m - 60 m (43 ft. to 196 ft.)
Electrical system	24 Volt DC, 2 batteries

**Additional equipment**

Folding jib	12.2 m to 36 m long dual folding jib
2. hoist gear	For two hook operation

Measurements

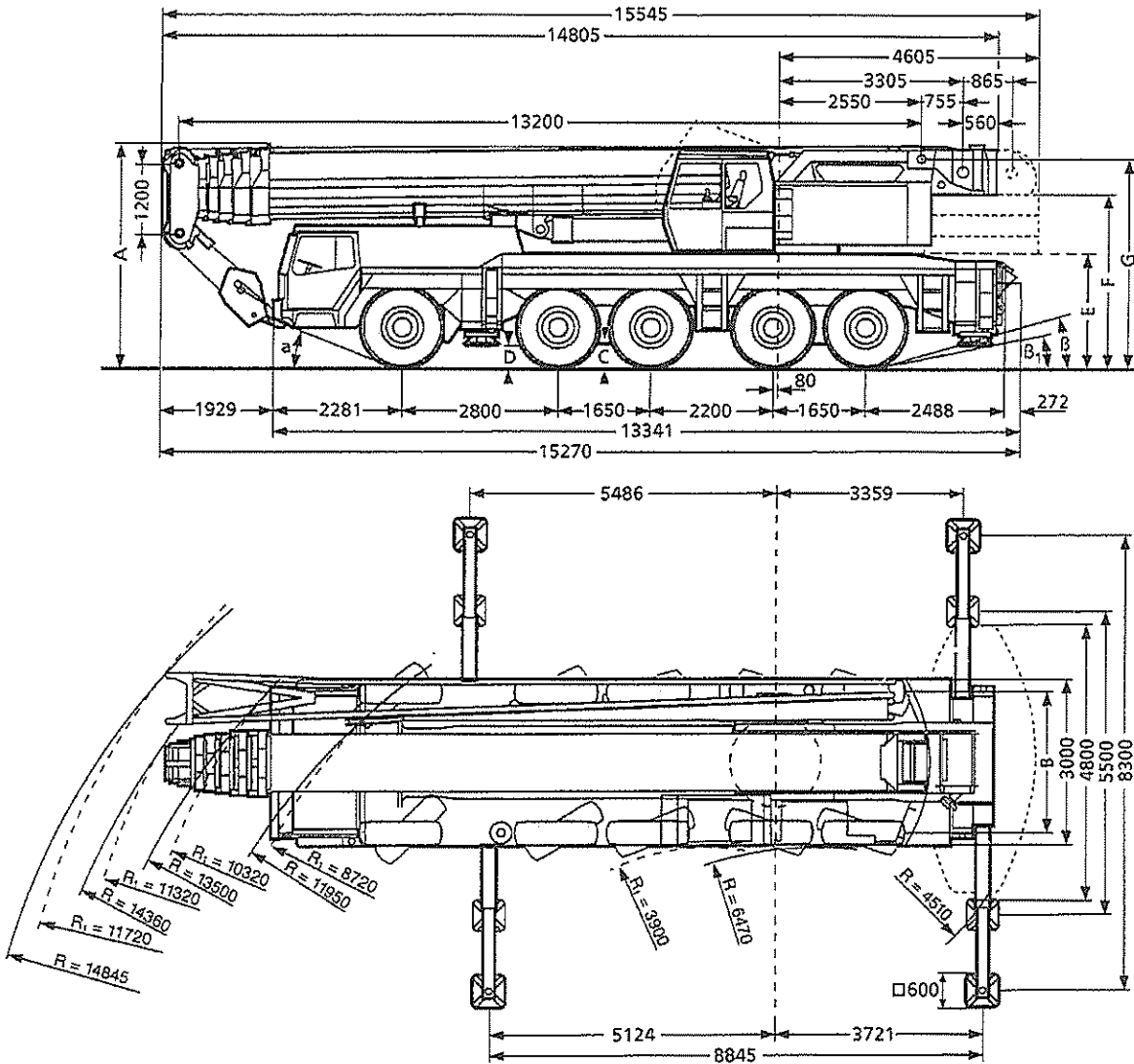

Measurements <sup>1)</sup>

Weights <sup>2)</sup>

- Axle loads (t)
- Lifting tackle

Working speeds <sup>3)</sup>

- Travel speeds
- Crane speeds

Lifting heights <sup>4)</sup>

- Telescopic boom
- Folding jib

Measurement (mm)

Tires	A	A*	B	C	D	E	F	G	a	β	β1
14.00 R 25	3950	3800	2612	420	325	3020	2070	3705	21°	14°	9°
16.00 R 25	4000	3850	2560	470	375	3070	2120	3755	23°	16°	11°

\* lowered by 150mm

Tires

Tire size	Weight of each wheel [approx. in kg]	Tire pressure when driving on public roads [bar]
14.00 - 25	260	10
16.00 - 25 *	336	9 <del>130.5?</del>

1158 CRANE HAS.  
20.5 x 25 105 PSI MAX.

\* = optional

Noise emission values for location :

Noise level at nominal engine RPM	Noise emission values $L_{pAeq}$ [db(A)]	
	left ear	right ear
Driver's cab, driver's side	76	77
Driver's cab, passenger side	75	77
Crane operator's cab	73	73

<sup>1),2),3),4)</sup> Refer to the following pages for data

**Weights****Axle loads (t). Crane in travel position**

- without folding jib
- with 3 sheave hookblock hooked to the front bumper.

Axle	1	2	3	4	5	Total weight
t	12	12	12	12	12	60

**Load tackle**

Load (t)	Pulleys	Reevings	Weight (kg)
160	9	18	2400
137	7	14	1470
100	5	10	1250
68	3	6	430 / 900
30	1	3	760
10	-	1	390

**Max. supporting load per support:**

Max. supporting load [t]	Front	Rear
per support	70	98

## Speeds

## Travel speeds in km/h at engine speed of 2100 RPM

Gear	1	2	3	4	5	R	1	2	3	4	5	R
On road	23	22	34	50	70	12	15	23	36	53	76	13
Off road	8	13	20	29	40	7	8	13	21	31	44	7,5
Uphill driving ability, off road	50%						45%					
	14.00 R 25						16.00 R 25					

## Crane speeds at engine speed of 1800 RPM

Drive	stepless	Cable Ø / cable length
Main hoist gear	0 - 140 m/min for single reeving	23 mm / 295 m
Auxiliary hoist gear	0 - 140 m/min for single reeving	23 mm / 295 m
Slewing gear	0 - 1.5 RPM	
Luffing gear	approx. 50 s to 83° boom position	
Telescoping	approx. 400 s for boom length 13.2 m - 60 m	



Lifting heights

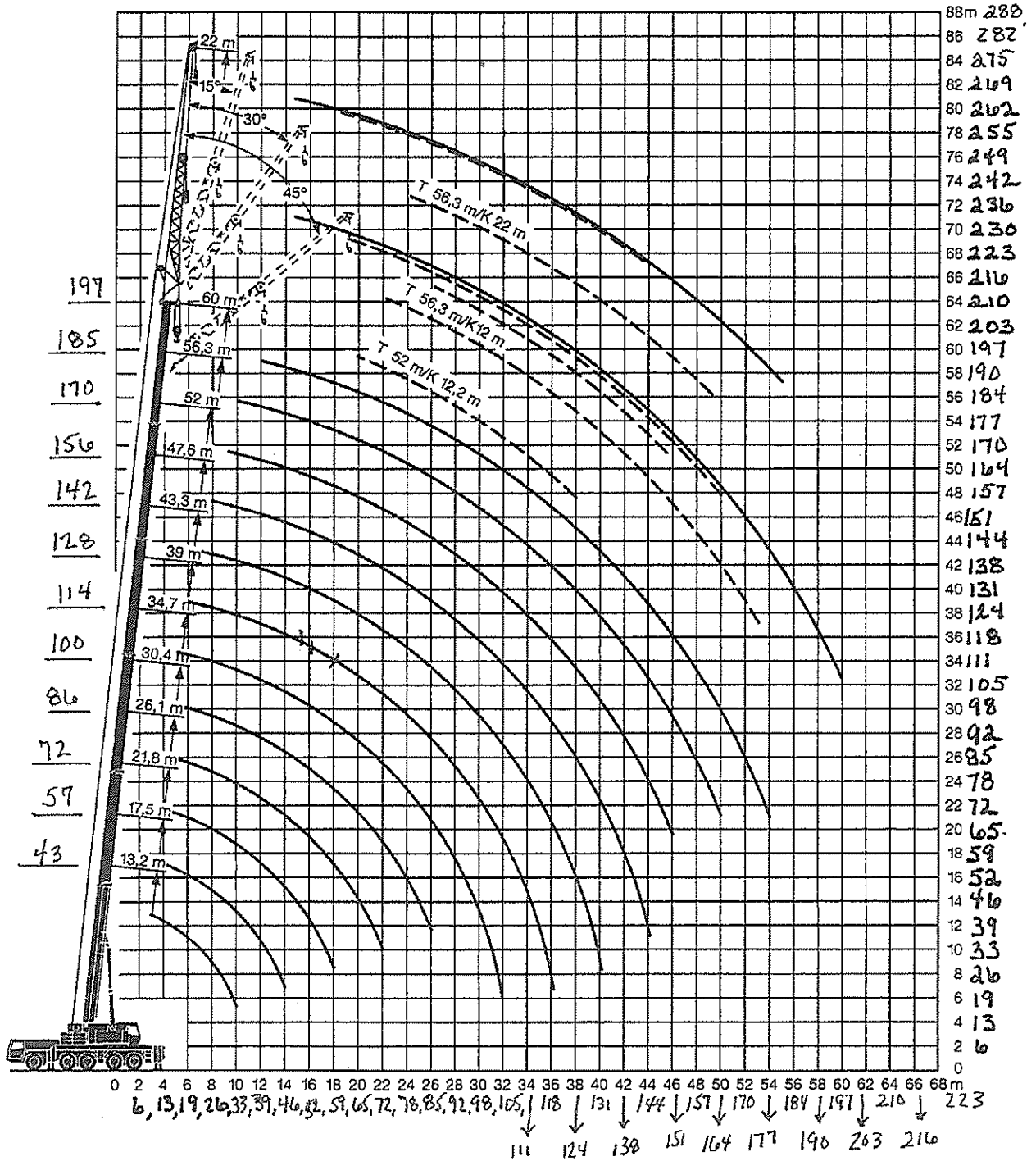

Lifting heights

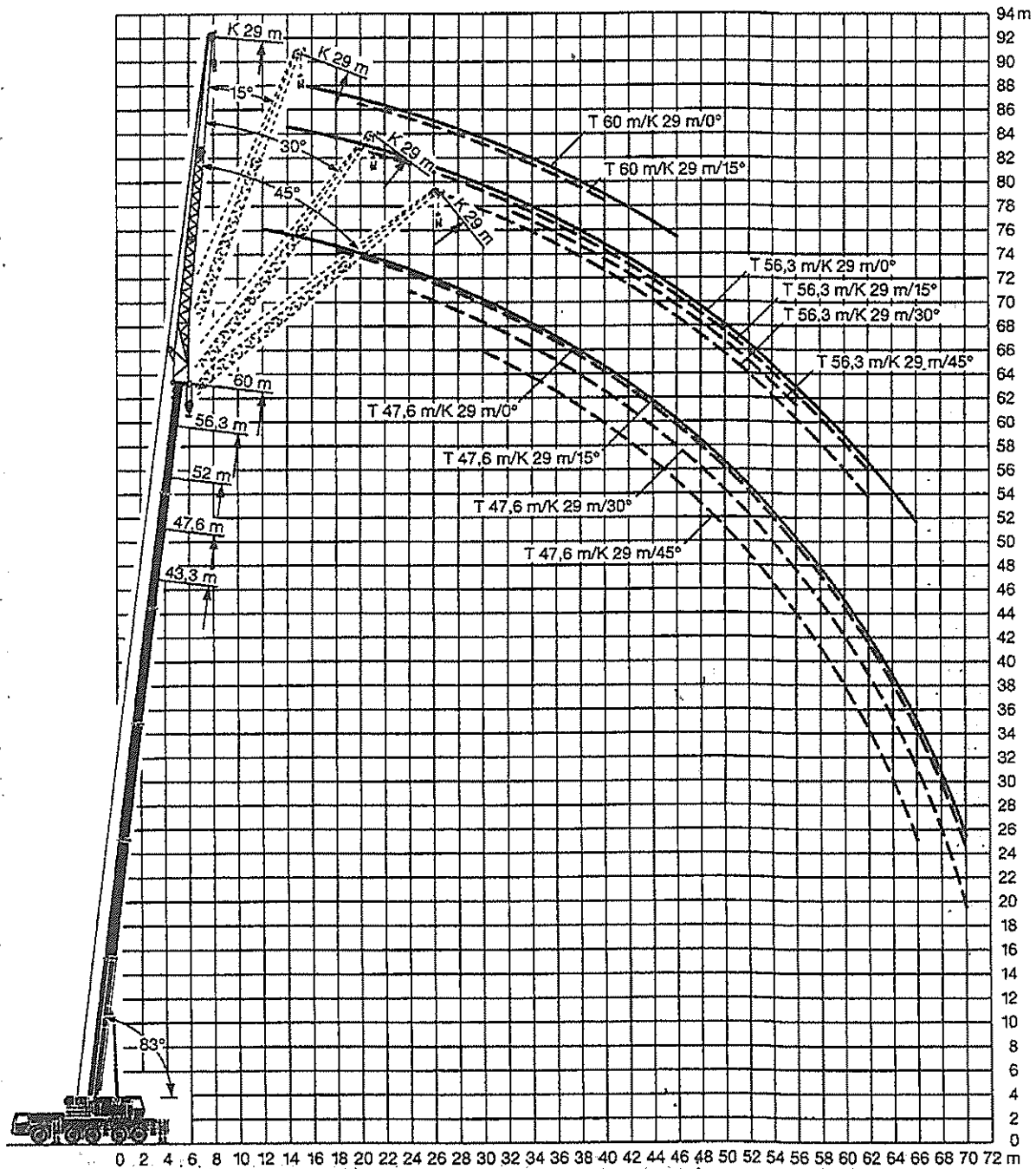



Lifting heights

