

Tech
Spec

IC-200-E

Preliminary Information

- * Capacity on outriggers...
30,000 lbs.
- * Pick and carry capacity...
up to 17,000 lbs.
- * Height...7' 11-1/2"
- * Width...8'
- * Sheave height...up to 60'
- * Horizontal reach...up to 51'
- * Tight turning radius
- * 4-Wheel steer standard
- * 4-Wheel drive optional
- * Powershift transmission
- * Fully hydraulic controls for
smooth precise operation
- * Independent outrigger
controls

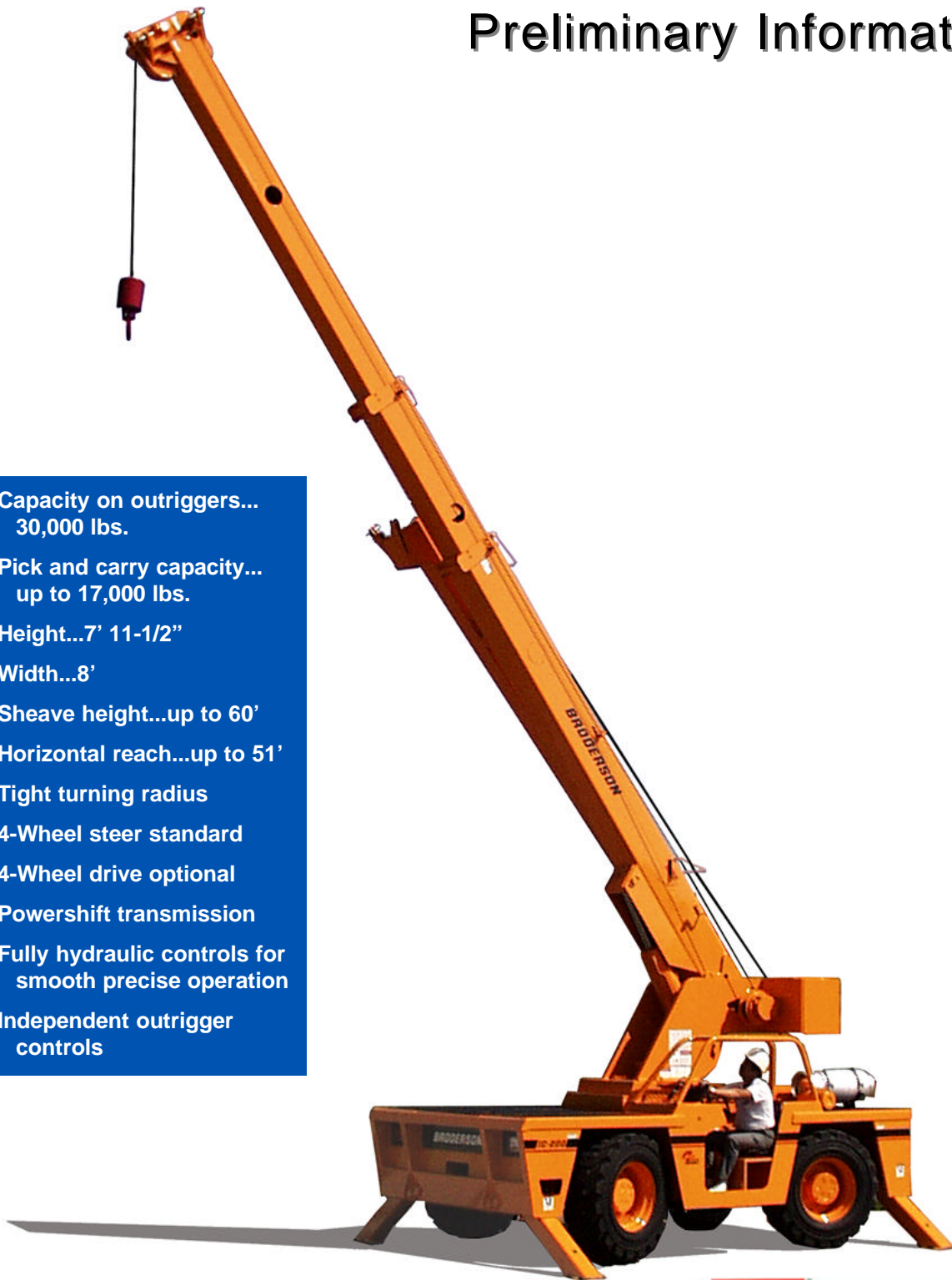

BMC BRODERSON
Manufacturing Corp.

P.O. Box 14770, Lenexa, KS 66285-4770
14741 West 106th St. • Lenexa, KS 66215-2015
(913) 888-0606 • FAX (913) 888-8431
Website: bmcranes.com

IC-200-1E Preliminary Information

CAPACITIES APPLY TO OPERATION ON FIRM LEVEL SURFACE							
LOAD RADIUS FEET	MAIN BOOM OR EXTENSION CAPACITIES IN POUNDS						
	360° ROTATION		OVER FRONT				
	ON RUBBER	ON OUTRIGGERS	ON RUBBER	ON OUTRIGGERS			
6	16500	30000	16500	30000			
8	13500	24000	13500	24000			
10	11000	20000	11300	20000			
12	8200	16400	8700	16400			
14	6400	12700	7500	12700			
16	5200	11200	6300	11200			
18	4300	9900	5200	9900			
20	3600	8900	4400	8900			
22	3100	7950	3800	8100			
24	2750	6950	3300	7400			
26	2400	6150	3000	6700			
28	2150	5500	2600	6200			
30	2000	4300	2500	4300			
32	1800	3950	2250	3950			
36	1400	3450	1800	3450			
40	1000	3100	1400	3200			
43	700	2900	1200	3100			
15' BOOM EXT. ANGLE	15-FOOT BOOM EXTENSION - STRAIGHT OR OFFSET						
	MAIN BOOM ANGLE						
	0°	15°	30°	40°	50°	60°	70°
0°	---	3100	3450	3900	4650	6000	7500
15°	---	3000	3100	3300	3650	4250	5200
30°	---	3000	3050	3200	3450	3900	3900

CAUTION BOOM EXTENSION LOADS MUST NOT EXCEED MAIN BOOM CAPACITY.
BOOM EXTENSION MAY ONLY CARRY LOADS WITH OUTRIGGERS DOWN.

BOOM EXTENSION DEDUCT: 400 POUNDS WHEN STOWED ON BASE BOOM.
800 POUNDS IN WORK POSITION WITH LOAD ON MAIN BOOM.

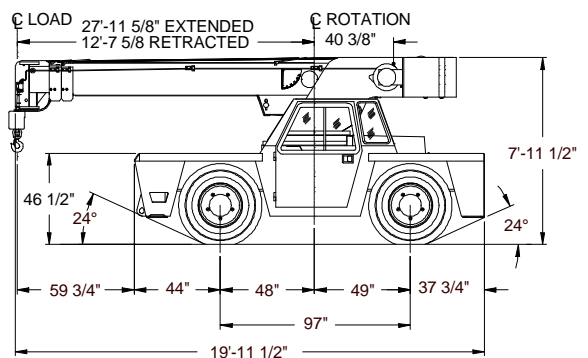
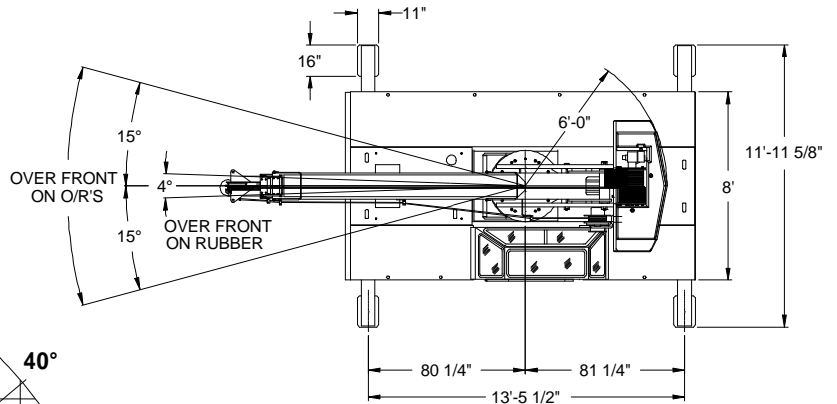
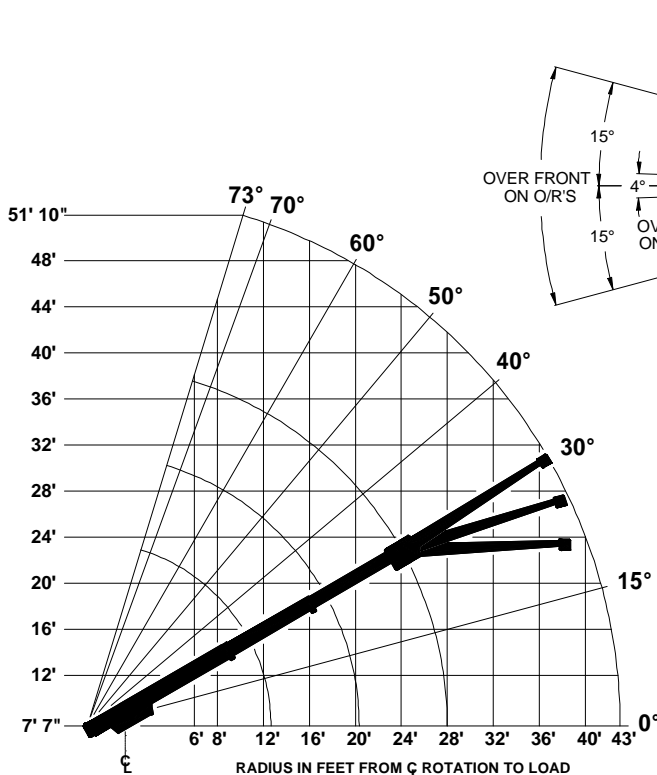
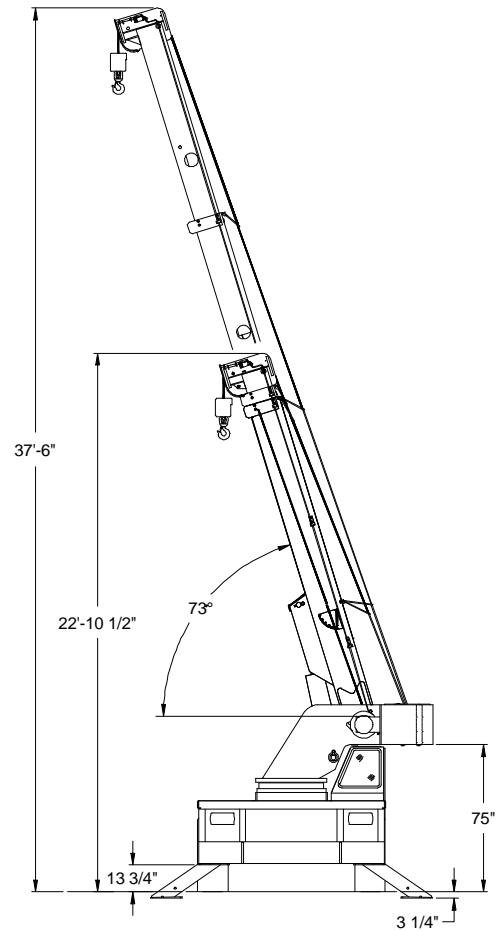
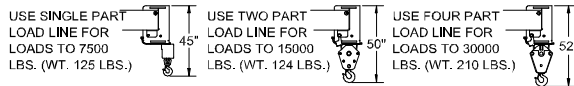

IC-200-2E Preliminary Information

CAPACITIES APPLY TO OPERATION ON FIRM LEVEL SURFACE

LOAD RADIUS FEET	MAIN BOOM OR EXTENSION CAPACITIES IN POUNDS							
	360° ROTATION		OVER FRONT					
	ON RUBBER	ON OUTRIGGERS	ON RUBBER	ON OUTRIGGERS				
6	16200	30000	17000	30000				
8	13200	24000	13800	24000				
10	11000	19800	11500	19800				
12	8100	16100	9600	16100				
14	6250	13500	7900	13500				
16	5000	11200	6300	11200				
18	4100	10000	5100	10000				
20	3400	8800	4300	8800				
22	2850	7700	3600	7800				
24	2400	6600	3000	6900				
26	2100	5750	2600	6200				
28	1850	5150	2300	5700				
30	1650	4650	2100	5300				
32	1450	4200	1850	4900				
36	1150	3400	1500	4200				
40	900	3050	1200	3600				
44	650	2600	950	3100				
48	450	2200	750	2700				
51	250	1900	600	2400				
15' BOOM EXT.	15-FOOT BOOM EXTENSION - STRAIGHT OR OFFSET							
	EXTENSION ANGLE	MAIN BOOM ANGLE						
		0°	15°	30°	40°	50°	60°	70°
	0°	---	3100	3450	3900	4650	6000	7500
15°	---	3000	3100	3300	3650	4250	5200	
30°	---	---	3000	3050	3200	3450	3900	

CAUTION BOOM EXTENSION LOADS MUST NOT EXCEED MAIN BOOM CAPACITY.
BOOM EXTENSION MAY ONLY CARRY LOADS WITH OUTRIGGERS DOWN.

BOOM EXTENSION DEDUCT: 400 POUNDS WHEN STOWED ON BASE BOOM.
800 POUNDS IN WORK POSITION WITH LOAD ON MAIN BOOM.

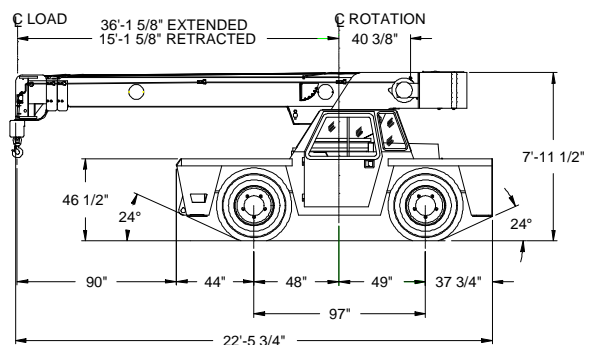
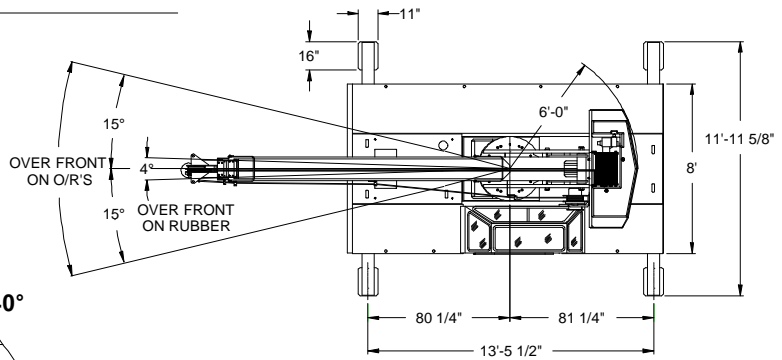
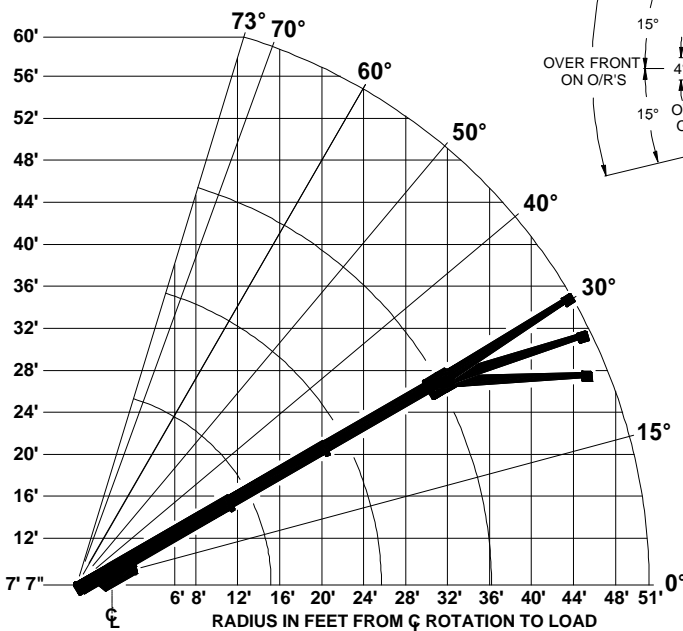
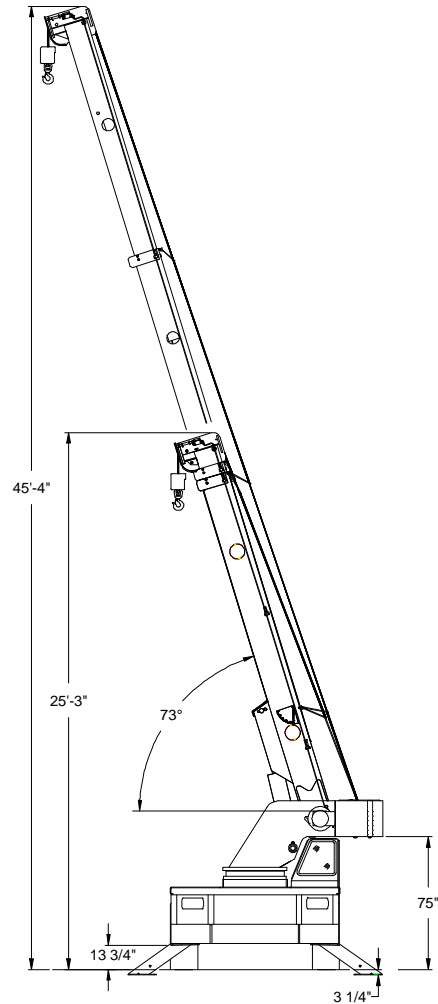
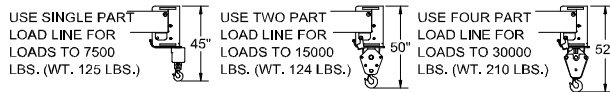

Preliminary Information

GENERAL:

Weight:

IC-200-1E 27,200 lbs.

IC-200-2E 27,650 lbs.

Gradeability: 75%

Turning Radius: 13' 9"

Boom Movement:	IC-200-1E	IC-200-2E
Rotation	Continuous	Continuous
Elevation	0° to 73°	0° to 73°
Extension	15' 4"	21' 0"

Boom Speeds:

Rotation	1.8 RPM	1.8 RPM
Elevation	21 sec.	21 sec.
Extension	26 sec.	35 sec.

ENGINE:

Standard

Optional

Make	GM	Cummins
Model	4.3L V-6	4BT3.9
Type	Gasoline	Turbo-Diesel
No. Cyl.	6	4
Displacement	262 CID	239 CID
HP @ Gov. Speed	110 H.P.	110 H.P.

Fuel Tank Capacity 30 Gallons

TRANSMISSION:

Powershift transmission with 4-speeds forward and reverse. Provides powershifts at any engine speed in any gear. All shifting is done with a single lever electrical control mounted on the steering column. Equipped with torque converter and transmission oil cooler. Torque converter has stall ratio of 2.2:1.

Gear Ratio:

First	5.72:1	Second	3.23:1
Third	1.77:1	Fourth	1.000:1

AXLES:

Front Axle:

Planetary drive/steer front axle with 15.78 to 1.0 ratio. Differential equipped with "limited slip" feature. Front axle mounted rigidly to frame.

Gear	Travel Speed	Drawbar Pull*
First	3 MPH	20,400*
Second	6 MPH	11,430*
Third	11 MPH	6,140*
Fourth	19 MPH	3,350*

*Drawbar pull is calculated for GM 4.3L engine

Rear Axle:

Standard (2-Wheel Drive):

Steering axle with 1-1/2 degree oscillation in either direction.

Optional (4-Wheel Drive):

Planetary drive/steer axle with 24.98 to 1.0 ratio. Differential is not "limited slip" in rear axle. 1-1/2 degree oscillation in either direction. Axle ratio compatible with 4-wheel drive transmission output for front axle match. Transmission equipped with electro-hydraulic control for shifting between 2-wheel drive and 4-wheel drive.

STEERING:

Full hydraulic steering unit with two 3-inch cylinders attached to each axle. Allows limited steering when engine is not running. A switch on the control panel is used to select rear-wheel steering or four-wheel steering.

BRAKES:

Service: Split-system, 4-wheel hydraulic-boosted multiple-plate wet disc brakes.

Parking: Hand lever actuated disc-type parking brake on transmission.

TIRES:

385/65D22.5, 16-ply rating, high-traction on/off road tread.

CHASSIS:

CARGO DECK:

78 square feet of deck area. 17,000 lbs. capacity on deck when load is centered over or between axles. Steps located on front corners.

OUTRIGGERS:

Four hydraulic outriggers of box beam construction with direct-connected holding valves. Independent controls for each outrigger. Outrigger pad dimension 11" x 16".

ACCESSORY STORAGE BOX:

Storage box is 14" deep x 10-1/2" long x 36-1/2" wide, located in front carry deck.

ELECTRICAL:

12 Volt System

Lighting Package:

One pair headlights with high and low beams, tail, brake and turn signal lights and back-up lights in rear, front turn signals and emergency flasher switch at operator's station.

Instrument Package:

Fuel, ammeter, oil pressure, water temperature, transmission oil temperature gauges. All gauges are lighted. Hourmeter records hours only during actual engine operation. Also included are warning lights for low transmission pressure, turn signals, high beams, hazard lights, park brake and four-wheel drive.

Back-Up Alarm:

Provides pulsating sound when transmission is in reverse.

HYDRAULIC SYSTEM:

Tandem pump, direct-driven by engine crankshaft, rated at 29 and 34 GPM at rated RPM. Hydraulic oil tank capacity of 54 gallons.

BOOM ASSEMBLY:

Three-section boom assembly equipped with bearing pads, double acting hydraulic cylinders with direct-connected holding valves and boom angle indicator on each side of boom.

Boom Rotation:

Heavy-duty ball bearing rotation gear with external teeth. Rotation is powered by hydraulic motor and worm gear drive.

Boom Hoist:

Turret mounted planetary gear hoist hydraulically powered with a bare drum line pull of 10,000 lbs. at a line speed of 100 FPM. Includes downhaul weight, swivel hook and sheave block for 4-part line and 240 ft. of 1/2" hoist rope.

Anti-Two-Block Device:

Prevents damage to hoist rope and/or crane components from pulling load hook against tip.

Sheave Block, Four Part

Double sheave block for 4-part line requirements.

Preliminary Information

Listed below are brief descriptions of each option available for the IC-200-E Industrial Crane. Consult the IC-200-E Engineering Spec for additional information on each option.

MODEL:

IC-200-1E Industrial Crane with
12' 8"-28' 0" Boom

IC-200-2E Industrial Crane with
15' 2"-36' 2" Boom

ENGINE OPTIONS:

Diesel Engine

Cummins Turbo-4BT3.9

Spark Arrester Muffler

Installed in addition to std. muffler.

Catalytic Converter

Reduces engine emissions.

Engine Heater

Engine coolant heater installed to circulate warm water through engine, plugs into 120 volt AC.

Ether Injection System

Ether starting aid controlled by switch in operator compartment and injects ether directly into intake manifold.

Engine Shut Down Gauges

Shuts engine off when high water temperature or low engine oil pressure occurs. (Diesel Only)

Axle & Steering Options:

4-Wheel Steer & 2-Wheel Drive

4-Wheel Steer & 4-Wheel Drive

TIRE OPTIONS:

Foam Filling of Tires

Non-Marking Tires

Spare Tire & Wheel

CHASSIS OPTIONS:

Auxiliary Winch

Mounted behind front bumper, hydraulically driven with control in operator's console.

Pintle Hook:

Pintle Hook, Rear

Pintle Hook, Front

Headlight and Taillight Grilles

Welded steel protective grilles for headlights and taillights.

Rearview Mirrors

One mounted on right-hand deck stake and 1 mounted on left-hand deck stake.

Lifting Rings

Lifting rings at each corner of carry deck so sling can be attached for lifting crane.

OPERATOR COMPARTMENT

OPTIONS:

Operator Guard

Tubular steel weldment with heavy expanded steel mesh top section.

Operator Guard Cover

Clear vinyl cover over Operator Guard, for inclement weather operations.

Operator Guard Door

Hinged door covers operator compartment side opening.

All Weather Cab

Rigid-mounted canopy section and removable hinged door. Includes heater, electric windshield wiper, one sliding glass window in the door & one in the right side of canopy. Defroster fan & dome light included.

Cab Heater Only

Heater with two-speed fan for units without All Weather Cab.

Windshield Washer

Includes reservoir, pump and nozzle.

Floor Mat

Vinyl mat with foam backing.

Operator Suspension Seat

Provides additional operator comfort.

Noise Reduction Kit

Includes floor mat, control valve cover and side panels of foam backed vinyl for noise reduction.

Air Conditioning

Air Conditioner with R 134 coolant.

ELECTRICAL OPTIONS:

Outrigger Alarm System

Two-tone alarm is activated when "outrigger down" controls are operated.

Strobe Lights

Yellow strobe light mounted on each side of turret weight box.

Amber Rotating Beacons

Amber rotating beacon mounted on each side of turret weight box.

Boom Work Lights

One work light mounted to boom to light boom tip and one work light mounted to turret to light ground under boom tip.

ELECTRICAL OPTIONS: (Cont'd)

Boom Work Lights and Beacons

Boom work lights and amber rotating beacons installed.

Boom Work Lights and Strobes

Boom work lights and strobe lights installed.

BOOM ATTACHMENTS:

Boom Extension, 15 Ft.

Boom stowable.

Boom Extension, 15 Ft., Offsettable (2E Only)

Same as above except the boom extension is offsettable to 3 different positions; 0 degree (inline), 15 degree and 30 degree offset.

Sheave Block - Two-Part

Searcher Hook:

Nose Mount

Link Under Tip

Load Moment Indicator

Warns operator of impending overload with audible and visual signals. Prevents overload by stopping boom functions that cause overloads. Readouts for load, boom angle, boom length and load radius.

Load Indicator

Includes 3-sheave load sensor on top of boom and readout box on top of instrument panel.

Should you, as an end user, require an option or special equipment on your IC-200-E that is not listed on our sales literature, please contact your dealer salesperson or the factory to receive a special quoted price.

IC-200-E

Preliminary Information



IC-20



IC-35



IC-80



IC-200-3D

BMD BRODERSON
Manufacturing Corp.

P.O. Box 14770, Lenexa, KS 66285-4770
14741 West 106th St. • Lenexa, KS 66215-2015
(913) 888-0606 • FAX (913) 888-8431
Website: bmcrcranes.com