

500 Ton All-Terrain Crane

Demag AC 1300

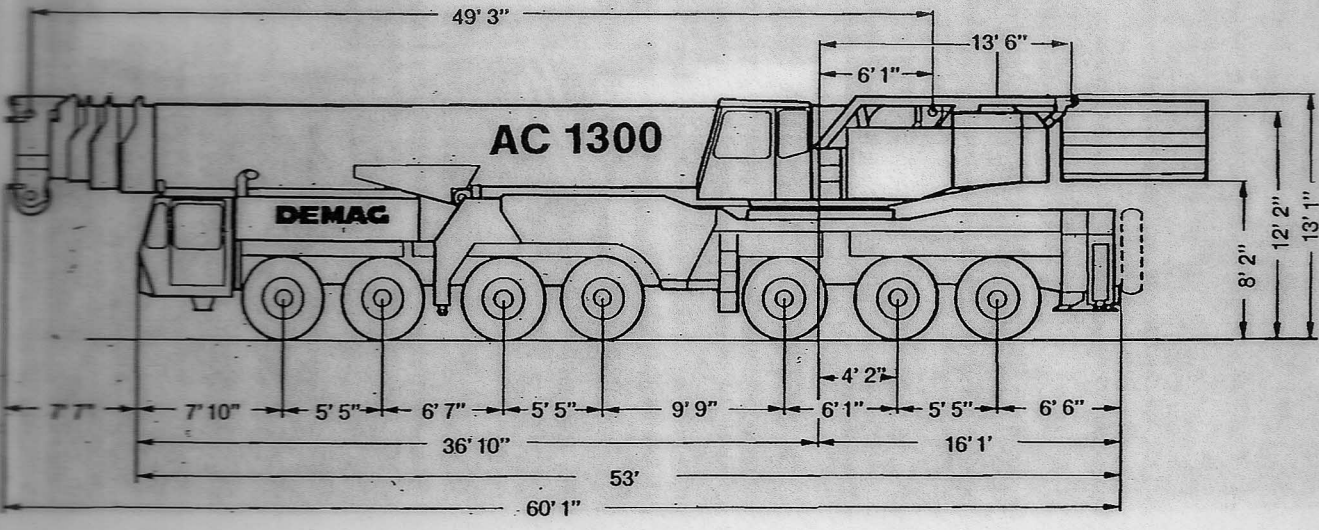

Dimensions



Dimensions

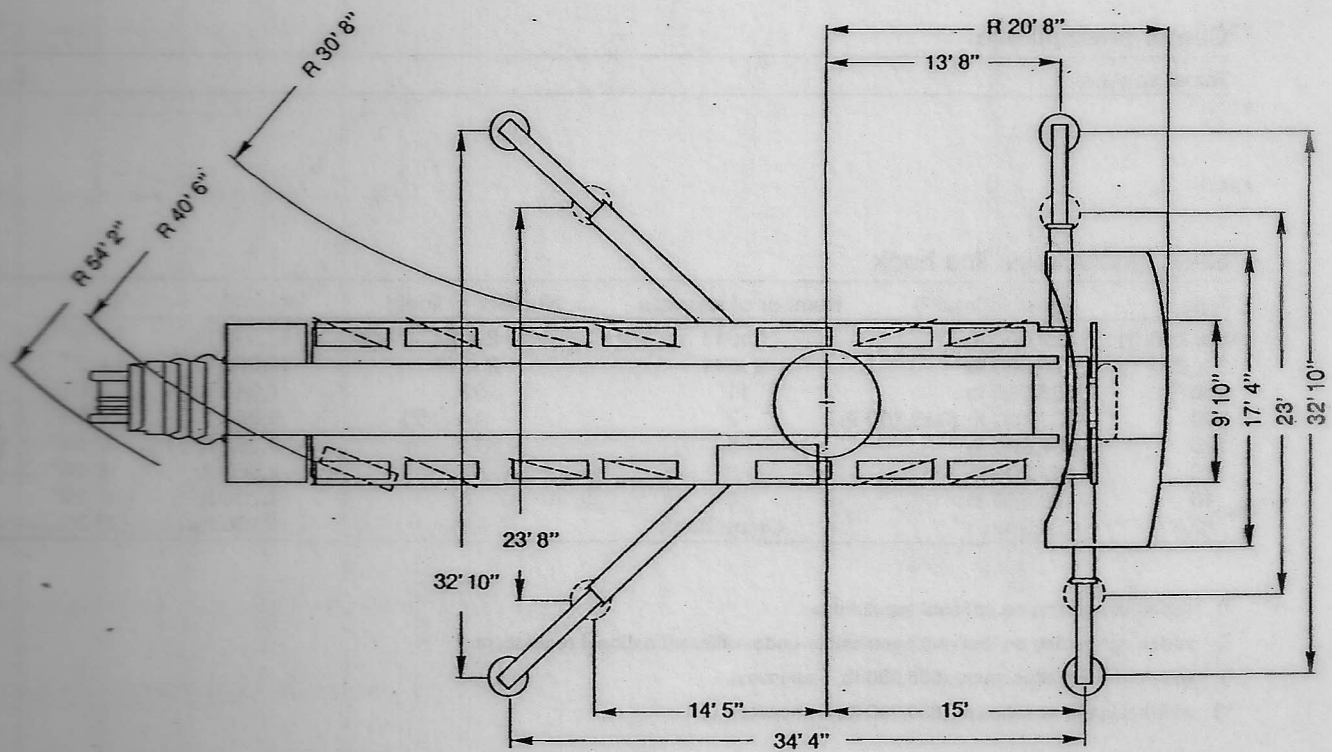

*) Duties with reduced outrigger base upon request

Specifications

Axle loads and weights

Crane with main boom, outriggers and hook block
 Axles
 Total weight

7 x 25,400 lb
 154,800 lb

Working speeds (infinitely variable)

Units	Line speed	Max. permissible line pull ¹⁾	Length of hoist rope
Main hoist	max. 525 ft/min	110 kN	1542 ft
Secondary hoist	max. 525 ft/min	110 kN	1378 ft
Swing			max. 1,0 rpm
Telescoping speed			49 - 113 ft: 110 s 49 - 190 ft: 330 s
Boom elevation			-0,5° - +82°: 95 s

Carrier performance

Travel speeds

0...40 mph

Hook block/Single line hook

Type	Possible load ²⁾	Number of sheaves	Number of lines	Weight	"D"
2 x 250 ^{**)}	880,000 lb	2 x 11	2 x 22	17,600 lb	14' 9"
2 x 250 ^{**)}	770,000 lb	2 x 11	2 x 17	17,600 lb	14' 9"
250 ^{*)}	506,000 lb	11	23	7,040 lb	9' 10"
160	323,400 lb (343,200 lb)	7	14 (15 [*])	5,060 lb	9' 10"
125	257,000 lb	5	11	3,960 lb	9' 10"
80	167,200 lb	3	7	2,860 lb	9' 10"
40	72,600 lb	1	3	1,760 lb	8' 10"
12,5	24,200 lb	Crane hook	1	1,100 lb	6' 7"

¹⁾ varies depending on national regulations

²⁾ varies depending on line pull permissible under different national regulations

^{*)} with heavy-lift attachment (506,000 lb, 5 sheaves)

^{**)} with heavy-lift attachment (880,000 lb, 5 sheaves)

Working ranges main boom

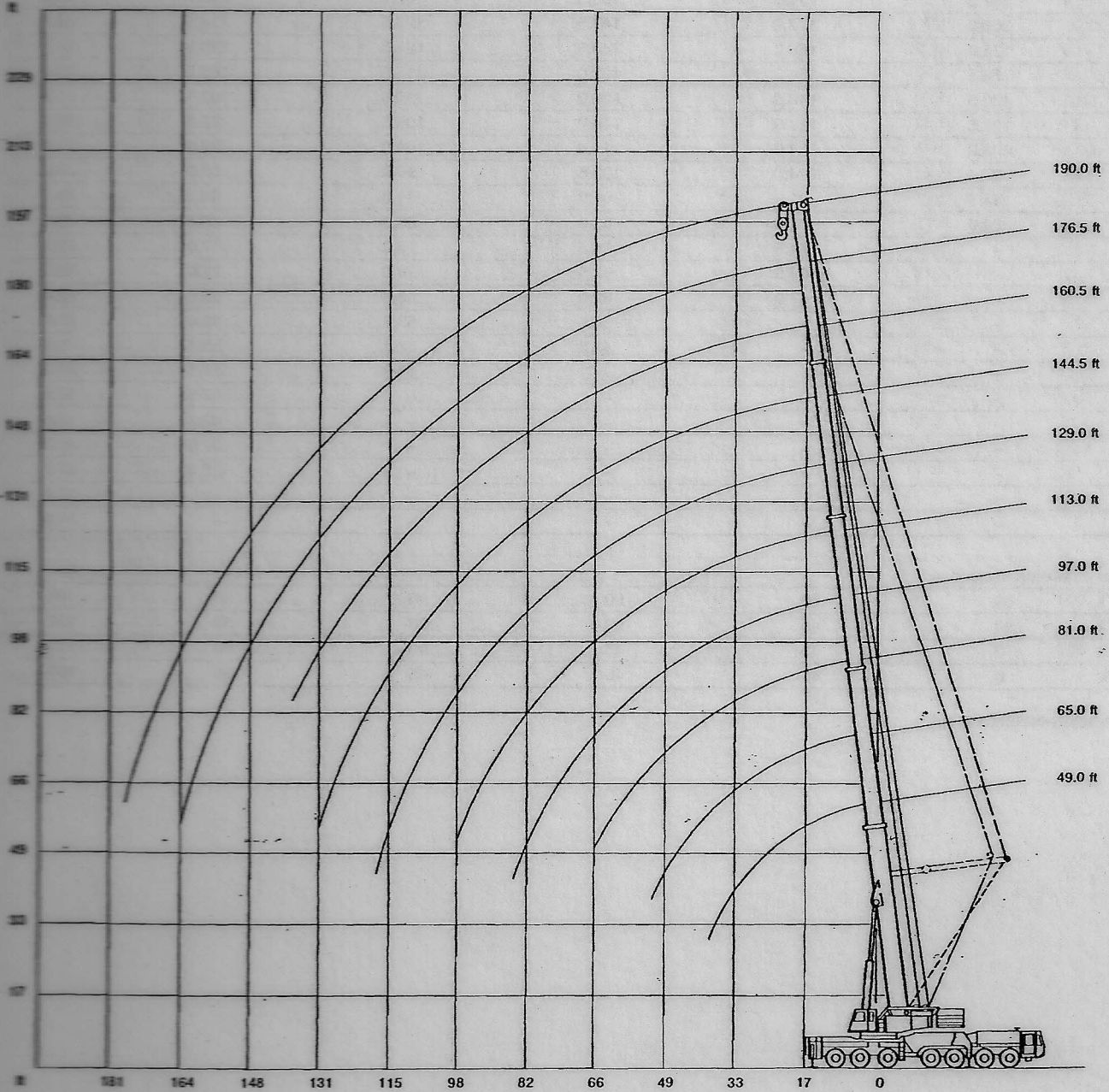

Lifting capacities main boom with Superlift in 1,000 lb

269,000 lb

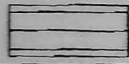

360°

85%

Radius ft	Main boom					
	113.0 ft	129.0 ft	144.5 ft	160.5 ft	176.5 ft	190.0 ft
	1,000 lb					
23	286.0*	231.0*	-	-	-	-
26	282.0*	223.0*	173.0	-	-	-
29	271.0*	215.0	169.0	142.5	-	-
33	257.0	204.0	165.0	138.5	119.0	-
39	232.0	191.5	155.5	132.5	119.0	83.5
46	200.0	177.0	147.5	126.5	114.5	83.5
52	178.0	166.0	140.5	121.5	110.5	81.5
59	156.5	154.0	132.0	115.5	105.5	80.0
65	138.5	143.0	126.0	110.5	101.5	79.0
72	122.5	127.0	118.0	105.5	97.0	78.0
79	108.5	114.0	111.0	100.0	92.0	77.0
85	97.5	104.0	103.5	96.0	88.0	77.0
92	84.5	91.0	91.0	91.0	84.5	76.0
98	69.0	82.0	83.0	85.0	80.5	75.0
105	-	74.5	74.5	76.0	77.0	72.5
111	-	64.5	67.5	70.0	72.0	69.5
118	-	47.0	62.0	63.5	65.5	66.0
124	-	-	55.6	58.7	60.5	61.0
131	-	-	43.2	53.3	55.7	55.9
138	-	-	-	48.8	50.8	51.2
144	-	-	-	-	47.3	47.6
151	-	-	-	-	43.3	43.6
157	-	-	-	-	37.9	40.7
164	-	-	-	-	28.0	37.2
170	-	-	-	-	-	32.6
177	-	-	-	-	-	24.0
Boom extension sequence						
						%
Tale 1	90	90	90	90	90	100
Tale 2	90	45	90	90	90	100
Tale 3	0	45	45	90	90	100
Tale 4	0	45	45	45	90	100

* with heavy-lift attachment

Lifting capacities main boom with Superlift in 1,000 lb

211,500 lb   360°

85%

Radius ft	Main boom					
	113.0 ft	129.0 ft	144.5 ft	160.5 ft	176.5 ft	190.0 ft
23	286.0*	231.0*	-	-	-	-
26	282.0*	223.0*	173.0	-	-	-
29	271.0*	215.0	169.0	142.5	-	-
33	257.0	204.0	165.0	138.5	119.0	-
38	228.0	191.5	155.5	132.5	119.0	83.5
46	193.5	177.0	147.5	126.5	114.5	83.5
52	168.5	166.0	140.5	121.5	110.5	81.5
59	142.0	147.5	132.0	115.5	105.5	80.0
65	121.0	127.5	126.0	110.5	101.5	79.0
72	100.5	107.0	108.5	105.5	97.0	78.0
79	86.5	93.0	94.0	95.0	92.0	77.0
85	76.5	82.0	82.0	85.0	87.0	77.0
92	67.0	72.5	72.5	74.5	77.0	75.5
98	60.0	65.5	65.5	67.5	69.5	69.5
105	-	58.1	58.4	60.0	62.0	63.0
111	-	52.7	52.9	54.7	56.9	57.3
118	-	46.8	47.0	49.0	51.2	51.4
124	-	-	42.8	44.3	46.9	47.4
131	-	-	38.0	39.8	42.0	42.7
138	-	-	-	35.5	38.0	38.6
144	-	-	-	-	35.0	35.4
151	-	-	-	-	31.4	31.9
157	-	-	-	-	28.8	29.1
164	-	-	-	-	26.2	26.4
170	-	-	-	-	-	24.4
177	-	-	-	-	-	22.1

Boom extension sequence	%					
Tale 1	90	90	90	90	90	100
Tale 2	90	45	90	90	90	100
Tale 3	0	45	45	90	90	100
Tale 4	0	45	45	45	90	100

* with heavy-lift attachment

Lifting capacities main boom in 1,000 lb

269,000 lb  360°

85%

Radius ft	Main boom													
	49.0 ft	49.0 ft	65.0 ft	81.0 ft	97.0 ft	97.0 ft	113.0 ft	113.0 ft	129.0 ft	144.5 ft	160.5 ft	176.5 ft	190.0 ft	
10	1,000.0 ²⁾	-	-	-	-	-	-	-	-	-	-	-	-	
10	869.0 ^{**1)}	600.0 ^{**}	-	-	-	-	-	-	-	-	-	-	-	
11	788.0 ^{**1)}	574.0 ^{**}	569.0 ^{**}	-	-	-	-	-	-	-	-	-	-	
13	668.0 ^{**1)}	523.0 ^{**}	521.0 ^{**}	-	-	-	-	-	-	-	-	-	-	
15	587.0 ^{**1)}	484.0 ^{**}	480.0 ^{**}	-	-	-	-	-	-	-	-	-	-	
16	553.0 ^{**1)}	466.0 ^{**}	463.0 [*]	401.0 [*]	300.0	343.0 [*]	-	-	-	-	-	-	-	
19	470.0 ^{*1)}	418.0 [*]	416.0 [*]	368.0 [*]	276.0	329.0 [*]	253.0	255.0	-	-	-	-	-	
23	365.0 [*]	365.0 [*]	363.0 [*]	325.0 [*]	248.0	306.0	229.0	242.0	209.0	-	-	-	-	
26	335.0 [*]	335.0 [*]	333.0 [*]	297.0	232.0	284.0	212.0	230.0	201.0	167.0	-	-	-	
29	308.0	308.0	306.0	282.0	216.0	267.0	200.0	218.0	189.5	159.5	135.0	-	-	
33	276.0	276.0	274.0	254.0	195.0	241.0	181.0	204.0	175.5	149.0	128.5	102.0	-	
39	240.0	240.0	240.0	226.0	170.0	215.0	155.5	184.0	155.5	135.0	120.5	98.0	84.0	
46	-	-	208.0	194.5	145.0	187.0	133.0	162.5	134.0	121.0	109.0	92.5	79.0	
52	-	-	179.5	172.5	129.0	167.0	118.0	146.5	121.0	111.0	99.5	86.0	75.0	
59	-	-	-	150.0	110.0	145.5	105.5	132.0	107.0	101.0	89.0	80.5	70.5	
65	-	-	-	130.5	98.0	129.5	95.5	122.0	97.5	93.0	82.0	75.0	65.0	
72	-	-	-	-	84.0	115.0	85.0	110.5	88.0	84.0	76.0	69.5	61.0	
79	-	-	-	-	72.0	101.5	76.5	101.0	81.0	76.5	70.0	64.0	57.1	
85	-	-	-	-	63.5	84.5	69.5	95.0	74.0	70.5	66.0	60.0	53.9	
92	-	-	-	-	-	-	64.5	84.5	67.0	63.5	61.5	55.9	49.7	
98	-	-	-	-	-	-	57.8	77.5	61.0	58.9	56.5	52.7	46.9	
105	-	-	-	-	-	-	-	-	55.1	54.0	52.2	49.3	43.6	
111	-	-	-	-	-	-	-	-	51.0	49.9	48.8	46.5	41.2	
118	-	-	-	-	-	-	-	-	45.5	45.4	45.4	43.0	38.8	
124	-	-	-	-	-	-	-	-	-	42.8	42.8	40.8	36.4	
131	-	-	-	-	-	-	-	-	-	39.7	39.7	38.6	34.4	
138	-	-	-	-	-	-	-	-	-	-	37.4	36.3	32.1	
144	-	-	-	-	-	-	-	-	-	-	-	34.2	30.9	
151	-	-	-	-	-	-	-	-	-	-	-	32.1	29.0	
157	-	-	-	-	-	-	-	-	-	-	-	30.5	27.6	
164	-	-	-	-	-	-	-	-	-	-	-	-	6.4	

Boom extension sequence														%
Tele 1	0	0	45	45	90	45	90	45	90	90	90	90	90	100
Tele 2	0	0	0	45	45	45	90	45	45	90	90	90	90	100
Tele 3	0	0	0	0	0	45	0	45	45	45	90	90	90	100
Tele 4	0	0	0	0	0	0	0	45	45	45	45	90	90	100

- ¹⁾ with add. outrigger and double hook block
- ²⁾ static test load only
- ^{*} with heavy-lift attachment
- ^{**} with heavy-lift attachment and double hook block

Lifting capacities main boom in 1,000 lb

211,500 lb



360°

85%

Radius ft	Main boom											
	49.0 ft	65.0 ft	81.0 ft	97.0 ft	97.0 ft	113.0 ft	113.0 ft	129.0 ft	144.5 ft	160.5 ft	176.5 ft	190.0 ft
	1,000 lb											
10	589.0**	-	-	-	-	-	-	-	-	-	-	-
11	563.0**	559.0**	-	-	-	-	-	-	-	-	-	-
13	516.0**	514.0**	-	-	-	-	-	-	-	-	-	-
15	474.0**	472.0**	-	-	-	-	-	-	-	-	-	-
16	458.0*	456.0*	401.0*	300.0	343.0*	-	-	-	-	-	-	-
19	411.0*	409.0*	368.0*	276.0	329.0*	253.0	255.0	-	-	-	-	-
23	361.0*	358.0*	325.0*	248.0	306.0	229.0	242.0	209.0	-	-	-	-
26	328.0*	326.0*	297.0	232.0	284.0	212.0	230.0	201.0	167.0	-	-	-
29	304.0	300.0	282.0	216.0	267.0	200.0	218.0	189.5	159.5	135.0	-	-
33	272.0	270.0	254.0	195.0	241.0	181.0	204.0	175.5	149.0	128.5	102.0	-
39	238.0	233.0	226.0	170.0	215.0	155.5	184.0	155.5	135.0	120.5	98.0	84.0
46	-	198.0	194.5	145.0	187.0	133.0	162.5	134.0	121.0	109.0	92.5	79.0
52	-	172.5	172.5	129.0	167.0	118.0	146.5	121.0	111.0	99.5	86.0	75.0
59	-	-	144.5	110.0	145.5	105.5	132.0	107.0	101.0	89.0	80.5	70.5
65	-	-	124.0	98.0	126.5	95.5	122.0	97.5	93.0	82.0	75.0	65.0
72	-	-	-	84.0	107.0	85.0	110.5	88.0	84.0	76.0	69.5	61.0
79	-	-	-	72.0	93.0	76.5	96.5	81.0	76.5	70.0	64.0	57.1
85	-	-	-	63.5	82.0	69.5	86.0	74.0	70.5	66.0	60.0	53.9
92	-	-	-	-	-	64.5	75.5	67.0	63.5	61.5	55.9	49.7
98	-	-	-	-	-	57.8	68.5	61.0	58.9	56.5	52.7	46.9
105	-	-	-	-	-	-	-	55.1	54.0	52.2	49.3	43.6
111	-	-	-	-	-	-	-	51.0	49.9	48.8	46.5	41.2
118	-	-	-	-	-	-	-	45.5	45.4	45.4	43.0	38.8
124	-	-	-	-	-	-	-	-	42.8	42.8	40.8	36.4
131	-	-	-	-	-	-	-	-	39.7	39.7	38.6	34.4
138	-	-	-	-	-	-	-	-	-	37.4	36.3	32.1
144	-	-	-	-	-	-	-	-	-	-	34.2	30.9
151	-	-	-	-	-	-	-	-	-	-	32.1	29.0
157	-	-	-	-	-	-	-	-	-	-	30.5	27.6
164	-	-	-	-	-	-	-	-	-	-	-	26.4

Boom extension sequence												%
Tale 1	0	45	45	90	45	90	45	90	90	90	90	100
Tale 2	0	0	45	45	45	90	45	45	90	90	90	100
Tale 3	0	0	0	0	45	0	45	45	45	90	90	100
Tale 4	0	0	0	0	0	0	45	45	45	45	90	100

- * with heavy-lift attachment
- ** with heavy-lift attachment and double hook block

Lifting capacities main boom in 1,000 lb

154,000 lb



360°

85%

Radius ft	Main boom											
	49.0 ft	65.0 ft	81.0 ft	97.0 ft	97.0 ft	113.0 ft	113.0 ft	129.0 ft	144.5 ft	160.5 ft	176.5 ft	190.0 ft
	1,000 lb											
10	579.0**	-	-	-	-	-	-	-	-	-	-	-
11	553.0**	548.0**	-	-	-	-	-	-	-	-	-	-
13	505.0**	503.0**	-	-	-	-	-	-	-	-	-	-
15	467.0**	465.0**	-	-	-	-	-	-	-	-	-	-
16	448.0*	446.0*	401.0*	300.0	343.0*	-	-	-	-	-	-	-
19	404.0*	400.0*	368.0*	276.0	329.0*	253.0	255.0	-	-	-	-	-
23	352.0*	350.0*	325.0*	248.0	306.0	229.0	242.0	209.0	-	-	-	-
26	324.0*	321.0	297.0	232.0	284.0	212.0	230.0	201.0	167.0	-	-	-
29	297.0	295.0	282.0	216.0	267.0	200.0	218.0	189.5	159.5	135.0	-	-
33	265.0	263.0	254.0	195.0	241.0	181.0	204.0	175.5	149.0	128.5	102.0	-
39	223.0	219.0	220.0	170.0	215.0	155.5	184.0	155.5	135.0	120.5	98.0	84.0
46	-	168.0	169.0	145.0	172.5	133.0	162.5	134.0	121.0	109.0	92.5	79.0
52	-	137.0	137.0	129.0	140.0	118.0	144.5	121.0	111.0	99.5	86.0	75.0
59	-	-	110.0	108.0	113.5	105.5	118.0	107.0	101.0	89.0	80.5	70.5
65	-	-	93.0	91.0	97.5	91.5	100.5	97.5	93.0	82.0	75.0	65.0
72	-	-	-	76.0	80.5	77.5	85.0	81.5	81.5	76.0	69.5	61.0
79	-	-	-	65.5	70.0	65.5	73.5	71.0	71.0	70.0	64.0	57.1
85	-	-	-	57.5	62.0	58.1	65.5	63.0	63.0	64.5	60.0	53.9
92	-	-	-	-	-	49.9	57.4	54.7	54.9	56.5	55.9	49.7
98	-	-	-	-	-	43.6	51.5	49.1	49.1	50.6	52.4	46.9
105	-	-	-	-	-	-	-	42.9	42.9	44.7	46.7	43.6
111	-	-	-	-	-	-	-	38.3	38.3	40.1	42.2	41.2
118	-	-	-	-	-	-	-	34.0	33.5	35.3	37.5	37.5
124	-	-	-	-	-	-	-	-	30.1	31.7	33.9	33.9
131	-	-	-	-	-	-	-	-	26.5	27.9	30.1	30.1
138	-	-	-	-	-	-	-	-	-	24.5	26.8	26.8
144	-	-	-	-	-	-	-	-	-	-	24.1	24.1
151	-	-	-	-	-	-	-	-	-	-	21.7	21.3
157	-	-	-	-	-	-	-	-	-	-	19.5	19.3
164	-	-	-	-	-	-	-	-	-	-	-	17.2

Boom extension sequence													%
Tele 1	0	45	45	90	45	90	45	90	90	90	90	90	100
Tele 2	0	0	45	45	45	90	45	45	90	90	90	90	100
Tele 3	0	0	0	0	45	0	45	45	45	90	90	90	100
Tele 4	0	0	0	0	0	0	45	45	45	45	90	90	100

* with heavy-lift attachment
 ** with heavy-lift attachment and double hook block

Lifting capacities main boom in 1,000 lb

97,500 lb



360°

85%

Radius ft	Main boom											
	49.0 ft	65.0 ft	81.0 ft	97.0 ft	97.0 ft	113.0 ft	113.0 ft	129.0 ft	144.5 ft	160.5 ft	176.5 ft	190.0 ft
	1,000 lb											
10	567.0**	-	-	-	-	-	-	-	-	-	-	-
11	543.0**	540.0**	-	-	-	-	-	-	-	-	-	-
13	496.0**	494.0**	-	-	-	-	-	-	-	-	-	-
15	458.0**	454.0**	-	-	-	-	-	-	-	-	-	-
16	441.0*	438.0*	401.0*	300.0	343.0*	-	-	-	-	-	-	-
19	395.0*	393.0*	368.0*	276.0	329.0*	253.0	255.0	-	-	-	-	-
23	345.0*	343.0*	325.0*	248.0	306.0	229.0	242.0	209.0	-	-	-	-
26	311.0	309.0	297.0	232.0	284.0	212.0	230.0	201.0	167.0	-	-	-
29	279.0	275.0	275.0	216.0	267.0	200.0	218.0	189.5	159.5	135.0	-	-
33	233.0	227.0	229.0	195.0	233.0	181.0	204.0	175.5	149.0	128.5	102.0	-
39	170.0	165.5	167.0	162.5	170.0	155.5	173.5	155.5	135.0	120.5	98.0	84.0
46	-	119.5	122.0	118.5	125.0	119.5	130.5	127.5	121.0	109.0	92.5	79.0
52	-	96.5	97.5	95.5	101.0	96.5	105.5	102.0	101.5	99.5	86.0	75.0
59	-	-	77.0	75.0	79.5	76.0	85.0	81.5	81.5	82.5	80.5	70.5
65	-	-	65.0	63.0	67.0	63.5	71.5	69.5	69.5	70.5	72.0	65.0
72	-	-	-	51.2	56.4	52.3	60.0	57.8	58.0	59.7	62.0	61.0
79	-	-	-	41.6	47.1	42.4	50.8	48.4	48.6	50.2	52.4	52.4
85	-	-	-	35.1	40.8	35.8	44.2	41.5	41.7	43.5	45.7	45.9
92	-	-	-	-	-	29.4	37.5	34.9	35.1	36.9	39.3	39.3
98	-	-	-	-	-	24.8	32.5	30.1	30.3	32.0	34.3	34.3
105	-	-	-	-	-	-	-	25.5	25.5	27.3	29.5	29.5
111	-	-	-	-	-	-	-	22.1	21.7	23.5	25.9	25.9
118	-	-	-	-	-	-	-	18.5	18.3	19.8	22.1	22.1
124	-	-	-	-	-	-	-	-	15.5	17.0	19.2	19.2
131	-	-	-	-	-	-	-	-	12.8	13.9	16.4	16.4
138	-	-	-	-	-	-	-	-	-	11.6	13.6	13.6
144	-	-	-	-	-	-	-	-	-	-	11.7	11.7
151	-	-	-	-	-	-	-	-	-	-	9.6	9.6
157	-	-	-	-	-	-	-	-	-	-	8.0	8.0
164	-	-	-	-	-	-	-	-	-	-	-	6.4



Boom extension sequence

												%	
Tale 1	0	45	45	90	45	90	45	90	90	90	90	90	100
Tale 2	0	0	45	45	45	90	45	45	90	90	90	90	100
Tale 3	0	0	0	0	45	0	45	45	45	90	90	90	100
Tale 4	0	0	0	0	0	0	45	45	45	45	90	90	100

* with heavy-lift attachment

** with heavy-lift attachment and double hook block

Lifting capacities main boom in 1,000 lb

0 lb   360° 85% %

Radius ft	Main boom					ft
	49.0 ft	65.0 ft	81.0 ft	97.0 ft	113.0 ft	
	1,000 lb					
10	485.0**	-	-	-	-	
11	462.0*	429.0*	-	-	-	
13	413.0*	384.0*	-	-	-	
15	367.0*	336.0*	-	-	-	
16	344.0*	311.0	310.0	246.0	-	
19	274.0	249.0	249.0	216.0	220.0	
23	179.0	168.0	165.5	158.0	156.0	
26	129.5	121.5	121.5	114.5	113.5	
29	99.5	92.5	92.5	87.0	86.0	
33	72.0	65.0	65.0	62.0	61.5	
39	48.6	42.8	43.0	39.5	39.7	
46	-	25.6	26.1	23.0	23.2	
52	-	17.0	17.2	14.5	15.0	
59	-	-	9.9	7.3	8.2	
65	-	-	4.7	-	3.1	

Boom extension sequence					%
Tete 1	0	45	45	90	90
Tete 2	0	0	45	45	90
Tete 3	0	0	0	0	0
Tete 4	0	0	0	0	0

* with heavy-lift attachment

** with heavy-lift attachment and double hook block

Working ranges fixed fly jib

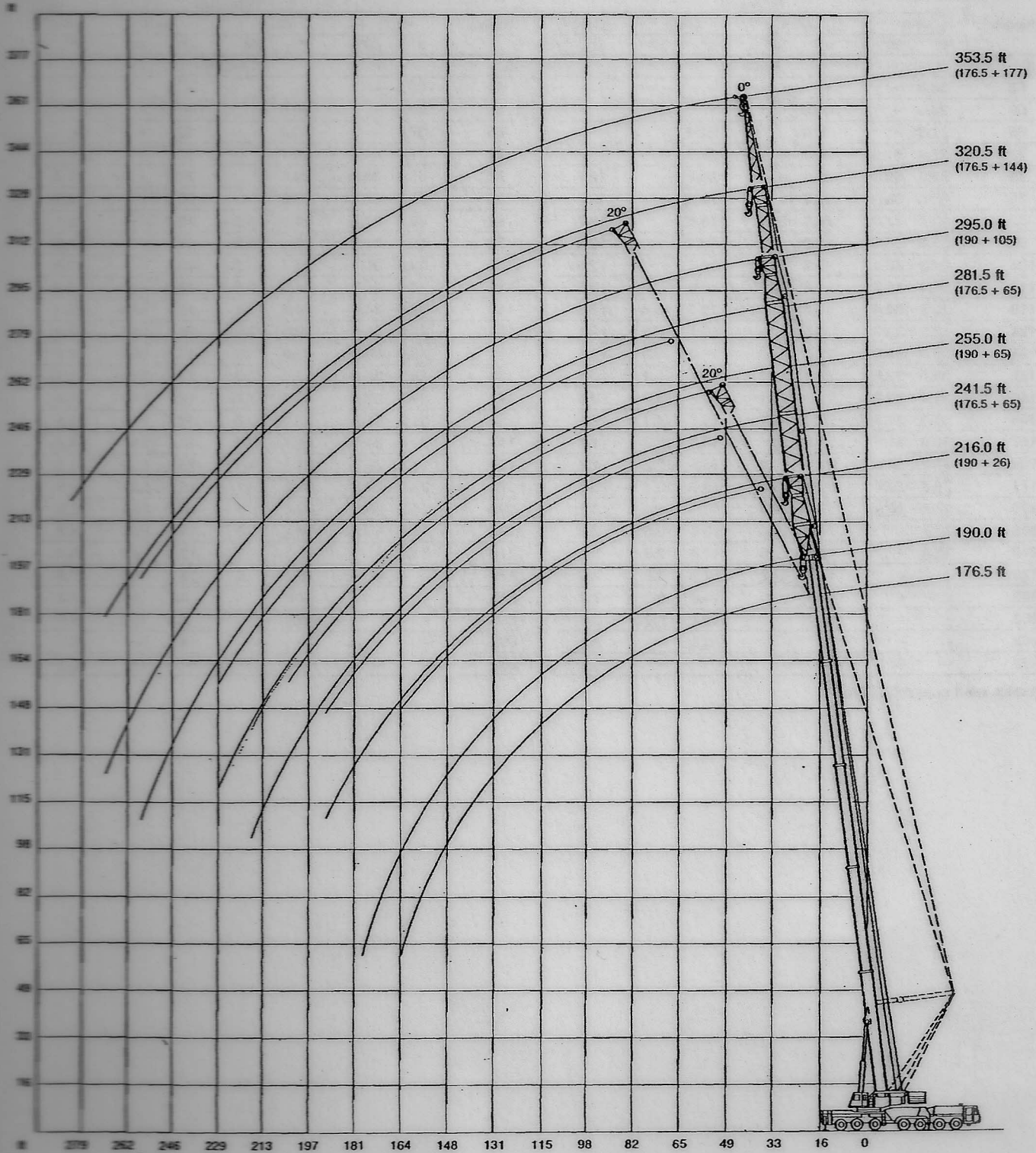

Lifting capacities fixed fly jib with Superlift in 1,000 lb

Main boom: 176.5 ft

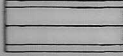
269,000 lb  360° 85%

Radius ft	Extension							
	65 ft		105 ft		144 ft		177 ft ¹⁾	
	0°	20°	0°	20°	0°	20°	0°	20°
	1,000 lb							
52	38.8	-	-	-	-	-	-	-
59	38.3	-	30.8	-	-	-	-	-
65	37.9	-	30.0	-	21.4	-	-	-
72	37.4	41.0	29.1	-	20.9	-	-	-
79	37.0	39.8	28.1	-	20.7	-	12.7	-
85	36.6	38.8	27.5	-	20.3	-	12.7	-
92	35.9	37.6	26.8	25.5	19.8	-	12.7	-
98	35.3	36.8	26.0	24.9	19.4	-	12.5	-
105	34.8	36.1	25.7	24.2	19.1	-	12.5	-
111	34.4	35.3	24.9	23.8	18.9	-	12.3	-
118	33.9	34.4	24.2	23.1	18.5	15.4	12.3	-
124	33.5	33.7	23.8	22.5	18.1	15.2	12.1	-
131	33.0	33.0	23.3	22.0	17.6	15.2	12.1	-
138	32.3	32.6	22.9	21.5	17.4	15.1	12.1	-
144	31.7	32.0	22.5	21.1	17.2	14.7	12.1	-
151	31.3	31.5	22.0	20.7	16.7	14.1	12.1	-
157	30.8	31.1	21.6	20.3	16.3	13.7	11.7	-
164	30.2	30.6	21.1	19.8	15.8	13.2	11.2	-
177	29.3	29.7	20.2	19.1	15.0	12.1	10.5	-
190	27.5	28.9	19.6	18.5	14.3	11.4	9.9	-
203	23.7	-	18.9	18.0	13.6	10.6	9.2	-
216	17.4	-	18.5	17.6	12.8	9.9	8.4	-
229	-	-	17.8	17.2	12.1	9.2	7.9	-
243	-	-	14.4	-	11.2	8.8	7.2	-
256	-	-	8.7	-	10.7	8.3	6.6	-
269	-	-	-	-	10.3	-	6.1	-
282	-	-	-	-	-	-	5.5	-

¹⁾ max. wind speed 13.3 mph

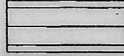
211,500 lb  360° 85%

Radius ft	Extension							
	65 ft		105 ft		144 ft		177 ft ¹⁾	
	0°	20°	0°	20°	0°	20°	0°	20°
	1,000 lb							
52	38.8	-	-	-	-	-	-	-
59	38.3	-	30.8	-	-	-	-	-
65	37.9	-	30.0	-	21.4	-	-	-
72	37.4	41.0	29.1	-	20.9	-	-	-
79	37.0	39.8	28.1	-	20.7	-	12.7	-
85	36.6	38.8	27.5	-	20.3	-	12.7	-
92	35.9	37.6	26.8	25.5	19.8	-	12.7	-
98	35.3	36.8	26.0	24.9	19.4	-	12.5	-
105	34.8	36.1	25.7	24.2	19.1	-	12.5	-
111	34.4	35.3	24.9	23.8	18.9	-	12.3	-
118	33.9	34.4	24.2	23.1	18.5	15.4	12.3	-
124	33.5	33.7	23.8	22.5	18.1	15.2	12.1	-
131	33.0	33.0	23.3	22.0	17.6	15.2	12.1	-
138	32.3	32.6	22.9	21.5	17.4	15.1	12.1	-
144	31.7	32.0	22.5	21.1	17.2	14.7	12.1	-
151	31.2	31.5	22.0	20.7	16.7	14.1	12.1	-
157	30.0	31.1	21.6	20.3	16.3	13.7	11.7	-
164	27.3	29.7	21.1	19.8	15.8	13.2	11.2	-
177	22.5	24.5	20.2	19.1	15.0	12.1	10.5	-
190	18.3	20.1	19.4	18.5	14.3	11.4	9.9	-
203	14.8	-	16.1	18.0	13.6	10.6	9.2	-
216	11.8	-	13.1	15.5	12.8	9.9	8.4	-
229	-	-	10.2	12.5	11.1	9.2	7.9	-
243	-	-	7.9	-	8.7	8.8	7.2	-
256	-	-	5.9	-	6.8	8.3	6.6	-
269	-	-	-	-	4.8	-	6.1	-
282	-	-	-	-	-	-	5.3	-

Lifting capacities fixed fly jib with Superlift in 1,000 lb

Main boom: 190.0 ft

269,000 lb  360° 85%

Radius ft	Extension					
	26 ft		65 ft		105 ft	
	0°	20°	0°	20°	0°	
	1,000 lb					
46	55.1	-	-	-	-	-
52	54.5	57.6	35.9	-	-	-
59	54.0	56.6	35.2	-	-	22.4
65	53.4	55.8	34.4	-	-	22.4
72	53.1	54.9	33.5	35.2	-	22.4
79	51.9	53.9	33.0	34.3	-	22.0
85	50.9	52.7	32.4	33.5	-	22.0
92	50.0	52.0	31.5	32.8	-	21.8
98	49.2	50.9	31.1	32.2	-	21.6
105	48.5	50.0	30.6	31.3	-	21.3
111	47.8	49.2	30.0	30.6	-	21.1
118	47.1	48.2	29.5	30.2	-	20.7
124	46.7	47.4	29.1	29.6	-	20.3
131	46.3	46.9	28.6	29.1	-	20.0
138	45.1	46.2	28.2	28.4	-	19.6
144	44.3	45.0	28.0	28.0	-	19.4
151	41.8	42.5	27.5	27.5	-	18.9
157	38.8	39.6	27.3	27.3	-	18.7
164	35.2	36.1	26.8	26.8	-	18.3
177	29.8	-	26.2	26.2	-	17.8
190	24.1	-	24.0	24.9	-	17.2
203	-	-	20.4	21.7	-	16.7
216	-	-	17.3	-	-	16.1
229	-	-	12.5	-	-	15.6
243	-	-	-	-	-	14.5
256	-	-	-	-	-	11.6
269	-	-	-	-	-	6.4

211,500 lb  360° 85%

Radius ft	Extension					
	26 ft		65 ft		105 ft	
	0°	20°	0°	20°	0°	
	1,000 lb					
46	55.1	-	-	-	-	-
52	54.5	57.6	35.9	-	-	-
59	54.0	56.6	35.2	-	-	22.4
65	53.4	55.8	34.4	-	-	22.4
72	53.1	54.9	33.5	35.2	-	22.4
79	51.9	53.9	33.0	34.3	-	22.0
85	50.9	52.7	32.4	33.5	-	22.0
92	50.0	52.0	31.5	32.8	-	21.8
98	49.2	50.9	31.1	32.2	-	21.6
105	48.5	50.0	30.6	31.3	-	21.3
111	47.8	49.2	30.0	30.6	-	21.1
118	47.1	48.2	29.5	30.2	-	20.7
124	45.5	47.2	29.1	29.6	-	20.3
131	41.1	42.7	28.6	29.1	-	20.0
138	36.9	38.4	28.2	28.4	-	19.6
144	33.7	35.0	28.0	28.0	-	19.4
151	30.1	31.2	27.5	27.5	-	18.9
157	27.5	28.4	27.3	27.3	-	18.7
164	24.4	25.1	26.6	26.8	-	18.3
177	19.9	-	22.1	24.5	-	17.8
190	15.7	-	18.1	20.1	-	17.2
203	-	-	14.6	16.2	-	15.4
216	-	-	11.5	-	-	12.6
229	-	-	8.9	-	-	9.8
243	-	-	-	-	-	7.4
256	-	-	-	-	-	5.2
269	-	-	-	-	-	3.5

Lifting capacities fixed fly jib in 1,000 lb

Main boom: 176.5 ft

211,500 lb  360° 85%

Radius	Extension							
	65 ft		105 ft		144 ft		177 ft ¹⁾	
	0°	20°	0°	20°	0°	20°	0°	20°
	1,000 lb							
52	36.2	-	-	-	-	-	-	-
59	34.4	-	26.4	-	-	-	-	-
65	32.9	-	25.2	-	17.2	-	-	-
72	31.3	29.5	23.8	-	16.3	-	-	-
79	29.9	28.3	22.6	-	15.6	-	11.0	-
85	28.7	27.3	21.6	-	15.0	-	10.6	-
92	27.5	25.9	20.7	-	14.3	-	10.1	-
98	26.5	24.7	19.8	18.1	13.7	-	9.7	-
105	25.3	24.0	18.9	17.4	13.0	-	9.0	-
111	24.5	23.4	18.1	16.6	12.4	-	8.6	-
118	23.3	22.5	17.2	15.8	11.6	-	8.1	-
124	22.5	21.6	16.6	15.2	11.2	11.5	7.9	-
131	21.4	20.9	15.8	14.7	10.8	11.0	7.5	-
138	20.6	20.2	15.1	14.0	10.3	10.5	7.0	-
144	19.8	19.6	14.5	13.6	9.7	9.9	6.8	-
151	18.9	18.9	13.8	13.0	9.2	9.4	6.3	-
157	18.1	18.3	13.2	12.5	8.8	9.0	6.1	-
164	17.4	17.6	12.7	12.1	8.3	8.8	5.7	-
177	15.8	16.3	11.4	11.2	7.7	7.9	5.2	-
190	14.3	15.0	10.6	10.3	6.8	7.2	4.8	-
203	12.8	13.7	9.7	9.7	5.9	6.8	4.2	-
216	11.5	-	8.6	8.8	5.3	6.2	3.7	-
229	-	-	7.7	8.1	4.2	5.5	3.3	-
243	-	-	6.8	-	3.7	5.0	2.6	-
256	-	-	5.7	-	2.8	4.6	-	-
269	-	-	-	-	-	3.9	-	-

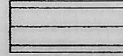
154,000 lb  360° 85%

Radius	Extension							
	65 ft		105 ft		144 ft		177 ft ¹⁾	
	0°	20°	0°	20°	0°	20°	0°	20°
	1,000 lb							
52	36.2	-	-	-	-	-	-	-
59	34.4	-	26.4	-	-	-	-	-
65	32.9	-	25.2	-	17.2	-	-	-
72	31.3	29.5	23.8	-	16.3	-	-	-
79	29.9	28.3	22.6	-	15.6	-	11.0	-
85	28.7	27.3	21.6	-	15.0	-	10.6	-
92	27.5	25.9	20.7	-	14.3	-	10.1	-
98	26.5	24.7	19.8	18.1	13.7	-	9.7	-
105	25.3	24.0	18.9	17.4	13.0	-	9.0	-
111	24.5	23.4	18.1	16.6	12.4	-	8.6	-
118	23.3	22.5	17.2	15.8	11.6	-	8.1	-
124	22.5	21.6	16.6	15.2	11.2	11.5	7.9	-
131	21.4	20.9	15.8	14.7	10.8	11.0	7.5	-
138	20.6	20.2	15.1	14.0	10.3	10.5	7.0	-
144	19.8	19.6	14.5	13.6	9.7	9.9	6.8	-
151	18.9	18.9	13.8	13.0	9.2	9.4	6.3	-
157	18.1	18.3	13.2	12.5	8.8	9.0	6.1	-
164	17.2	17.6	12.7	12.1	8.3	8.8	5.7	-
177	13.4	15.4	11.4	11.2	7.7	7.9	5.2	-
190	10.2	11.7	10.6	10.3	6.8	7.2	4.8	-
203	7.5	8.9	8.2	9.7	5.9	6.8	4.2	-
216	5.1	-	6.0	8.2	5.3	6.2	3.7	-
229	-	-	3.8	5.8	4.2	5.5	3.3	-
243	-	-	1.9	-	2.3	5.0	2.6	-
256	-	-	-	-	-	3.2	-	-

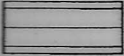
97,000 lb  360° 85%

Radius	Extension							
	65 ft		105 ft		144 ft		177 ft ¹⁾	
	0°	20°	0°	20°	0°	20°	0°	20°
	1,000 lb							
52	36.2	-	-	-	-	-	-	-
59	34.4	-	26.4	-	-	-	-	-
65	32.9	-	25.2	-	17.2	-	-	-
72	31.3	29.5	23.8	-	16.3	-	-	-
79	29.9	28.3	22.6	-	15.6	-	11.0	-
85	28.7	27.3	21.6	-	15.0	-	10.6	-
92	27.5	25.9	20.7	-	14.3	-	10.1	-
98	26.5	24.7	19.8	18.1	13.7	-	9.7	-
105	25.3	24.0	18.9	17.4	13.0	-	9.0	-
111	24.5	23.4	18.1	16.6	12.4	-	8.6	-
118	22.9	22.5	17.2	15.8	11.6	-	8.1	-
124	20.1	21.6	16.6	15.2	11.2	11.5	7.9	-
131	17.0	20.7	15.8	14.7	10.8	11.0	7.5	-
138	14.4	17.9	15.1	14.0	10.3	10.5	7.0	-
144	12.4	15.5	13.3	13.6	9.7	9.9	6.8	-
151	10.1	12.9	11.2	13.0	9.2	9.4	6.3	-
157	8.3	11.1	9.4	12.5	8.8	9.0	6.1	-
164	6.4	9.0	7.5	11.6	8.1	8.8	5.7	-
177	3.5	5.5	4.4	8.2	5.3	7.9	5.2	-
190	-	2.7	2.0	5.3	2.7	7.2	4.8	-
203	-	-	-	2.5	-	4.5	2.5	-
216	-	-	-	-	-	2.2	-	-

¹⁾ max. wind speed 13.3 mph

Lifting capacities fixed fly jib in 1,000 lb

Main boom: 190.0 ft

211,500 lb  360° 85%

Radius ft	Extension				
	26 ft		65 ft		105 ft
	0°	20°	0°	20°	0°
	1,000 lb				
46	56.6	-	-	-	-
52	53.1	51.1	33.2	-	-
59	49.6	47.8	31.3	-	22.2
65	47.2	45.6	29.7	-	20.4
72	44.3	43.0	28.4	27.3	19.4
79	41.8	40.7	27.2	25.9	18.4
85	39.7	38.8	26.0	25.1	17.6
92	37.4	36.7	24.8	24.0	16.7
98	35.4	34.9	23.8	23.2	15.9
105	33.2	33.0	22.9	22.2	15.2
111	31.6	31.6	21.9	21.4	14.6
118	29.7	29.7	20.9	20.5	13.9
124	28.1	28.3	20.1	19.9	13.4
131	26.5	26.7	19.4	19.2	12.8
138	24.6	25.3	18.4	18.2	12.1
144	23.2	23.8	17.6	17.6	11.7
151	21.5	22.4	16.9	16.9	11.2
157	20.1	21.2	16.3	16.3	10.8
164	18.5	19.8	15.6	15.6	10.3
177	15.6	17.2	14.3	14.3	9.7
190	13.0	-	13.0	13.0	8.8
203	-	-	11.9	11.9	7.9
216	-	-	10.6	-	7.0
229	-	-	9.5	-	6.2
243	-	-	-	-	5.2
256	-	-	-	-	3.9

154,000 lb  360° 85%

Radius ft	Extension				
	26 ft		65 ft		105 ft
	0°	20°	0°	20°	0°
	1,000 lb				
46	56.6	-	-	-	-
52	53.1	51.1	33.2	-	-
59	49.6	47.8	31.3	-	22.2
65	47.2	45.6	29.7	-	20.4
72	44.3	43.0	28.4	27.3	19.4
79	41.8	40.7	27.2	25.9	18.4
85	39.7	38.8	26.0	25.1	17.6
92	37.4	36.7	24.8	24.0	16.7
98	35.4	34.9	23.8	23.2	15.9
105	33.2	33.0	22.9	22.2	15.2
111	31.6	31.6	21.9	21.4	14.6
118	29.7	29.7	20.9	20.5	13.9
124	28.1	28.3	20.1	19.9	13.4
131	26.5	26.7	19.4	19.2	12.8
138	24.6	25.2	18.4	18.2	12.1
144	22.1	23.0	17.6	17.6	11.7
151	19.3	20.2	16.6	16.9	11.2
157	17.1	18.2	16.3	16.3	10.8
164	14.7	15.6	15.6	15.6	10.3
177	11.0	11.7	13.0	14.3	9.7
190	8.0	-	9.7	11.5	8.8
203	-	-	7.1	8.6	7.7
216	-	-	4.5	-	5.3
229	-	-	2.5	-	3.4

97,000 lb  360° 85%

Radius ft	Extension				
	26 ft		65 ft		105 ft
	0°	20°	0°	20°	0°
	1,000 lb				
46	56.6	-	-	-	-
52	53.1	51.1	33.2	-	-
59	49.6	47.8	31.3	-	22.2
65	47.2	45.6	29.7	-	20.4
72	44.3	43.0	28.4	27.3	19.4
79	41.8	40.7	27.2	25.9	18.4
85	39.7	38.8	26.0	25.1	17.6
92	37.3	36.7	24.8	24.0	16.7
98	32.9	34.9	23.8	23.2	15.9
105	27.9	30.1	22.9	22.2	15.2
111	24.3	26.1	21.9	21.4	14.6
118	20.3	22.1	20.9	20.5	13.9
124	17.5	19.0	19.5	19.9	13.4
131	14.6	15.7	16.6	19.2	12.8
138	11.8	13.1	13.8	17.5	12.1
144	9.6	10.9	11.8	15.1	11.7
151	7.4	8.5	9.6	12.7	10.5
157	5.8	6.9	7.8	10.9	8.9
164	3.9	4.8	5.9	8.8	7.0
177	-	-	3.1	5.3	4.0
190	-	-	-	2.2	-

Working ranges luffing fly jib, main boom 82°

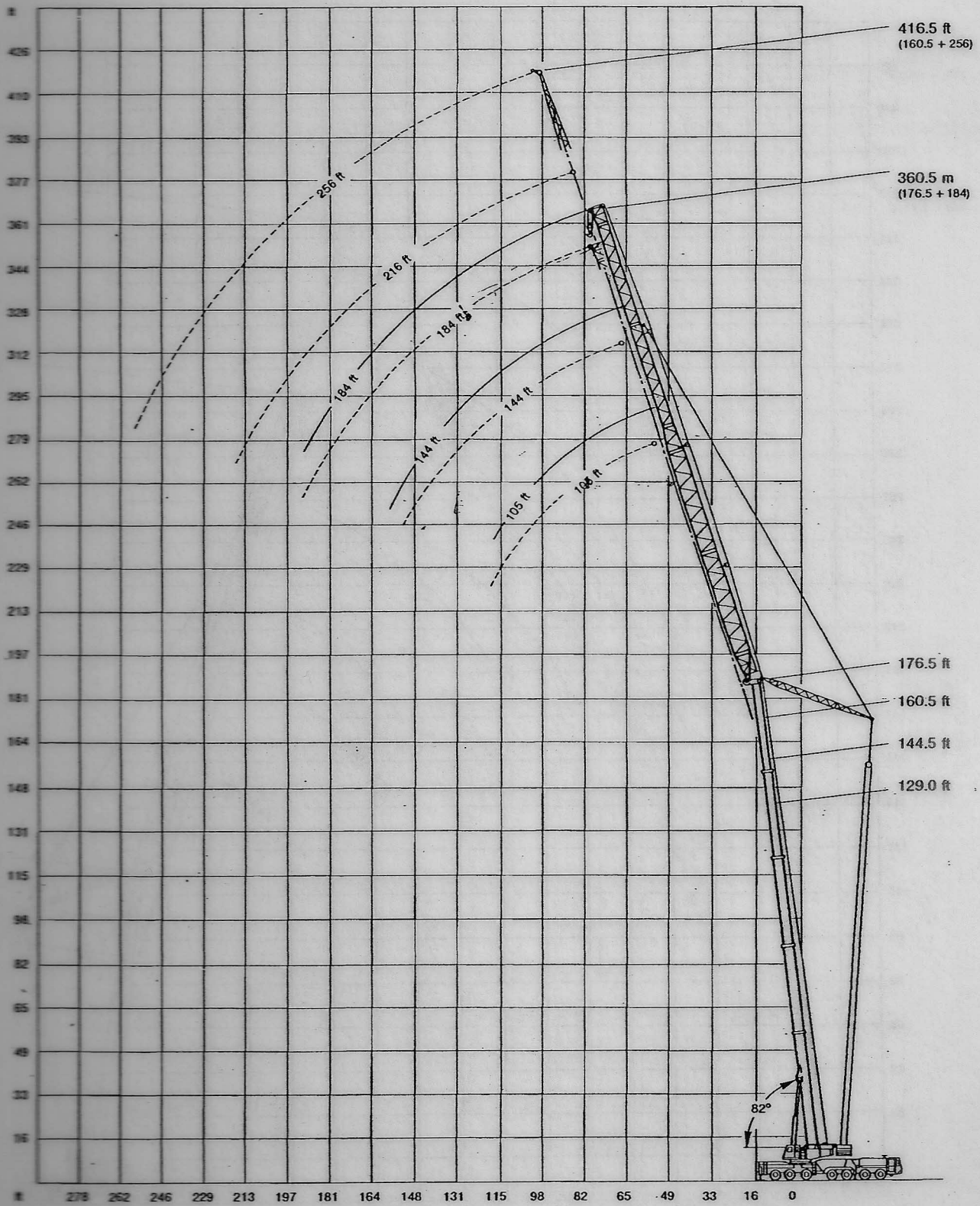

Working ranges luffing fly jib, main boom 82°

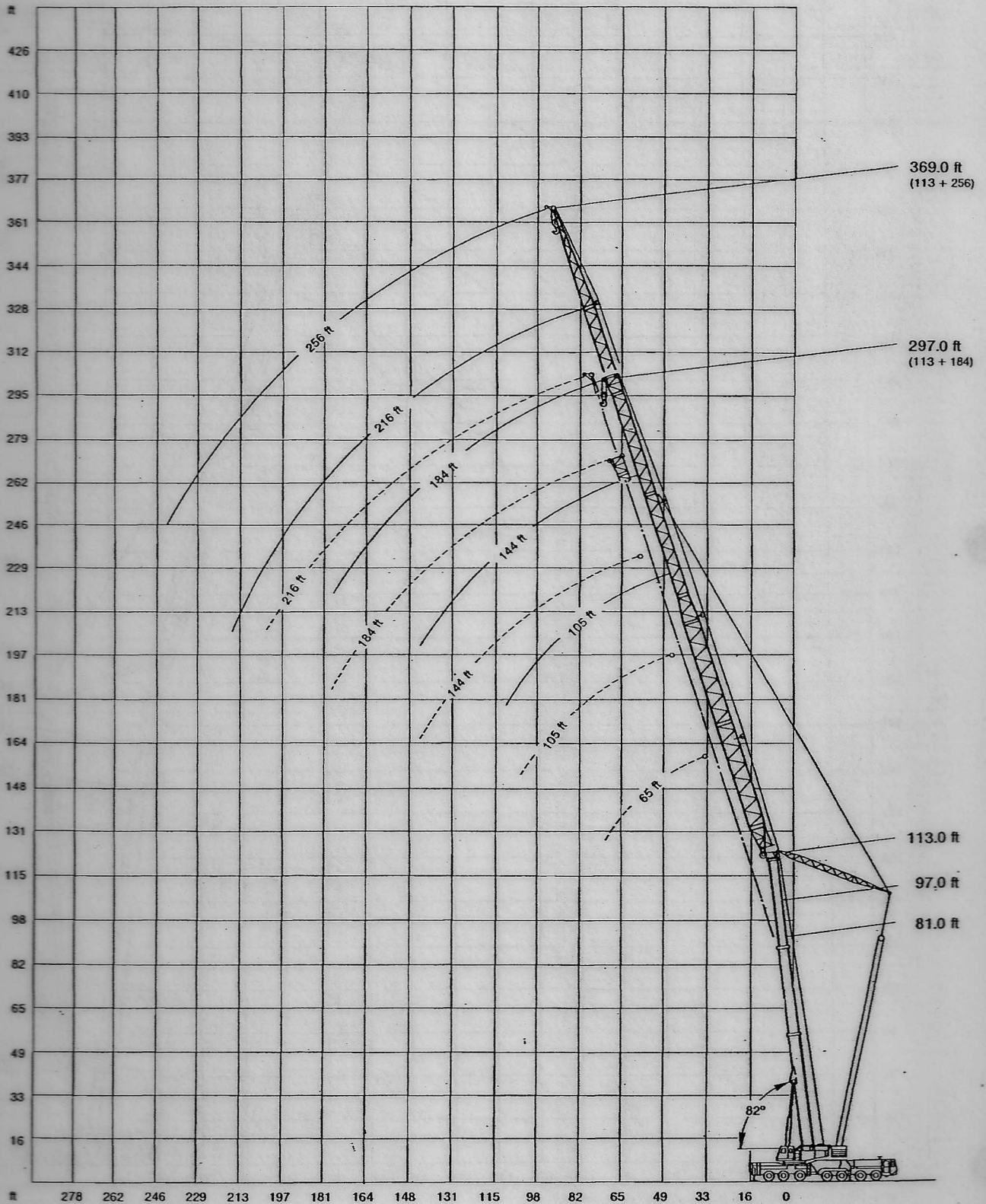

Working ranges luffing fly jib, main boom 70°

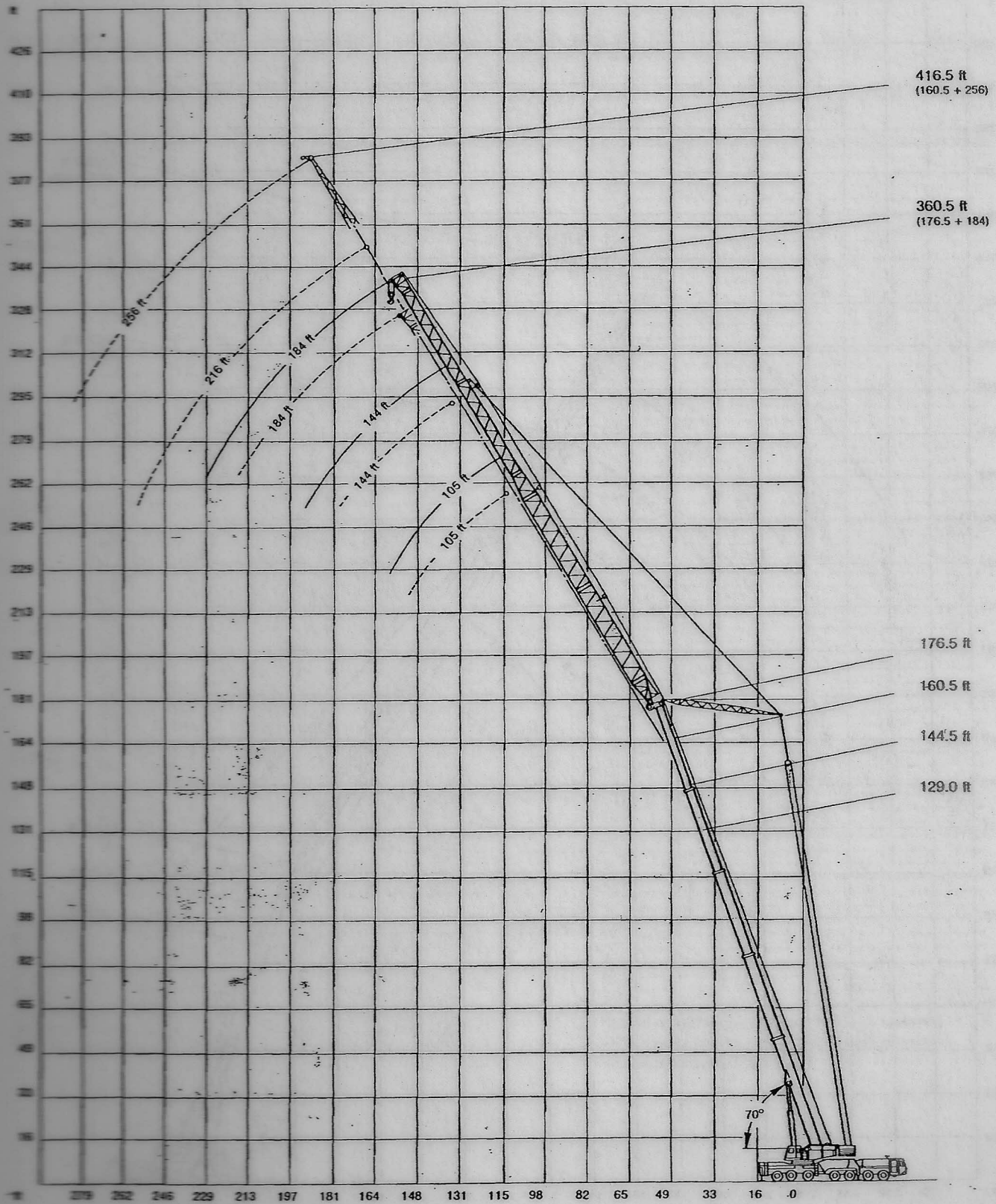

Working ranges luffing fly jib, main boom 70°

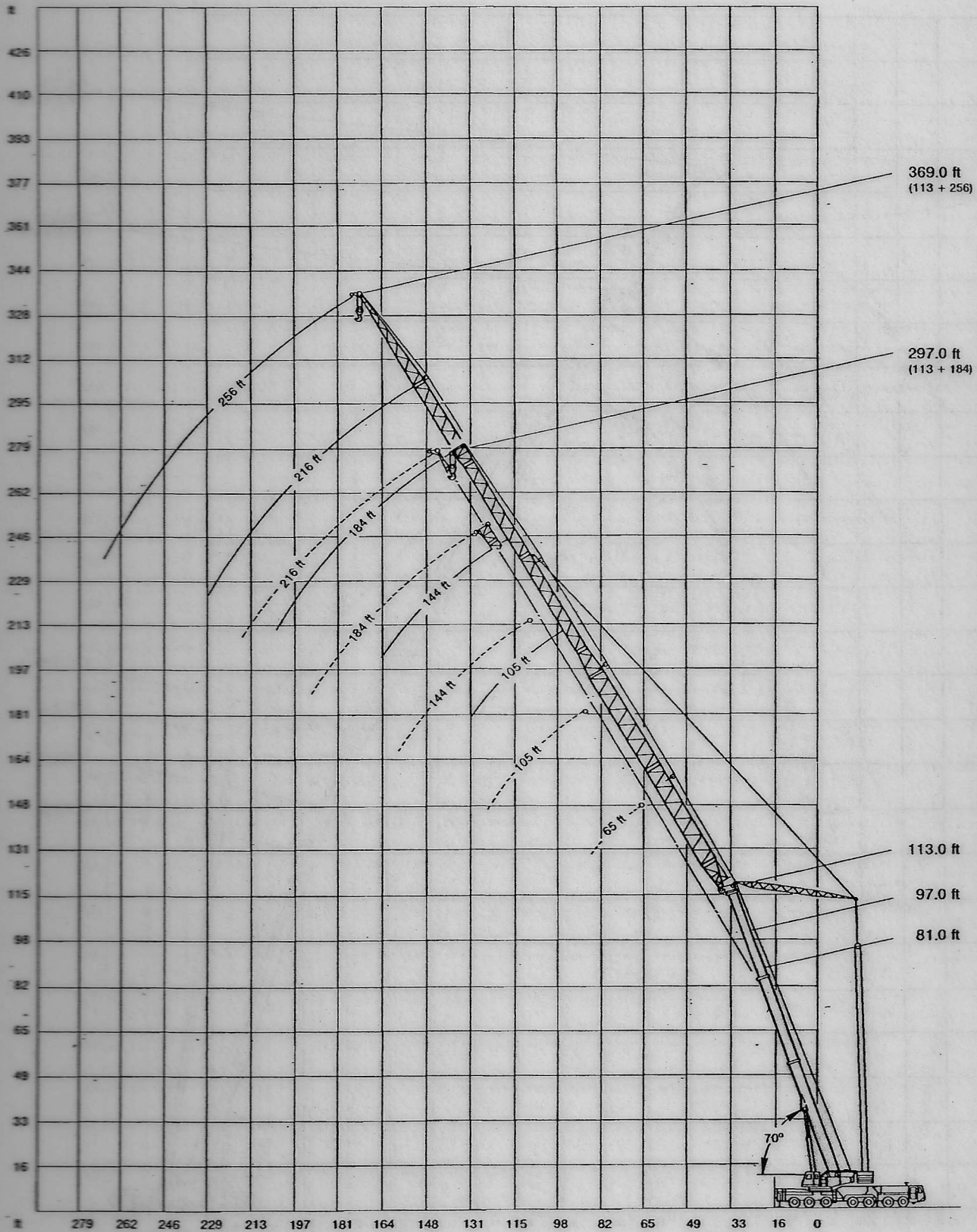

Lifting capacities luffing fly jib, main boom 70° in 1,000 lb

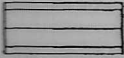
211,500 lb  360° 75%

Boom	Fly Jib						
	Radius	65 ft ¹⁾	105 ft ²⁾	144 ft	184 ft	216 ft ³⁾	256 ft ³⁾
			1,000 lb				
81.0 ft	69	113.0	-	-	-	-	-
	72	106.0	-	-	-	-	-
	79	95.5	-	-	-	-	-
	85	87.0	84.0	-	-	-	-
	92	-	75.5	-	-	-	-
	98	-	70.5	-	-	-	-
	105	-	64.5	62.5	-	-	-
	111	-	60.5	58.3	-	-	-
	118	-	55.8	54.5	-	-	-
	124	-	52.6	51.0	38.8	-	-
	131	-	-	47.5	38.3	-	-
	138	-	-	44.4	37.9	22.0	-
	144	-	-	42.0	37.5	21.6	-
	151	-	-	39.4	37.0	20.9	-
	157	-	-	37.4	36.2	20.5	-
	164	-	-	-	34.1	19.8	-
177	-	-	-	30.9	18.9	-	
190	-	-	-	27.8	18.0	-	
203	-	-	-	-	17.0	-	
216	-	-	-	-	16.1	-	
97.0 ft	92	-	73.5	-	-	-	-
	98	-	67.5	-	-	-	-
	105	-	62.0	-	-	-	-
	111	-	58.1	53.0	-	-	-
	118	-	53.6	50.7	-	-	-
	124	-	50.4	48.9	-	-	-
	131	-	-	46.1	30.8	-	-
	138	-	-	43.1	30.8	-	-
	144	-	-	40.7	30.8	-	-
	151	-	-	38.3	30.8	20.7	-
	157	-	-	36.3	30.8	20.5	-
	164	-	-	34.4	30.8	20.2	-
	177	-	-	-	29.7	19.4	-
	190	-	-	-	26.9	18.5	-
	203	-	-	-	24.5	17.6	-
	216	-	-	-	-	16.7	-
229	-	-	-	-	15.9	-	
113.0 ft	98	-	55.5	-	-	-	-
	105	-	52.6	-	-	-	-
	111	-	50.2	-	-	-	-
	118	-	47.6	41.2	-	-	-
	124	-	46.0	40.0	-	-	-
	131	-	44.3	38.6	-	-	-
	138	-	-	37.4	24.8	-	-
	144	-	-	36.2	24.4	17.8	-
	151	-	-	34.8	24.0	17.8	-
	157	-	-	34.0	23.8	17.8	-
	164	-	-	32.2	23.3	17.6	-
	177	-	-	-	22.7	17.2	15.6
	190	-	-	-	22.0	16.9	15.6
	203	-	-	-	21.6	16.7	15.4
	216	-	-	-	-	16.3	15.4
	229	-	-	-	-	15.8	15.2
243	-	-	-	-	-	15.2	
256	-	-	-	-	-	14.5	
269	-	-	-	-	-	13.2	

Boom extension sequence	%			
Boom	Tele 1	Tele 2	Tele 3	Tele 4
81.0 ft	45	45	0	0
97.0 ft	45	45	45	0
113.0 ft	90	90	0	0
129.0 ft	90	90	45	0
144.5 ft	90	90	90	0
160.5 ft	90	90	90	45
176.5 ft	90	90	90	90

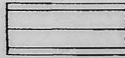
211,500 lb  360° 75%

Boom	Fly Jib					
	Radius	105 ft ²⁾	144 ft	184 ft	216 ft ³⁾	256 ft ³⁾
			1,000 lb			
129.0 ft	105	43.2	-	-	-	-
	111	41.5	-	-	-	-
	118	40.1	-	-	-	-
	124	38.7	35.4	-	-	-
	131	37.0	33.9	-	-	-
	138	35.6	32.5	-	-	-
	144	-	31.5	24.2	-	-
	151	-	30.4	23.5	-	-
	157	-	29.4	22.9	16.3	-
	164	-	28.2	22.4	16.3	-
	177	-	26.4	21.6	16.0	-
	190	-	-	20.7	16.0	12.3
	203	-	-	19.8	15.8	12.3
	216	-	-	-	15.8	12.3
	229	-	-	-	15.6	12.3
	243	-	-	-	15.4	12.3
256	-	-	-	-	12.3	
269	-	-	-	-	12.3	
282	-	-	-	-	11.4	
144.5 ft	111	32.1	-	-	-	-
	118	32.1	-	-	-	-
	124	31.0	-	-	-	-
	131	29.5	-	-	-	-
	138	28.4	27.5	-	-	-
	144	27.3	26.5	-	-	-
	151	-	25.5	21.8	-	-
	157	-	24.7	21.2	-	-
	164	-	24.0	20.5	-	-
	177	-	22.5	19.4	15.2	-
	190	-	-	18.3	14.7	7.9
	203	-	-	17.4	14.5	7.9
	216	-	-	16.3	14.1	7.9
	229	-	-	-	13.9	7.9
	243	-	-	-	13.6	7.9
	256	-	-	-	-	7.9
269	-	-	-	-	7.9	
282	-	-	-	-	7.9	
160.5 ft	124	29.2	-	-	-	-
	131	28.0	-	-	-	-
	138	27.0	21.1	-	-	-
	144	26.0	20.3	-	-	-
	151	25.1	19.8	-	-	-
	157	-	19.2	13.8	-	-
	164	-	18.7	13.8	-	-
	177	-	17.6	13.6	7.7	-
	190	-	-	13.4	7.7	4.4
	203	-	-	13.2	7.7	4.4
	216	-	-	15.5	7.7	4.4
	229	-	-	-	7.7	4.4
	243	-	-	-	7.7	4.4
	256	-	-	-	7.7	4.4
	269	-	-	-	-	4.4
	282	-	-	-	-	4.4
176.5 ft	131	24.2	-	-	-	-
	138	23.5	-	-	-	-
	144	22.9	14.3	-	-	-
	151	22.4	14.3	-	-	-
	157	21.8	14.3	-	-	-
	164	-	14.3	7.7	-	-
	177	-	14.3	7.7	-	-
	190	-	14.3	7.7	-	-
	203	-	-	7.7	-	-
	216	-	-	7.7	-	-
	229	-	-	7.7	-	-

- 1) Min. weight of hook block 3,960 lb (5 sheaves)
- 2) Min. weight of hook block 3,080 lb (3 sheaves)
- 3) max. wind speed 13.3 mph

Carrier

Drive/Steering:	14 x 6 x 12.
Frame:	Demag-built special main frame, fabricated from high-grade close-grained structural steel, with central pot to accommodate front outriggers.
Outriggers:	Four hydraulic outriggers with telescopic beams and jack legs, for 360° continuous rotation.
Engine:	Daimler-Benz OM 442 LA water-cooled 10 cylinder Diesel Engine. Output to DIN: 405 kW (550 HP). Fuel-tank capacity: 158 gallons.
Transmission:	ZF-Transmatic.
Axles:	Drive axles: 2, 3, 6. Steering axles: 1-4, 6+7, all axles hydro-pneumatically suspended and hydraulically blockable.
Wheels and tires:	14 disk-type wheels; 17.5 R 25 tires, plus one spare.
Steering:	Dual-circuit semiblock mechanical steering with hydraulic booster.
Brakes:	to EC standards.
Electrical equipment:	24-volt system.
Cab:	Rubber-mounted low-line three-man steel cab.

Superstructure

Engine:	Daimler-Benz OM 366 LA water-cooled 6-cylinder Diesel Engine. Output to DIN: 151 kW (205 HP). Fuel-tank capacity: 79 gallons.
Hydraulic system:	Two variable-displacement axial-piston pumps with automatic power control and one fixed-displacement pump (enable the operator to engage three motions at the same time). One fixed-displacement pump for low-pressure servo-control.
Hoist 1:	Variable-displacement axial-piston motor with planetary reduction, spring-loaded multiple-disk brake, hoist rope.
Hoist 2:	Variable-displacement axial-piston motor with planetary reduction, spring-loaded multiple-disk brake, hoist rope.
Slwewing:	Axial-piston hydraulic motor with planetary reduction. Foot-pedal operated service brake and spring-loaded holding brake.
Boom elevation:	Two differential cylinders with pilot-controlled lowering brake valve.
Control:	Electric pilot control by two 4-position self-centering hand levers.
Crane cab:	Spacious all-steel comfortable cab with sliding door, large folding-out windscreen, and armoured glass roof window, controls and instrumentation for all crane movements, working light. Water-type heater, operation self-contained or engine-dependent, with engine preheating and 7-day programmable timer, thermostat controlled. Windshield washer and intermittent control wiper.
Main boom:	Five-section telescopic boom, fabricated from high-grade close-grained structural steel, featuring the familiar DEMAG «ovaloid» design, telescoping with partial load, with diagonal self-centering plastic shoes. Boom head designed to accommodate boom extension, fixed and luffing fly jib.
Counterweight:	211,500 lb, divided.
Safety devices:	Standard: electronic safe load indicator with digital read-out for hook load, rated load, boom length, boom angle, load radius; monitoring devices to assist in trouble shooting; analog display to indicate the capacity utilization; limit switches on hoist and lowering motions, pressure-relief and safety holding valves.

Optional Equipment

Drive/Steering:	14 x 8 x 12, additional drive of axle 7.
Superlift attachment:	The Superlift attachment is a means to increase the lifting capacity of the normal crane. It essentially consists of the boom-suspension mast with guy ropes, which provides for an automatic rope-length adjustment for boom telescoping, and a 57,500 lb Superlift counterweight. The suspension mast is lowered to the main boom when not needed, or for road transport. The Superlift mast is guyed by bars which fold automatically into transport position when lowered.
Fold-away jib:	39 - 62 ft lattice-type folding jib; offsettable at 0° and 20°.
Fixed fly jib:	Non-folding fixed fly jib of 26 - 177 ft length, using components of the luffing fly jib (0° and 20° offset).
Luffing fly jib:	65 - 256 ft length, with luffing mast, guy bars, electrical equipment, and safety devices (the 2nd hoist is required when using the luffing fly jib).
Additional counterweight:	57,500 lb, attachable to standard counterweight, hydraulic assembly and disassembly without an auxiliary crane.
Additional jack leg:	For special duties on 49 ft main boom.
Heavy-lift attachment:	Possibility of additional reeving on boom head for duties up to 506,000 lb. Possibility of additional reeving on boom head for duties up to 880,000 lb.
Rooster sheave:	Sheave folds to side of boom head.
Auxiliary reeving winch	
Aircraft warning light	
Anemometer	

Notes to lifting capacity

Ratings do not exceed 85%/75% of tipping load. 75% ratings are in compliance with DIN 15019.2 (test load=1.25x suspended load + 0.1 x dead weight of boom reduced to boom point).

Weights of hook blocks and slings are part of the load, and are to be deducted from the capacity ratings.

Crane operation with main boom is permissible up to a

wind pressure of 60 N/m²
wind speed of 32 ft/s

Consult operation manual for further details on wind speed.

All capacities above the parting line are based on structural competence. Capacities below the parting line are based on machine stability.

Crane operation is subject to computer charts, only!

For crane operation, consult operation manual first.