

CLARK

1500-C

Specifications

Crawler Crane

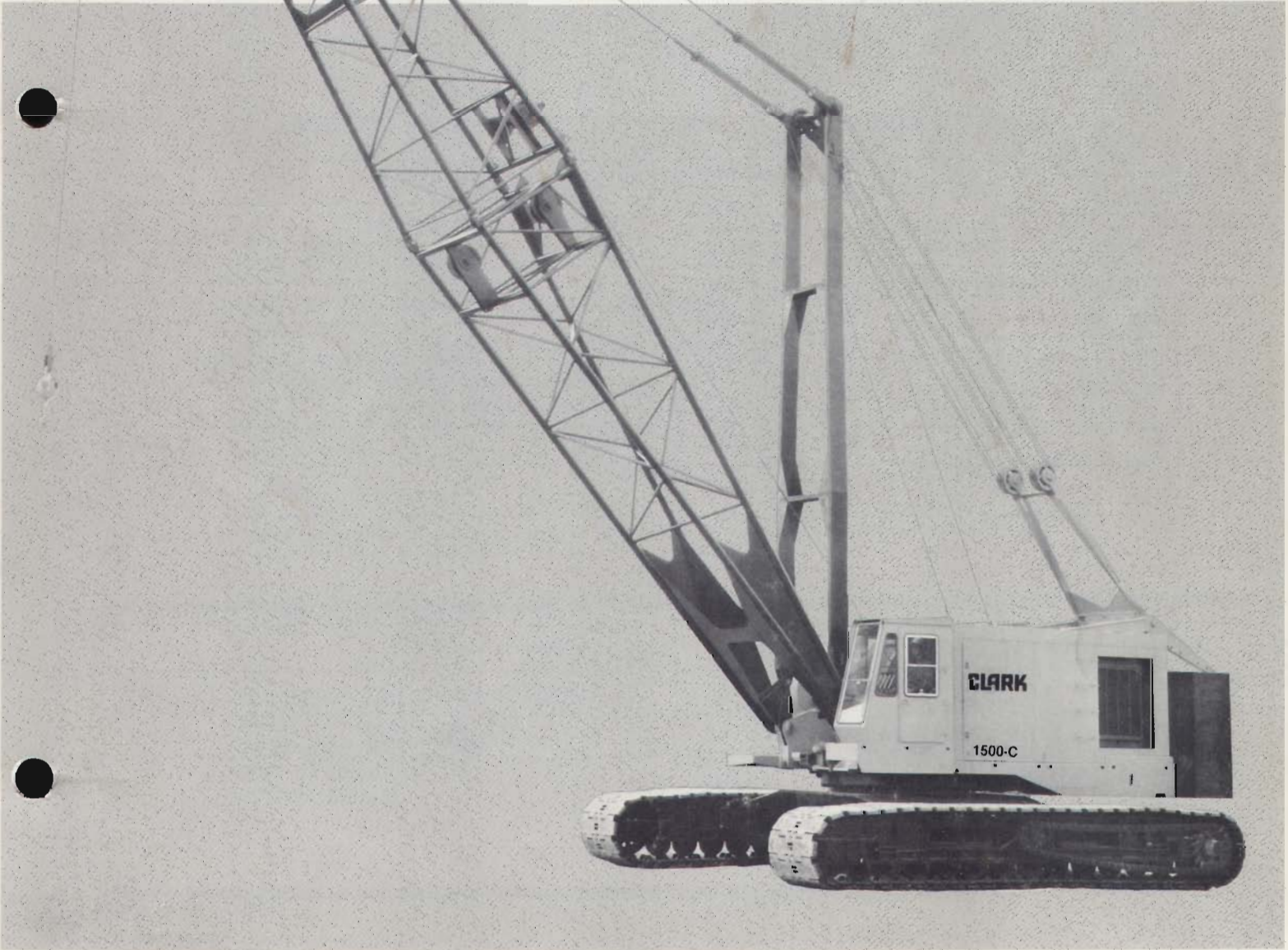

CLEARANCE AND DIMENSIONS

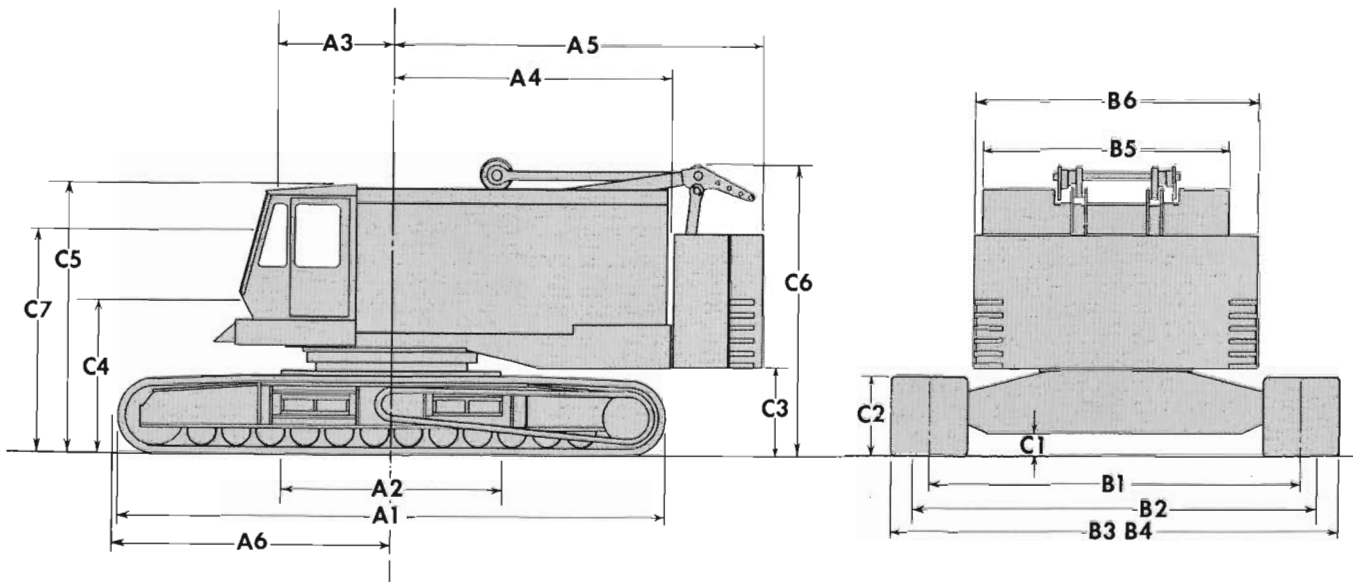

FRONT TO BACK

| | | |
|-----|---------------------------------|---------|
| A1. | Crawler Length | 24'-9½" |
| A2. | Truck Base Length | 10'-2¼" |
| A3. | C Boom Foot to C Rotation | 5'-3½" |
| A4. | Rear End Swing — Rotating Unit | 14'-8½" |
| A5. | Rear End Swing — 57,500# C'w't | 16'-8¾" |
| | Rear End Swing — 100,000# C'w't | 17'-6½" |
| | Rear End Swing — Gantry Lowered | 18'-0¼" |
| A6. | Over Corners — 32" Treads | 15'-10" |
| | Over Corners — 42" Treads | 16'-1" |

SIDE TO SIDE

| | | |
|-----|--|---------|
| B1. | C to C Tread Rollers | 17'-0" |
| B2. | Overall Length of Axles | 18'-5½" |
| B3. | Overall Width Crawlers with 32" Treads | 19'-8" |
| B4. | Overall Width Crawlers with 42" Treads | 20'-6" |
| B5. | Overall Width Cab | 11'-2½" |
| B6. | Overall Width, Rotating Unit and Counterweight | 13'-0" |

VERTICAL

| | | |
|-----|-----------------------------------|---------|
| C1. | Ground Clearance | 10½" |
| C2. | Ground to Top Crawler (Maximum) | 3'-6⅞" |
| C3. | Ground to Bottom of Counterweight | 3'-11" |
| C4. | Ground to C of Boom Foot Pin | 6'-10⅞" |

| | | |
|-----|---------------------------------|----------|
| C5. | Ground to Top of Cab | 12'-1⅝" |
| C6. | Overall Height Backhitch Gantry | 13'-5⅞" |
| C7. | Eye Level Standard Cab | 10'-11⅜" |

CRANE WORKING RANGES

RECOMMENDED REEVING FOR HOOK BLOCK

| Load in Pounds | Parts of Line |
|----------------|---------------|
| To 25,000 | 1 |
| Over 25,000 | 2 |
| Over 50,000 | 3 |
| Over 75,000 | 4 |
| Over 100,000 | 5 |
| Over 125,000 | 6 |
| Over 150,000 | 7 |
| Over 175,000 | 8 |
| Over 200,000 | 9 |
| Over 225,000 | 10 |
| Over 250,000 | 11 |
| Over 275,000 | 12 |

Requires 1" Dia. Wire Rope having a Minimum Breaking Strength of 89,800 lbs.

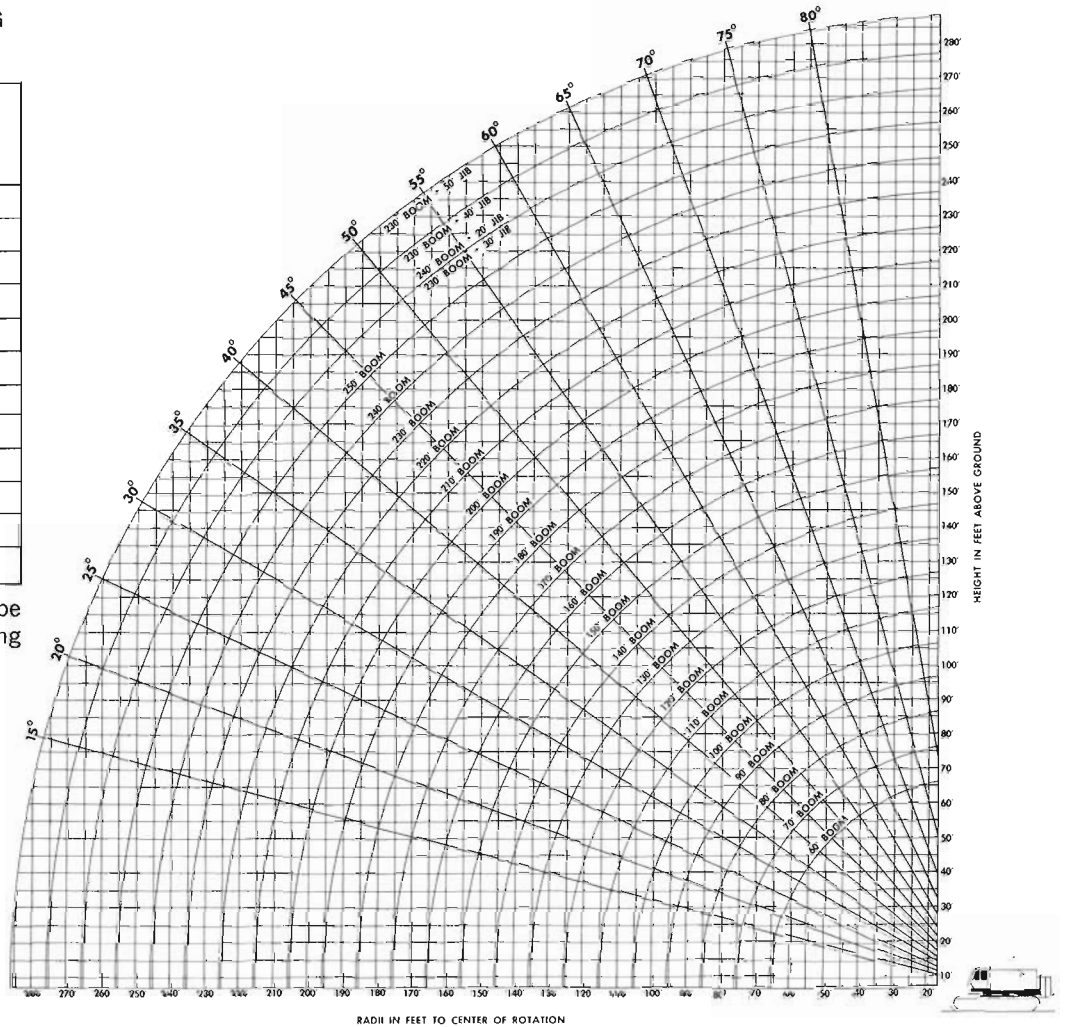
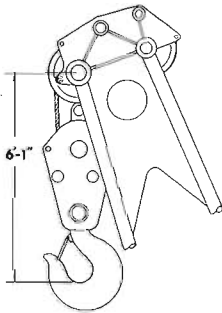

JIB DATA

| LENGTH | RATING | WEIGHT | OFFSET | EFFECTIVE WEIGHT |
|--------|---------|--------|--------|------------------|
| 20' | 18 Tons | 1,885# | 6'-11" | 1,905# |
| 30' | 12 Tons | 2,305# | 12'-9" | 2,800# |
| 40' | 9 Tons | 2,725# | 18'-9" | 3,895# |
| 50' | 7 Tons | 2,995# | 24'-8" | 4,670# |

Jib capacities are approximately the same as boom capacities at any given radius, but not to exceed the rating listed above. Effective jib weight to be subtracted from boom capacity chart if load is raised on boom point when jib is assembled on boom.

MAXIMUM LENGTH BOOM OR BOOM PLUS JIB THAT CAN BE HANDLED HORIZONTALLY



| | OVER SIDE | OVER END WITH WEDGES |
|---------------|------------|----------------------|
| BOOM | 230' | 250' |
| Boom Plus Jib | 220' + 20' | 240' + 20' |
| | 210' + 30' | 230' + 30' |
| | 210' + 40' | 230' + 40' |
| | 210' + 50' | 230' + 50' |

CRANE ATTACHMENT

| | | |
|-----|--|----------|
| A-2 | Includes: 60' pin connected tubular boom (75" x 85") with hammerhead point with six (6) lower main sheaves and two (2) top guide sheaves plus two (2) guide sheaves at base of point section; mast assembly with fourteen (14) part boom hoist reeving and pendants for basic boom; telescopic boomstop with air shutoff; boom angle indicator; 24" L.H. and R.H. smooth laggings (1"); foot accelerator; swing snubber and swing brakes; ropes; 100,000# two piece counterweight. | 120,275# |
|-----|--|----------|

When machine is equipped as a Crane, the following parts included above are installed in the Rotator and can be deducted from the above weight to obtain correct reduction for removing the front.

| | |
|---|----------|
| 1. 24" L.H. Smooth Lagging (1") | 760# |
| 2. 24" R.H. Smooth Lagging (1") | 830# |
| 3. Boom Stop with Air Cutoff | 1,380# |
| 4. Accelerator, Swing Snubber Controls and Wire Ropes | 2,615# |
| 5. Total Rotator Crane Parts—Less Cwt. | 5,585# |
| 6. Counterweight | 100,000# |

BOOM AND SUSPENSION

| | |
|-------------------------------|---------|
| 1. Base Section | 4,870# |
| 2. Point Section with Sheaves | 5,610# |
| 3. Mast | 3,780# |
| 4. Pendants for Basic Boom | 430# |
| Total of Above four (4) items | 14,690# |

OPTIONAL CRANE ACCESSORIES—ADD

| | |
|--|--------|
| 1. Extensions (with pendants)—60' pin connected boom (75" x 85") x Section | |
| A. 10' | 1,460# |
| B. 20' | 2,315# |
| C. 40' | 4,010# |

| | |
|----------------------------------|------|
| 2. Jib — Tubular — pin connected | |
| A. Jib Base | 400# |
| B. Jib Point and Point Shaft | 580# |
| C. 10' Extension with Pendants | 420# |
| D. 20' Extension with Pendants | 690# |
| E. Strut | 600# |
| F. Basic Wire Ropes and Pendants | 305# |



TRUCK BASE: The truck base is of all welded construction with axles designed to bolt to the side frames. The swing gear, and the anti-friction swing circle are integral with the truck base.

SIDE FRAME ASSEMBLY: The side frames are of welded construction using high alloy steel for great strength and durability. The side frames may be easily removed, with treads and drive chain in place, to facilitate machine transport.

VERTICAL PROPEL SHAFT: Transmits propel power from rotating assembly to horizontal propel shaft in truck base. It is mounted in pressure lubricated bronze bushings.

HORIZONTAL PROPEL SHAFT: Three piece shaft transmits power from vertical propel shaft to drive sprockets in side frames. Bevel gears run in sealed oil bath.

STEERING AND TRUCK LOCK: Two large diameter, wide face brakes serve as crawler locks and safety propel brakes. Brakes are spring-set and air-released and each is at all times connected to its respective crawler. Air operated gear type

jaw clutches engage for propelling. Air engages jaw clutches and releases brakes simultaneously. Either clutch can be disengaged, setting brake for steering. Any accidental loss of air automatically sets brakes to lock crawlers.

INDEPENDENT PROPEL: Additional air operated clutches and shafting provided for simultaneous, independent hoist, swing, and propel functions.

ANTI-FRICTION BEARING SWING CIRCLE: Large anti-friction, single row, sealed bearing. It is welded to the truck base and bolts to the rotating base.

TREAD ROLLERS: Hardened rims, with sealed, bronze bushing type bearings.

CRAWLER TREADS: 32" and 42" wide treads available. They are made of heat-treated alloy steel to provide superior wearing quality. Hardened steel pins are used to connect treads. Tread belts are driven by heavy duty roller chains (one per side): The chains are integral with side frame assemblies.

ROTATING BASE: Welded fabrication with integral machinery frames, depressed center section for horizontal gear train, and a built-in fuel tank having a 256 gallon capacity.

POWER PLANT: See Power Plant Data Table.

SHAFTING: All shafting is of high strength, heat treated, alloy steel. Involute splines are used extensively.

BEARINGS: All horizontal operating machinery on the rotating assembly is mounted on anti-friction bearings. The single exception is the boom hoist drum shaft which is mounted on bronze journal bearings.

HOIST DRUM SHAFT: Shaft is supported by self-aligning roller bearings. Cable drums, clutch and brake housings are mounted on antifriction bearings. Cable laggings, of various sizes, are demountable.

BOOM HOIST CLUTCH SHAFT: Driven by heavy duty roller chain from reversing clutch shaft, and equipped with spring set air released holding brake. A ratchet and pawl are provided to give positive holding and added safety. Power boom lowering is accomplished through the planetary reduction unit on this shaft which provides a smooth, positive, precision, controlled operation.

BOOM HOIST DRUM SHAFT: Two boom hoist drums are mounted on this shaft which is gear driven from the boom hoist clutch shaft.

REVERSING CLUTCH SHAFT UNIT: Sub-assemblies of horizontal and vertical shafts in an oil tight case. Driven by power take-off chain.

VERTICAL SWING SHAFT: Mounted between the vertical propel and vertical reversing shaft, mounted on pressure lubricated bronze bushings. Integral spur pinion at lower end of shaft engages internal teeth of the ring gear.

CONTROLS: All controls are compressed air and mounted in the operator's cab.

HOIST BRAKES: External contracting, friction band type; air-set by treadle valves. Spring-set safety feature locks brakes when air pressure is shut off by valves in operator's cab.

POSITIVE SWING LOCK: This mechanism is air-released and spring-set; it engages gear teeth in the ring gear.

SWING SNUBBER: Air operated band on left hand clutch of horizontal reversing clutch shaft provides a smooth, sensitive snubbing action.

LIGHTING EQUIPMENT: 2 KW generator and corresponding wiring available in either A.C. or D.C.

ROTATING ASSEMBLY GROUP

BACK HITCH GANTRY: Pinned to rear of rotating unit and has a low profile for traveling. Gantry must always be in lowest position, with upper 3" diameter gantry pins in place, when handling a boom or boom and load. Refer to operator's manual for counterweight handling attachment operating instructions.

CAB: All steel construction and equipped with environmental operator's cab lined with sound barrier and deadening material which cuts noise level by an estimated 50 percent. Cab can be heated or air-conditioned. Controls are grouped for maximum operator convenience, comfort, and efficiency. Side and front windows slide up and down for ventilation. Numerous hatches and doors are provided for access to machinery and power plant. Hoist drums are not covered.

BOOM SUSPENSION: A 14-part boom hoist wire rope suspension is used with all lengths of boom. See mid-point suspension data. Booms 140' long and less may be handled horizontally, without live load, with the mast pinned to the boom base, to provide a low travel height. With longer booms, normal pendant suspension must be used.

BOOM STOP: Telescopic type with automatic air shut-off of boom hoist.

POWER LOAD LOWERING: Chain driven and geared to the main hoist drum it provides a smooth, precision lowering operation.

THIRD DRUM: One piece lagging mounted independently on front of machine. Chain driven and operated by air controlled clutch and brake.

COUNTERWEIGHT: Two (2) piece cast iron counterweight totaling 100,000 lbs. suspended on brackets and positively held at rear of rotating unit.

COUNTERWEIGHT HANDLING DEVICE: Capable of installing or removing the counterweights and actuated by two (2) hydraulic cylinders mounted in the rear gantry legs.

LUBRICATION: Horizontal gear train, boom hoist chain, bevel swing gears, truck gears and power take-off chain operate in oil filled cases. In the case of gear train and bevel swing gears, the oil is circulated and applied to the gears by a rotary type oil pump; the bottom of the truck gear case and rotating base is provided with both a test and drain plug. Propel chains, and control mechanism are hand lubricated; all other points including crawler adjusting screws are pressure lubricated by hand guns.

CLUTCH AND BRAKE DATA

| Function | CLUTCHES | | | | BRAKES | | | |
|---------------------|----------|--------|----------|---------------------|--------|--------|----------|---------------------|
| | Type | Width | Diameter | Area | Type | Width | Diameter | Area |
| Hoist | Band | 5 1/2" | 40" | 587 In ² | Band | 6" | 46" | 713 In ² |
| Swing | 2 Shoe | 5 1/2" | 32" | 424 In ² | Band | 3 1/2" | 33 1/2" | 299 In ² |
| Power Load Lowering | Band | 4 1/2" | 24" | 294 In ² | | | | |
| Boom Hoist | Band | 5 1/2" | 30" | 445 In ² | Band | 4" | 32" | 302 in ² |
| Steering Brakes | | | | | Band | 5" | 27" | 424 In ² |
| Independent Propel | Band | 5 1/2" | 32" | 488 In ² | | | | |
| Intermediate Propel | Band | 5 1/2" | 32" | 488 In ² | | | | |
| Third Drum | Band | 6" | 23" | 383 In ² | Band | 3 1/2" | 24 3/4" | 253 In ² |

BOOM DATA

| | |
|------------------------|------------|
| Boom Description | Tubular |
| Type Service | Crane |
| Type Boom Point | Hammerhead |
| Quantity Point Sheaves | 6 |
| Diameter Point Sheaves | 19" P.D. |
| Basic Boom Length | 60' |

| | |
|-----------------------------|----------------|
| Type Connections | Pin |
| Maximum Length | 250' |
| Extensions | 10', 20' & 40' |
| Cross Section | 75" x 85" |
| Type Chords | Tubular |
| Chord Material P.S.I. Yield | 100,000 PSI |

| | | |
|--|----------|----------|
| Time required to raise or lower a 60' basic boom from 20° above horizontal to 70° above horizontal — with planetary boom hoist and 14 part boom hoist reeving. | To Raise | To Lower |
| | 59 Sec. | 118 Sec. |

NOTE: Times above vary slightly with different boom lengths.

| |
|---|
| MIDPOINT SUSPENSION |
| Required On Booms 200' through 250' Long |

POWER PLANT DATA

| Make | Model | Fuel | Cyl. | Bore and Stroke | Gross Rated H.P. | Mech. Drive H.P. @ Governed R.P.M. | Torque Conv. H.P. @ Governed R.P.M. |
|---------------|--------------|--------|------|-----------------|------------------|------------------------------------|-------------------------------------|
| Cumm. w/T. C. | NT-855-P-335 | Diesel | 6 | 5 1/2" x 6" | 335 @ 2300 | — | 300 @ 2100 |

Fuel Tank Capacity — 256 Gallons

WORKING WEIGHTS

(APPROXIMATE IN POUNDS)

| | |
|---|--------------|
| Weight based upon a machine equipped with a Cummins power plant and torque converter, 25' truck with 42" treads, 100,000 lbs. of counterweight, and a 60' basic boom. | |
| Crane | 278,635 Lbs. |

PERFORMANCE DATA

| | |
|--------------------------|-------------|
| Swing Speed | 3.2 R.P.M. |
| Gradability | 30% |
| Travel Speed: | |
| Standard Propel | 1.02 M.P.H. |
| Independent Propel | 1.31 M.P.H. |

In accordance with our established policy of constantly improving our products, we reserve the right to change or modify our products or our product specifications at any time without notice.

CLARK

Lima Division

LIMA, OHIO 45802

Manufactured and Sold in Conformance with U.S. Department of Commerce Commercial Standard CS90-58.

DISTRIBUTED BY