

PK 40002 EH

High Performance

PALFINGER CRANE

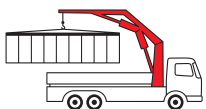

KTL
protected

**Paltronic
50**
controlled

RRC
Radio Remote Control
operated

ISC
Integrated Stability Control
monitored

AOS
Active Oscillation Suppression
inside

DPS
Dual Power System
activated

It's a snap to join the heavy-duty range

Comfort cable routing and tiltable cable winch

Equipped with the endless slewing system and double slewing drive, maintenance-free extension boom system, functional design elements and Power Link Plus, the PK 40002 EH is truly an ambassador of PALFINGER's leadership in technology.

As the perfect crane for a 3-axle chassis, it has a wide spectrum of uses and is equally suited for assembly work, transport of containers, rescue operations, and other heavy-duty jobs.



New contemporary design



Dual Power System Plus facilitates maximum lifting power



Power Link Plus

This knuckle boom, specially developed by PALFINGER which can be angled upwards stands out by virtue of excellent movement geometry. Even in the tightest spaces difficult crane jobs can be performed with precision.



Maintenance-free extension system

With the maintenance-free extension system PALFINGER sets a clear path in easy servicing. The use of sliding elements made of special plastic in combination with the proven KTL cathodic dip painting means that the extension boom system no longer has to be serviced by the operator. This not only saves time and expense but also protects the environment.



Operator Panel for Stabilizer Control

All important information about the crane is visible on the operator panel. The operating hours are counted and displayed via a digital display. The box level is visible from all sides. The control valves for crane and auxiliary stabilizers are mounted on the base frame as standard.



Cable winch and Comfort Cable Routing

The 2.5 t or 3.5 t cable winch on the main boom for use in combination with the fly-jib is available as a hydraulically tilted version and can be operated comfortably via the radio remote control. The lower overall height due to tilting is beneficial for crane applications inside buildings and during transport when the crane boom is not folded down. The cable on the winch is also guided laterally as standard and as a result no longer needs to be detached on folding down the crane.



Endless slewing mechanism

The endless slewing mechanism with slewing ring, permits an unrestricted radius of operation and produces a high slewing torque. As a result crane operations are faster and more efficient. Two slewing drives are standard for cranes with more than four hydraulic extensions!

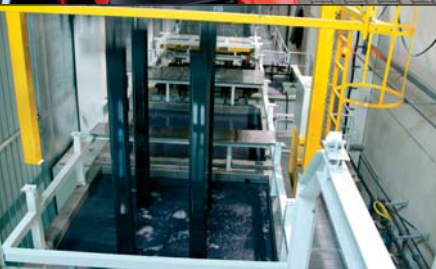

KTL – the cathodic dip painting

The shot-blasted crane parts are covered in zinc phosphate in an immersion process and coated electro-statically. The subsequent two-component top coating of paint provides a surface protection which in the past was usually only found in the automotive industry.



AOS (optional)

The Active Oscillation Suppression system available exclusively from PALFINGER compensates for jolts and sharp stress cycles caused by crane operation. Because oscillations are eradicated the crane can work with precision, much faster and therefore more cost-efficiently.

Endless slewing system and double slewing drive

ISC (optional)*

The integrated stability control (ISC) is a system that monitors the stability of the crane vehicle. The system adjusts the crane's lifting forces depending on the current stability support situation and the crane boom to ensure the vehicle's stability over the entire working area.

* ISC or an alternative system for monitoring stability is mandatory in the version compliant with EN12999:2009.

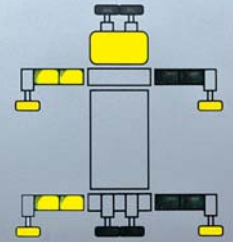

Return oil utilisation

The high speed of the extension system is impressive. It results from return oil utilisation, which is installed as standard, and the generously dimensioned hydraulic lines. This increases efficiency in all types of applications!



Outriggers and stabilizers that can be tilted upwards

The standard 7.4 m (24' 3") outriggers ensure good stability. All the outriggers are fitted as standard with a ball-jointed support plate that can be swivelled through 10°. This enables them to adapt optimally to the ground. The enlarged plate also reduces the pressure on the ground. The crane's stabilizer cylinders can be tilted fully hydraulically upwards through 180° (optional equipment) and are fitted with LED warning lights.



Hose equipment for auxiliary equipment

Hoses providing oil supply for auxiliary equipment are routed in compact trays and protective chains. A clean design offering maximum service life.



Advanced Package

- E-HPLS
- Paltronic 50
- Radio remote control with LED display
- Danfoss control valve PVG2000



Internally routed hose guide on the main boom

The hydraulic hoses between the main and outer booms are internally routed. This invention, which is to be patented, provides protection against dirt and damage.



Functional Design

Synthetic covers protect sensitive crane components against dirt and impact. That reduces service and maintenance time and greatly extends the life of your loading crane. Integrating the oil tank on the base helps to save space. Additional room for installation on the chassis is no longer necessary.



A crane generation under the banner of technology and functional design

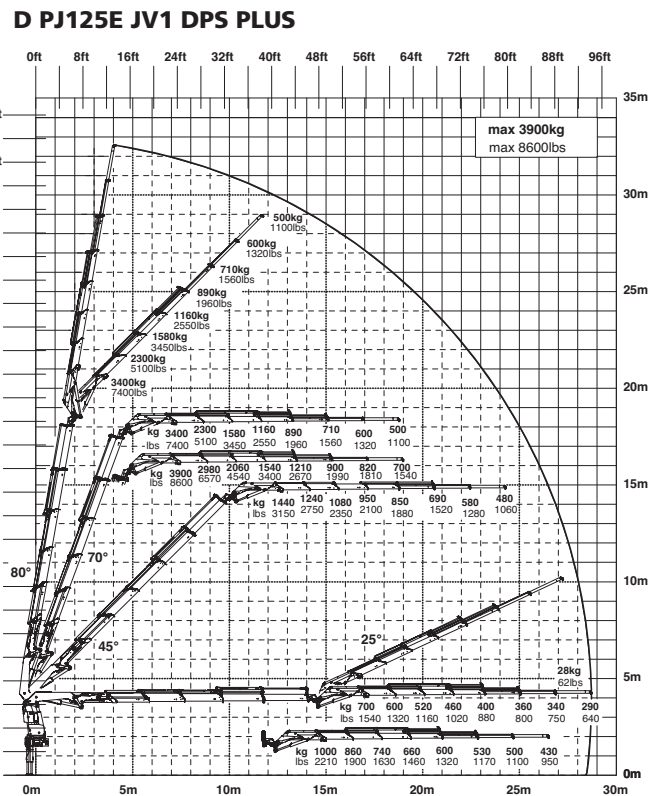
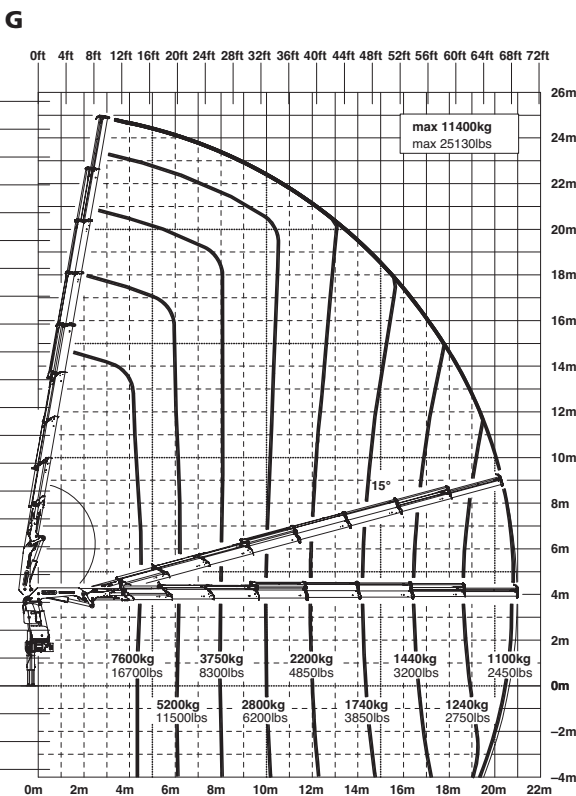
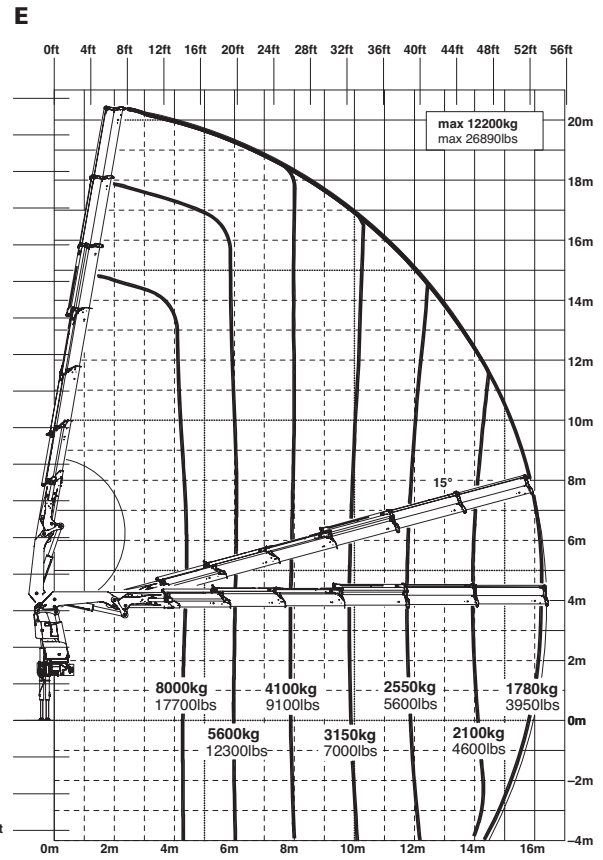
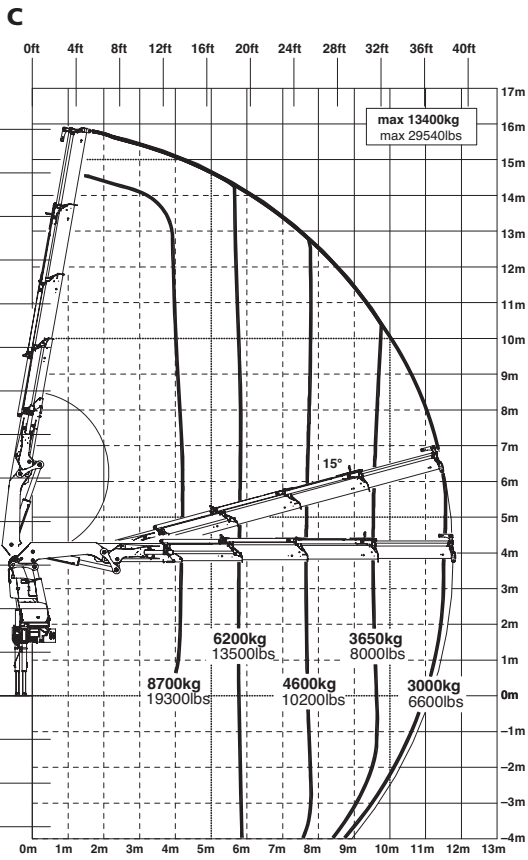

Perfect for huge outreaches

A

Lifting capacities

max.	14300 kg	31500 lbs	
4.1 m	13' 5"	9300 kg	20500 lbs
5.8 m	19' 0"	6700 kg	14700 lbs
7.6 m	24' 11"	5100 kg	11200 lbs

B

Lifting capacities

max.	13900 kg	30640 lbs	
4.1 m	13' 5"	9100 kg	20000 lbs
5.8 m	19' 0"	6400 kg	14100 lbs
7.6 m	24' 11"	4850 kg	10700 lbs
9.5 m	31' 2"	3900 kg	8600 lbs

C

Lifting capacities

max.	13400 kg	29540 lbs	
4.2 m	13' 9"	8700 kg	19300 lbs
5.8 m	19' 0"	6200 kg	13500 lbs
7.6 m	24' 11"	4600 kg	10200 lbs
9.6 m	31' 6"	3650 kg	8000 lbs
11.6 m	38' 1"	3000 kg	6600 lbs

D

Lifting capacities

max.	12700 kg	27990 lbs	
4.3 m	14' 1"	8400 kg	18400 lbs
6.0 m	19' 8"	5900 kg	12900 lbs
7.8 m	25' 7"	4350 kg	9600 lbs
9.7 m	31' 10"	3400 kg	7500 lbs
11.7 m	38' 5"	2750 kg	6100 lbs
13.9 m	45' 7"	2300 kg	5100 lbs

E

Lifting capacities

max.	12200 kg	26890 lbs	
4.4 m	14' 5"	8000 kg	17700 lbs
6.1 m	20' 0"	5600 kg	12300 lbs
7.9 m	25' 11"	4100 kg	9100 lbs
9.8 m	32' 2"	3150 kg	7000 lbs
11.8 m	38' 9"	2550 kg	5600 lbs
14.0 m	45' 11"	2100 kg	4600 lbs
16.3 m	53' 6"	1780 kg	3950 lbs

F

Lifting capacities

max.	11700 kg	25790 lbs	
4.5 m	14' 9"	7700 kg	17000 lbs
6.2 m	20' 4"	5400 kg	11800 lbs
8.0 m	26' 3"	3900 kg	8600 lbs
9.9 m	32' 6"	3000 kg	6600 lbs
11.9 m	39' 1"	2350 kg	5200 lbs
14.1 m	46' 3"	1900 kg	4200 lbs
16.4 m	53' 10"	1600 kg	3550 lbs
18.6 m	61' 0"	1400 kg	3100 lbs

G

Lifting capacities

max.	11400 kg	25130 lbs	
4.5 m	14' 9"	7600 kg	16700 lbs
6.2 m	20' 4"	5200 kg	11500 lbs
8.0 m	26' 3"	3750 kg	8300 lbs
9.9 m	32' 6"	2800 kg	6200 lbs
12.0 m	39' 4"	2200 kg	4850 lbs
14.2 m	46' 7"	1740 kg	3850 lbs
16.4 m	53' 10"	1440 kg	3200 lbs
18.6 m	61' 0"	1240 kg	2750 lbs
20.8 m	68' 3"	1100 kg	2450 lbs
23.0 m*	75' 6"	900 kg	1980 lbs
25.0 m*	82' 0"	600 kg	1320 lbs

E PJ080C JV2 DPS PLUS

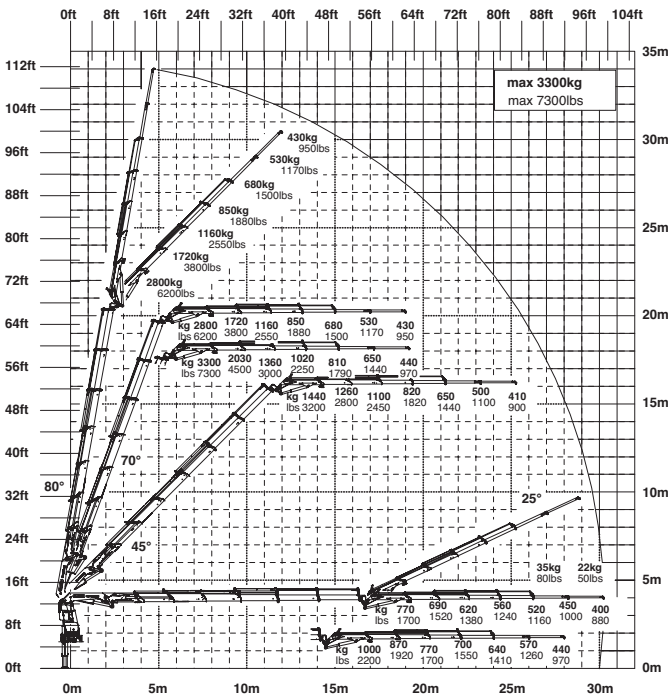

F PJ060B JV2 DPS PLUS

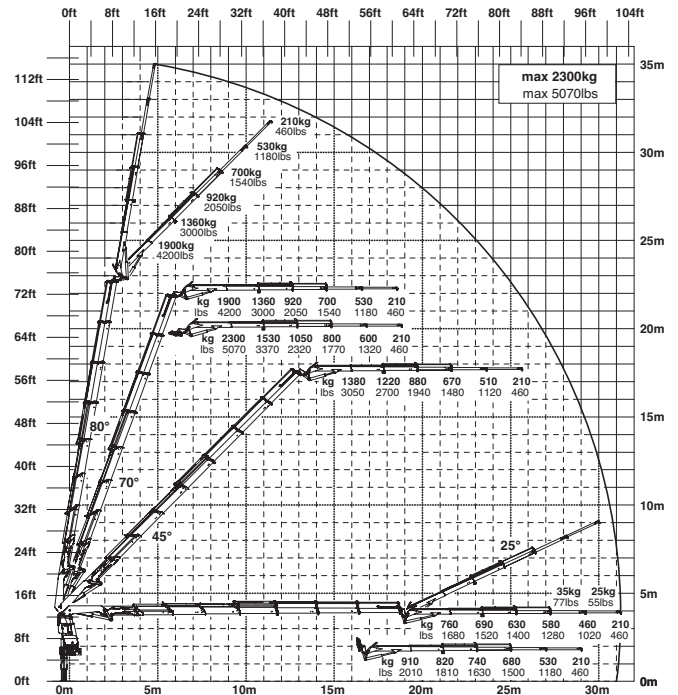

The outreaches stated are with a boom angle of 20° and are therefore not the maximum.

* mechanical extension

Offers numerous
comfort and safety
functions

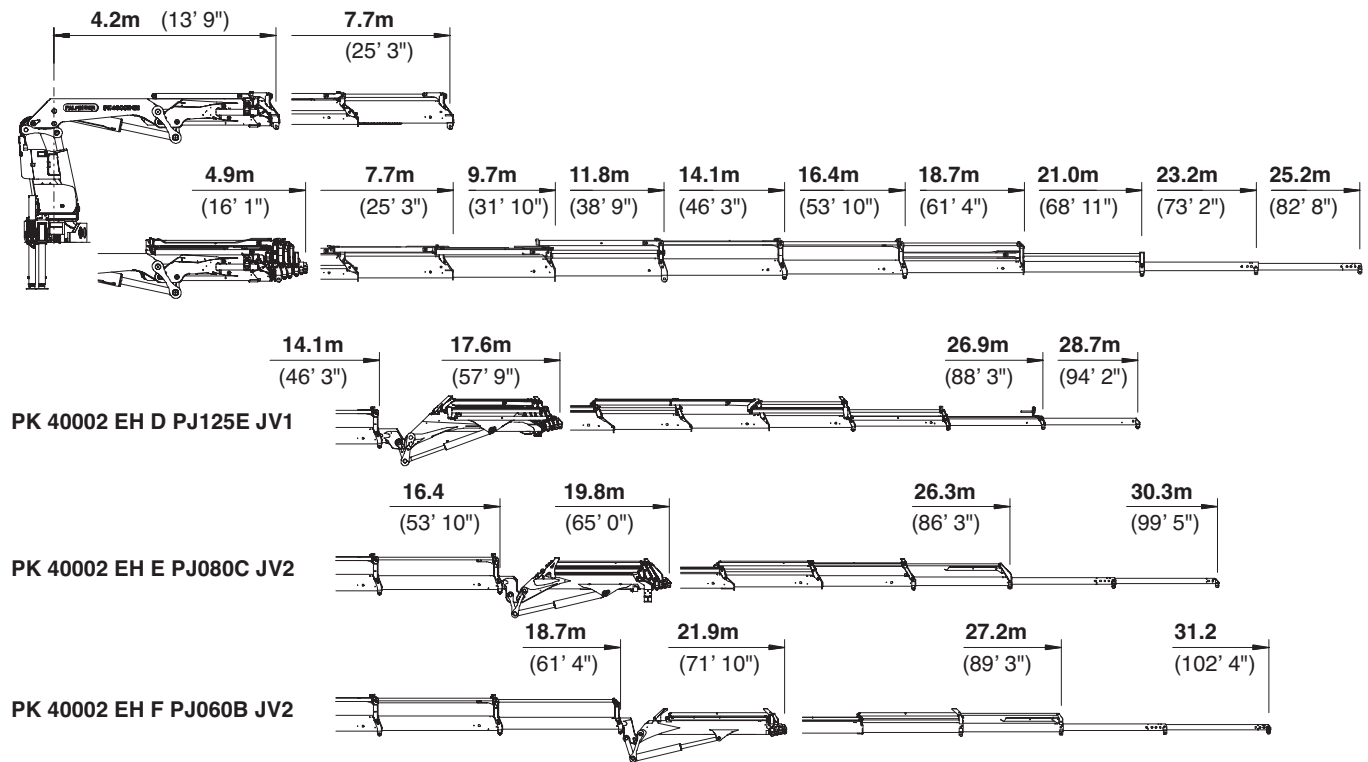

Technical Specifications (EN 12999 HC1 HD4/B3)

Max. lifting moment	39.3 mt/385.5 kNm	284330 ft.lbs
Max. lifting capacity	14600 kg/143.2 kN	32190 lbs
Max. hydraulic outreach	21.0 m	68' 11"
Max. manual outreach	25.2 m	82' 8"
Max. outreach (with fly jib)	31.2 m	102' 4"
Slewing angle	endless	
Slewing torque		
with 1 gear	3.8 mt/37.3 kNm	27510 ft.lbs
with 2 gears	5.0 mt/49.1 kNm	36210 ft.lbs

Stabilizer spread	7.4 m	24' 3"
Fitting space required (std.)	min. 1.33 m/4' 4" max. 1.47 m/4' 10"	
Width folded	2.51 m	8' 3"
Max. operating pressure	350 bar	5075 psi
Recommended pump capacity	from 80 l/min 21.1 US gal./min to 100 l/min 26.4 US gal./min	
Dead weight (std.)	3851 kg	8490 lbs

