

SPECIFICATION

OF

KATO FULLY HYDRAULIC TRUCK CRANE

MODEL NK - 550VR

CARRIER : NISSAN DIESEL KG48U

KATO WORKS CO . , LTD .  
Tokyo , Japan

STD:LH

KATO FULLY HYDRAULIC TRUCK CRANE

MODEL NK-550VR

FOREWORD:

As the production and development of construction machinery has increased, so has the demand for the KATO NK-550VR. This model has established great popularity and renown reputation for its simplified handling, all hydraulic system, reliable service and wide range of application.

These achievements are due solely to the vast technical knowledge of KATO engineers and the foresighted planning of KATO ideas presented to us by our customers, for we have, at all times, fostered good customer relationships.

This KATO NK-550VR is mounted on a truck-carrier, and it develops a maximum pay load of 55 metric tons whilst maintaining minimum weight and dimensions. This enhances the maneuverability of the KATO NK-550VR and enables the machine to be rapidly transported from site to site.

Rapid, rugged and reliable. These are the key words to describe the KATO NK-550VR for this machine is able to perform lifting, lowering, slewing and outrigger operations by a fast and reliable hydraulic system, providing the best service during handling operations.

SPECIFICATION OF NK-550VR

## 1. Crane Specification

Maximum rated lifting capacity	: 55 metric tons × 3.0 m
Boom length	: 11.0 m    43.0 m ( 5 section )
Fly jib length	: 9.2 m    15.0 m ( 2 section )
Boom derricking angle	: -2.5°    81°
* Boom derricking time	: 62 sec. (-2.5°    81° )
* Boom extending time	: 149 sec. (11.0m    43.0m)
* Hoisting line speed	
Main winch	: 117 m/min. (at 3rd layer)
Auxiliary winch	: 108 m/min. (at 2nd layer)
* Hoisting hook speed	
Main winch	
( part of line; 14 )	: 8.35 m/min. (at 3rd layer)
Auxiliary winch	
( part of line; 1 )	: 108 m/min. (at 2nd layer)
* Slewing speed	: 2.0 min <sup>-1</sup>

## Wire rope for hoisting

## Main winch;

Type	: SeS(48)+6 × WS(31)
Diameter	: 18 mm
Length	: 235 m

## Auxiliary winch;

Type	: IWRC6 × WS(31)
Diameter	: 18 mm
Length	: 125 m

Hydraulic system	
Oil pump	: 4 section gear type
Hoisting motor	: Axial plunger type
Slewing motor	: Axial plunger type
Cylinder	: Double acting type
Control valve	: 3 position 4 way double acting with integral check and relief valves
Oil reservoir capacity	: 695 L
Winch system	
Main winch	: Driven by axial plunger type
Auxiliary winch	: hoisting motor through planetary gear reduction. Controlled independently by respective operating lever. Equipped with automatic brake. <u>With FREE FALL DEVICE</u>
Crane cab	: All steel welded construction
Safety devices	: ACS (Automatic crane stopper) Boom falling prevention device Winch hoisting limiter Winch drum lock device Winch drum turning indicator Automatic winch brake Irregular winding prevention device Hydraulic safety valve Outrigger lock device
* Speed	: Subject to no load

## 2. Carrier Specification

Maximum traveling speed : 83 km/h  
 Grade ability ( tan ) : 53 % (computed, @G.V.W.= 39700kg)  
 Minimum turning radius  
 (center of extreme outer tire) : 10.8 m

## General dimensions

Overall length : approx. 13370 mm  
 Overall width : approx. 2820 mm  
 Overall height : approx. 3650 mm  
 Wheel base : 1470 mm + 3930 mm + 1400 mm = 6800 mm  
 Treads; Front : 2250 mm  
 Rear : 2110 mm  
 Center to center of  
 extended outriggers : 7000 mm (Fully extended)  
 4800 mm (Intermediately extended)  
 2500 mm (Fully retracted  
 blocked on vertical cyls.)

Gross vehicle weight : approx. 39700 kg  
 Front weight : approx. 15800 kg  
 Rear weight : approx. 23900 kg

## Carrier

Maker : NISSAN DIESEL  
 Model : KG48U  
 Drive system : 8 × 4

## Engine

Maker : NISSAN DIESEL  
 Model : PF6TB (EURO- )  
 Type : 4 cycle, turbo charged, direct injection  
 water cooled, diesel  
 No. of cylinder : 6 inline  
 Piston displacement : 12.503 L

Max. output horsepower		: 257 kW/ 2100 min <sup>-1</sup> (350 PS/ 2100 min <sup>-1</sup> )
Max. output torque		: 1460 N·m/ 1200 min <sup>-1</sup> (148 kg·m/ 1200 min <sup>-1</sup> )
Clutch		: Single dry plate, hydraulic control with air booster
Transmission		: 7 forward & 1 reverse speed
Axles;	Front	: Reverse "ELLIOT" type
	Rear	: Full floating type
Steering		: Ball nut type with power booster
Suspension;	Front	: Semi-elliptic leaf springs
	Rear	: Equalizer beams and torque rods
Brake;	Service	: 2 circuit air brake, 8 wheels internal expanding type
	Parking	: Spring loaded brake
	Auxiliary	: Exhaust brake
Electric system		: 24 V
Battery		: 12 V - 115F51 × 2
Fuel tank capacity		: 300 L
Driver's cab		: Steel, two man, semi under floor type, one side cab
Tire size;	Front	: 315/80R22.5 156/150k
	Rear (dual tire)	: 315/80R22.5 156/150k

WORKING RANGE

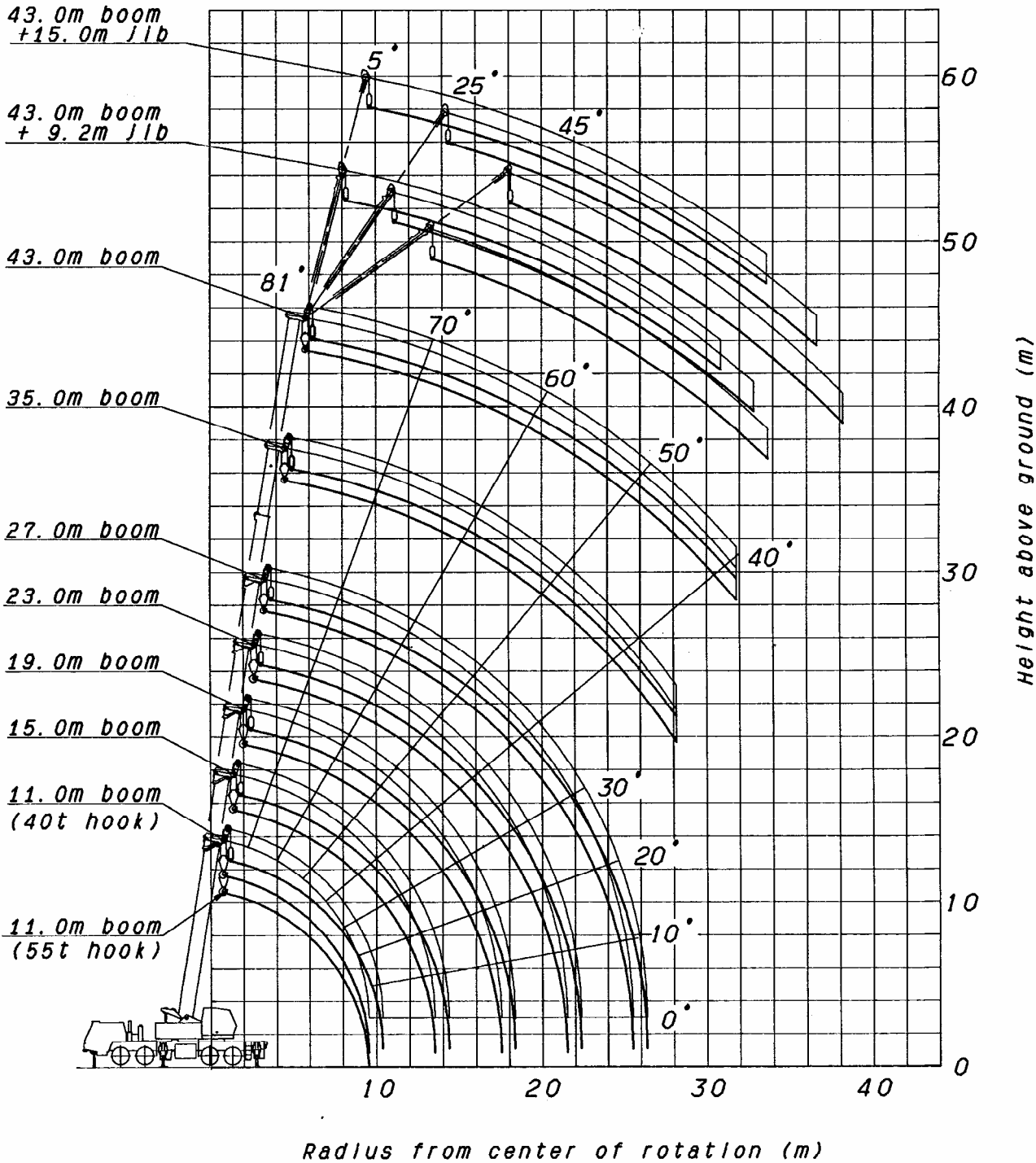

Note: Deflection of boom and jib excluded.

## RATED LIFTING CAPACITY

Based on ISO 4305

Note : Front jack is optional.

Outriggers fully extended with front jack - 360° full range									
Outriggers fully extended without front jack - over side and over rear									
Working radius(m)	11.0m Boom	11.0m Boom	15.0m Boom	19.0m Boom	23.0m Boom	27.0m Boom	35.0m Boom	43.0m Boom	
3.0	55.00	40.00	28.00	28.00	24.00				
3.5	43.70	40.00	28.00	28.00	24.00				
4.0	38.50	38.50	28.00	28.00	24.00	20.00			
4.5	34.20	34.20	28.00	28.00	24.00	20.00			
5.0	30.80	30.80	28.00	28.00	24.00	20.00	14.00		
5.5	27.80	27.80	27.40	27.20	24.00	20.00	14.00		
6.0	25.40	25.40	25.00	24.80	24.00	20.00	14.00		
6.5	23.20	23.20	22.80	22.60	22.50	20.00	14.00	8.00	
7.0	21.40	21.40	21.00	20.80	20.60	19.60	14.00	8.00	
7.5	19.70	19.70	19.30	19.10	19.00	18.00	14.00	8.00	
8.0	17.90	17.90	17.75	17.50	17.30	17.25	14.00	8.00	
8.5	16.20	16.20	15.90	15.70	15.50	15.45	13.80	8.00	
9.0	14.60	14.60	14.40	14.15	14.00	13.90	13.60	8.00	
10.0			11.90	11.65	11.50	11.45	12.30	8.00	
11.0			10.00	9.75	9.60	9.50	10.40	7.80	
12.0			8.40	8.15	8.10	8.00	8.85	7.10	
13.0			7.15	6.90	6.80	6.75	7.55	6.65	
14.0				5.90	5.80	5.75	6.50	6.15	
16.0				4.30	4.20	4.10	4.95	5.35	
18.0					3.00	2.95	3.75	4.20	
20.0					2.10	2.05	2.80	3.30	
22.0						1.30	2.10	2.55	
24.0						0.75	1.50	2.00	
26.0							1.05	1.50	
28.0							0.65	1.05	
30.0								0.70	
31.0								0.50	
Standard hook	for 40 ton + sub hook sheave	for 40 ton				for 20 ton			
Hook mass	450 + 150 kg	450 kg				320 kg			
Parts of line	14	10	8	8	6	5	4	4	
Critical boom angle	-	-	-	-	-	-	33 °	40 °	

(Unit : Metric ton)



Based on ISO 4305

Outriggers intermediately extended without front jack - 360° full range							
Outriggers fully extended without front jack - over front							
Working radius(m)	11.0m Boom	15.0m Boom	19.0m Boom	23.0m Boom	27.0m Boom	35.0m Boom	43.0m Boom
3.0	32.00	28.00	28.00	24.00			
3.5	32.00	28.00	28.00	24.00			
4.0	32.00	28.00	28.00	24.00	20.00		
4.5	29.00	28.00	28.00	24.00	20.00		
5.0	22.00	21.90	21.50	21.40	20.00	14.00	
5.5	17.30	17.20	16.90	16.80	16.70	14.00	
6.0	14.10	14.00	13.70	13.60	13.50	14.00	8.00
6.5	11.80	11.65	11.35	11.30	11.20	12.30	8.00
7.0	10.00	9.85	9.55	9.50	9.45	10.45	8.00
7.5	8.55	8.40	8.15	8.10	8.05	9.00	8.00
8.0	7.40	7.25	7.00	6.95	6.90	7.85	8.00
9.0	5.70	5.55	5.30	5.25	5.20	6.05	6.50
10.0		4.25	4.00	3.90	3.85	4.75	5.20
11.0		3.20	2.95	2.90	2.80	3.70	4.20
12.0		2.40	2.20	2.10	2.05	2.90	3.40
13.0		1.80	1.55	1.45	1.40	2.25	2.70
14.0						1.70	2.15
15.0							1.70
Standard hook	for 40 ton				for 20 ton		
Hook mass	450 kg				320 kg		
Parts of line	8	8	8	6	5	4	4
Critical boom angle	-	-	35 °	48 °	58 °	64 °	68 °

(Unit : Metric ton)

Based on ISO 4305

Outriggers fully retracted (blocked on vertical cyls.) - 360° full range	
Working radius(m)	11.0m Boom
3.0	8.00
3.5	6.40
4.0	5.10
4.5	4.20
5.0	3.40
5.5	2.80
6.0	2.30
6.5	1.90
7.0	1.60
7.5	1.25
8.0	1.00
Standard hook	for 40 ton
Hook mass	450 kg
Parts of line	10

(Unit : Metric ton)

Based on ISO 4305

Outriggers fully extended with front jack - 360° full range Outriggers fully extended without front jack - over side and over rear						
Boom angle (°)	43m Boom + 9.2m Jib					
	Offset 5°		Offset 25°		Offset 45°	
	Working radius(m)	Load (t)	Working radius(m)	Load (t)	Working radius(m)	Load (t)
81.0	10.00	3.50	12.75	2.30	14.60	1.25
80.0	11.05	3.50	13.70	2.30	15.45	1.25
79.0	12.05	3.48	14.65	2.30	16.30	1.24
78.0	13.00	3.40	15.60	2.25	17.20	1.23
77.0	13.90	3.23	16.50	2.19	18.05	1.21
76.0	14.85	3.04	17.40	2.12	18.90	1.19
75.0	15.75	2.90	18.25	2.06	19.75	1.17
74.0	16.70	2.75	19.15	1.99	20.55	1.16
72.0	18.50	2.49	20.90	1.85	22.25	1.12
70.0	20.15	2.28	22.60	1.73	23.90	1.09
68.0	21.85	2.09	24.20	1.62	25.40	1.06
66.0	23.55	1.91	25.80	1.53	26.85	1.04
64.0	25.05	1.68	27.40	1.43	28.35	1.02
62.0	26.55	1.41	28.85	1.24	29.85	1.00
60.0	28.00	1.13	30.20	1.00	31.15	0.85
59.0	28.75	1.00	30.85	0.89	31.80	0.77
58.0	29.45	0.86	31.50	0.77	32.45	0.69
57.0	30.20	0.73	32.20	0.66	33.05	0.61
56.0	30.85	0.63	32.85	0.56	33.70	0.53
Standard hook	for 4 ton					
Hook mass	120 kg					
Parts of line	1					
Critical boom angle	55 °					

(Unit : Metric ton)

Based on ISO 4305

Outriggers fully extended with front jack - 360° full range						
Outriggers fully extended without front jack - over side and over rear						
Boom angle (°)	43m Boom + 15m Jib					
	Offset 5°		Offset 25°		Offset 45°	
	Working radius(m)	Load (t)	Working radius(m)	Load (t)	Working radius(m)	Load (t)
81.0	11.75	2.50	16.20	1.20	19.40	0.70
80.0	12.95	2.50	17.20	1.20	20.35	0.69
79.0	14.10	2.49	18.15	1.19	21.25	0.69
78.0	15.10	2.45	19.10	1.17	22.15	0.68
77.0	16.20	2.30	20.10	1.15	23.05	0.67
76.0	17.25	2.17	21.10	1.12	24.00	0.67
75.0	18.25	2.06	22.15	1.10	24.85	0.65
74.0	19.20	1.95	23.15	1.07	25.70	0.64
72.0	21.10	1.76	25.05	1.02	27.45	0.62
70.0	23.00	1.59	26.80	0.97	29.10	0.61
68.0	24.90	1.47	28.60	0.93	30.65	0.59
66.0	26.75	1.35	30.30	0.90	32.25	0.58
64.0	28.60	1.24	32.00	0.87	33.80	0.57
62.0	30.40	1.10	33.70	0.84	35.30	0.56
60.0	32.00	0.87	35.25	0.72	36.75	0.55
59.0	32.80	0.76	36.00	0.66	37.45	0.55
58.0	33.60	0.64	36.60	0.58	38.20	0.54
Standard hook	for 4 ton					
Hook mass	120 kg					
Parts of line	1					
Critical boom angle	57 °					

(Unit : Metric ton)

Based on ISO 4305

Outriggers intermediately extended without front jack - 360° full range Outriggers fully extended without front jack - over front						
Boom angle (°)	43m Boom + 9.2m Jib					
	Offset 5°		Offset 25°		Offset 45°	
	Working radius(m)	Load (t)	Working radius(m)	Load (t)	Working radius(m)	Load (t)
81.0	10.00	3.50	12.75	2.30	14.60	1.25
80.0	11.05	3.50	13.70	2.30	15.45	1.25
79.0	12.05	3.42	14.65	2.30	16.30	1.24
78.0	12.90	3.05	15.60	2.25	17.20	1.23
77.0	13.65	2.67	16.45	2.06	18.05	1.21
76.0	14.50	2.27	17.20	1.76	18.90	1.19
Standard hook	for 4 ton					
Hook mass	120 kg					
Parts of line	1					
Critical boom angle	75°					

(Unit : Metric ton)

Outriggers intermediately extended without front jack - 360° full range Outriggers fully extended without front jack - over front						
Boom angle (°)	43m Boom + 15m Jib					
	Offset 5°		Offset 25°		Offset 45°	
	Working radius(m)	Load (t)	Working radius(m)	Load (t)	Working radius(m)	Load (t)
81.0	11.75	2.50	16.20	1.20	19.40	0.70
80.0	12.95	2.50	17.20	1.20	20.35	0.69
79.0	14.10	2.49	18.15	1.19	21.25	0.69
78.0	15.10	2.45	19.10	1.17	22.15	0.68
77.0	16.05	2.06	20.10	1.15	23.05	0.67
Standard hook	for 4 ton					
Hook mass	120 kg					
Parts of line	1					
Critical boom angle	76°					

(Unit : Metric ton)

## NOTES:

- (1) The rated lifting capacities are the maximum load guaranteed on a firm level ground and include the mass of hook block and other lifting equipment. The capacities enclosed with bold lines are based on the structural strength of machine and the others are based on the stability of machine.
- (2) The working radii as given in the table are the actual values including the deflection of the boom. Therefore, operate the machine based on the working radius. However, the working radii shown for jib operations are based on the values obtained when the boom is fully extended (43 m). Jib operations should be performed on the basis of boom angle only, regardless of boom length when the boom is not fully extended.
- (3) The rated lifting capacities for the rooster sheave are equivalent to the rated lifting capacities for the main boom to a maximum of 4000 kg. At all times the mass of all lifting equipment in use (including main hook block suspended from boom head) forms part of load and must be subtracted from the rated lifting capacity.
- (4) If the boom length exceeds the specified value, the rated lifting capacities for the boom length above and below the present boom length should be referred to, and the crane should be operated within the smaller lifting capacity.
- (5) When using the main boom with the jib installed, 2000 kg plus the mass of hook block and other lifting equipment, etc., should be subtracted from the rated lifting capacities.  
When performing the above operation, do not use the rooster sheave.
- (6) Critical boom angles for each boom length are shown on bottommost line of lifting capacity table.  
If the boom angle is lowered to less than the critical boom angle, the machine will tip over without load. Therefore, never lower the boom below these angles.

- (7) The standard number of parts of line is shown in the rated lifting capacity table.  
If you work with a non-standard number of parts of line, take 39.2kN (4tf) as the maximum load on any part of the wire rope.
- (8) Over front lifting performance is inferior to over side and over rear lifting performance. Great care should be taken when transferring from over side to over front since there is a danger of overloading.
- (9) Free fall is adopted in principle to lower the hook only.  
If it is necessary to lower a load by free fall, its mass should be less than 20 % of the rated lifting capacity and abrupt braking should not be allowed.
- (10) Crane operation is permissible up to a wind speed of 10m/s.  
Even in relatively light wind conditions, extra care should be taken when handling loads presenting large wind catching areas.
- (11) The machine will tip over or be damaged if operated with a load exceeding that specified in the rated lifting capacity table or not conforming to correct handling.  
If such trouble occurs, the machine will not be guaranteed.

KATO FULLY HYDRAULIC TRUCK CRANE MODEL NK-550VR  
(CARRIER : NISSAN DIESEL KG48U)

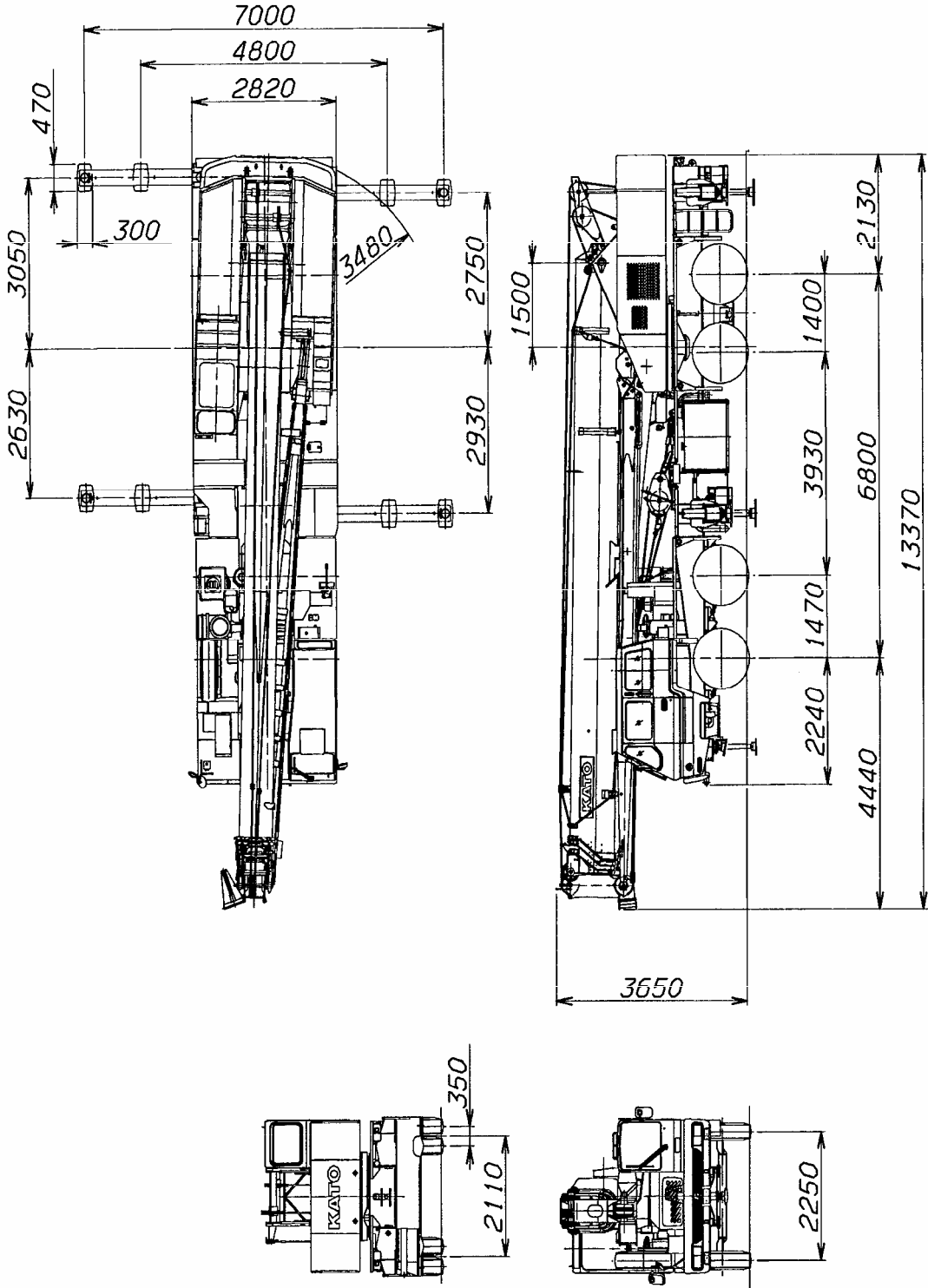



Standard equipment	
For crane	For carrier
<ul style="list-style-type: none"> <li>* Front jack</li> <li>* Fly jib</li> <li>* Rooster sheave</li> <li>* Independent two winches control system</li> <li>* Irregular winding prevention device</li> <li>* Winch automatic brake</li> <li>* Free fall device</li> <li>* Control pedals for main winch &amp; auxiliary winch</li> <li>* Sub hook sheave for 55t</li> <li>* Hooks ( 40 ton, 20 ton, 4 ton)</li> <li>* Hydraulic oil cooler</li> <li>* Full size fender</li> <li>* Large size steps</li> <li>* 3 working lights</li> <li>* Moment limiter with voice alarm (English)</li> <li>* Winch drum turning indicator</li> <li>* Sun visor</li> <li>* Cigar lighter</li> <li>* Ashtray</li> <li>* Cab floor mat</li> <li>* Tool kit</li> </ul>	<ul style="list-style-type: none"> <li>* Towing hook (front and rear, eye type)</li> <li>* Spare tire &amp; wheel</li> <li>* Air dryer</li> <li>* Cab heater</li> <li>* Radio AM</li> <li>* Cigar lighter</li> <li>* Ashtray</li> </ul>

Optional equipment	
For crane	For carrier
<ul style="list-style-type: none"> <li>* Winch over-unwinding device</li> <li>* Winch drum mirror (hoist mirror)</li> <li>* Yellow rev. light</li> <li>* Cab heater</li> <li>* Cab cooler</li> <li>* Fan</li> <li>* Radio AM FM</li> <li>* Fire extinguisher</li> </ul>	<ul style="list-style-type: none"> <li>* Cab cooler</li> <li>* Radio AM FM</li> </ul>

Performance and specifications are for cranes fitted with all standard equipment.

\*\*\*\*\*

WE RESERVE THE RIGHT TO MAKE SPECIFICATION  
AND EQUIPMENT CHANGES WITHOUT NOTICE

\*\*\*\*\*

CONCLUSION

This is the KATO NK-550VR specification, and should there be any further details you require information on, or any points you wish to have clarified, please do not hesitate to contact our Overseas Marketing Department at ; -

KATO WORKS CO., LTD.

9-37, Higashi-ohi 1-chome,  
Shinagawa-ku, Tokyo, 140 Japan

Phone : Head Office

Tokyo (03) 3458-1111

Overseas Marketing Dept.

Tokyo (03) 3458-1115

Fax. : Tokyo (03) 3458-1151

where our Overseas Marketing Dept. staff will be happy to assist you.