

Mantsinen LH32 Log Handler

Rethinking Wood Handling



More load, less energy

Mantsinen LH32 Log Handler - Technical specifications

OPERATING DATA

Operating weight	85 000 kg
Rated load max	32 000 kg
Staking height	8m
Grapple size (standard)	7,8 m ²
Forward reach at ground level	7,2 m
Travel speed	30 km/h
Turning radius	8,95 m

ENGINE

Manufacturer	Caterpillar
Model	CAT C15
N:r of cylinders	6
Output @ 1800 r/min ISO 3046	328 kW
Displacement	15,0 dm ³
Emission rate	EU Stage 3A

TRANSMISSION

Manufacturer	Caterpillar
Model	TR43 (CAT 824)
Gears FWD / REV	4 / 3
Control	automatic

DRIVE AXLE

Manufacturer	Mantsinen
Integrated in chassis	
Differential gear	CAT 988G
Planetary gears in hubs	CAT 769D
Width over tires	4 300 mm

STEERING AXLE

Manufacturer	Mantsinen
Steering cylinders	1
No subsequent adjustments	

WHEELS

Drive axle (dual)	18.00 – 33
Inflation pressure	10,0 bar
Steering axle (single)	18.00 – 33
Inflation pressure	10,0 bar

BRAKES

Service brakes:
 - Oil cooled wet disk brakes at drive axle
 - Brakes are hydraulic operated

Parking brakes:
 - Spring actuated handbrake
 - Hydraulic release

HYDRAULIC SYSTEM

Tank capacity	1 000 l
---------------	---------

Hydraulic pumps:
 - Variable axial piston pumps for all main functions
 - Total pump capacity 750 l/min

Max. pressure 250 bar

Valves:
 - Directional valves are electrically (proportionally) remote controlled
 - Boom and grapple can be operated simultaneously

Oil filters:
 - Continuous filtration 10 micron
 - Air filter in tank (breather)

BOOM

Telescopic boom with double action cylinder
 Welded "square pipe" construction
 Plastic slide pads
 Max. horizontal reach 4 200 mm

GRAPPLE

Standard grapple size 7,8 m²
 Width 0,9 / 1,35 m

Other sizes and types available
 Unlimited rotation in both direction
 2-way Grapple Carrier
 (longitudinal hydraulic tilt with damping)

ELECTRIC SYSTEM

Voltage 24 V
 Battery 180 Ah
 Alternator 24 V / 95 Amp
 Electronic control system, CAN-bus

CABINE

Large cabin with air suspended seat
 Seat for trainer
 Safety tested according to ISO 6055-1979

EQUIPMENT

Standard:
 - Stack pusher
 - Automatic lubrication (Lincoln)
 - Air conditioning
 - Wheel & buttom steering
 - Automatic gear control system
 - Fire extinguisher 2 pcs

Optional:
 - Automatic Fire extinguisher system
 - Back camera with monitor in the cabin
 - Grapple 8,2 m², 8,7m² and 9,0 m²
 - 4 way Grapple Carrier
 (longitudinal + sideway hydraulic tilt with damping)

Specifications subject to change without prior notice.

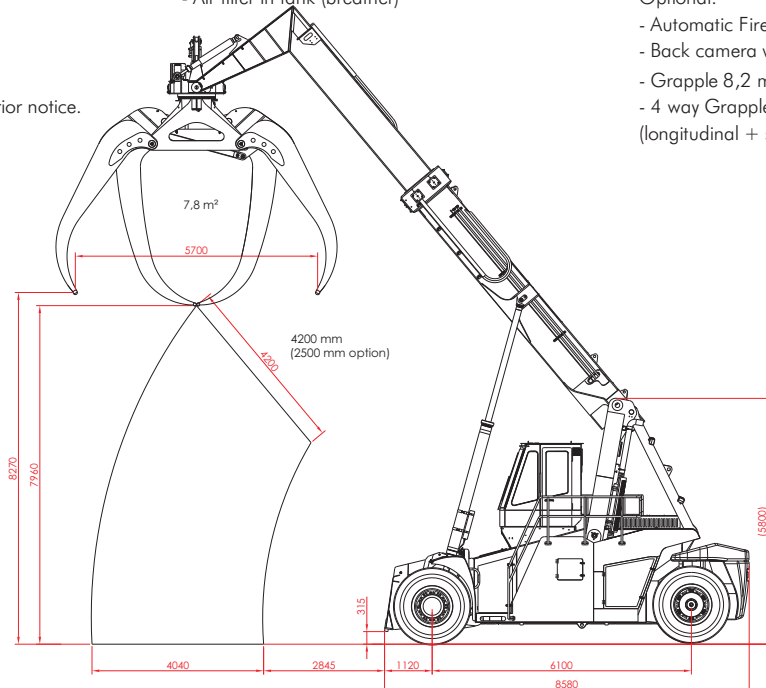

More load,
 less energy

Mantsinen Group Ltd Oy
 Välikankaantie 3
 FI-80400 Ylämylly
 FINLAND

Tel +358 20 755 1230
 Fax +358 13 252 5555
 www.mantsinen.com