

6/39 Lifting Capacities

6/39 - 1 Hydraulic

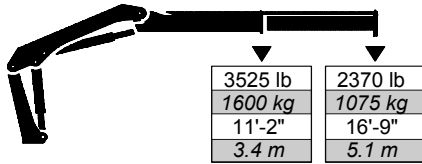

6/39 - 2 Hydraulic

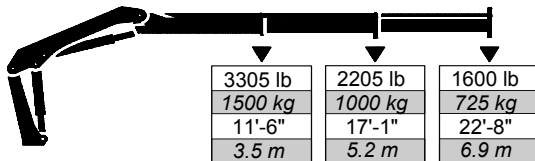

6/39 - 3 Hydraulic

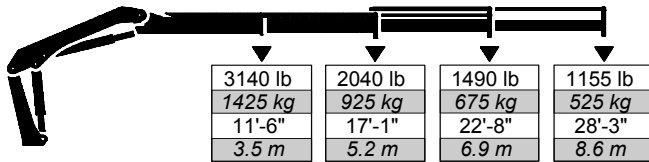

6/39 - 4 Hydraulic

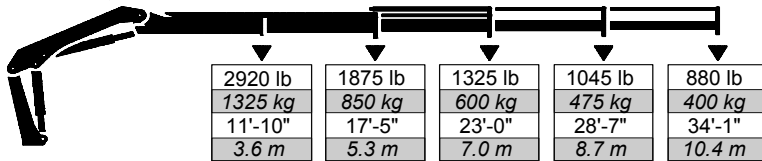

Minimum Chassis Specifications

Front Axle Rating (GAWR)	6000 lb (2720 kg)
Rear Axle Rating (GAWR)	12,460 lb (5650 kg)
Resistance To Bending Moment	540,000 in-lb (62,215 kg-m)



Note: Crane appearance subject to change.

6/39 Specifications

Outrigger Pad Diameter	5.5" (140 mm)
Crane Storage Height	6' 1" (1843 mm)
Mounting Space ***	1' 11" (583 mm)
Rotational Torque	7090 ft-lb (980 kgm)
Rotation	400°
Optimum Pump Performance	6.6 gpm (25 lpm)
System Pressure	3990 psi (275 bar)
Oil Reservoir Capacity	8.8 gal (33.5 l)
Outrigger Extension Span	
Standard (manual out /hydraulic down)	11' 2" (3400 mm)
Weight	265 lb (120 kg)
Option 1 (manual out / hyd. down)	15' 7" (4760 mm)
Weight	340 lb (155 kg)
Option 2 (hyd. out / hyd. down)	18' 1" (5500 mm)
Weight	395 lb (180 kg)

6/39	1 - Hydraulic	2 - Hydraulic	3 - Hydraulic	4 - Hydraulic
Crane Rating*	39,060 ft-lb (5.4 tm)	37,610 ft-lb (5.2 tm)	36,890 ft-lb (5.1 tm)	34,720 ft-lb (4.8 tm)
Maximum Horizontal Reach	17' 1" (5.2 m)	23' 0" (7.0 m)	28' 7" (8.7 m)	34' 5" (10.5 m)
Maximum Vertical Reach	23' 4" (7.1 m)	29' 2" (8.9 m)	35' 1" (10.7 m)	41' 0" (12.5 m)
Maximum Capacity	3525 lb (1600 kg)	3305 lb (1500 kg)	3141 lb (1425 kg)	2920 lb (1325 kg)
Max Cap @ Max Reach	2370 lb (1075 kg)	1600 lb (725 kg)	1155 lb (525 kg)	880 lb (400 kg)
Crane Weight **	1630 lb (740 kg)	1795 lb (815 kg)	1940 lb (880 kg)	2070 lb (940 kg)
Hook Approach				
Vertical	8' 0" (2.44 m)	7' 8" (2.34 m)	7' 4" (2.23 m)	7' 0" (2.13 m)
Horizontal	2' 9" (0.84 m)	2' 11" (0.89 m)	3' 1" (0.94 m)	3' 3" (1.0 m)
Center of Gravity - Stored				
Vertical	1' 10" (561 mm)	1' 10" (566 mm)	1' 10" (570 mm)	1' 11" (573 mm)
Horizontal (C/L RotTo Bridge)	7.5" (190 mm)	7" (182 mm)	6.5" (165 mm)	6" (152 mm)

* Crane rating (ft-lb) is the rated load (lb) multiplied by the respective distance (ft) from centerline of rotation with all extensions retracted and the inner and outer booms in a horizontal position, per ANSI B30.22. ** Crane weight does not include outriggers.

*** Maximum swing clearance radius required is 22" (556 mm) at 7'-2" (2193 mm) from top of chassis frame.

© 2009 Iowa Mold Tooling Co., Inc. All Rights Reserved.



An Oshkosh Corporation Company

Geometric Configurations

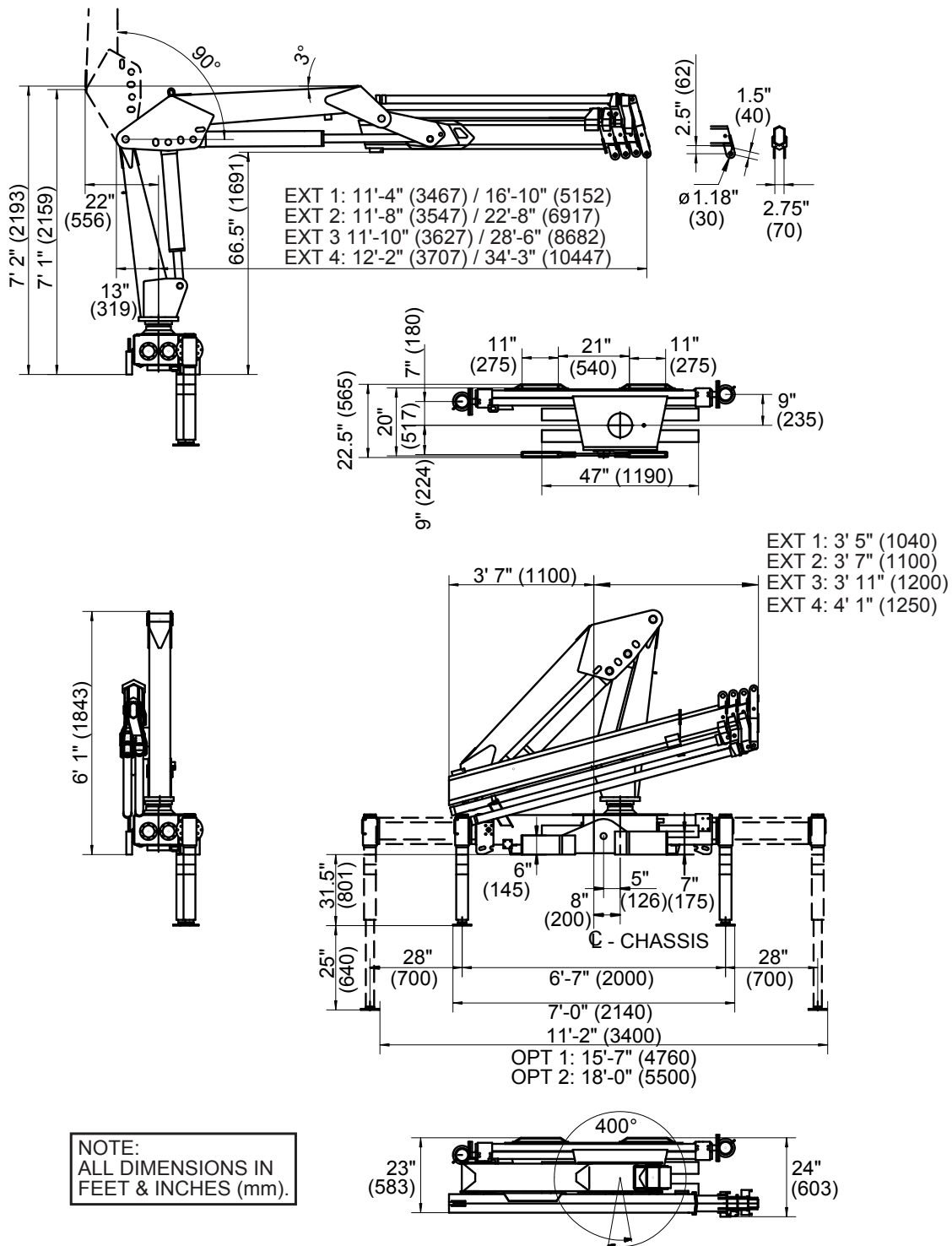

Iowa Mold Tooling Co., Inc.

500 Highway 18 West P.O. Box 189 Garner, Iowa 50438-0189
 800-247-5958 641-923-3711 Fax: 641-923-6063 www.imt.com

IMT reserves the right to make changes in engineering, design, and specifications; add improvements; or discontinue manufacturing at any time without notice or obligation.

IMT and the IMT LOGO are registered trademarks or trademarks of Iowa Mold Tooling Co., Inc., Garner, IA, USA.

© 2009 Iowa Mold Tooling Co., Inc. All Rights Reserved.