

National Series 500B

**A high-capacity telescoping crane from National,
America's truck-mounted hydraulic crane leader**

Maximum Capacity: 25,000 Pounds (11.2 Metric Tons)

Maximum Height: 118 Feet (36 Meters)



Why buy a National Series 500B?



National Crane, America's truck-mounted hydraulic crane leader, features the industry's premier lineup of hard-working telescoping and articulating units. The medium-to-heavy-duty Series 500B telescoping crane (12½-ton capacity; 118-foot vertical reach) offers many advantages:

Field-proven durability

- National has manufactured cranes since 1963.
- More than 17,000 field-proven cranes verify National's manufacturing expertise.
- Nearly 90% of all National cranes ever manufactured are working on the job today.

Attention to quality

- National's industry leading testing program subjects all prototype models to state-of-the-art strain gauge and life-cycle testing to verify structural integrity.
- Each 500B undergoes numerous quality inspections at all levels of manufacture and assembly. All mounted cranes are fully tested prior to shipment.

Retained market value

- National cranes traditionally retain higher resale value year after year.

Responsive service

- Each 500B is backed by strong after-sale and ser-

vice support. National's professional, factory-trained dealer network spans the nation.

- Authorized National dealers maintain a parts stocking program for your 500B.
- When a dealer cannot immediately supply a part, the factory's back-up program provides 24-hour parts shipping in 90% of all breakdown rush orders.

Strong warranty protection

- The 500B is backed by a solid warranty covering defects in materials and workmanship for six months from date of shipment.

Efficient boom design

- Computer-aided design enables National to improve the weight efficiency of 500B boom sections.

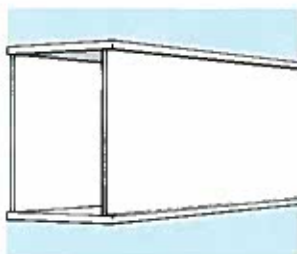

- Telescoping boom sections are fabricated from four high-strength steel members welded with perpendicular corners. This "box-section" boom design has thicker top and bottom

plates to maximize strength and thinner side plates to increase capacity through lower boom weight.

- Only strong, low-alloy steel is used in boom fabrication.
- Welds are made with automatic, low-hydrogen techniques to ensure strong seams.
- Corner seams are ultrasonically tested for proper weld penetration.
- Large nylon bolt-in wear pads impregnated with lubricants provide a smooth, long-life operation and are easily replaced.

Proportional boom extension

- Proportional (cable crowd) boom extension (each section extends and retracts proportionally during the telescoping operation) maximizes efficiency and yields higher capacities (particularly in normal working radii) through efficient boom weight distribution.
- The design permits minimum overlap to get the most reach with minimum retracted length for maneuverability.
- The utilization of cable, rather than chain, means longer service life and less maintenance.
- The boom extend cylinder is fully protected with a direct mount holding valve.
- There are no fitting tubes or hoses inside the boom, and since the system utilizes only one extend cylinder, hydraulic maintenance is minimized.

Planetary winch

- The standard high performance planetary gear drive winch increases efficiency, requires less horsepower, and generates less heat.
- Equipped with a special gerotor motor for extra-smooth full-load operation.
- Anti-friction bearings are used throughout to maximize efficiency and seal life.

- A "Burst-of-Speed" option, increasing line speed up to 60% over normal, allows extra fast payout and pickup of unloaded cable.
- Standard brake and counterbalance valves provide fine control.
- A rotation indicator allows the operator to readily determine that the drum is rotating.
- The winch cover permits visibility of the drum and cable.
- Rotation-resistant 9/16" diameter cable is standard.

Positive planetary turret rotation

- The planetary rotation gearbox with a hydraulic release brake allows the gearbox to backdrive when excessive side load is applied to the boom, reducing shock loads on the upper and lower crane structure and gearbox.
- The turret drive is designed with extra-heavy bearings below the drive pinion. The turntable bearing full-circle bolt pattern extends the bearing life due to uniform loads on the bearing.
- The gearbox and rotation bearing mounting surfaces are precision-machined after welding to ensure consistent tooth alignment for smooth rotation and low wear, even under maximum loads.

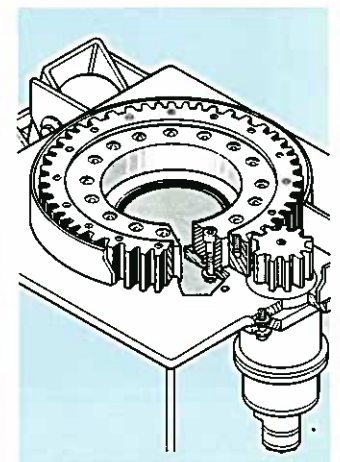

- The entire turret glides smoothly on a low-inertia ball bearing race.
- Rotation is 370° non-continuous. The rotation stop design eliminates the sudden stop on non-continuous rotation machines by gradually slowing the rotation of the boom.
- A turret rotation indicator aids the operator in positioning loads.

Solid, reliable stability

- Wide 18-foot-span A-frame out-and-down outriggers provide stable, efficient leveling, even on uneven ground. Large 13" x 16" outrigger pads are standard.



- The outriggers retract smoothly, without binding under load, first moving up, then in.
- Outrigger and stabilizer hydraulic power is sufficient to level a fully loaded truck.
- Heavy-duty A-frame (ASH) hydraulic rear stabilizers with an extended 10-foot span are standard.
- The outrigger location (behind operator) permits occasional 360° working area without front stabilizers when mounted on a recommended truck.
- Optional hydraulic rear out-and-down stabilizers with a 14-foot span provide stability with less counterweight and are designed to lift, level and lower a loaded truck without sticking or binding. Horizontal extension is controlled by one cylinder; the vertical-down motion is

controlled by two cylinders acting independently.

- A precision-mounted level indicator at each control station aids the operator in leveling the 500B during the set-up procedure.

Protection features

- A standard anti-two-block sensory device helps prevent cable damage caused by two-blocking (i.e., when the winch cable or attachments contact the underside of the boom sheave case, either by winching up or extending the boom without paying out the winch cable).



- The 500B features holding valves on all cylinders.

Mounting features

- Seven standard mounting configurations are available.
- The 500B can be mounted on selected, single-axle trucks (Model 566B requires a tandem-axle truck).
- National's unique "tab-and-slot" shear plate mounting



is exceptionally strong, yet a simple method of mounting the crane.

- A subbase is available to eliminate truck reinforcing and, in some cases, counterweight.

Easy service, low downtime

- Boom access holes enhance serviceability and allow viewing of the extension system.
- The 500B frame allows easy access to control valves and plumbing for minor adjustments and fitting tightening. Oil and control valves are located externally for improved serviceability.
- The complete console is easily removable for major repair.
- The simplicity of the boom design permits fast disassembly.

Dual operator stations

- Standard dual operator stations feature identical controls in a SAE orientation of functions (you always work the same control with the same hand).
- Extra-fine metering and low spool forces allow smooth, precise control.
- Control rods supported by nylon bearings permit smooth, low-maintenance operation.
- Dual stations and convenient platform positioning provide the operator with excellent load visibility.

- Labeled control knobs identify the function of each control.

- A system pressure gauge enables the operator to monitor pressures on all control functions.
- Each station is equipped with foot throttles controlling the engine speed.
- Kill and audible warning switches are located at each station.
- The operator's stations are positioned to allow easy reading of the angle indicator showing the boom angle during crane operation.

Compact design

- The 500B fits into just 46½" of bed space, leaving ample space for payload.
- The operator platforms are designed with open-mesh expanded metal to minimize dirt and mud buildup.

Heavy-duty hydraulic system

- A standard high-pressure, high-speed balanced vane replaceable tandem pump provides for a smooth, fast, simultaneous operation. The winch is isolated from other crane functions, providing an independent operation capability.
- Control valve spools are hard, chrome-plated for long life and resistance to corrosion. All spools are selected hone-fitted for minimum internal leakage and maximum load-holding ability.
- The aluminized hydraulic reservoir prevents the gathering of rust in the system, keeping the hydraulic oil clean.

Versatile accessories

- A selection of boom/jib combinations (see the following chart) allows you to tailor your 500B to your job requirements.
- A comprehensive accessory line (see backside of this brochure) adds to the versatility of your 500B.

National Series 500B Booms and Jibs

Boom and Jib Combinations

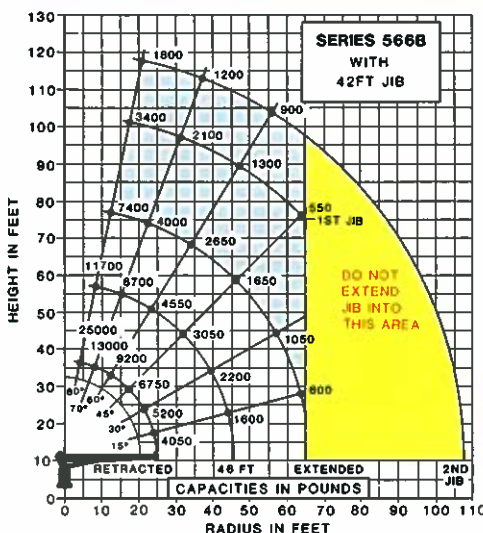
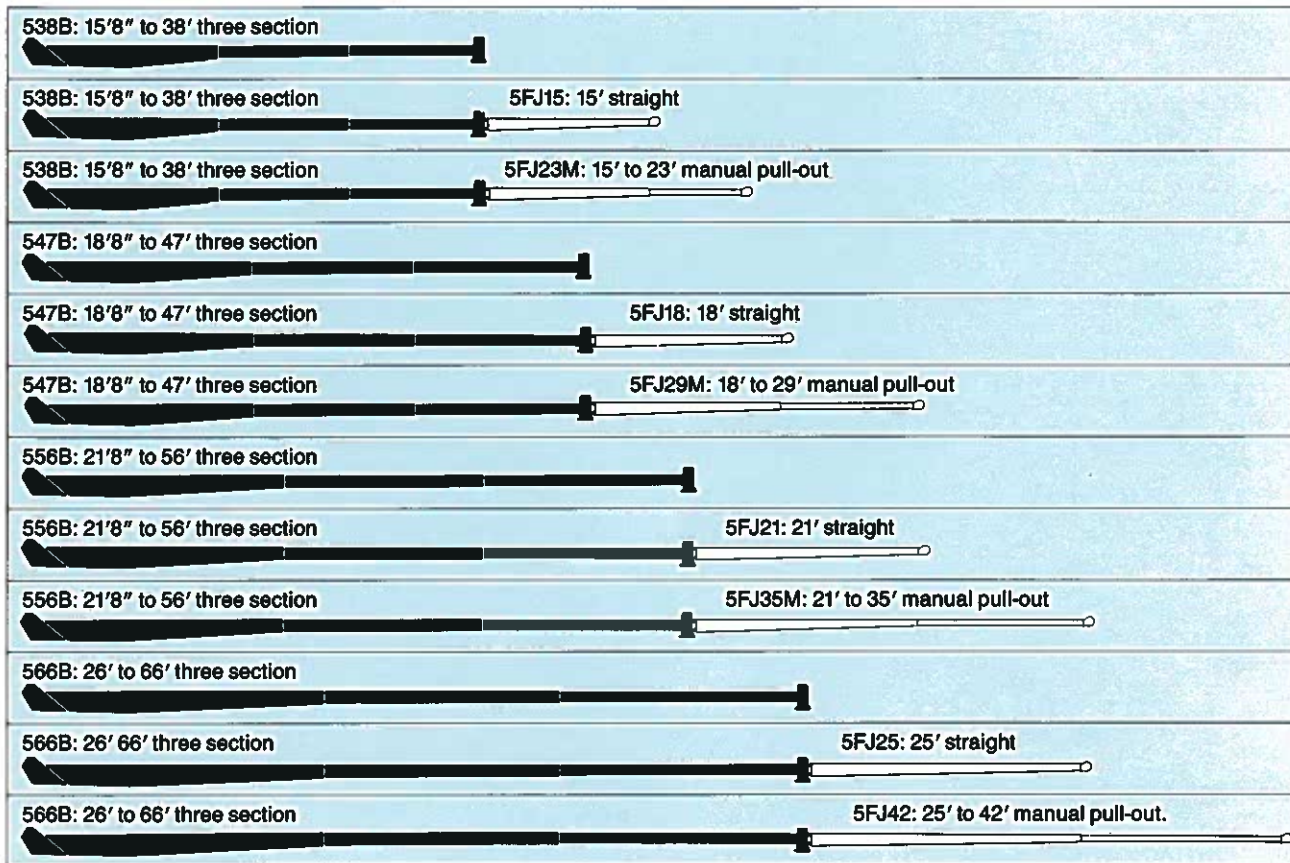

556B Capacity*
(Metric equivalents shown in parentheses)

Radius	All Booms Retracted	Extended 46 Feet	All Booms Extended Maximum
Maximum Capacity	25,000 lbs. (11,340kg.)	15,200 lbs. (6,849kg.)	
8' (2.4m)	18,300 lbs. (8,300kg.)	10,800 lbs. (4,898kg.)	9,400 lbs. (4,263kg.)
12' (3.7m)	12,500 lbs. (5,670kg.)	8,150 lbs. (3,696kg.)	7,250 lbs. (3,288kg.)
16' (4.9m)	9,200 lbs. (4,173kg.)	6,650 lbs. (3,016kg.)	5,950 lbs. (2,698kg.)
20' (6.1m)	8,800 lbs. (3,984kg.)	5,500 lbs. (2,494kg.)	4,950 lbs. (2,245kg.)
24' (7.3m)		4,650 lbs. (2,109kg.)	4,200 lbs. (1,905kg.)
28' (8.5m)		3,900 lbs. (1,769kg.)	3,600 lbs. (1,632kg.)
32' (9.8m)		3,150 lbs. (1,428kg.)	3,150 lbs. (1,428kg.)
36' (11.0m)			2,750 lbs. (1,247kg.)
40' (12.2m)			2,400 lbs. (1,089kg.)
44' (13.4m)			2,050 lbs. (929kg.)
48' (14.6m)			1,700 lbs. (771kg.)
52' (15.9m)			

*Capacities shown are for the 556B with the load suspended. Radius shown includes increase due to boom deflection. Capacities vary for cranes equipped with jibs or attachments. Consult factory for specific load rating information.

500B Buyer's Guide

Contact your National dealer for a **Series 500B Buyer's Guide**, a 20-page booklet with detailed information about Series 500B telescoping cranes, including:

- Load rating charts for all Series 500B models
- Winch data information
- Truck requirements
- Series 500B specifications
- Options and accessories

The capacities shown will be reduced when accessories are attached to the boom or loadline.



Do not operate cranes or accessories within 10 feet of live power lines.

1. Load ratings shown on these charts are maximum allowable loads with the outriggers properly extended on a firm, level surface and the crane leveled

and mounted in a factory-recommended configuration.
2. Always level the crane with the level indicator on the crane frame.
3. The operator must reduce loads to allow for such factors as wind, ground conditions, operating speeds and the effect of freely suspended loads.

4. Overloading the crane may cause structural collapse or instability.
5. Weights of any accessories attached to the boom or loadline must be deducted from the load chart capacities.
6. Do not exceed jib capacities at any reduced boom length.

National Series 500B

NATIONAL CRANE CORPORATION
To provide our customers with products where Quality and Reliability are integral with design and manufacturing.
COMMITMENT TO QUALITY

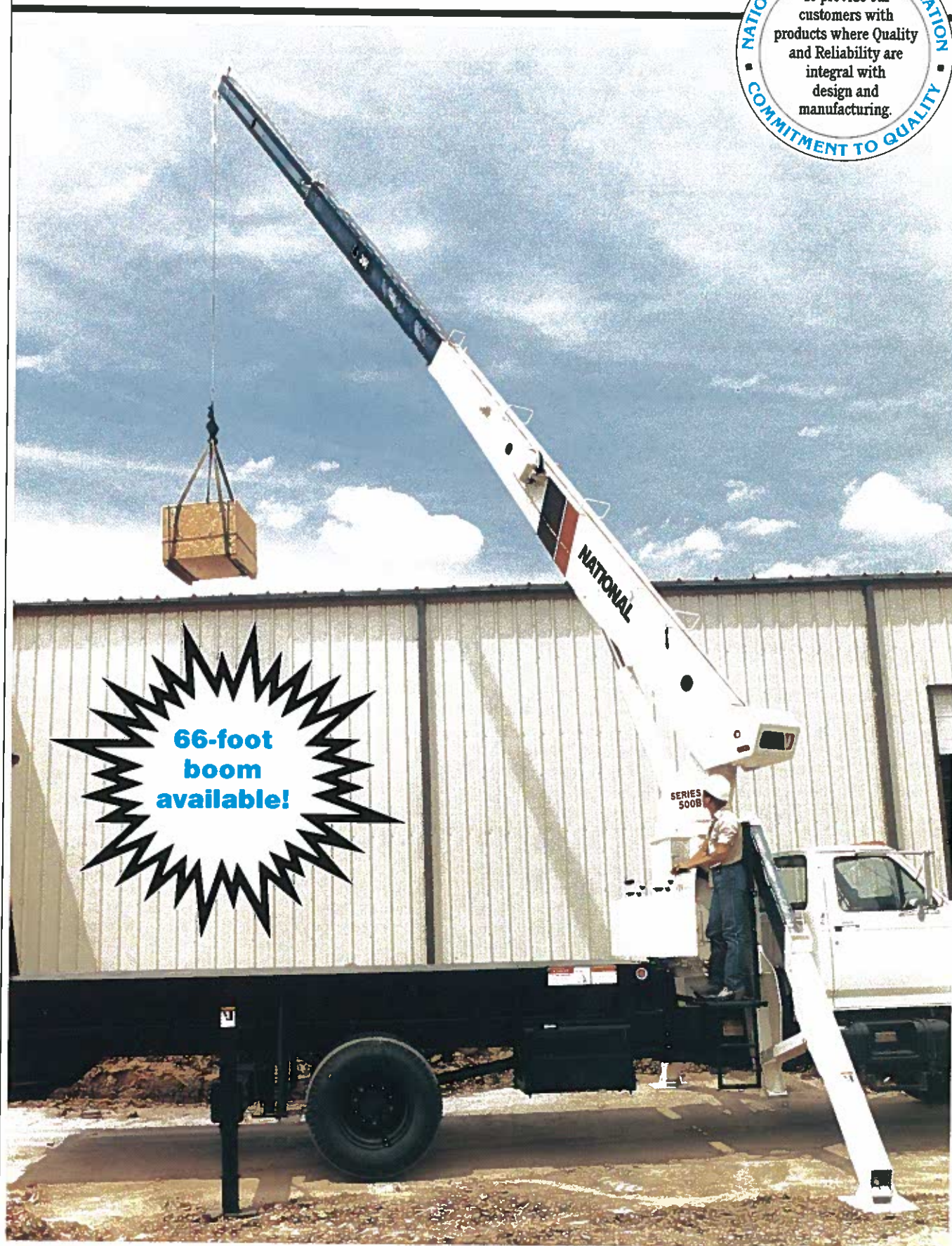

**66-foot
boom
available!**

SERIES 500B

National Series 500B Truck/Crane Specifications

Truck Specifications

The 500B can be mounted in several configurations, including the one shown below. Your National dealer can provide you with detailed information about alternative configurations (with and without torsion boxes, rear mounts, etc.). Specifications vary, depending on the configuration utilized. The mounting configuration below is based on an 85% stability factor. The complete unit must be installed in accordance with factory requirements, and a test must be performed to determine actual stability and counterweight requirements since individual truck chassis vary.

This configuration allows installation of the Series 500B on a chassis with a small frame by using the standard subbase. In most cases, the chassis will not require reinforcing and the amount of counterweight required is minimized, increasing payload capabilities. Requires standard subbase and RSH rear stabilizers. Full capacity work area is rear 180° of vehicle from outrigger to outrigger.

Gross Vehicle Weight Rating (GVWR)	29,360 lbs.
Gross Axle Weight Rating (GAWR), Front	10,860 lbs.
Gross Axle Weight Rating (GAWR), Rear	18,500 lbs.
Wheelbase (WB)	184" on Model 538B*
Cab to Axle/Trunnion (CA/CT)	120" on Model 538B*
Frame Section Modulus (SM) over Rear Stabilizers	
50,000 PSI	13.7-inch ³
or	
110,000 PSI	10.8-inch ³
Stability Weight, Front**	5,500 lbs. minimum 6,500 lbs. maximum
Stability Weight, Rear**	5,500 lbs. w/RSH stabilizers
Estimated Average Final Weight	25,000 lbs.

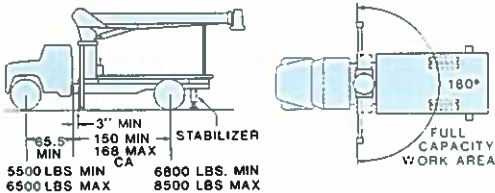

* Longer WB, CA/CT required for 547B, 556B, 566B.
 ** Estimated axle scale weights prior to installation of crane, stabilizers and subbase if required for 85% stability.

Notes:

- GAWR means Gross Axle Weight Rating and is dependent on all components of the vehicle, such as axles, tires, springs, frame, etc., meeting manufacturer's recommendations. **Always specify GAWR when purchasing trucks.**
- Minimum axle requirements may increase with the use of longer wheelbase, service bodies, diesel engines, or front stabilizers.
- Tandem axle trucks must be used for hauling larger payloads.
- Diesel engines require variable speed governor and electric engine shut-off.

Series 500B Dimensions

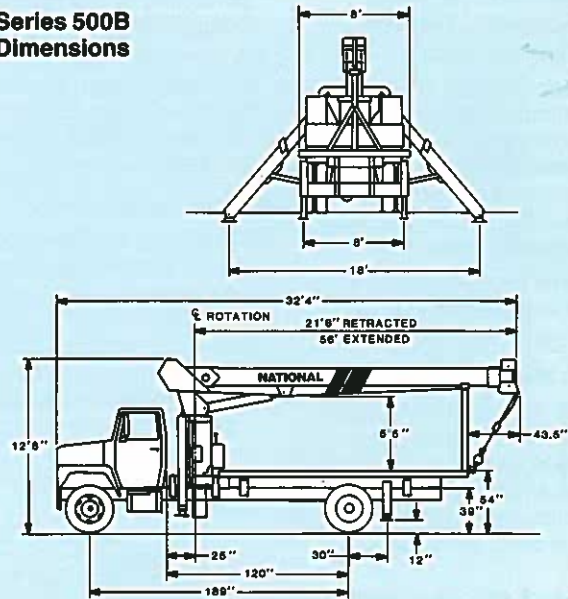

Optional Equipment

- Remote controls (Models R3, R4)
- Burst-of-speed planetary winch feature for faster, more efficient pay-out and pick-up of cable (Model BOS)
- One-person fiberglass basket (Models B1, B1-L)
- Two-person basket (Model BS-1)
- High-performance piston motor winch (Model PMW)
- Pallet fork (Model MKF)
- Loose material clam bucket (Model LMC)
- Rear hydraulic stabilizers with 14-foot span (Model RSOD)
- Rear hydraulic stabilizers with 6-foot or 8-foot span (Models RSH-15/18/25)
- Rear hydraulic A-frame stabilizers with 10-foot span (Model ASH)
- Front-mounted hydraulic stabilizer (Model SFO)
- Cross frame outriggers with 15½-foot span (Model 5HO)
- Capacity alert systems (Models AAs, HAS)
- Hydraulic oil cooler (Model HOC)
- Three pump system (Model TP3)

Do not operate National cranes or accessories within 10 feet of live power lines or other electrified sources. Weights of all accessories attached to the boom or loadline of the crane must be deducted from the effective lifting capacity. Some accessories cannot be used in combination with other accessories and/or certain boom/jib combinations. See your National dealer for details and specific accessory availability.



NATIONAL CRANE
 General Offices: 11200 North 148th Street / Waverly, NE 68462
 Phone: 402-786-6300 / Telex: 438061 / FAX: 402-786-6363

Your National Dealer:

National reserves the right to change designs, prices, and specifications at any time without notice.