

SCX1000A-3

Stage III A, Tier 3

***SCX
1000A-3***

HYDRAULIC CRAWLER CRANE

***Specifications
&
Lifting Capacities***

Hoist Rope 26mm

HITACHI SUMITOMO



1308(B)01T.EA216

Variation of The Attachment

Line Speed *	Front / Rear Winch (Rated with 12 t load)	m/min	110 (45)
	Third Winch (Rated with 12 t load)		95 (30)
Swing Speed	min ⁻¹ (rpm)		2.3
Travel Speed High / Low *	km/h		2.0 / 1.1
Gradeability	% (Degree)		30 (17)
Engine Model		ISUZU 6HK1 (Stage III A, Tier 3)	
Engine Rated Output Power	kW/min ⁻¹ (ps/rpm)		200.6 / 1850 (272 / 1850)

Note : Speeds marked with "*" may vary depending on load applied.

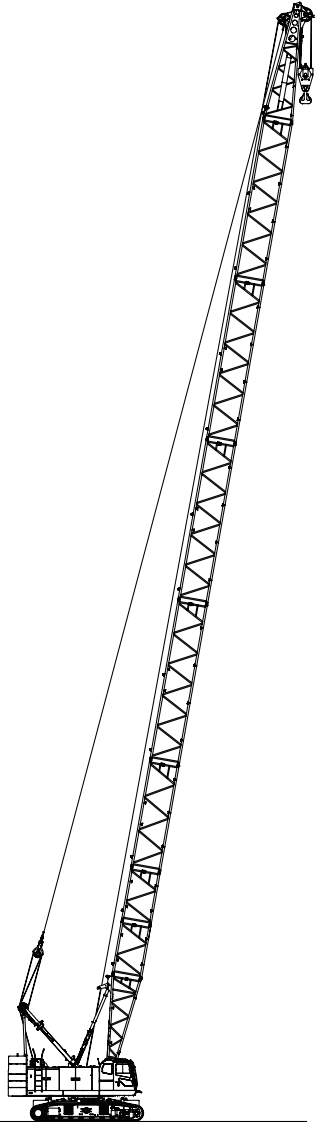

**Crane Specification
(Boom Longest Length)**

Boom Length	m	12 to 60
Ground Contact Pressure	kPa (kgf/cm ²)	123 (1.25) (Boom longest length with 35 t hook)
Overall Operating Weight	t	Approximately 109 (Boom longest length with 35 t hook)

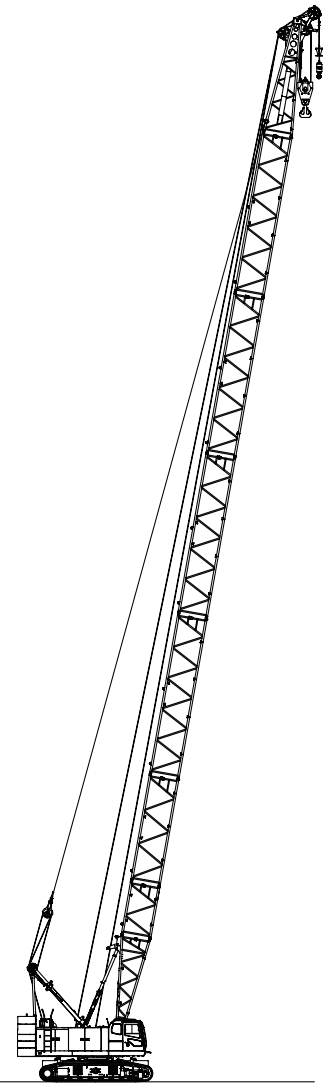

**Crane Specification
(Boom Longest Length with Aux. Sheave)**

Boom Length	m	12 to 57
Ground Contact Pressure	kPa (kgf/cm ²)	123 (1.26) (Boom longest length + 35 t aux. sheave + 12 t hook attached)
Overall Operating Weight	t	Approximately 110 (Boom longest length + 35 t aux. sheave + 12 t hook attached)

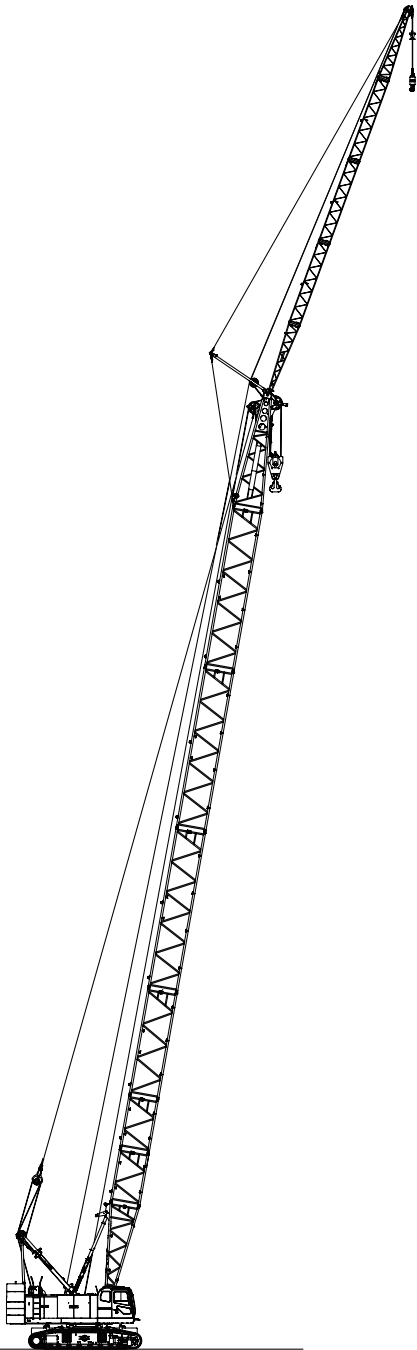

**Crane Specification
(Boom Longest Length with Crane Jib)**

Boom Length	m	24 to 51
Crane Jib Length	m	10 to 28
Boom + Crane Jib Longest Length	m	51 + 28
Ground Contact Pressure	kPa (kgf/cm ²)	123 (1.25) (Boom + crane jib longest length 35 t + 12 t hook attached)
Overall Operating Weight	t	Approximately 109 (Boom + crane jib longest length 35 t + 12 t hook attached)

VARIATION

Variation of The Attachment	2
------------------------------------	----------

SPECIFICATIONS

Specifications	6
-----------------------	----------

Crane Specifications	7
-----------------------------	----------

Dimensions and Specifications	7
--	----------

Boom and Crane Jib Configurations	8
--	----------

Combination of Boom and Crane Jib (Offset Angle 10° and 30°)	9
---	----------

Working Ranges	10
-----------------------------	-----------

■ Main Boom	10
-------------------	----

■ Aux. Sheave	11
---------------------	----

■ Main Boom with Aux. Sheave	12
------------------------------------	----

■ Main Boom with 10 m Crane Jib	13
---------------------------------------	----

■ Main Boom with 16 m Crane Jib	14
---------------------------------------	----

■ Main Boom with 22 m Crane Jib	15
---------------------------------------	----

■ Main Boom with 28 m Crane Jib	16
---------------------------------------	----

■ Main Boom with 10 m Crane Jib (Offset Angle 10°)	17
--	----

■ Main Boom with 10 m Crane Jib (Offset Angle 30°)	18
--	----

■ Main Boom with 16 m Crane Jib (Offset Angle 10°)	19
--	----

■ Main Boom with 16 m Crane Jib (Offset Angle 30°)	20
--	----

■ Main Boom with 22 m Crane Jib (Offset Angle 10°)	21
--	----

■ Main Boom with 22 m Crane Jib (Offset Angle 30°)	22
--	----

■ Main Boom with 28 m Crane Jib (Offset Angle 10°)	23
--	----

■ Main Boom with 28 m Crane Jib (Offset Angle 30°)	24
--	----

Gross Rated Load Table	25
-------------------------------------	-----------

■ Main Boom	25
-------------------	----

■ Aux. Sheave	26
---------------------	----

■ Main Boom with Aux. Sheave	27
------------------------------------	----

■ Crane Jib	28
-------------------	----

■ Main Boom with Crane Jib	35
----------------------------------	----

■ Main Boom (Using Third Winch)	38
---------------------------------------	----

■ Main Boom with Aux. Sheave (Using Third Winch)	39
--	----

Clamshell Specifications	40
<hr/>	
Dimensions and Specifications	40
■ Working Ranges.....	40
■ Specifications	40
■ Clamshell Bucket.....	40
■ Gross Rated Load Table.....	40

TECHNICAL DATA

Weights and Dimensions of Disassembled Units	41
<hr/>	
Weights and Dimensions List	41
Equipment List	45
<hr/>	
Standard and Optional Equipment	45

Specifications

Engine

Model	ISUZU 6HK1
Type	4-cycle, Water-cooled, Direct injection, Turbo-charged, Diesel engine
Displacement	7.79 liters
Rated Output	200.6 kW / 1,850 min ⁻¹ (272 ps / 1,850 rpm)
Fuel Tank Capacity	460 liters
Notes	Engine meets Stage III A / Tier 3 of engine exhaust gas emission regulations in USA, Europe, and Japan. Engine rated horsepower is based on international rating formula that includes engine alternator and without fan.

Control

Control System	Main actuators are actuated by main hydraulic system controlled with pilot hydraulic system. Safety devices are securely operated by combined various electronic control with hydraulic system. Working speed can be precisely controlled according to control lever stroke and control dials depending on work.
Control Levers	Designed and positioned based on ergonomics. Arm-chair lever type is standard. Cross operation lever type and front lever type are available as option.
Display Panel Design	8 inches size. Located to check work state easily without disturbing the view of the operator.

Hydraulic System

Hydraulic Oil Tank Capacity	320 liters		
Hydraulic Pump Capacity	Max.	31.4 MPa	
	P1	265 liters / min	for Front, Rear, boom hoist winch and travel
	P2	265 liters / min	for Front, Rear, third winch and travel
	P3	148 liters / min	for Swing, Jack, Sideframe retract and Gantry cyl.
	P4	38 liters / min	Pilot control, Brake cooling, Reeving tagline, etc.
	P5	38 liters / min	
	P6	38 liters / min	
P7	29 liters / min		

Winch

Front and Rear Winch				
Winch	Front	Rear		
Rope Diameter	26 mm	26 mm		
Rope Length	Incorporated	205 m	125 m	for Aux. sheave
	Max. for Work	300 m	300 m	for Crane jib
	Max. for Non Work	360 m	360 m	
Line Pull	Rated	117 kN	117 kN	
	Max. at 1st Lay	215 kN	215 kN	
Standard Equipment	Free fall winch with brake controlled by pedal operation. High-speed winching is possible by ECO winch mode with low engine speed under light loads.			

Boom Hoist Winch

Rope Diameter	22.4 mm		
Rope Length	Incorporated	160 m	
Hydraulic motor with multi-disc brakes.			

Third Winch

Rope Diameter	26 mm		
Rope Length	Incorporated	205 m	
	Max. for Work	170 m	
	Max. for Non Work	220 m	
Line Pull	Rated	117 kN	
	Max. at 1st Lay	215 kN	
Optional Equipment	Free fall winch with brake controlled by pedal operation.		

Swing System

Consisted of 2 hydraulic motors with reduction gear and multi-disc brakes and a swing bearing which has inner tooth. Optional swing brake pedal enables operator to control swing precisely.

Gantry

Gantry is welded steel construction. Raised and lowered by power hydraulic cylinders.

Counterweight

Upper Weight	Total Weight	37.5 ton
	9.5 ton Base Weight	1 piece
	6.6 ton Insert Weight	2 pieces
	9.0 ton Insert Weight	1 piece
	2.8 ton Top Weight	1 piece
Lower Weight	3.0 ton Top Weight	1 piece
	Total Weight	12.0 ton
	6.0 ton Lower Weight	2 pieces

Carbody Frame

Welded steel construction with jack up device and crawler sideframe extend-retract cylinders.

Crawler Sideframe

Frame	Welded steel box construction, and can be retracted.		
Crawler Shoe	Cast iron 810 mm width shoes each side.		
Upper Roller	2 pieces double flange type for each side.		
Lower Roller	10 pieces each side.		
	Forging heat treated steel with double flange type. 2 plane bearing with floating seal for lifetime lubrication.		
Travel Device	1 piece each side.		
	Hydraulic travel device (Hydraulic motor and reducer)		
	Travel speed	High : 2.0 km/h	
	(Gradability : 30%)	Low : 1.1 km/h	

Crane Specifications

Dimensions and Specifications

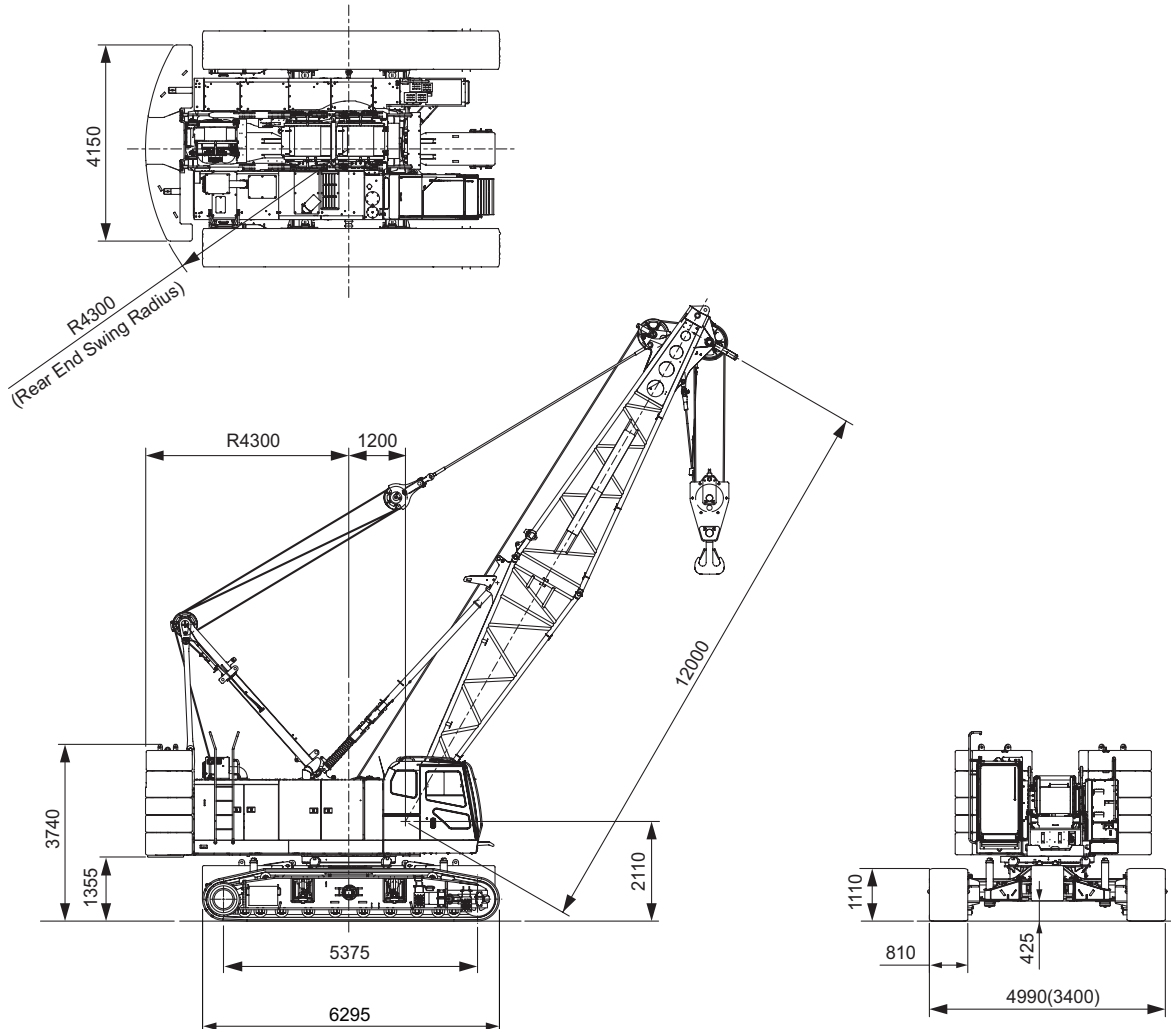

Crane Specifications

Max. Lifting Load × Working Radius	t × m	100×3.8
Basic Boom Length	m	12
Max. Boom Length	m	60
Max. Crane Jib Length	m	10 to 28
Max. Boom + Jib Length	m	51 + 28
Ground Contact Pressure	kPa (kgf/cm ²)	116 (1.18) (w / Basic Boom, 100 t Hook)
Overall Operating Weight	t	Approximately 103 (w / Basic Boom, 100 t Hook)

Hook Weight

100 t	1,200 kg
50 t	1,170 kg
35 t	900 kg
12 t	510 kg

NOTE : Data is expressed in SI units followed by conventional units in ().

Boom and Crane Jib Configurations

Boom	
Boom Length (m)	Boom Configurations
12	
15	
18	
21	
24	
27	
30	
33	
36	
39	
42	

Boom	
Boom Length (m)	Boom Configurations
45	
48	
51	
54	
57	
60	

Aux. Sheave Installable Boom Length																	
Boom Length (m)	12	15	18	21	24	27	30	33	36	39	42	45	48	51	54	57	60
With Aux. Sheave	○	○	○	○	○	○	○	○	○	○	○	○	○	○	○	○	×

(○: Attachable ×: Not Attachable)

Check the pendant rope with referring to the imprints on the rope end.

Dimensions Not Shown In The Figure		Pendant Rope		
Symbols	Boom Length (m)	Length (m)	Rope Diameter (mm)	Imprint
3	3	3	35.5	□ • △ • 35.5 • 3 • C
6	6	5.3	35.5	□ • △ • 35.5 • 5.3 • C
9	9	6	35.5	□ • △ • 35.5 • 6 • C
		9	35.5	□ • △ • 35.5 • 9 • C

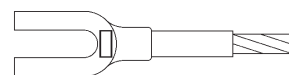

Combination of Boom and Crane Jib (Offset Angle 10° and 30°)

Combination of Boom and Crane Jib (Offset Angle 10° and 30°)																		
Boom Length (m)		12	15	18	21	24	27	30	33	36	39	42	45	48	51	54	57	60
Jib Length (m)	10	×	×	×	×	○	○	○	○	○	○	○	○	○	○	×	×	×
	16	×	×	×	×	○	○	○	○	○	○	○	○	○	○	×	×	×
	22	×	×	×	×	○	○	○	○	○	○	○	○	○	○	×	×	×
	28	×	×	×	×	○	○	○	○	○	○	○	○	○	○	×	×	×

(○ : Attachable × : Not Attachable)

Crane Jib (Offset Angle 10° and 30°)		
Crane Jib Length (m)	Offset Angle	Crane Jib Configurations
10	10°	
	30°	
16	10°	
	30°	
22	10°	
	30°	
28	10°	
	30°	

Check the pendant rope with referring to the imprints on the rope end.

Dimensions Not Shown In The Figure	
Symbols	Jib Length (m)
5	5
6	6

Jib Pendant Rope			
Length (m)	Rope Diameter (mm)	Imprint	
1.6	24	□ · △ · 24 · 1.6 · S	
5.7	24	□ · △ · 24 · 5.7 · S	
8.3	24	□ · △ · 24 · 8.3 · S	
9.6	24	□ · △ · 24 · 9.6 · S	

Working Ranges

■ Main Boom

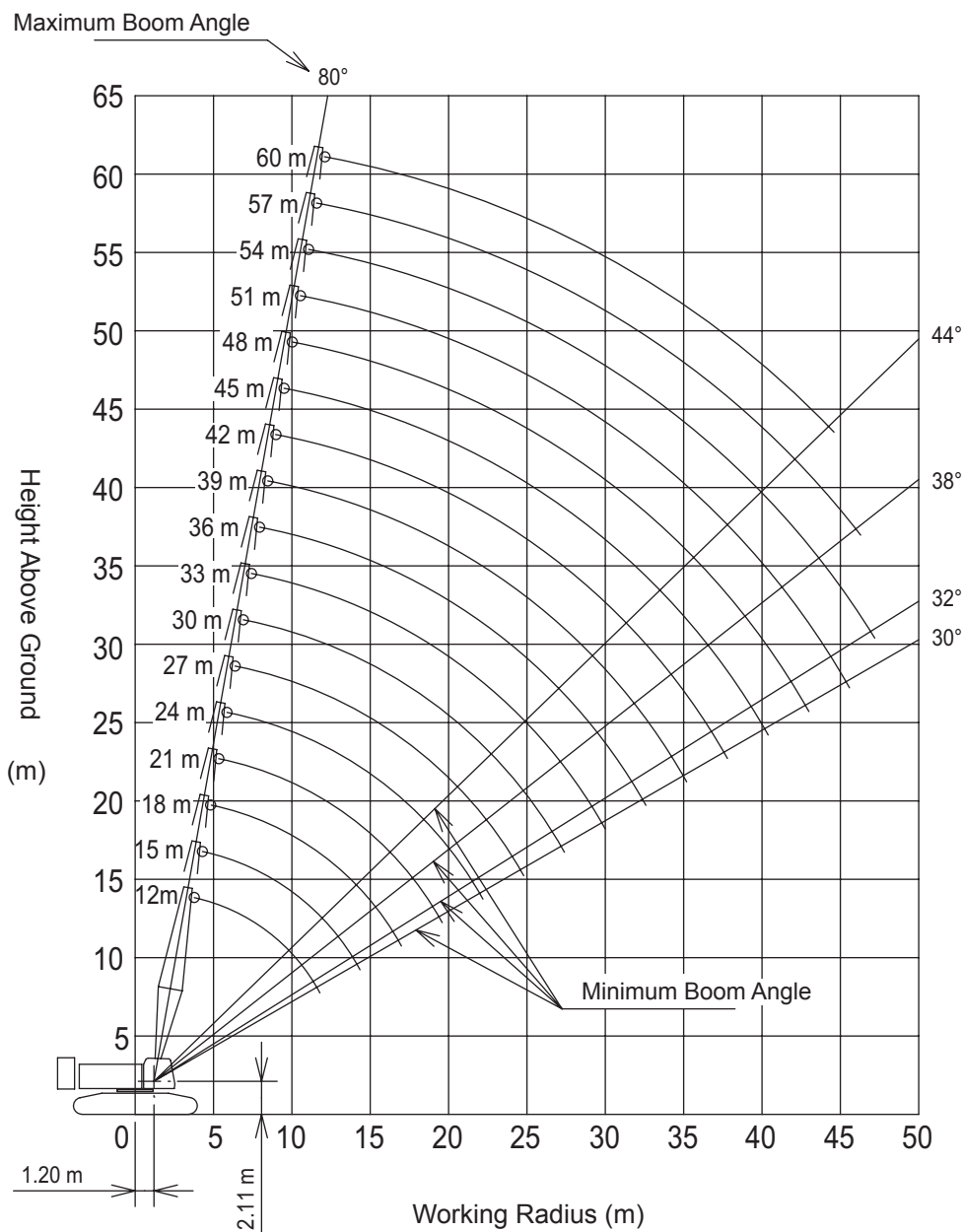
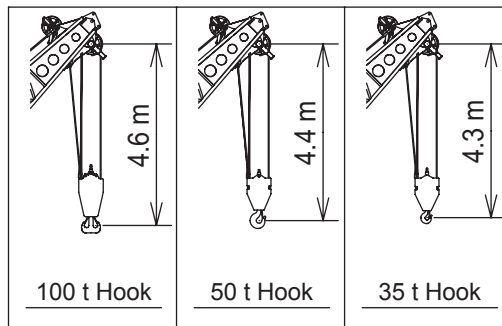

■ Aux. Sheave

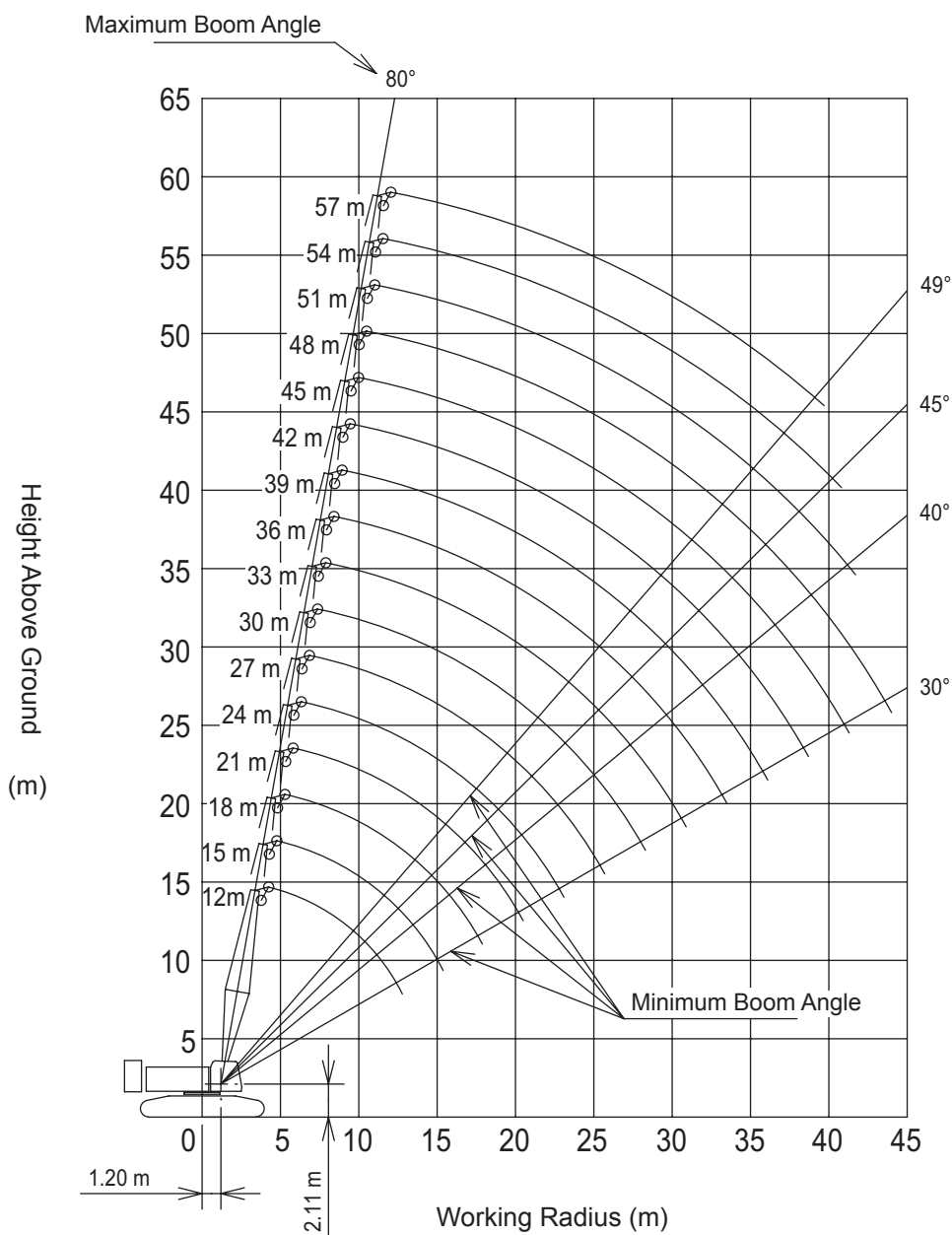
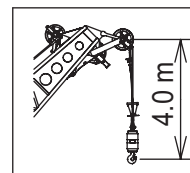

■ Main Boom with Aux. Sheave

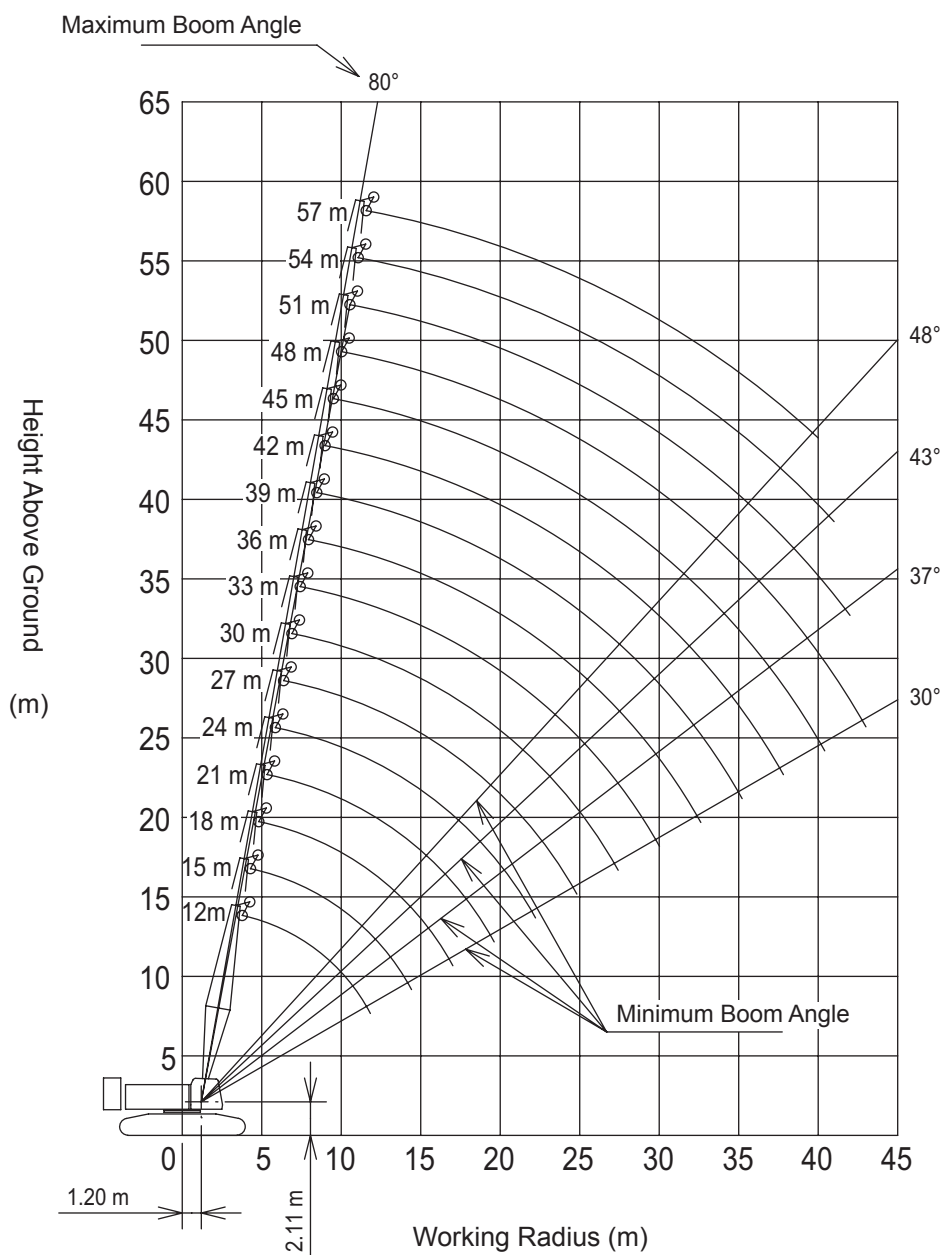
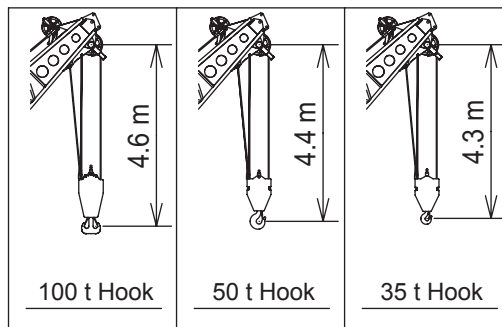

■ Main Boom with 10 m Crane Jib

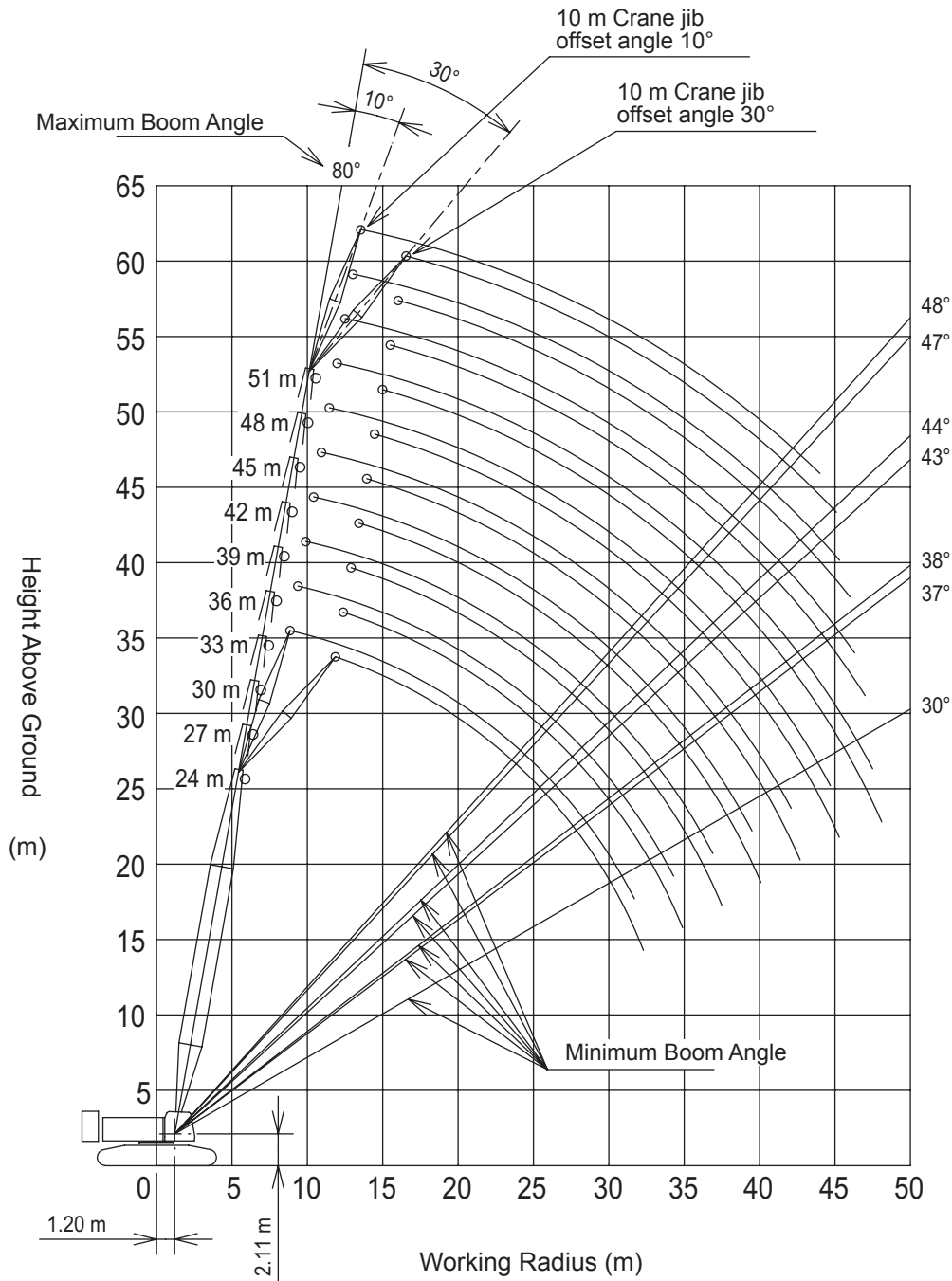
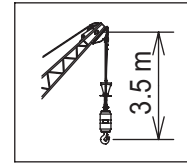

■ Main Boom with 16 m Crane Jib

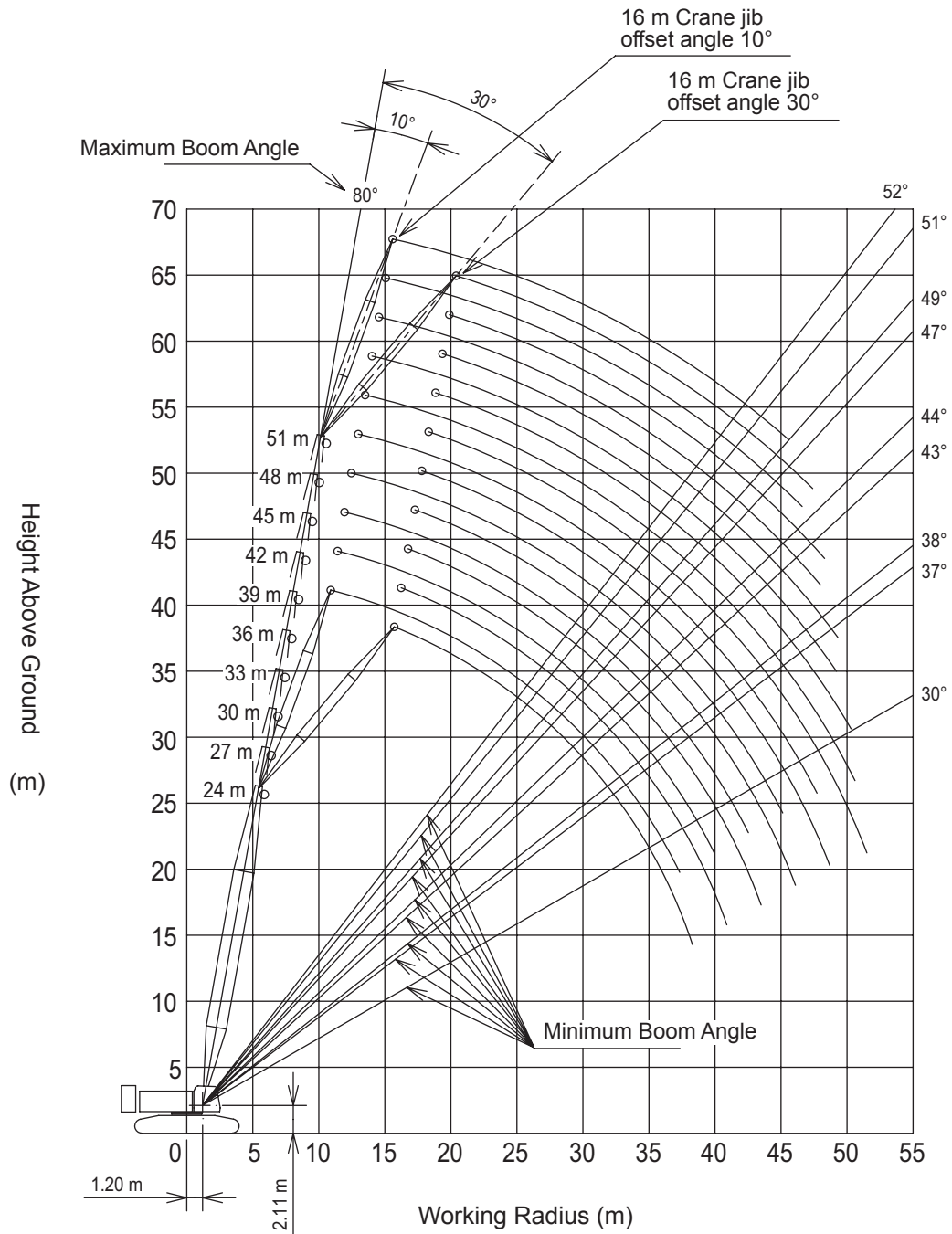
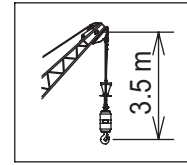

■ Main Boom with 22 m Crane Jib

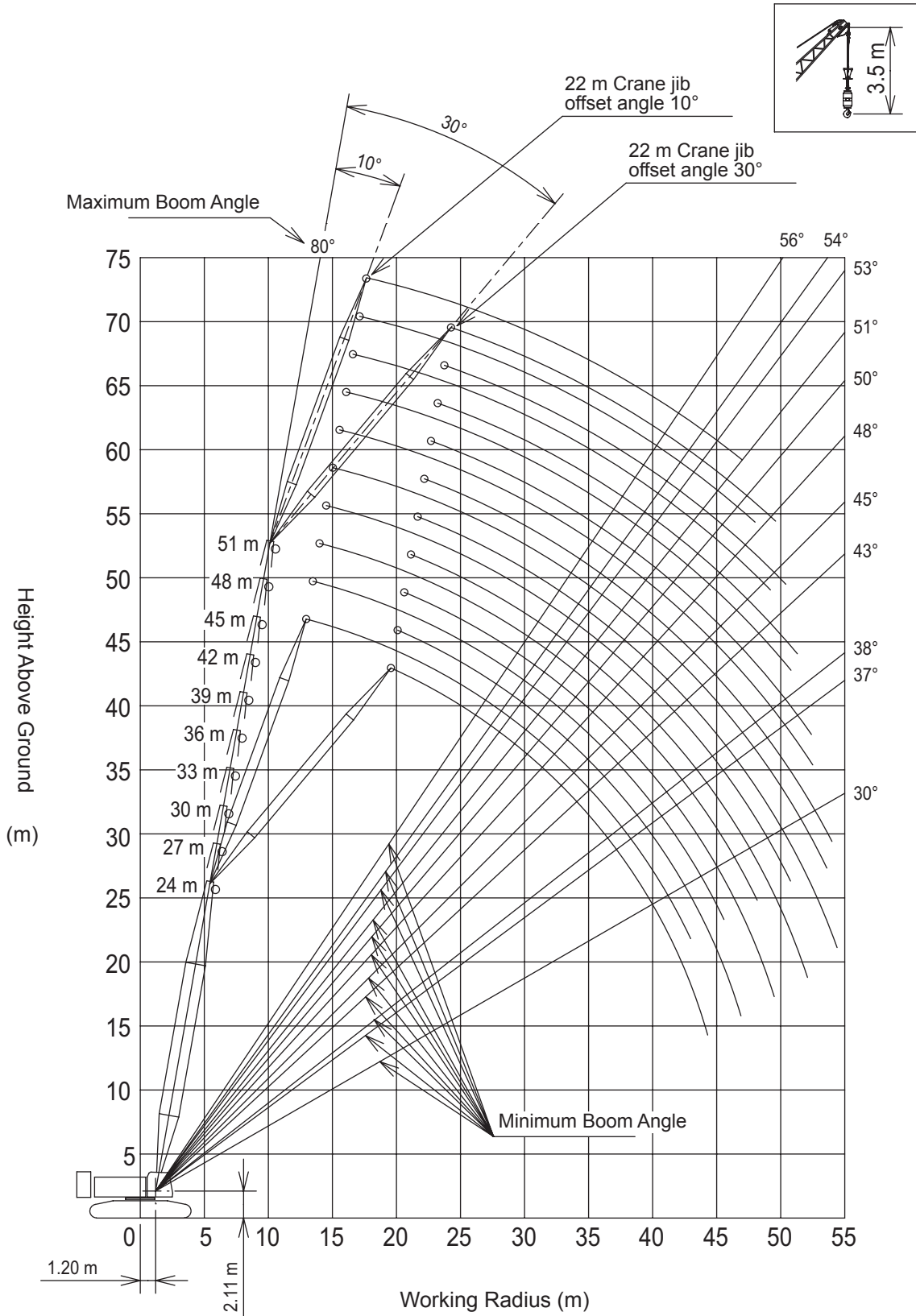

■ Main Boom with 28 m Crane Jib

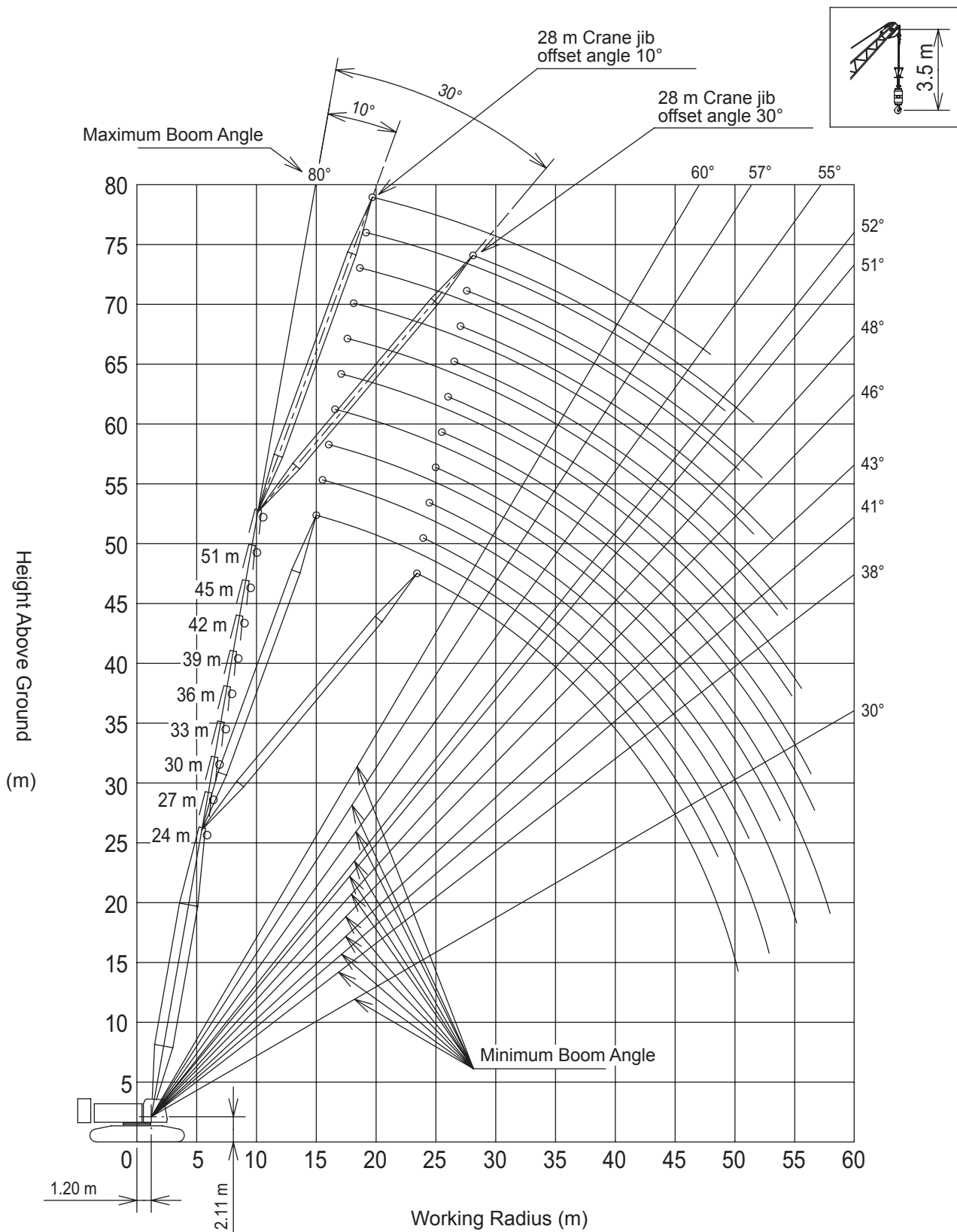

■ Main Boom with 10 m Crane Jib (Offset Angle 10°)

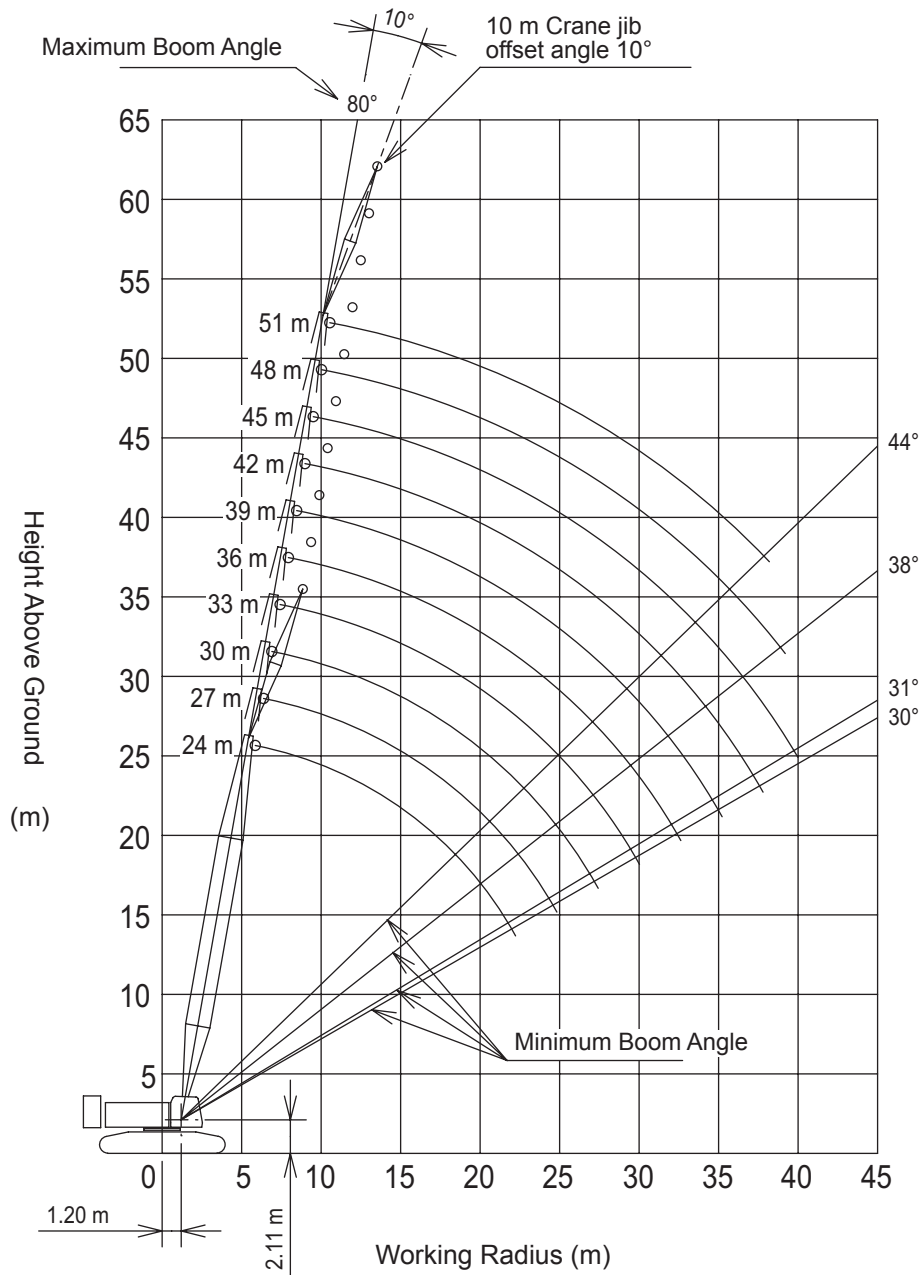
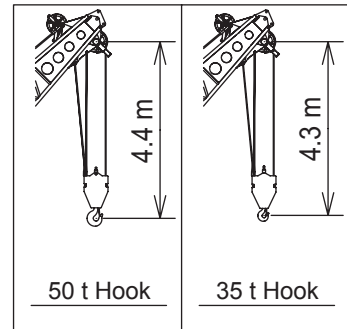

■ Main Boom with 10 m Crane Jib (Offset Angle 30°)

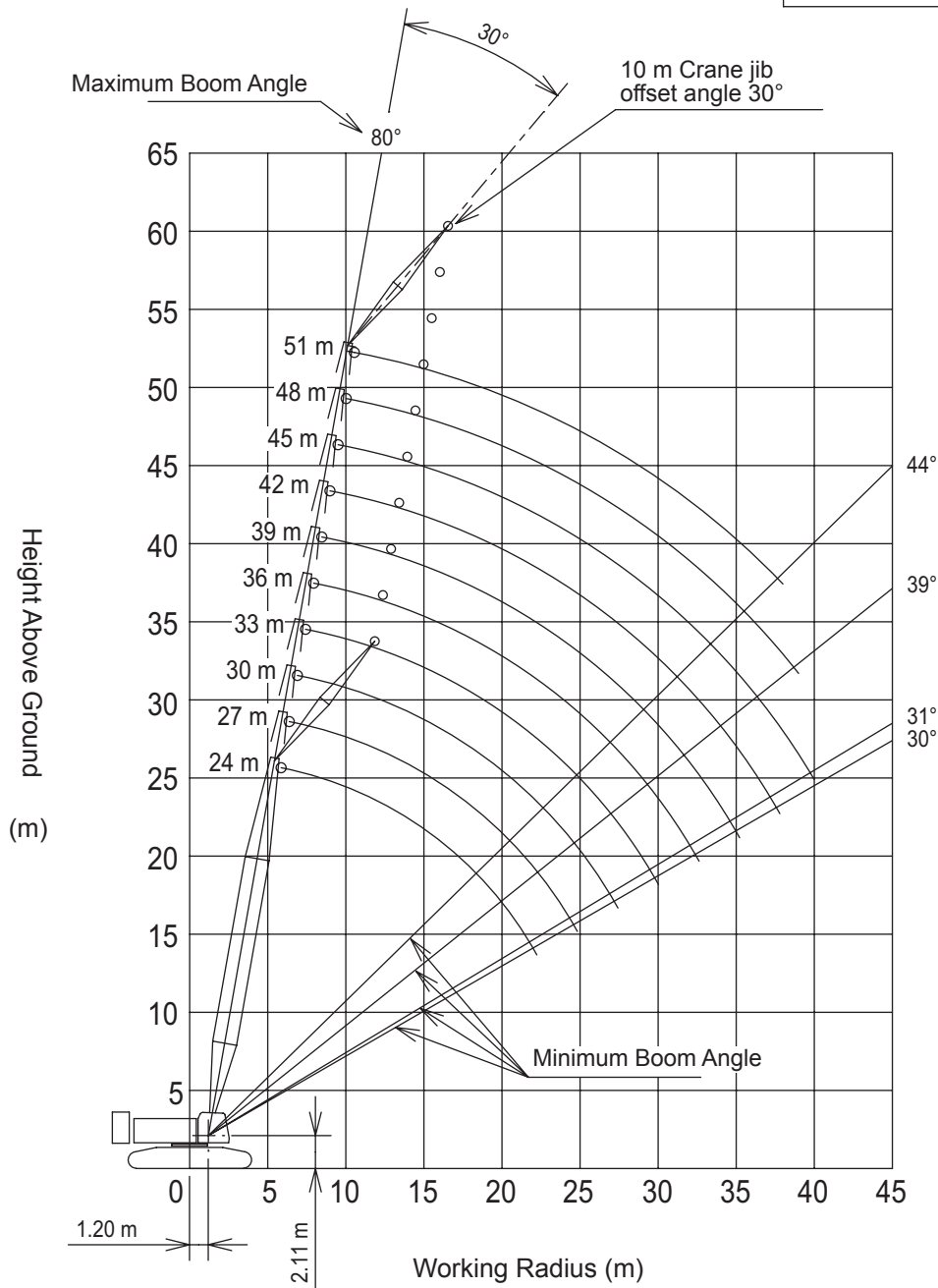
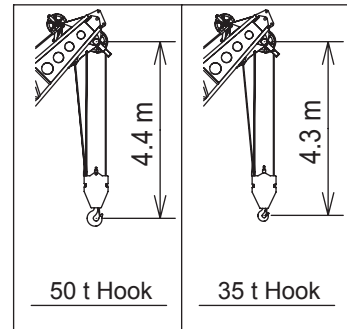

■ Main Boom with 16 m Crane Jib (Offset Angle 10°)

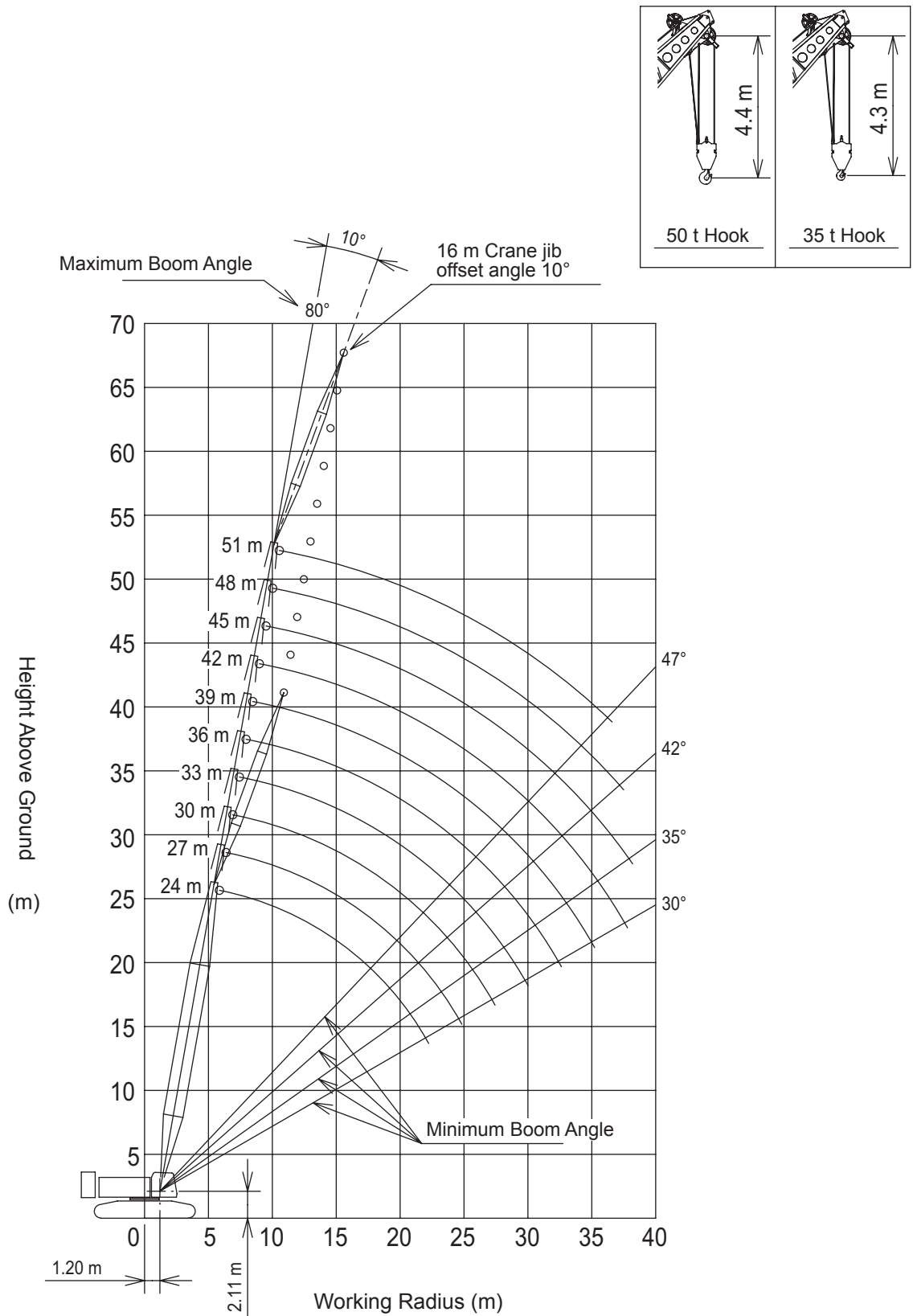

■ Main Boom with 16 m Crane Jib (Offset Angle 30°)

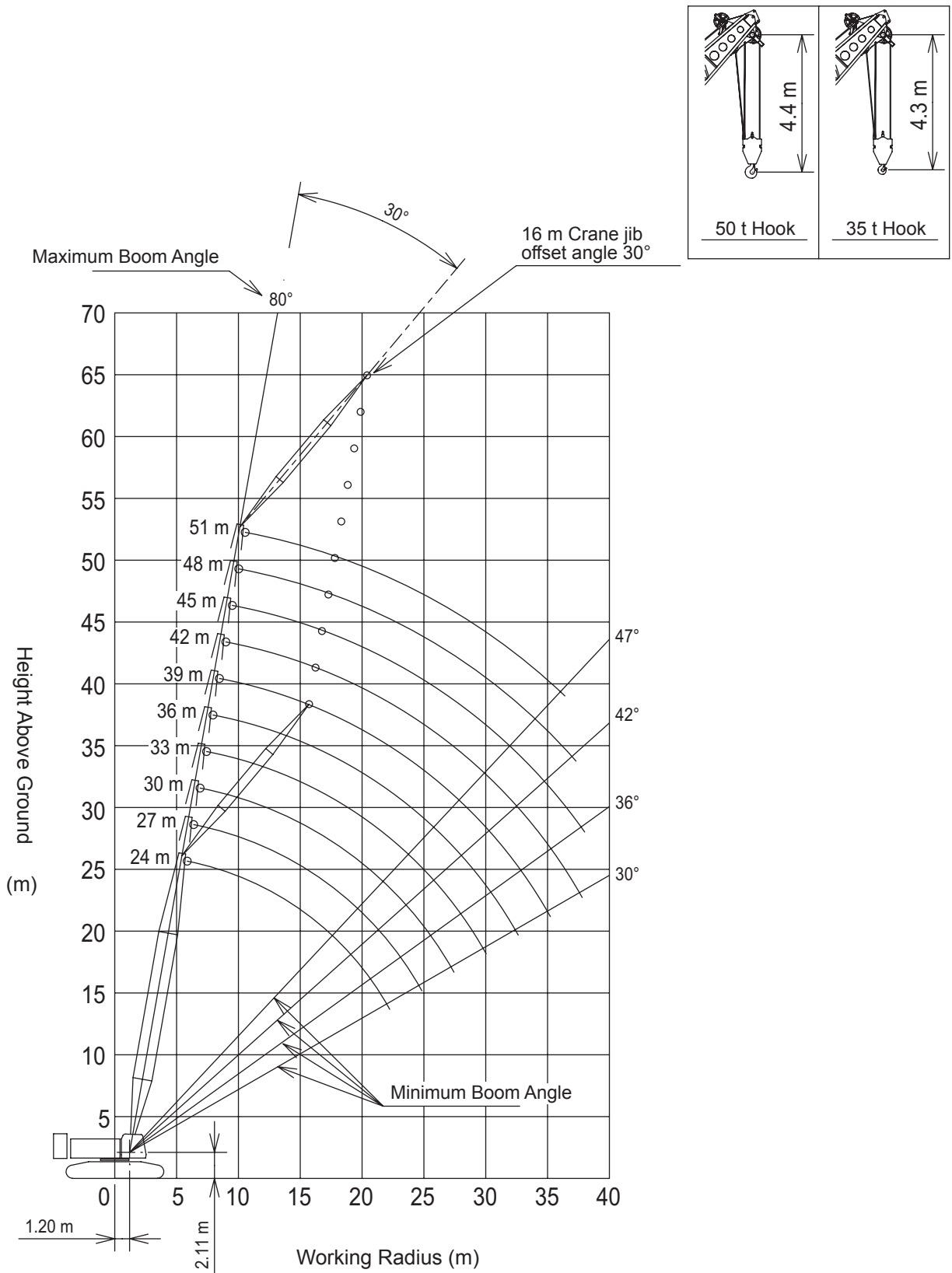

■ Main Boom with 22 m Crane Jib (Offset Angle 10°)

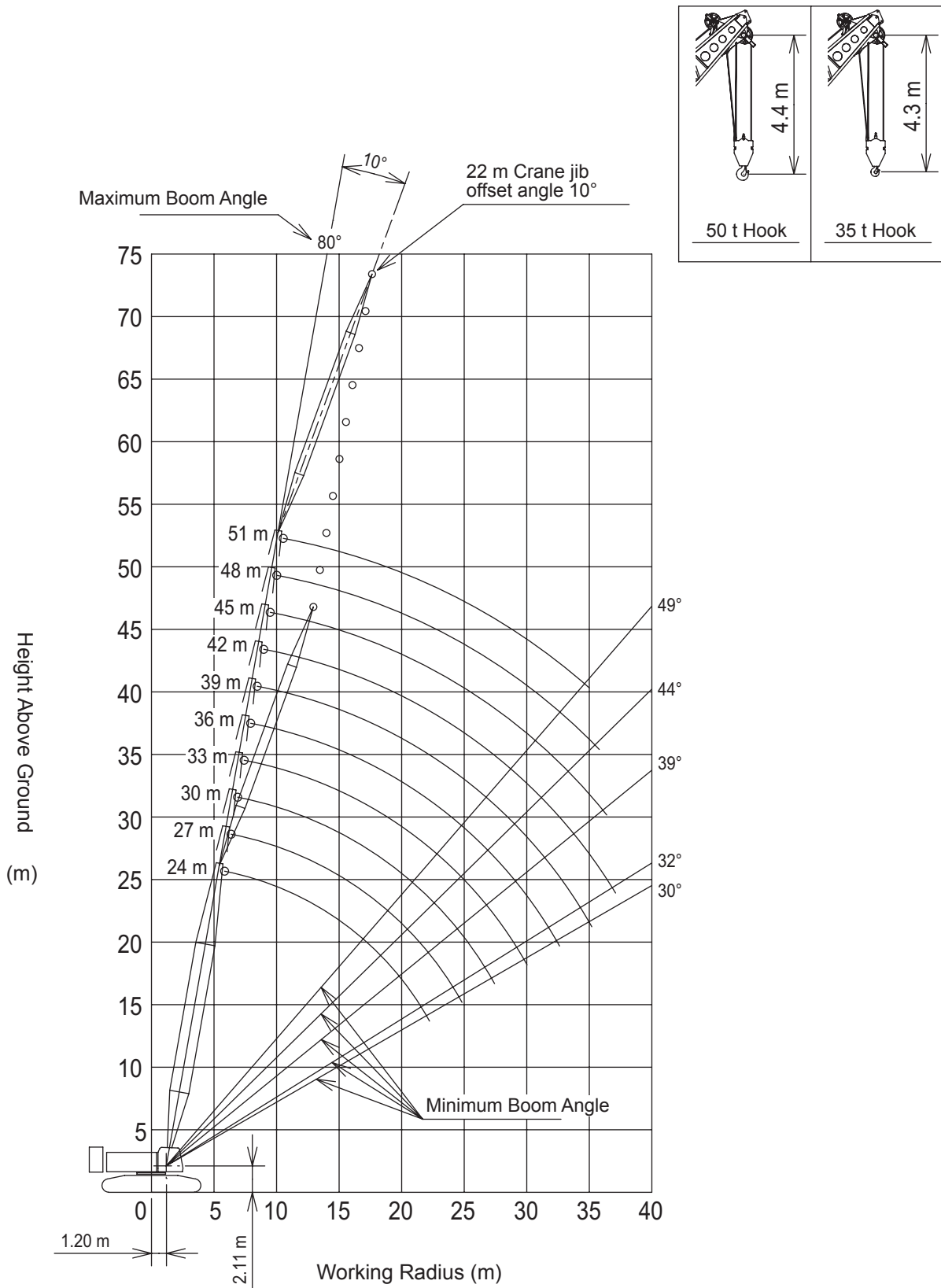

■ Main Boom with 22 m Crane Jib (Offset Angle 30°)

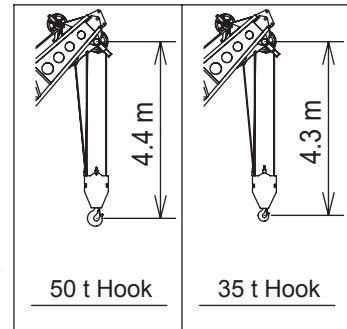
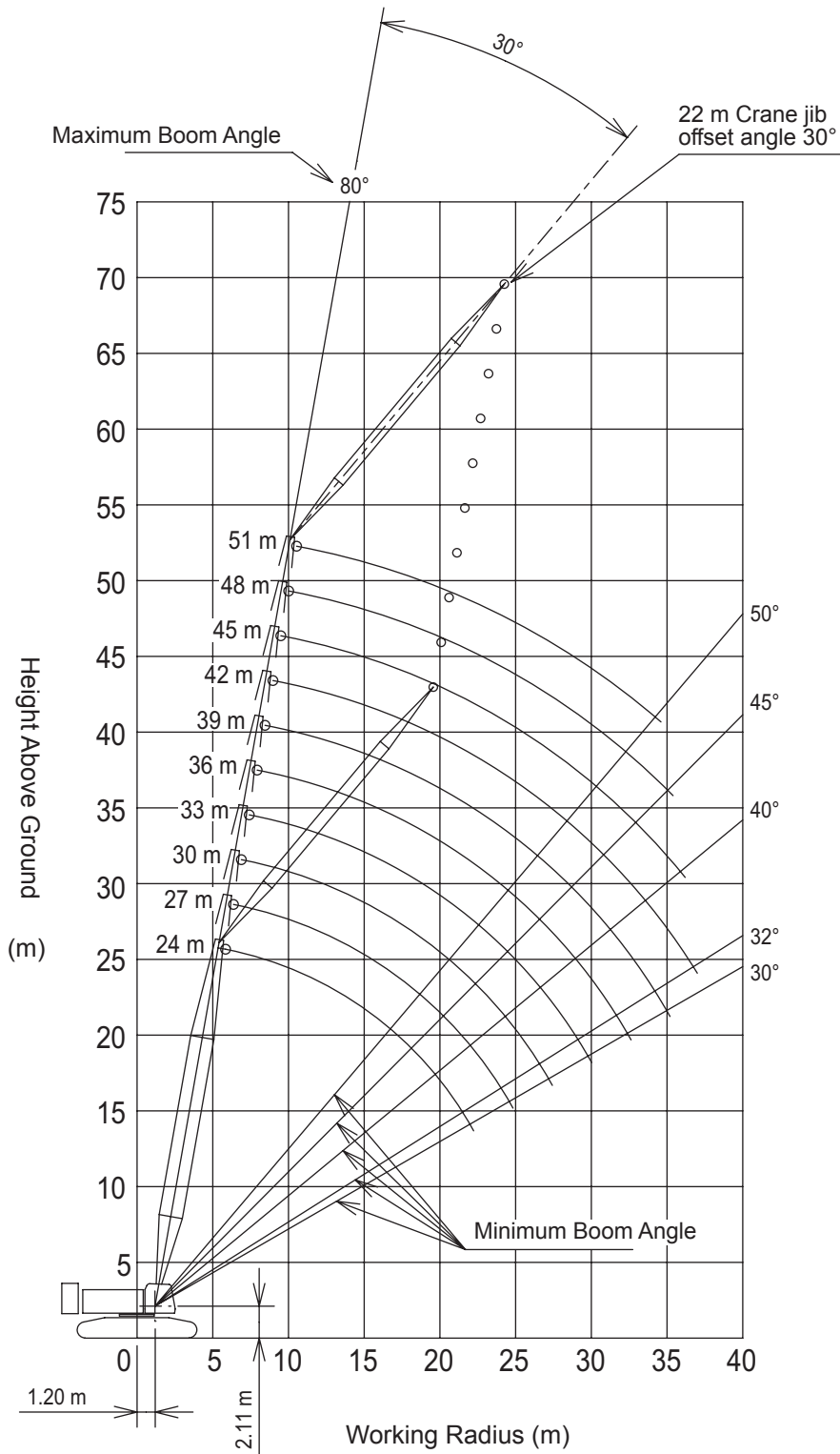

■ Main Boom with 28 m Crane Jib (Offset Angle 10°)

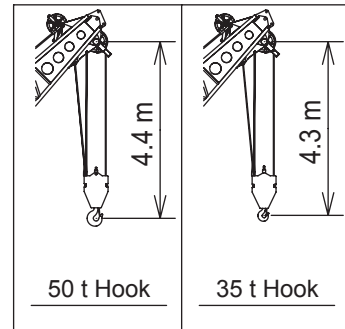
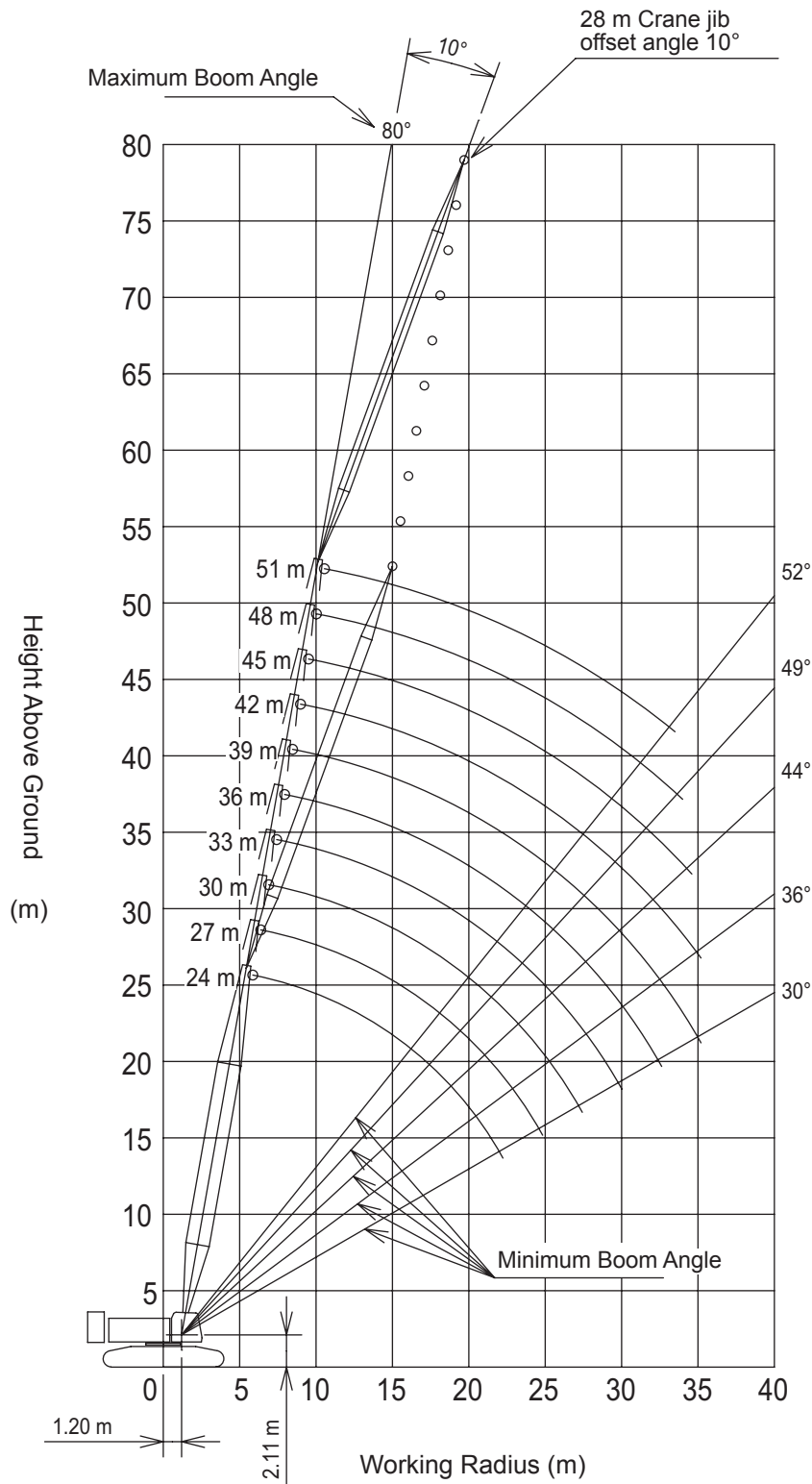

■ Main Boom with 28 m Crane Jib (Offset Angle 30°)

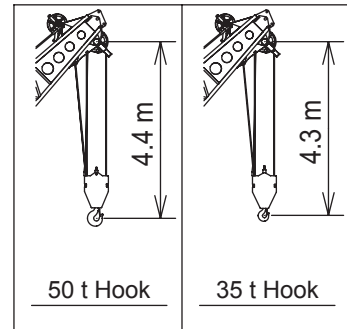
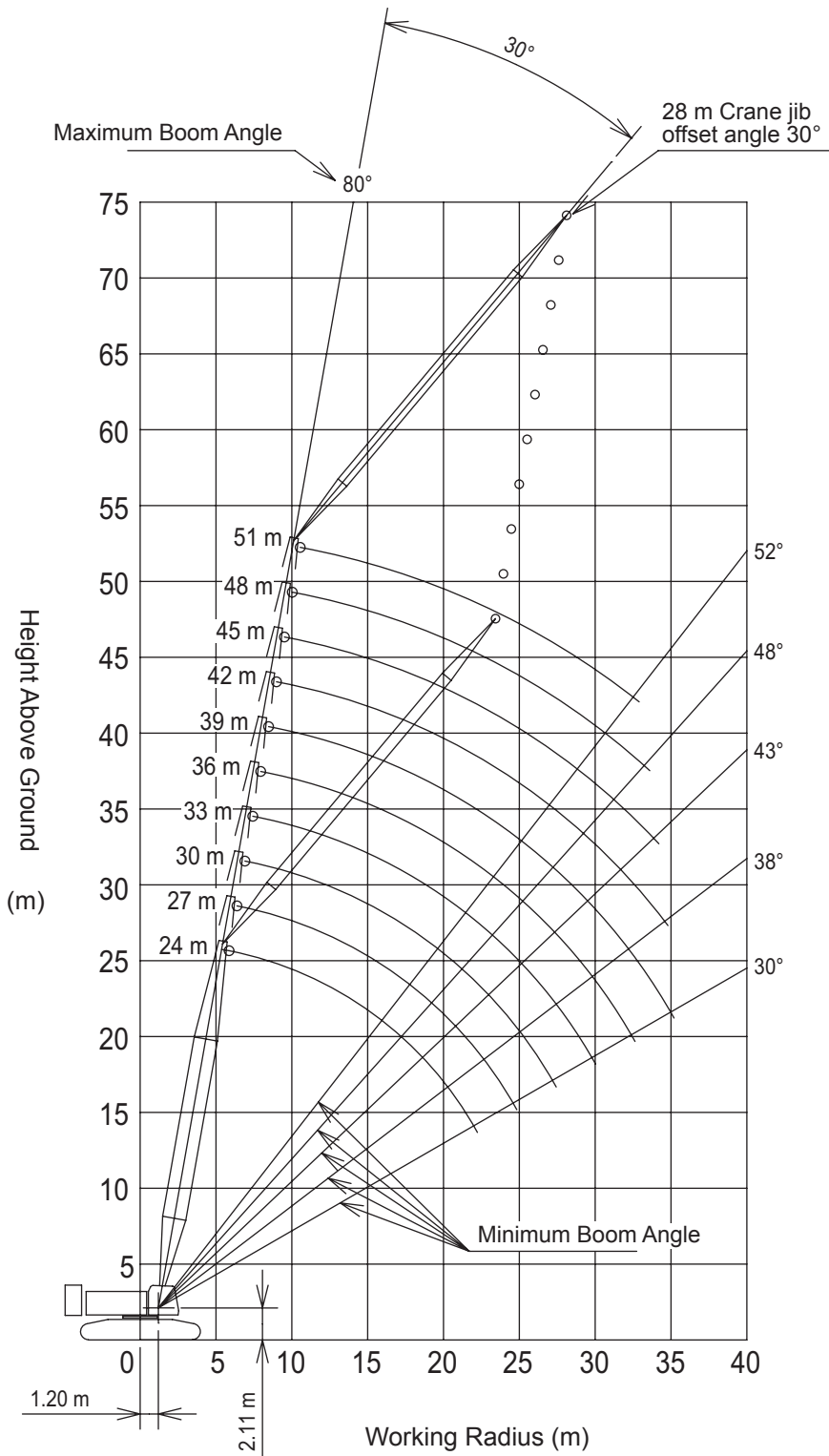

Gross Rated Load Table

Main Boom



Unit: ton loads /working radius

Working Radius(m)	Boom Length (m)										Working Radius(m)	
	12	15	18	21	24	27	30	33	36	39		
3.8	100.00											3.8
4.0	94.95											4.0
4.5	84.40	84.40										4.5
5.0	75.95	75.95	75.95									5.0
5.5	69.05	69.05	68.80	65.70 /5.6								5.5
6.0	63.30	63.30	62.85	60.75	57.25 /6.1	49.85 /6.7						6.0
7.0	54.10	54.10	53.00	51.15	49.30	47.60	44.65 /7.2	39.65 /7.8				7.0
8.0	44.90	44.90	44.75	44.05	42.60	41.25	39.95	38.65	36.00 /8.3	32.95 /8.8		8.0
9.0	38.10	38.05	37.90	37.85	37.45	36.35	35.30	34.15	33.15	32.20		9.0
10.0	33.00	32.90	32.75	32.70	32.60	32.40	31.55	30.55	29.70	28.90		10.0
12.0	26.50 /11.8	25.80	25.60	25.55	25.40	25.35	25.15	25.00	24.40	23.80		12.0
14.0		21.10	20.90	20.80	20.65	20.60	20.40	20.25	20.00	20.00		14.0
16.0		20.30 /14.4	17.55	17.45	17.25	17.20	17.00	16.85	16.60	16.55		16.0
18.0			16.20 /17.0	14.90	14.75	14.65	14.45	14.30	14.05	14.00		18.0
20.0				13.35 /19.6	12.80	12.70	12.50	12.30	12.05	12.05		20.0
22.0					11.25	11.10	10.90	10.70	10.50	10.45		22.0
24.0					11.10 /22.2	9.85	9.65	9.45	9.20	9.15		24.0
26.0						9.40 /24.8	8.60	8.35	8.15	8.10		26.0
28.0							7.95 /27.4	7.45	7.25	7.15		28.0
30.0								6.70	6.45	6.40		30.0
32.0									5.80	5.75		32.0
34.0									5.60 /32.6	5.15		34.0
36.0										4.85 /35.2		36.0

Unit: ton loads /working radius

Working Radius(m)	Boom Length (m)								Working Radius(m)
	42	45	48	51	54	57	60		
9.0	29.90 /9.4	27.60 /9.9							9.0
10.0	28.05	27.35	25.35 /10.5	22.45 /11.1	19.35 /11.6				10.0
12.0	23.15	22.60	22.05	21.35	19.15	18.05 /12.2	14.55 /12.7		12.0
14.0	19.50	19.05	18.65	18.05	17.60	17.15	14.10		14.0
16.0	16.35	16.20	16.00	15.45	15.10	14.70	13.40		16.0
18.0	13.80	13.65	13.50	13.40	13.05	12.75	12.35		18.0
20.0	11.80	11.65	11.50	11.40	11.25	11.15	10.75		20.0
22.0	10.20	10.05	9.95	9.80	9.65	9.55	9.30		22.0
24.0	8.90	8.75	8.65	8.50	8.35	8.20	8.00		24.0
26.0	7.85	7.70	7.55	7.40	7.25	7.15	6.90		26.0
28.0	6.95	6.80	6.65	6.50	6.35	6.20	6.00		28.0
30.0	6.15	6.00	5.85	5.70	5.55	5.40	5.20		30.0
32.0	5.50	5.35	5.20	5.05	4.90	4.75	4.50		32.0
34.0	4.90	4.75	4.60	4.45	4.30	4.15	3.90		34.0
36.0	4.40	4.25	4.10	3.90	3.75	3.60	3.40		36.0
38.0	4.00 /37.8	3.80	3.65	3.45	3.30	3.15	2.90		38.0
40.0		3.40	3.25	3.05	2.90	2.75	2.50		40.0
42.0		3.30 /40.4	2.85	2.65	2.50	2.35	2.15		42.0
44.0			2.70 /43.0	2.35	2.20	2.05	1.80		44.0
46.0				2.15 /45.3	1.90	1.75	1.70 /44.6		46.0
48.0					1.70 /47.2	1.70 /46.3			48.0

- The rated loads are determined according to EN13000 rating on the condition that the machine is stationed on firm, level ground.
- The figures surrounded by bold lines are based on factors other than those which would cause a tipping condition.
- To calculate the maximum load that can actually be lifted, deduct weight of all lifting accessories, such as boom hook and jib hook, from figures shown above.
- Working radius is the horizontal distance from the slewing center to the center of gravity of a lifted load.
- The counterweight is 49.5 ton. (Upper weight 37.5 ton + Lower weight 12.0 ton)
- Hook weights are shown in the table below.

Hook Capacity (t)	Hook Weight (t)	Maximum Rated Loads (t)							
		8 falls	7 falls	6 falls	5 falls	4 falls	3 falls	2 falls	1 fall
100	1.20	100	84	72	60	48	-	-	-
50	1.17	-	-	-	50	48	36	24	-
35	0.90	-	-	-	-	-	35	24	-
12	0.51	-	-	-	-	-	-	-	12

■ Aux. Sheave



Unit: ton loads /working radius

Working Radius(m)	Boom Length (m)										Working Radius(m)	
	12	15	18	21	24	27	30	33	36	39		
4.6	12.00											4.6
5.0	12.00	12.00 /5.3										5.0
5.5	12.00	12.00	12.00 /5.8									5.5
6.0	12.00	12.00	12.00	12.00 /6.3	12.00 /6.9							6.0
7.0	12.00	12.00	12.00	12.00	12.00	12.00 /7.4						7.0
8.0	12.00	12.00	12.00	12.00	12.00	12.00	12.00	12.00 /8.5				8.0
9.0	12.00	12.00	12.00	12.00	12.00	12.00	12.00	12.00	12.00 /9.1	12.00 /9.6		9.0
10.0	12.00	12.00	12.00	12.00	12.00	12.00	12.00	12.00	12.00	12.00	12.00	10.0
12.0	12.00	12.00	12.00	12.00	12.00	12.00	12.00	12.00	12.00	12.00	12.00	12.0
14.0	12.00 /13.1	12.00	12.00	12.00	12.00	12.00	12.00	12.00	12.00	12.00	12.00	14.0
16.0		12.00 /15.7	12.00	12.00	12.00	12.00	12.00	12.00	12.00	12.00	12.00	16.0
18.0			12.00	12.00	12.00	12.00	12.00	12.00	12.00	12.00	12.00	18.0
20.0			12.00 /18.2	12.00	12.00	12.00	12.00	12.00	12.00	11.80	11.75	20.0
22.0				12.00 /20.8	11.00	10.85	10.65	10.45	10.20	10.15		22.0
24.0					10.10 /23.4	9.60	9.35	9.15	8.90	8.85		24.0
26.0						8.50	8.30	8.10	7.85	7.80		26.0
28.0							7.40	7.20	6.95	6.85		28.0
30.0							7.20 /28.6	6.40	6.15	6.10		30.0
32.0								6.00 /31.2	5.50	5.40		32.0
34.0									5.00 /33.8	4.85		34.0
36.0										4.30		36.0
38.0										4.25 /36.4		38.0

Unit: ton loads /working radius

Working Radius(m)	Boom Length (m)						Working Radius(m)
	42	45	48	51	54	57	
10.0	12.00 /10.2	12.00 /10.7	12.00 /11.3	12.00 /11.8			10.0
12.0	12.00	12.00	12.00	12.00	12.00 /12.4	12.00 /12.9	12.0
14.0	12.00	12.00	12.00	12.00	12.00	12.00	14.0
16.0	12.00	12.00	12.00	12.00	12.00	12.00	16.0
18.0	12.00	12.00	12.00	12.00	12.00	12.00	18.0
20.0	11.55	11.35	11.25	11.10	10.80	10.45	20.0
22.0	9.90	9.75	9.60	9.50	9.35	9.10	22.0
24.0	8.60	8.45	8.30	8.20	8.05	7.90	24.0
26.0	7.55	7.35	7.20	7.10	6.95	6.80	26.0
28.0	6.60	6.45	6.30	6.15	6.00	5.85	28.0
30.0	5.85	5.65	5.50	5.40	5.20	5.05	30.0
32.0	5.15	5.00	4.85	4.70	4.55	4.40	32.0
34.0	4.55	4.40	4.25	4.10	3.95	3.80	34.0
36.0	4.05	3.90	3.75	3.60	3.40	3.25	36.0
38.0	3.60	3.45	3.25	3.10	2.95	2.80	38.0
40.0	3.40 /39.0	3.05	2.85	2.70	2.55	2.35	40.0
42.0		2.75 /41.6	2.50	2.35	2.20 /41.7	2.20 /40.8	42.0
44.0			2.20	2.20 /42.8			44.0

1. The rated loads are determined according to EN13000 rating on the condition that the machine is stationed on firm, level ground.
2. The figures surrounded by bold lines are based on factors other than those which would cause a tipping condition.
3. To calculate the maximum load that can actually be lifted, deduct weight of all lifting accessories, such as boom hook and jib hook, from figures shown above.
4. Working radius is the horizontal distance from the slewing center to the center of gravity of a lifted load.
5. The counterweight is 49.5 ton. (Upper weight 37.5 ton + Lower weight 12.0 ton)
6. Hook weights are shown in the table below.

Hook Capacity (t)	Hook Weight (t)
100	1.20
50	1.17
35	0.90
12	0.51

■ Main Boom with Aux. Sheave



Unit: ton loads /working radius

Working Radius(m)	Boom Length (m)										Working Radius(m)
	12	15	18	21	24	27	30	33	36	39	
3.8	97.60										3.8
4.0	94.95										4.0
4.5	84.40	84.40									4.5
5.0	75.95	75.95	75.95								5.0
5.5	69.05	69.05	68.80	65.10 /5.6							5.5
6.0	63.30	63.30	62.80	60.20	56.60 /6.1	49.20 /6.7					6.0
7.0	54.10	54.10	52.40	50.50	48.70	47.00	44.00 /7.2	39.00 /7.8			7.0
8.0	44.50	44.40	44.30	43.50	42.00	40.70	39.40	38.00	35.40 /8.3	32.30 /8.8	8.0
9.0	37.70	37.60	37.50	37.40	36.80	35.70	34.70	33.50	32.50	31.60	9.0
10.0	32.60	32.50	32.30	32.30	32.10	31.80	30.90	29.90	29.00	28.20	10.0
12.0	26.10 /11.8	25.40	25.20	25.10	25.00	24.90	24.70	24.50	23.80	23.20	12.0
14.0		20.70	20.50	20.40	20.20	20.10	19.90	19.80	19.50	19.40	14.0
16.0		19.90 /14.4	17.10	17.00	16.80	16.70	16.50	16.40	16.10	16.10	16.0
18.0			15.80 /17.0	14.50	14.30	14.20	14.00	13.80	13.60	13.50	18.0
20.0				12.90 /19.6	12.40	12.30	12.00	11.80	11.60	11.60	20.0
22.0					10.80	10.70	10.50	10.30	10.00	10.00	22.0
24.0					10.70 /22.2	9.40	9.20	9.00	8.70	8.70	24.0
26.0						9.00 /24.8	8.20	7.90	7.70	7.60	26.0
28.0							7.50 /27.4	7.00	6.80	6.70	28.0
30.0								6.30	6.00	5.90	30.0
32.0									5.40	5.30	32.0
34.0									5.20 /32.6	4.70	34.0
36.0										4.40 /35.2	36.0

Unit: ton loads /working radius

Working Radius(m)	Boom Length (m)						Working Radius(m)
	42	45	48	51	54	57	
9.0	29.20 /9.4	26.90 /9.9					9.0
10.0	27.40	26.70	24.70 /10.5	21.40 /11.1	18.30 /11.6		10.0
12.0	22.50	21.90	21.40	20.70	18.10	17.00 /12.2	12.0
14.0	18.90	18.40	17.90	17.30	16.90	16.30	14.0
16.0	15.80	15.70	15.30	14.80	14.40	14.00	16.0
18.0	13.30	13.10	13.00	12.70	12.40	12.00	18.0
20.0	11.30	11.10	11.00	10.90	10.70	10.40	20.0
22.0	9.70	9.60	9.40	9.30	9.10	9.00	22.0
24.0	8.40	8.30	8.10	8.00	7.80	7.70	24.0
26.0	7.40	7.20	7.00	6.90	6.70	6.60	26.0
28.0	6.50	6.30	6.10	6.00	5.80	5.70	28.0
30.0	5.70	5.50	5.40	5.20	5.00	4.90	30.0
32.0	5.00	4.80	4.70	4.50	4.40	4.20	32.0
34.0	4.40	4.30	4.10	3.90	3.80	3.60	34.0
36.0	3.90	3.80	3.60	3.40	3.20	3.10	36.0
38.0	3.50 /37.8	3.30	3.20	3.00	2.80	2.60	38.0
40.0		2.90	2.80	2.50	2.40	2.20	40.0
42.0		2.90 /40.4	2.40	2.20	2.20 /41.0		42.0
43.0			2.20				43.0

1. The rated loads are determined according to EN13000 rating on the condition that the machine is stationed on firm, level ground.
2. The figures surrounded by bold lines are based on factors other than those which would cause a tipping condition.
3. To calculate the maximum load that can actually be lifted, deduct weight of all lifting accessories, such as boom hook and jib hook, from figures shown above.
4. Working radius is the horizontal distance from the slewing center to the center of gravity of a lifted load.
5. The counterweight is 49.5 ton. (Upper weight 37.5 ton + Lower weight 12.0 ton)
6. Hook weights are shown in the table below.

Hook Capacity (t)	Hook Weight (t)	Maximum Rated Loads (t)							
		8 falls	7 falls	6 falls	5 falls	4 falls	3 falls	2 falls	1 fall
100	1.20	100	84	72	60	48	-	-	-
50	1.17	-	-	-	50	48	36	24	-
35	0.90	-	-	-	-	-	35	24	-
12	0.51	-	-	-	-	-	-	-	12

Crane Jib



Unit: ton (loads/working radius)

Boom Length (m)	24.0								Boom Length (m)
Jib Length (m)	10.0		16.0		22.0		28.0		Jib Length (m)
Offset Angle (deg) Radius (m)	10.0	30.0	10.0	30.0	10.0	30.0	10.0	30.0	Offset Angle (deg) Radius (m)
9.5	12.00								9.5
10.0	12.00		12.00 /11.6						10.0
12.0	12.00	11.25 /12.5	12.00		8.80 /13.7				12.0
14.0	12.00	10.75	12.00		8.80		5.50 /15.8		14.0
16.0	12.00	10.10	12.00	8.00 /16.4	8.80		5.50		16.0
18.0	12.00	9.60	12.00	7.60	8.80		5.50		18.0
20.0	12.00	9.15	12.00	7.20	8.80	6.00 /20.3	5.50		20.0
22.0	11.45	8.75	11.75	6.85	8.80	5.75	5.50		22.0
24.0	10.15	8.40	10.40	6.50	8.45	5.45	5.50	3.40 /24.2	24.0
26.0	9.05	8.10	9.30	6.25	8.15	5.20	5.50	3.40	26.0
28.0	8.10	7.85	8.35	6.00	7.80	4.95	5.45	3.40	28.0
30.0	7.35	7.45	7.60	5.75	7.50	4.75	5.20	3.40	30.0
32.0	6.70 /31.9	6.70	6.90	5.55	7.05	4.55	5.00	3.40	32.0
34.0		6.55 /32.5	6.30	5.40	6.45	4.35	4.80	3.40	34.0
36.0			5.75	5.30	5.90	4.20	4.65	3.40	36.0
38.0			5.40 /37.6	5.20	5.45	4.10	4.40	3.40	38.0
40.0				5.20 /38.5	5.00	4.00	4.25	3.30	40.0
42.0					4.65	3.90	4.15	3.20	42.0
44.0					4.45 /43.2	3.85	4.00	3.10	44.0
46.0						3.85 /44.5	3.85	3.00	46.0
48.0							3.75	2.95	48.0
50.0							3.65 /48.9	2.90	50.0
52.0							2.90 /50.5		52.0

Unit: ton (loads/working radius)

Boom Length (m)	27.0								Boom Length (m)
Jib Length (m)	10.0		16.0		22.0		28.0		Jib Length (m)
Offset Angle (deg) Radius (m)	10.0	30.0	10.0	30.0	10.0	30.0	10.0	30.0	Offset Angle (deg) Radius (m)
10.0	12.00								10.0
12.0	12.00	11.25 /13.0	12.00 /12.1						12.0
14.0	12.00	10.90	12.00		8.80 /14.2				14.0
16.0	12.00	10.35	12.00	7.95 /16.9	8.80		5.50 /16.3		16.0
18.0	12.00	9.80	12.00	7.75	8.80		5.50		18.0
20.0	12.00	9.35	12.00	7.35	8.80	6.00 /20.8	5.50		20.0
22.0	11.30	8.95	11.60	7.00	8.80	5.85	5.50		22.0
24.0	10.00	8.60	10.25	6.65	8.65	5.55	5.50	3.40 /24.7	24.0
26.0	8.90	8.30	9.15	6.40	8.30	5.30	5.50	3.40	26.0
28.0	7.95	8.05	8.25	6.15	8.00	5.05	5.50	3.40	28.0
30.0	7.20	7.30	7.45	5.90	7.60	4.85	5.40	3.40	30.0
32.0	6.50	6.60	6.75	5.70	6.90	4.65	5.15	3.40	32.0
34.0	5.90	5.95	6.15	5.55	6.30	4.50	4.95	3.40	34.0
36.0	5.75 /34.5	5.65 /35.1	5.60	5.40	5.75	4.35	4.75	3.40	36.0
38.0			5.15	5.25	5.30	4.20	4.55	3.40	38.0
40.0			4.70	4.80	4.85	4.10	4.45	3.40	40.0
42.0			4.70 /40.2	4.55 /41.1	4.45	4.00	4.25	3.25	42.0
44.0					4.15	3.90	4.10	3.15	44.0
46.0					3.85 /45.8	3.85	3.90	3.10	46.0
48.0						3.75 /47.1	3.60	3.00	48.0
50.0							3.35	2.95	50.0
52.0							3.20 /51.5	2.90	52.0
54.0							2.90 /53.1		54.0

- The rated loads are determined according to EN13000 rating on the condition that the machine is stationed on firm, level ground.
- The figures surrounded by bold lines are based on factors other than those which would cause a tipping condition.
- To calculate the maximum load that can actually be lifted, deduct weight of all lifting accessories, such as boom hook and jib hook, from figures shown above.
- Working radius is the horizontal distance from the slewing center to the center of gravity of a lifted load.
- The offset angles shown are of jib boom offset angle against the main boom, under load.
- The counterweight is 49.5 ton. (Upper weight 37.5 ton + Lower weight 12.0 ton)
- Hook weight are shown in the table below.

Hook Capacity (t)	Hook Weight (t)
100	1.20
50	1.17
35	0.90
12	0.51

■ Crane Jib



Unit: ton loads/working radius

Boom Length (m)	30								Boom Length (m)
Jib Length (m)	10		16		22		28		Jib Length (m)
Offset Angle (deg) Radius (m)	10	30	10	30	10	30	10	30	Offset Angle (deg) Radius (m)
10.0	12.00 /10.6								10.0
12.0	12.00	11.20 /13.6	12.00 /12.7						12.0
14.0	12.00	11.05	12.00		8.80 /14.8				14.0
16.0	12.00	10.50	12.00	7.95 /17.5	8.80		5.50 /16.9		16.0
18.0	12.00	10.00	12.00	7.85	8.80		5.50		18.0
20.0	12.00	9.55	12.00	7.45	8.80	6.00 /21.4	5.50		20.0
22.0	11.10	9.20	11.40	7.10	8.80	5.90	5.50		22.0
24.0	9.75	8.85	10.05	6.80	8.75	5.60	5.50	3.40 /25.3	24.0
26.0	8.65	8.55	8.95	6.55	8.45	5.35	5.50	3.40	26.0
28.0	7.75	7.95	8.00	6.30	8.20	5.15	5.50	3.40	28.0
30.0	6.95	7.15	7.20	6.05	7.40	4.95	5.50	3.40	30.0
32.0	6.30	6.40	6.50	5.85	6.70	4.75	5.35	3.40	32.0
34.0	5.70	5.80	5.90	5.70	6.10	4.60	5.10	3.40	34.0
36.0	5.15	5.25	5.40	5.55	5.55	4.45	4.90	3.40	36.0
38.0	4.90 /37.1	4.80 /37.7	4.90	5.10	5.10	4.30	4.70	3.40	38.0
40.0			4.50	4.65	4.65	4.15	4.55	3.40	40.0
42.0			4.15	4.20	4.25	4.05	4.40	3.35	42.0
44.0			4.00 /42.8	3.90 /43.7	3.95	3.95	4.05	3.25	44.0
46.0					3.60	3.75	3.70	3.15	46.0
48.0					3.35	3.45	3.40	3.05	48.0
50.0					3.30 /48.4	3.20 /49.7	3.15	3.00	50.0
52.0							2.90	2.95	52.0
54.0							2.70	2.80	54.0
56.0							2.70 /54.1	2.60 /55.7	56.0

Unit: ton loads/working radius

Boom Length (m)	33								Boom Length (m)
Jib Length (m)	10		16		22		28		Jib Length (m)
Offset Angle (deg) Radius (m)	10	30	10	30	10	30	10	30	Offset Angle (deg) Radius (m)
10.0	12.00 /11.1								10.0
12.0	12.00		12.00 /13.2						12.0
14.0	12.00	11.20 /14.1	12.00		8.80 /15.3				14.0
16.0	12.00	10.65	12.00		8.80		5.50 /17.4		16.0
18.0	12.00	10.20	12.00	7.95	8.80		5.50		18.0
20.0	12.00	9.75	12.00	7.55	8.80	6.00 /21.9	5.50		20.0
22.0	10.90	9.40	11.25	7.25	8.80	5.95	5.50		22.0
24.0	9.60	9.05	9.90	6.95	8.80	5.70	5.50	3.40 /25.8	24.0
26.0	8.50	8.75	8.75	6.65	8.65	5.45	5.50	3.40	26.0
28.0	7.55	7.80	7.85	6.40	8.05	5.25	5.50	3.40	28.0
30.0	6.75	6.95	7.05	6.20	7.25	5.05	5.50	3.40	30.0
32.0	6.05	6.25	6.35	6.00	6.55	4.85	5.40	3.40	32.0
34.0	5.45	5.60	5.70	5.80	5.90	4.70	5.20	3.40	34.0
36.0	4.95	5.05	5.20	5.45	5.35	4.55	5.05	3.40	36.0
38.0	4.50	4.55	4.70	4.90	4.90	4.40	4.85	3.40	38.0
40.0	4.10 /39.7	4.10	4.30	4.45	4.45	4.25	4.60	3.40	40.0
42.0		4.05 /40.3	3.90	4.05	4.05	4.15	4.20	3.40	42.0
44.0			3.55	3.65	3.70	3.95	3.85	3.30	44.0
46.0			3.35 /45.4	3.30	3.40	3.60	3.50	3.20	46.0
48.0				3.25 /46.3	3.10	3.30	3.25	3.15	48.0
50.0					2.85	3.00	2.95	3.05	50.0
52.0					2.75 /51.0	2.70	2.70	2.95	52.0
54.0						2.65 /52.3	2.50	2.65	54.0
56.0							2.30	2.40	56.0
58.0							2.25 /56.7	2.20	58.0

- The rated loads are determined according to EN13000 rating on the condition that the machine is stationed on firm, level ground.
- The figures surrounded by bold lines are based on factors other than those which would cause a tipping condition.
- To calculate the maximum load that can actually be lifted, deduct weight of all lifting accessories, such as boom hook and jib hook, from figures shown above.
- Working radius is the horizontal distance from the slewing center to the center of gravity of a lifted load.
- The offset angles shown are of jib boom offset angle against the main boom, under load.
- The counterweight is 49.5 ton. (Upper weight 37.5 ton + Lower weight 12.0 ton)
- Hook weight are shown in the table below.

Hook Capacity (t)	Hook Weight (t)
100	1.20
50	1.17
35	0.90
12	0.51

■ Crane Jib



Unit: ton loads/working radius

Boom Length (m)	36								Boom Length (m)
Jib Length (m)	10		16		22		28		Jib Length (m)
Offset Angle (deg) Radius (m)	10	30	10	30	10	30	10	30	Offset Angle (deg) Radius (m)
11.7	12.00								11.7
12.0	12.00		12.00 /13.8						12.0
14.0	12.00	11.15 /14.7	12.00		8.80 /15.9				14.0
16.0	12.00	10.80	12.00		8.80				16.0
18.0	12.00	10.35	12.00	7.90 /18.6	8.80		5.50		18.0
20.0	12.00	9.95	12.00	7.65	8.80		5.50		20.0
22.0	10.65	9.55	11.00	7.35	8.80	5.95 /22.5	5.50		22.0
24.0	9.35	9.20	9.65	7.05	8.80	5.75	5.50		24.0
26.0	8.25	8.55	8.55	6.80	8.80	5.55	5.50	3.40 /26.4	26.0
28.0	7.30	7.60	7.60	6.55	7.85	5.30	5.50	3.40	28.0
30.0	6.50	6.75	6.80	6.30	7.00	5.10	5.50	3.40	30.0
32.0	5.80	6.00	6.10	6.10	6.30	4.95	5.50	3.40	32.0
34.0	5.20	5.40	5.50	5.80	5.70	4.75	5.35	3.40	34.0
36.0	4.70	4.85	4.95	5.25	5.15	4.60	5.15	3.40	36.0
38.0	4.20	4.35	4.45	4.75	4.65	4.50	4.80	3.40	38.0
40.0	3.80	3.90	4.05	4.25	4.25	4.35	4.35	3.40	40.0
42.0	3.45	3.50	3.65	3.85	3.85	4.15	4.00	3.40	42.0
44.0	3.40 /42.3	3.35 /42.9	3.30	3.45	3.50	3.75	3.65	3.35	44.0
46.0			3.00	3.15	3.20	3.40	3.30	3.30	46.0
48.0			2.70	2.80	2.90	3.10	3.00	3.20	48.0
50.0				2.70 /48.9	2.65	2.80	2.75	3.05	50.0
52.0					2.40	2.50	2.50	2.75	52.0
54.0					2.20 /53.6	2.25	2.30	2.50	54.0
56.0						2.20 /54.4	2.20 /54.8	2.25	56.0
56.4							2.20	2.20	56.4

Unit: ton loads/working radius

Boom Length (m)	39								Boom Length (m)
Jib Length (m)	10		16		22		28		Jib Length (m)
Offset Angle (deg) Radius (m)	10	30	10	30	10	30	10	30	Offset Angle (deg) Radius (m)
12.0	12.00 /12.2								12.0
14.0	12.00	11.15 /15.2	12.00 /14.3						14.0
16.0	12.00	10.95	12.00		8.80 /16.4				16.0
18.0	12.00	10.50	12.00	7.90 /19.1	8.80		5.50 /18.5		18.0
20.0	12.00	10.10	12.00	7.75	8.80		5.50		20.0
22.0	10.60	9.70	10.90	7.45	8.80	5.95 /23.0	5.50		22.0
24.0	9.25	9.40	9.60	7.15	8.80	5.85	5.50		24.0
26.0	8.15	8.50	8.45	6.90	8.70	5.60	5.50	3.40 /26.9	26.0
28.0	7.20	7.50	7.50	6.65	7.75	5.40	5.50	3.40	28.0
30.0	6.40	6.70	6.70	6.45	6.90	5.20	5.50	3.40	30.0
32.0	5.70	5.95	6.00	6.25	6.20	5.00	5.50	3.40	32.0
34.0	5.10	5.30	5.40	5.75	5.60	4.85	5.50	3.40	34.0
36.0	4.60	4.75	4.85	5.15	5.05	4.70	5.20	3.40	36.0
38.0	4.10	4.25	4.35	4.65	4.55	4.55	4.70	3.40	38.0
40.0	3.70	3.80	3.95	4.20	4.10	4.45	4.25	3.40	40.0
42.0	3.30	3.40	3.55	3.75	3.75	4.10	3.85	3.40	42.0
44.0	3.00	3.05	3.20	3.40	3.40	3.70	3.50	3.40	44.0
46.0	2.85 /44.9	2.80 /45.5	2.90	3.05	3.05	3.35	3.20	3.35	46.0
48.0			2.60	2.75	2.75	3.00	2.90	3.25	48.0
50.0			2.35	2.45	2.50	2.70	2.65	2.95	50.0
52.0			2.30 /50.6	2.25 /51.5	2.25	2.45	2.40	2.65	52.0
54.0					2.20 /52.5	2.20	2.20 /53.6	2.40	54.0
56.0							2.20 /55.6	2.20	56.0

- The rated loads are determined according to EN13000 rating on the condition that the machine is stationed on firm, level ground.
- The figures surrounded by bold lines are based on factors other than those which would cause a tipping condition.
- To calculate the maximum load that can actually be lifted, deduct weight of all lifting accessories, such as boom hook and jib hook, from figures shown above.
- Working radius is the horizontal distance from the slewing center to the center of gravity of a lifted load.
- The offset angles shown are of jib boom offset angle against the main boom, under load.
- The counterweight is 49.5 ton. (Upper weight 37.5 ton + Lower weight 12.0 ton)
- Hook weight are shown in the table below.

Hook Capacity (t)	Hook Weight (t)
100	1.20
50	1.17
35	0.90
12	0.51

■ Crane Jib



Unit: ton loads/working radius

Boom Length (m)	42								Boom Length (m)
Jib Length (m)	10		16		22		28		Jib Length (m)
Offset Angle (deg) Radius (m)	10	30	10	30	10	30	10	30	Offset Angle (deg) Radius (m)
12.0	12.00 /12.8								12.0
14.0	12.00	11.10 /15.8	12.00 /14.9						14.0
16.0	12.00	11.05	12.00		8.80 /17.0				16.0
18.0	12.00	10.60	12.00	7.85 /19.7	8.80		5.50 /19.1		18.0
20.0	12.00	10.25	12.00	7.85	8.80		5.50		20.0
22.0	10.35	9.85	10.70	7.50	8.80	5.95 /23.6	5.50		22.0
24.0	9.00	9.45	9.35	7.25	8.80	5.90	5.50		24.0
26.0	7.90	8.30	8.25	7.00	8.50	5.65	5.50	3.40 /27.5	26.0
28.0	6.95	7.30	7.30	6.75	7.55	5.45	5.50	3.40	28.0
30.0	6.15	6.45	6.45	6.55	6.70	5.25	5.50	3.40	30.0
32.0	5.50	5.75	5.75	6.20	6.00	5.10	5.50	3.40	32.0
34.0	4.85	5.10	5.15	5.55	5.35	4.90	5.50	3.40	34.0
36.0	4.35	4.55	4.60	5.00	4.80	4.75	5.00	3.40	36.0
38.0	3.85	4.05	4.15	4.45	4.35	4.65	4.50	3.40	38.0
40.0	3.45	3.60	3.70	4.00	3.90	4.35	4.05	3.40	40.0
42.0	3.05	3.20	3.30	3.55	3.50	3.90	3.65	3.40	42.0
44.0	2.75	2.80	2.95	3.20	3.15	3.50	3.30	3.40	44.0
46.0	2.45	2.50	2.65	2.85	2.85	3.15	3.00	3.40	46.0
48.0	2.20 /47.5	2.20	2.35	2.50	2.55	2.85	2.70	3.10	48.0
50.0		2.20 /48.1	2.20 /49.2	2.25	2.30	2.50	2.40	2.80	50.0
52.0				2.20 /50.3	2.20 /50.8	2.25	2.20 /51.6	2.50	52.0
54.0						2.20 /52.4		2.25	54.0
54.4								2.20	54.4

Unit: ton loads/working radius

Boom Length (m)	45								Boom Length (m)
Jib Length (m)	10		16		22		28		Jib Length (m)
Offset Angle (deg) Radius (m)	10	30	10	30	10	30	10	30	Offset Angle (deg) Radius (m)
12.0	12.00 /13.3								12.0
14.0	12.00		12.00 /15.4						14.0
16.0	12.00	11.10 /16.3	12.00		8.80 /17.5				16.0
18.0	12.00	10.75	12.00		8.80		5.50 /19.6		18.0
20.0	11.85	10.35	12.00	7.85 /20.2	8.80		5.50		20.0
22.0	10.20	10.00	10.55	7.60	8.80		5.50		22.0
24.0	8.85	9.35	9.20	7.35	8.80	5.95 /24.1	5.50		24.0
26.0	7.75	8.15	8.10	7.10	8.35	5.70	5.50		26.0
28.0	6.80	7.15	7.10	6.85	7.40	5.50	5.50	3.40	28.0
30.0	6.00	6.35	6.30	6.65	6.55	5.35	5.50	3.40	30.0
32.0	5.30	5.60	5.60	6.10	5.85	5.15	5.50	3.40	32.0
34.0	4.70	4.95	5.00	5.45	5.20	5.00	5.40	3.40	34.0
36.0	4.15	4.40	4.45	4.85	4.65	4.85	4.85	3.40	36.0
38.0	3.70	3.90	3.95	4.30	4.15	4.70	4.35	3.40	38.0
40.0	3.25	3.45	3.55	3.85	3.75	4.20	3.90	3.40	40.0
42.0	2.90	3.05	3.15	3.40	3.35	3.75	3.50	3.40	42.0
44.0	2.55	2.65	2.80	3.05	3.00	3.40	3.15	3.40	44.0
46.0	2.25	2.35	2.50	2.70	2.65	3.00	2.80	3.30	46.0
48.0	2.20 /46.3	2.20 /47.0	2.20	2.40	2.35	2.70	2.50	2.95	48.0
50.0				2.20 /49.3	2.20 /49.2	2.40	2.25	2.65	50.0
52.0						2.20 /51.3	2.20 /50.4	2.35	52.0
54.0								2.20 /53.2	54.0

- The rated loads are determined according to EN13000 rating on the condition that the machine is stationed on firm, level ground.
- The figures surrounded by bold lines are based on factors other than those which would cause a tipping condition.
- To calculate the maximum load that can actually be lifted, deduct weight of all lifting accessories, such as boom hook and jib hook, from figures shown above.
- Working radius is the horizontal distance from the slewing center to the center of gravity of a lifted load.
- The offset angles shown are of jib boom offset angle against the main boom, under load.
- The counterweight is 49.5 ton. (Upper weight 37.5 ton + Lower weight 12.0 ton)
- Hook weight are shown in the table below.

Hook Capacity (t)	Hook Weight (t)
100	1.20
50	1.17
35	0.90
12	0.51

Crane Jib



Unit: ton loads /working radius

48									
Boom Length (m)	48								Boom Length (m)
Jib Length (m)	10		16		22		28		Jib Length (m)
Offset Angle (deg)	10	30	10	30	10	30	10	30	Offset Angle (deg)
Radius (m)									Radius (m)
13.9	12.00								13.9
14.0	12.00								14.0
16.0	12.00	11.05 /16.9	12.00						16.0
18.0	12.00	10.85	12.00		8.80 /18.1				18.0
20.0	11.70	10.45	12.00	7.85 /20.8	8.80		5.50 /20.2		20.0
22.0	10.05	10.15	10.40	7.70	8.80		5.50		22.0
24.0	8.70	9.20	9.05	7.40	8.80	5.90 /24.6	5.50		24.0
26.0	7.60	8.05	7.90	7.15	8.20	5.75	5.50		26.0
28.0	6.65	7.05	6.95	6.95	7.25	5.55	5.50	3.40 /28.5	28.0
30.0	5.85	6.20	6.15	6.75	6.40	5.40	5.50	3.40	30.0
32.0	5.15	5.45	5.45	5.95	5.70	5.20	5.50	3.40	32.0
34.0	4.55	4.80	4.80	5.30	5.05	5.05	5.25	3.40	34.0
36.0	4.00	4.25	4.30	4.70	4.50	4.90	4.70	3.40	36.0
38.0	3.55	3.75	3.80	4.20	4.00	4.55	4.20	3.40	38.0
40.0	3.10	3.30	3.35	3.70	3.55	4.10	3.75	3.40	40.0
42.0	2.70	2.90	3.00	3.30	3.20	3.65	3.35	3.40	42.0
44.0	2.40	2.50	2.65	2.90	2.80	3.25	3.00	3.40	44.0
46.0	2.20 /45.3	2.20	2.30	2.55	2.50	2.90	2.65	3.20	46.0
48.0			2.20 /46.6	2.25	2.20	2.55	2.35	2.85	48.0
50.0				2.20 /48.3		2.25	2.20 /49.2	2.55	50.0
52.0						2.20 /50.4		2.25	52.0
52.3							2.20	2.20	52.3

Unit: ton loads /working radius

51									
Boom Length (m)	51								Boom Length (m)
Jib Length (m)	10		16		22		28		Jib Length (m)
Offset Angle (deg)	10	30	10	30	10	30	10	30	Offset Angle (deg)
Radius (m)									Radius (m)
14.0	12.00 /14.4								14.0
16.0	12.00	11.05 /17.4	12.00 /16.5						16.0
18.0	12.00	10.95	12.00		8.80 /18.6				18.0
20.0	11.40	10.60	11.75	7.85 /21.3	8.80		5.50 /20.7		20.0
22.0	9.90	10.25	10.30	7.75	8.80		5.50		22.0
24.0	8.60	9.10	8.95	7.50	8.80	5.90 /25.2	5.50		24.0
26.0	7.45	7.95	7.80	7.25	8.05	5.80	5.50		26.0
28.0	6.50	6.95	6.85	7.00	7.10	5.65	5.50	3.40 /29.1	28.0
30.0	5.70	6.10	6.00	6.65	6.25	5.45	5.50	3.40	30.0
32.0	5.00	5.35	5.30	5.85	5.55	5.30	5.50	3.40	32.0
34.0	4.40	4.70	4.70	5.20	4.90	5.10	5.10	3.40	34.0
36.0	3.85	4.10	4.15	4.60	4.35	5.00	4.55	3.40	36.0
38.0	3.35	3.60	3.65	4.05	3.85	4.45	4.05	3.40	38.0
40.0	2.95	3.15	3.20	3.60	3.45	4.00	3.60	3.40	40.0
42.0	2.55	2.75	2.85	3.15	3.05	3.55	3.20	3.40	42.0
44.0	2.20	2.40	2.45	2.80	2.70	3.15	2.85	3.40	44.0
46.0		2.20 /45.1	2.20 /45.6	2.45	2.35	2.75	2.50	3.05	46.0
48.0				2.20 /47.4	2.20 /47.0	2.45	2.20	2.75	48.0
50.0						2.20 /49.6		2.40	50.0
52.0							2.20 /51.6		52.0

1. The rated loads are determined according to EN13000 rating on the condition that the machine is stationed on firm, level ground.
2. The figures surrounded by bold lines are based on factors other than those which would cause a tipping condition.
3. To calculate the maximum load that can actually be lifted, deduct weight of all lifting accessories, such as boom hook and jib hook, from figures shown above.
4. Working radius is the horizontal distance from the slewing center to the center of gravity of a lifted load.
5. The offset angles shown are of jib boom offset angle against the main boom, under load.
6. The counterweight is 49.5 ton. (Upper weight 37.5 ton + Lower weight 12.0 ton)
7. Hook weight are shown in the table below.

Hook Capacity (t)	Hook Weight (t)
100	1.20
50	1.17
35	0.90
12	0.51

■ Main Boom with Crane Jib



Unit: ton loads /working radius

Boom Length (m)	24								Boom Length (m)
Jib Length (m)	10		16		22		28		Jib Length (m)
Offset Angle (deg)	10	30	10	30	10	30	10	30	Offset Angle (deg)
6.0	50.00 /6.1	50.00 /6.1	50.00 /6.1	50.00 /6.1	50.00 /6.1	50.00 /6.1	50.00 /6.1	50.00 /6.1	6.0
7.0	47.80	47.45	47.10	46.50	46.30	45.35	45.40	44.05	7.0
8.0	41.10	40.80	40.45	39.90	39.65	38.85	38.80	37.65	8.0
9.0	35.95	35.70	35.30	34.85	34.55	33.85	33.70	32.70	9.0
10.0	31.35	31.10	30.80	30.35	30.15	29.50	29.40	28.50	10.0
12.0	24.15	24.00	23.65	23.35	23.00	22.55	22.30	21.65	12.0
14.0	19.40	19.30	18.90	18.65	18.30	17.95	17.65	17.15	14.0
16.0	16.05	15.95	15.50	15.35	14.95	14.70	14.30	13.95	16.0
18.0	13.50	13.45	13.00	12.90	12.45	12.30	11.85	11.60	18.0
20.0	11.55	11.50	11.10	11.00	10.55	10.40	9.95	9.80	20.0
22.0	10.00	10.00	9.55	9.50	9.05	9.00	8.45	8.40	22.0
24.0	9.90 /22.2	9.85 /22.2	9.40 /22.2	9.40 /22.2	8.90 /22.2	8.85 /22.2	8.30 /22.2	8.25 /22.2	24.0

Unit: ton loads /working radius

Boom Length (m)	27								Boom Length (m)
Jib Length (m)	10		16		22		28		Jib Length (m)
Offset Angle (deg)	10	30	10	30	10	30	10	30	Offset Angle (deg)
6.0	48.35 /6.7	48.00 /6.7	47.70 /6.7	47.05 /6.7	46.95 /6.7	45.95 /6.7	46.10 /6.7	44.65 /6.7	6.0
7.0	46.10	45.75	45.45	44.85	44.70	43.75	43.85	42.50	7.0
8.0	39.75	39.50	39.15	38.60	38.40	37.60	37.60	36.45	8.0
9.0	34.85	34.60	34.25	33.80	33.55	32.85	32.75	31.75	9.0
10.0	30.95	30.70	30.35	29.95	29.65	29.05	28.85	28.00	10.0
12.0	24.10	23.95	23.60	23.30	23.00	22.50	22.35	21.65	12.0
14.0	19.35	19.20	18.85	18.60	18.30	17.90	17.65	17.10	14.0
16.0	15.95	15.85	15.45	15.30	14.90	14.65	14.30	13.90	16.0
18.0	13.40	13.35	12.95	12.80	12.40	12.20	11.80	11.50	18.0
20.0	11.45	11.40	11.00	10.90	10.50	10.30	9.90	9.70	20.0
22.0	9.90	9.85	9.45	9.35	8.95	8.85	8.40	8.25	22.0
24.0	8.65	8.60	8.20	8.15	7.70	7.65	7.15	7.10	24.0
26.0	8.20 /24.8	8.15 /24.8	7.75 /24.8	7.75 /24.8	7.30 /24.8	7.25 /24.8	6.75 /24.8	6.70 /24.8	26.0

1. The rated loads determined according to EN13000 rating on the condition that the machine is stationed on firm, level ground.
2. The figures surrounded by bold lines are based on factors other than those which would cause a tipping condition.
3. To calculate the maximum load that can actually be lifted, deduct weight of all lifting accessories, such as boom hook and jib hook, from figures shown above.
4. Working radius is the horizontal distance from the slewing center to the center of gravity of a lifted load.
5. The offset angles shown are of jib boom offset angle against the main boom, under load.
6. The counterweight is 49.5 ton. (Upper weight 37.5 ton + Lower weight 12.0 ton)
7. Hook weights are shown in the table below.

Hook Capacity (t)	Hook Weight (t)	Maximum Rated Loads (t)							
		8 falls	7 falls	6 falls	5 falls	4 falls	3 falls	2 falls	1 fall
100	1.20	100	84	72	60	48	-	-	-
50	1.17	-	-	-	50	48	36	24	-
35	0.90	-	-	-	-	-	35	24	-
12	0.51	-	-	-	-	-	-	-	12

■ Main Boom with Crane Jib



Unit: ton loads/working radius

Boom Length (m)	30								Boom Length (m)
Jib Length (m)	10		16		22		28		Jib Length (m)
Offset Angle (deg)	10	30	10	30	10	30	10	30	Offset Angle (deg)
7.0	43.15 /7.2	42.85 /7.2	42.55 /7.2	41.95 /7.2	41.85 /7.2	40.90 /7.2	41.00 /7.2	39.70 /7.2	7.0
8.0	38.50	38.20	37.90	37.35	37.20	36.40	36.40	35.25	8.0
9.0	33.80	33.55	33.20	32.75	32.55	31.85	31.80	30.80	9.0
10.0	30.05	29.80	29.45	29.05	28.80	28.20	28.05	27.20	10.0
12.0	23.95	23.75	23.45	23.10	22.90	22.35	22.25	21.50	12.0
14.0	19.15	19.00	18.70	18.40	18.15	17.75	17.55	16.95	14.0
16.0	15.75	15.65	15.30	15.10	14.75	14.45	14.20	13.75	16.0
18.0	13.25	13.15	12.80	12.60	12.25	12.00	11.70	11.35	18.0
20.0	11.25	11.20	13.00	10.70	10.30	10.10	9.75	9.50	20.0
22.0	9.70	9.65	9.25	9.15	8.75	8.65	8.25	8.05	22.0
24.0	8.45	8.40	8.00	7.95	7.50	7.40	7.00	6.85	24.0
26.0	7.40	7.35	6.95	6.90	6.50	6.45	6.00	5.90	26.0
28.0	6.75 /27.4	6.75 /27.4	6.35 /27.4	6.30 /27.4	5.90 /27.4	5.85 /27.4	5.40 /27.4	5.35 /27.4	28.0

Unit: ton loads/working radius

Boom Length (m)	33								Boom Length (m)
Jib Length (m)	10		16		22		28		Jib Length (m)
Offset Angle (deg)	10	30	10	30	10	30	10	30	Offset Angle (deg)
7.0	38.20 /7.8	37.90 /7.8	37.60 /7.8	37.05 /7.8	36.95 /7.8	36.10 /7.8	36.20 /7.8	35.00 /7.8	7.0
8.0	37.20	36.90	36.60	36.05	35.90	35.10	35.15	34.00	8.0
9.0	32.70	32.45	32.15	31.65	31.50	30.75	30.75	29.75	9.0
10.0	29.10	28.85	28.55	28.10	27.90	27.25	27.20	26.30	10.0
12.0	23.60	23.45	23.10	22.75	22.45	21.95	21.80	21.10	12.0
14.0	19.00	18.85	18.55	18.25	18.00	17.60	17.45	16.85	14.0
16.0	15.60	15.50	15.15	14.95	14.65	14.30	14.05	13.60	16.0
18.0	13.05	12.95	12.60	12.45	12.10	11.85	11.55	11.20	18.0
20.0	11.10	11.00	10.65	10.50	10.15	9.95	9.65	9.30	20.0
22.0	9.50	9.45	9.10	8.95	8.60	8.45	8.10	7.85	22.0
24.0	8.25	8.20	7.80	7.70	7.35	7.20	6.85	6.65	24.0
26.0	7.20	7.15	6.75	6.70	6.30	6.20	5.80	5.65	26.0
28.0	6.30	6.25	5.90	5.85	5.45	5.35	4.95	4.85	28.0
30.0	5.50	5.50	5.10	5.10	4.70	4.60	4.20	4.20	30.0

1. The rated loads determined according to EN13000 rating on the condition that the machine is stationed on firm, level ground.
2. The figures surrounded by bold lines are based on factors other than those which would cause a tipping condition.
3. To calculate the maximum load that can actually be lifted, deduct weight of all lifting accessories, such as boom hook and jib hook, from figures shown above.
4. Working radius is the horizontal distance from the slewing center to the center of gravity of a lifted load.
5. The offset angles shown are of jib boom offset angle against the main boom, under load.
6. The counterweight is 49.5 ton. (Upper weight 37.5 ton + Lower weight 12.0 ton)
7. Hook weights are shown in the table below.

Hook Capacity (t)	Hook Weight (t)	Maximum Rated Loads (t)							
		8 falls	7 falls	6 falls	5 falls	4 falls	3 falls	2 falls	1 fall
100	1.20	100	84	72	60	48	-	-	-
50	1.17	-	-	-	50	48	36	24	-
35	0.90	-	-	-	-	-	35	24	-
12	0.51	-	-	-	-	-	-	-	12

■ Main Boom with Crane Jib



Unit: ton loads /working radius

Boom Length (m)	36								Boom Length (m)
Jib Length (m)	10		16		22		28		Jib Length (m)
Offset Angle (deg) Radius (m)	10	30	10	30	10	30	10	30	Offset Angle (deg) Radius (m)
	8.0	34.55 /8.3	34.30 /8.3	34.00 /8.3	33.50 /8.3	33.35 /8.3	32.60 /8.3	32.65 /8.3	
9.0	31.70	31.40	31.10	30.65	30.50	29.80	29.80	28.80	9.0
10.0	28.20	28.00	27.65	27.25	27.05	26.40	26.35	25.45	10.0
12.0	22.90	22.75	22.40	22.05	21.80	21.30	21.15	20.45	12.0
14.0	18.80	18.65	18.35	18.05	17.80	17.40	17.25	16.60	14.0
16.0	15.40	15.25	14.95	14.70	14.45	14.10	13.90	13.40	16.0
18.0	12.85	12.70	12.40	12.20	11.90	11.60	11.40	10.95	18.0
20.0	10.85	10.75	10.45	10.25	9.95	9.70	9.45	9.10	20.0
22.0	9.30	9.20	13.00	8.75	8.40	8.20	7.90	7.60	22.0
24.0	8.00	7.90	7.60	7.50	7.15	6.95	6.60	6.40	24.0
26.0	6.95	6.85	6.55	6.45	6.10	5.95	5.60	5.40	26.0
28.0	6.05	6.00	5.65	5.55	5.20	5.10	4.70	4.60	28.0
30.0	5.30	5.25	4.90	4.85	4.45	4.40	4.00	3.90	30.0
32.0	4.65	4.60	4.25	4.20	3.85	3.80	3.35	3.30	32.0
34.0	4.45 /32.6	4.45 /32.6	4.10 /32.6	4.05 /32.6	3.65 /32.6	3.65 /32.6	3.20 /32.6	3.15 /32.6	34.0

Unit: ton loads /working radius

Boom Length (m)	39								Boom Length (m)
Jib Length (m)	10		16		22		28		Jib Length (m)
Offset Angle (deg) Radius (m)	10	30	10	30	10	30	10	30	Offset Angle (deg) Radius (m)
	8.0	31.50 /8.8	31.25 /8.8	30.95 /8.8	30.45 /8.8	30.35 /8.8	29.60 /8.8	29.65 /8.8	
9.0	30.75	30.50	30.20	29.75	29.60	28.85	28.90	27.90	9.0
10.0	27.40	27.20	26.90	26.45	26.30	25.65	25.60	24.70	10.0
12.0	22.30	22.15	21.80	21.45	21.25	20.70	20.60	19.85	12.0
14.0	18.60	18.45	18.10	17.80	17.55	17.10	16.90	16.35	14.0
16.0	15.35	15.20	14.95	14.70	14.45	14.05	13.90	13.35	16.0
18.0	12.80	12.70	12.40	12.20	11.90	11.60	11.40	10.95	18.0
20.0	10.80	10.70	10.40	10.25	9.95	9.70	9.45	9.05	20.0
22.0	9.25	9.15	8.85	8.70	8.40	8.15	7.90	7.60	22.0
24.0	7.95	7.85	7.55	7.45	7.10	6.95	6.60	6.35	24.0
26.0	6.90	6.80	6.50	6.40	6.05	5.90	5.55	5.35	26.0
28.0	6.00	5.90	5.60	5.50	5.15	5.05	4.70	4.55	28.0
30.0	5.20	5.15	4.80	4.75	4.40	4.30	3.95	3.80	30.0
32.0	4.55	4.50	4.15	4.10	3.75	3.70	3.30	3.20	32.0
34.0	4.00	3.95	3.60	3.55	3.20	3.15	2.75	2.70	34.0
36.0	3.65 /35.2	3.65 /35.2	3.30 /35.2	3.30 /35.2	2.90 /35.2	2.85 /35.2	2.45 /35.2	2.45 /35.2	36.0

- The rated loads determined according to EN13000 rating on the condition that the machine is stationed on firm, level ground.
- The figures surrounded by bold lines are based on factors other than those which would cause a tipping condition.
- To calculate the maximum load that can actually be lifted, deduct weight of all lifting accessories, such as boom hook and jib hook, from figures shown above.
- Working radius is the horizontal distance from the slewing center to the center of gravity of a lifted load.
- The offset angles shown are of jib boom offset angle against the main boom, under load.
- The counterweight is 49.5 ton. (Upper weight 37.5 ton + Lower weight 12.0 ton)
- Hook weights are shown in the table below.

Hook Capacity (t)	Hook Weight (t)	Maximum Rated Loads (t)							
		8 falls	7 falls	6 falls	5 falls	4 falls	3 falls	2 falls	1 fall
100	1.20	100	84	72	60	48	-	-	-
50	1.17	-	-	-	50	48	36	24	-
35	0.90	-	-	-	-	-	35	24	-
12	0.51	-	-	-	-	-	-	-	12

■ Main Boom with Crane Jib



Unit: ton loads /working radius

Boom Length (m)	42								Boom Length (m)
Jib Length (m)	10		16		22		28		Jib Length (m)
Offset Angle (deg) Radius (m)	10	30	10	30	10	30	10	30	Offset Angle (deg) Radius (m)
	9.0	28.45 /9.4	28.20 /9.4	27.90 /9.4	27.45 /9.4	27.30 /9.4	26.65 /9.4	26.65 /9.4	
10.0	26.60	26.35	26.05	25.65	25.50	24.85	24.85	23.95	10.0
12.0	21.65	21.45	21.15	20.80	20.60	20.05	19.95	19.25	12.0
14.0	18.05	17.85	17.55	17.25	17.00	16.55	16.40	15.80	14.0
16.0	15.15	15.00	14.70	14.45	14.25	13.85	13.65	13.15	16.0
18.0	12.55	12.45	12.15	11.95	11.70	11.35	11.20	10.75	18.0
20.0	10.60	10.50	10.20	10.00	9.75	9.45	9.25	8.85	20.0
22.0	9.00	8.90	8.60	8.45	8.15	7.95	7.65	7.35	22.0
24.0	7.70	7.65	7.30	7.20	6.90	6.70	6.40	6.15	24.0
26.0	6.65	6.55	6.25	6.15	5.80	5.65	5.35	5.10	26.0
28.0	5.75	5.65	5.35	5.25	4.90	4.80	4.45	4.30	28.0
30.0	4.95	4.90	4.60	4.50	4.15	4.05	3.70	3.55	30.0
32.0	4.30	4.25	3.90	3.85	3.50	3.40	3.05	2.95	32.0
34.0	3.70	3.70	3.35	3.30	2.95	2.90	2.50	2.40	34.0
36.0	3.20	3.20	2.85	2.80	2.45	2.40	2.20 /35.2	2.20 /34.8	36.0
38.0	2.80 /37.8	2.80 /37.8	2.45 /37.8	2.45 /37.8	2.20 /37.1	2.20 /37.0			38.0

Unit: ton loads /working radius

Boom Length (m)	45								Boom Length (m)
Jib Length (m)	10		16		22		28		Jib Length (m)
Offset Angle (deg) Radius (m)	10	30	10	30	10	30	10	30	Offset Angle (deg) Radius (m)
	9.0	26.15 /9.9	25.90 /9.9	25.65 /9.9	25.20 /9.9	25.05 /9.9	24.40 /9.9	24.45 /9.9	
10.0	25.85	25.60	25.35	24.95	24.80	24.15	24.15	23.25	10.0
12.0	21.10	20.90	20.60	20.25	20.05	19.55	19.45	18.70	12.0
14.0	17.55	17.40	17.10	16.80	16.55	16.10	15.95	15.35	14.0
16.0	14.85	14.75	14.40	14.15	13.90	13.50	13.30	12.80	16.0
18.0	12.45	12.30	12.00	11.80	11.55	11.25	11.05	10.60	18.0
20.0	10.45	10.30	10.05	9.85	9.60	9.30	9.10	8.70	20.0
22.0	8.85	8.75	8.45	8.30	8.00	7.80	7.55	7.20	22.0
24.0	7.55	7.45	7.15	7.05	6.75	6.55	6.25	6.00	24.0
26.0	6.50	6.40	6.10	6.00	5.65	5.50	5.20	4.95	26.0
28.0	5.55	5.50	5.20	5.10	4.80	4.65	4.30	4.10	28.0
30.0	4.80	4.75	4.40	4.35	4.00	3.90	3.55	3.40	30.0
32.0	4.15	4.10	3.75	3.70	3.35	3.25	2.90	2.80	32.0
34.0	3.55	3.50	3.20	3.15	2.80	2.70	2.35	2.25	34.0
36.0	3.05	3.00	2.70	2.65	2.30	2.25	2.20 /34.6	2.20 /34.2	36.0
38.0	2.60	2.55	2.25	2.20	2.20 /36.4	2.20 /36.2			38.0
40.0	2.20	2.20	2.20 /38.2						40.0

- The rated loads determined according to EN13000 rating on the condition that the machine is stationed on firm, level ground.
- The figures surrounded by bold lines are based on factors other than those which would cause a tipping condition.
- To calculate the maximum load that can actually be lifted, deduct weight of all lifting accessories, such as boom hook and jib hook, from figures shown above.
- Working radius is the horizontal distance from the slewing center to the center of gravity of a lifted load.
- The offset angles shown are of jib boom offset angle against the main boom, under load.
- The counterweight is 49.5 ton. (Upper weight 37.5 ton + Lower weight 12.0 ton)
- Hook weights are shown in the table below.

Hook Capacity (t)	Hook Weight (t)	Maximum Rated Loads (t)							
		8 falls	7 falls	6 falls	5 falls	4 falls	3 falls	2 falls	1 fall
100	1.20	100	84	72	60	48	-	-	-
50	1.17	-	-	-	50	48	36	24	-
35	0.90	-	-	-	-	-	35	24	-
12	0.51	-	-	-	-	-	-	-	12

■ Main Boom with Crane Jib



Unit: ton loads /working radius

48									
Boom Length (m)									Boom Length (m)
Jib Length (m)	10		16		22		28		Jib Length (m)
Offset Angle (deg)	10	30	10	30	10	30	10	30	Offset Angle (deg)
10.0	23.90 /10.5	23.65 /10.5	23.40 /10.5	23.00 /10.5	22.85 /10.5	22.25 /10.5	22.20 /10.5	21.35 /10.5	10.0
12.0	20.55	20.35	20.10	19.75	19.55	19.00	18.95	18.20	12.0
14.0	17.15	16.95	16.65	16.35	16.15	15.70	15.55	14.95	14.0
16.0	14.50	14.35	14.05	13.80	13.55	13.15	12.95	12.45	16.0
18.0	12.30	12.15	11.90	11.65	11.45	11.10	10.90	10.45	18.0
20.0	10.30	10.20	9.90	9.70	9.45	9.15	9.00	8.55	20.0
22.0	8.70	8.60	8.30	8.15	7.90	7.65	7.40	7.05	22.0
24.0	7.40	7.30	7.05	6.90	6.60	6.40	6.15	5.85	24.0
26.0	6.35	6.25	6.00	5.85	5.55	5.35	5.10	4.85	26.0
28.0	5.45	5.35	5.05	4.95	4.65	4.50	4.20	4.00	28.0
30.0	4.65	4.60	4.30	4.20	3.90	3.75	3.45	3.25	30.0
32.0	4.00	3.95	3.60	3.55	3.20	3.10	2.80	2.65	32.0
34.0	3.40	3.35	3.05	2.95	2.65	2.55	2.20	2.20 /33.6	34.0
36.0	2.90	2.85	2.55	2.50	2.20 /35.8	2.20 /35.4			36.0
38.0	2.45	2.40	2.20 /37.5	2.20 /37.3					38.0
40.0	2.20 /39.2	2.20 /39.0							40.0

Unit: ton loads /working radius

51									
Boom Length (m)									Boom Length (m)
Jib Length (m)	10		16		22		28		Jib Length (m)
Offset Angle (deg)	10	30	10	30	10	30	10	30	Offset Angle (deg)
10.0	20.45 /11.1	20.35 /11.1	19.85 /11.1	19.70 /11.1	19.20 /11.1	18.95 /11.1	18.45 /11.1	18.10 /11.1	10.0
12.0	19.85	19.65	19.40	19.05	18.75	18.35	18.00	17.55	12.0
14.0	16.55	16.35	16.05	15.75	15.55	15.10	15.00	14.35	14.0
16.0	13.95	13.80	13.50	13.25	13.00	12.60	12.45	11.90	16.0
18.0	11.90	11.80	11.45	11.25	10.95	10.65	10.45	9.95	18.0
20.0	10.20	10.05	9.80	9.60	9.30	9.00	8.80	8.40	20.0
22.0	8.60	8.45	8.20	8.00	7.75	7.50	7.30	6.95	22.0
24.0	7.25	7.20	6.90	6.75	6.50	6.25	6.00	5.70	24.0
26.0	6.20	6.10	5.80	5.70	5.40	5.20	4.95	4.70	26.0
28.0	5.25	5.20	4.90	4.80	4.50	4.35	4.05	3.80	28.0
30.0	4.50	4.40	4.10	4.00	3.70	3.55	3.30	3.10	30.0
32.0	3.80	3.75	3.45	3.35	3.05	2.95	2.65	2.45	32.0
34.0	3.20	3.15	2.85	2.80	2.50	2.35	2.20 /33.5	2.20 /32.9	34.0
36.0	2.70	2.65	2.35	2.30	2.20 /35.0	2.20 /34.6			36.0
38.0	2.25	2.20	2.20 /36.6	2.20 /36.4					38.0
40.0	2.20 /38.2								40.0

- The rated loads determined according to EN13000 rating on the condition that the machine is stationed on firm, level ground.
- The figures surrounded by bold lines are based on factors other than those which would cause a tipping condition.
- To calculate the maximum load that can actually be lifted, deduct weight of all lifting accessories, such as boom hook and jib hook, from figures shown above.
- Working radius is the horizontal distance from the slewing center to the center of gravity of a lifted load.
- The offset angles shown are of jib boom offset angle against the main boom, under load.
- The counterweight is 49.5 ton. (Upper weight 37.5 ton + Lower weight 12.0 ton)
- Hook weights are shown in the table below.

Hook Capacity (t)	Hook Weight (t)	Maximum Rated Loads (t)							
		8 falls	7 falls	6 falls	5 falls	4 falls	3 falls	2 falls	1 fall
100	1.20	100	84	72	60	48	-	-	-
50	1.17	-	-	-	50	48	36	24	-
35	0.90	-	-	-	-	-	35	24	-
12	0.51	-	-	-	-	-	-	-	12

■ Main Boom (Using Third Winch)



Unit: ton loads/working radius

Working Radius(m)	Boom Length (m)										Working Radius(m)	
	12	15	18	21	24	27	30	33	36	39		
3.8	90.00											3.8
4.0	90.00											4.0
4.5	84.40	84.40										4.5
5.0	75.95	75.95	75.95									5.0
5.5	69.05	69.05	68.80	65.70 /5.6								5.5
6.0	63.30	63.30	62.85	60.75	57.25 /6.1	49.85 /6.7						6.0
7.0	54.10	54.10	53.00	51.15	49.30	47.60	44.65 /7.2	39.65 /7.8				7.0
8.0	44.90	44.90	44.75	44.05	42.60	41.25	39.95	38.65	36.00 /8.3	32.95 /8.8		8.0
9.0	38.10	38.05	37.90	37.85	37.45	36.35	35.30	34.15	33.15	32.20		9.0
10.0	33.00	32.90	32.75	32.70	32.60	32.40	31.55	30.55	29.70	28.90		10.0
12.0	26.50 /11.8	25.80	25.60	25.55	25.40	25.35	25.15	25.00	24.40	23.80		12.0
14.0		21.10	20.90	20.80	20.65	20.60	20.40	20.25	20.00	20.00		14.0
16.0		20.30 /14.4	17.50	17.45	17.25	17.20	17.00	16.85	16.60	16.55		16.0
18.0			16.20 /17.0	14.90	14.75	14.65	14.45	14.30	14.05	14.00		18.0
20.0				13.35 /19.6	12.80	12.70	12.50	12.30	12.05	12.05		20.0
22.0					11.25	11.10	10.90	10.70	10.50	10.45		22.0
24.0					11.10 /22.2	9.85	9.65	9.45	9.20	9.15		24.0
26.0						9.40 /24.8	8.60	8.35	8.10	8.10		26.0
28.0							7.95 /27.4	7.45	7.20	7.15		28.0
30.0								6.70	6.45	6.40		30.0
32.0									5.80	5.75		32.0
34.0									5.60 /32.6	5.15		34.0
36.0										4.85 /35.2		36.0

Unit: ton loads/working radius

Working Radius(m)	Boom Length (m)							Working Radius(m)
	42	45	48	51	54	57	60	
9.0	29.90 /9.4	27.60 /9.9						9.0
10.0	28.05	27.35	25.35 /10.5	23.10 /11.1	19.85 /11.6			10.0
12.0	23.15	22.55	22.05	21.35	19.65	18.55 /12.2	14.90 /12.7	12.0
14.0	19.50	19.05	18.65	18.05	17.60	17.15	14.40	14.0
16.0	16.35	16.20	16.00	15.45	15.10	14.70	13.70	16.0
18.0	13.80	13.65	13.50	13.40	13.05	12.75	12.35	18.0
20.0	11.80	11.65	11.50	11.40	11.25	11.15	10.75	20.0
22.0	10.20	10.05	9.95	9.80	9.65	9.55	9.30	22.0
24.0	8.90	8.75	8.65	8.50	8.35	8.20	8.00	24.0
26.0	7.85	7.70	7.55	7.40	7.25	7.15	6.90	26.0
28.0	6.95	6.80	6.65	6.50	6.35	6.20	6.00	28.0
30.0	6.15	6.00	5.85	5.70	5.55	5.40	5.20	30.0
32.0	5.50	5.35	5.20	5.05	4.90	4.75	4.50	32.0
34.0	4.90	4.75	4.60	4.45	4.30	4.15	3.90	34.0
36.0	4.40	4.25	4.10	3.90	3.75	3.60	3.40	36.0
38.0	4.00 /37.8	3.75	3.65	3.45	3.30	3.15	2.90	38.0
40.0		3.35	3.20	3.05	2.90	2.75	2.50	40.0
42.0		3.30 /40.4	2.85	2.65	2.50	2.35	2.15	42.0
44.0			2.70 /43.0	2.35	2.20	2.05	1.80	44.0
46.0				2.15 /45.3	1.90	1.75	1.70 /44.8	46.0
48.0					1.70 /47.4	1.70 /46.3		48.0

1. The rated loads are determined according to EN13000 rating on the condition that the machine is stationed on firm, level ground.
2. The figures surrounded by bold lines are based on factors other than those which would cause a tipping condition.
3. To calculate the maximum load that can actually be lifted, deduct weight of all lifting accessories, such as boom hook and jib hook, from figures shown above.
4. Working radius is the horizontal distance from the slewing center to the center of gravity of a lifted load.
5. The counterweight is 49.5 ton. (Upper weight 37.5 ton + Lower weight 12.0 ton)
6. Hook weights are shown in the table below.

Hook Capacity (t)	Hook Weight (t)	Maximum Rated Loads (t)							
		8 falls	7 falls	6 falls	5 falls	4 falls	3 falls	2 falls	1 fall
100	1.20	100	84	72	60	48	-	-	-
50	1.17	-	-	-	50	48	36	24	-
35	0.90	-	-	-	-	-	35	24	-
12	0.51	-	-	-	-	-	-	-	12

■ Main Boom with Aux. Sheave (Using Third Winch)



Unit: ton loads / working radius

Working Radius(m)	Boom Length (m)										Working Radius(m)	
	12	15	18	21	24	27	30	33	36	39		
3.8	90.00											3.8
4.0	90.00											4.0
4.5	84.40	84.40										4.5
5.0	75.95	75.95	75.95									5.0
5.5	69.05	69.05	68.80	65.10 / 5.6								5.5
6.0	63.30	63.30	62.80	60.20	56.65 / 6.1	49.25 / 6.7						6.0
7.0	54.10	54.10	52.45	50.55	48.70	47.00	44.05 / 7.2	39.05 / 7.8				7.0
8.0	44.50	44.45	44.30	43.50	42.00	40.70	39.40	38.05	35.40 / 8.3	32.35 / 8.8		8.0
9.0	37.70	37.65	37.45	37.40	36.85	35.75	34.70	33.55	32.55	31.60		9.0
10.0	32.60	32.55	32.35	32.30	32.15	31.85	30.95	29.95	29.05	28.25		10.0
12.0	26.10 / 11.8	25.40	25.20	25.15	25.00	24.90	24.70	24.50	23.80	23.15		12.0
14.0		20.70	20.50	20.40	20.25	20.15	19.95	19.80	19.55	19.45		14.0
16.0		19.95 / 14.4	17.15	17.05	16.85	16.75	16.55	16.40	16.15	16.10		16.0
18.0			15.80 / 17.0	14.55	14.35	14.25	14.05	13.85	13.60	13.55		18.0
20.0				12.95 / 19.6	12.40	12.25	12.05	11.85	11.60	11.55		20.0
22.0					10.85	10.70	10.50	10.30	10.05	10.00		22.0
24.0					10.70 / 22.2	9.45	9.25	9.00	8.75	8.70		24.0
26.0						9.00 / 24.8	8.20	7.95	7.70	7.65		26.0
28.0							7.55 / 27.4	7.05	6.80	6.75		28.0
30.0								6.30	6.05	5.95		30.0
32.0									5.40	5.30		32.0
34.0									5.20 / 32.6	4.75		34.0
36.0										4.45 / 35.2		36.0

Unit: ton loads / working radius

Working Radius(m)	Boom Length (m)						Working Radius(m)
	42	45	48	51	54	57	
9.0	29.25 / 9.4	26.95 / 9.9					9.0
10.0	27.40	26.70	24.70 / 10.5	22.10 / 11.1	18.85 / 11.6		10.0
12.0	22.50	21.90	21.40	20.70	18.65	17.50 / 12.2	12.0
14.0	18.90	18.40	17.95	17.35	16.90	16.45	14.0
16.0	15.85	15.70	15.35	14.80	14.40	14.00	16.0
18.0	13.30	13.15	13.00	12.75	12.40	12.05	18.0
20.0	11.35	11.15	11.00	10.90	10.75	10.45	20.0
22.0	9.75	9.60	9.45	9.30	9.15	9.00	22.0
24.0	8.45	8.30	8.15	8.00	7.85	7.70	24.0
26.0	7.40	7.20	7.05	6.90	6.75	6.60	26.0
28.0	6.50	6.30	6.15	6.00	5.85	5.70	28.0
30.0	5.70	5.55	5.40	5.20	5.05	4.90	30.0
32.0	5.05	4.85	4.70	4.55	4.40	4.20	32.0
34.0	4.45	4.30	4.15	3.95	3.80	3.65	34.0
36.0	3.95	3.80	3.60	3.45	3.25	3.10	36.0
38.0	3.55 / 37.8	3.35	3.15	3.00	2.80	2.65	38.0
40.0		2.95	2.80	2.55	2.40	2.25	40.0
42.0		2.85 / 40.4	2.45	2.20	2.20 / 41.2	2.20 / 40.3	42.0
44.0			2.25 / 43.0	2.20 / 42.2			44.0

1. The rated loads are determined according to EN13000 rating on the condition that the machine is stationed on firm, level ground.
2. The figures surrounded by bold lines are based on factors other than those which would cause a tipping condition.
3. To calculate the maximum load that can actually be lifted, deduct weight of all lifting accessories, such as boom hook and jib hook, from figures shown above.
4. Working radius is the horizontal distance from the slewing center to the center of gravity of a lifted load.
5. The counterweight is 49.5 ton. (Upper weight 37.5 ton + Lower weight 12.0 ton)
6. Hook weights are shown in the table below.

Hook Capacity (t)	Hook Weight (t)	Maximum Rated Loads (t)							
		8 falls	7 falls	6 falls	5 falls	4 falls	3 falls	2 falls	1 fall
100	1.20	100	84	72	60	48	-	-	-
50	1.17	-	-	-	50	48	36	24	-
35	0.90	-	-	-	-	-	35	24	-
12	0.51	-	-	-	-	-	-	-	12

Clamshell Specifications

Dimensions and Specifications

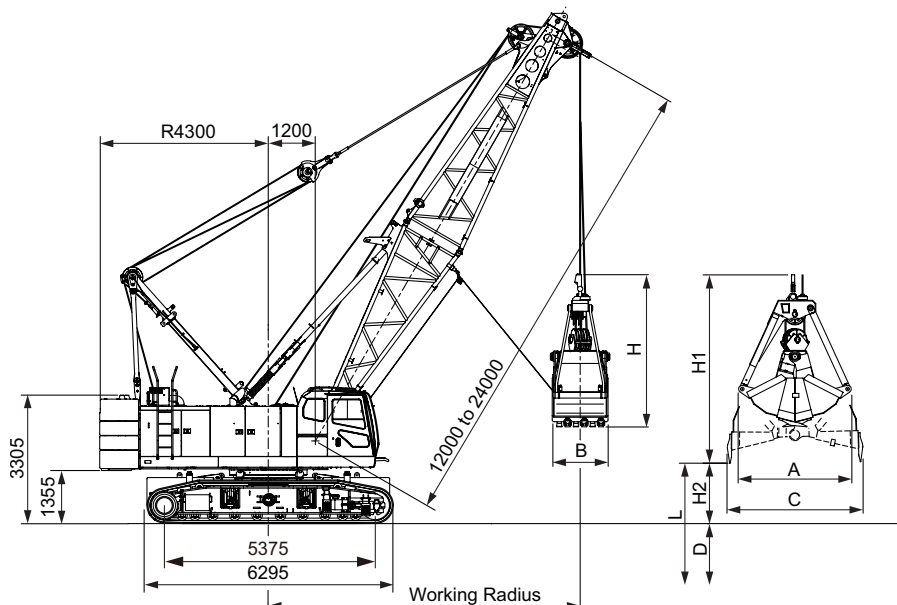

Working Ranges

Boom Length	m	12				15				18				21				24			
Boom Angle	°	35	45	55	65	35	45	55	65	35	45	55	65	35	45	55	65	35	45	55	65
Working Radius	m	11.6	10.4	8.8	7.1	14.0	12.5	10.5	8.4	16.5	14.6	12.3	9.6	19.0	16.7	14.0	10.9	21.4	18.8	15.7	12.2
Gross Rated Load	t	10.0	10.0	10.0	10.0	10.0	10.0	10.0	10.0	10.0	10.0	10.0	10.0	10.0	10.0	10.0	10.0	10.0	10.0	10.0	10.0
Lift L (D + H2)	m	37.2	38.8	40.2	41.4	38.8	40.9	42.6	44.0	40.4	42.9	45.0	46.7	42.0	44.9	47.4	49.3	43.6	47.0	49.8	52.0
Max. Digging Depth D	m	36																			
Bucket Dumping Height H2	m	1.2	2.8	4.2	5.4	2.8	4.9	6.6	8.0	4.4	6.9	9.0	10.7	6.0	8.9	11.4	13.3	7.6	11.0	13.8	16.0

Specifications

Clamshell Specifications	
Bucket Capacity	m ³ 3.0
Allowed Maximum Gross Weight for Clamshell Bucket and Captured Load Combined	t 10
Boom Length	m 12 to 24
Maximum Digging Depth	m 36
Support Wire Rope Speed *	m/min 64
Opening/Closing Wire Rope Speed *	m/min 64
Boom Hoist Drum Wire Rope Speed (Raise) *	m/min 44
Boom Hoist Drum Wire Rope Speed (Lower) *	m/min 44
Ground Contact Pressure	kPa (kgf/cm ²) 116 (1.18) (w/ Basic Boom, 3.0 m ³ Clamshell Bucket)
Overall Operating Weight	t Approximately 103 (w/ Basic Boom, 3.0 m ³ Clamshell Bucket)

NOTE :

- Speeds marked with "*" may vary depending on load applied.
- SI units are used for specifications. In parenthesis, conventional units are also indicated.
- Specifications other than those shown above are the same as those shown in the crane specifications section.

Clamshell Bucket

Capacity (m ³)	Weight (t)	A (mm)	B (mm)	C (mm)	H (mm)	H1 (mm)
3.0	6.5	2,980	1,650	3,500	3,550	4,550

Gross Rated Load Table

Working Radius (m)	Boom Length (m)					Unit ; ton
	12	15	18	21	24	
7.1	10.00/7.1					
8.0	10.00	10.00/8.4				
9.0	10.00	10.00	10.00/9.6			
10.0	10.00	10.00	10.00	10.00/10.9		
12.0	10.00/11.6	10.00	10.00	10.00	10.00/12.2	
14.0		10.00	10.00	10.00	10.00	
16.0			10.00	10.00	10.00	
18.0			10.00/16.5	10.00	10.00	
20.0				10.00/19.0	10.00	
21.4					9.30/21.4	

1. Max. clamshell rating is 10.0 t.
2. Mass of bucket plus load should not exceed clamshell ratings shown above. Following data are for a general digging application buckets.

Bucket Capacity	2.0 m ³	2.5 m ³	3.0 m ³
Bucket Mass	4.5 t	5.5 t	6.5 t

3. In case of clamshell application, a 12 m boom is recommended as minimum length of boom, and max. boom length shall not exceed 24 m.
4. Apparent specific gravity of lifting material :
Earth 1.7 to 1.8 t/m³
Gravel 1.8 to 2.0 t/m³
5. Upper weights should be used in an assembly configuration (31.7 t) excluding right and left top weights.
6. Max. digging depth below ground shall be 36 m.

Weights and Dimensions of Disassembled Units

Weights and Dimensions List

Weights and Dimensions of Disassembled Units

Description	Qty	Dimensions (mm)	Weight (kg)
Base Crane with: Boom Base Front Winch Wire Rope Rear Winch Wire Rope Boom Hoist Winch Wire Rope Crawlers Jack Without: Floats	1		50400
Base Crane with: Front Winch Wire Rope Rear Winch Wire Rope Boom Hoist Winch Wire Rope Crawlers Jack Without: Floats	1		48200
Base Crane with: Boom Base Front Winch Wire Rope Rear Winch Wire Rope Boom Hoist Winch Wire Rope Jack Without: Floats	1		31300
Base Crane with: Front Winch Wire Rope Rear Winch Wire Rope Boom Hoist Winch Wire Rope Jack Without: Floats	1		29100
Crawler	2		9600

Weights and Dimensions of Disassembled Units

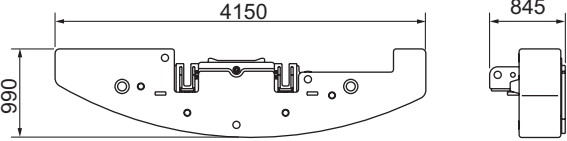
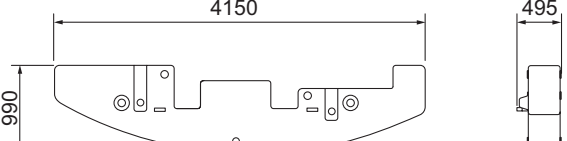
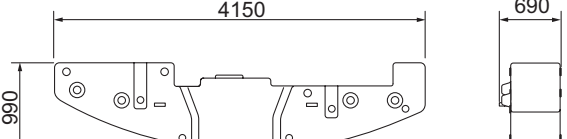
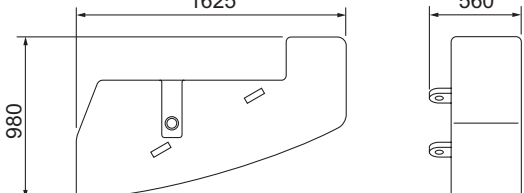
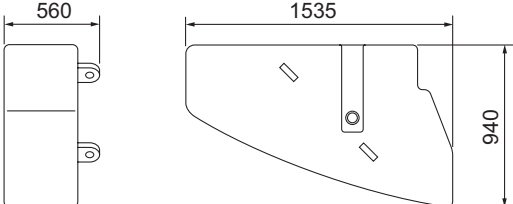
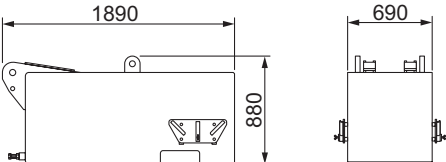
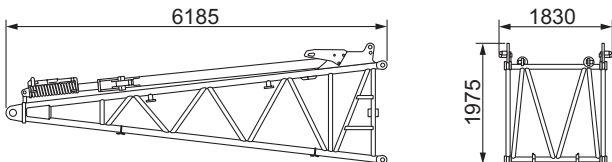
Description	Qty	Dimensions (mm)	Weight (kg)
Counter Weight (Base)	1		9420
Counter Weight	2		6640
Counter Weight	1		8980
Counter Weight	1		2810
Counter Weight	1		3000
Lower Weight	2		6040
Boom Base	1		1720

Weights and Dimensions of Disassembled Units

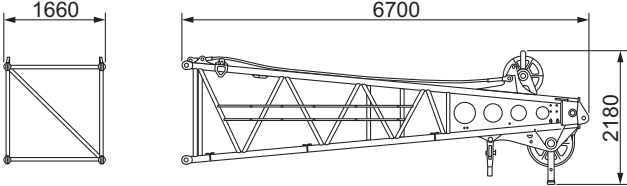
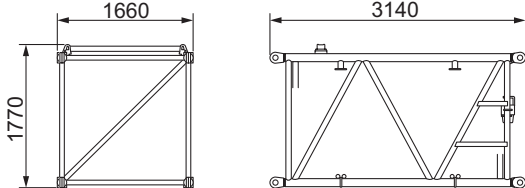
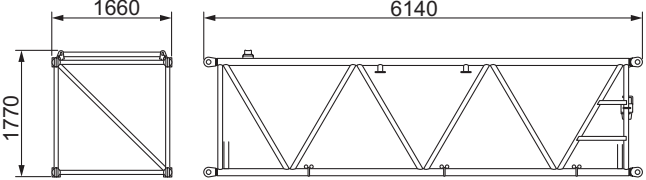
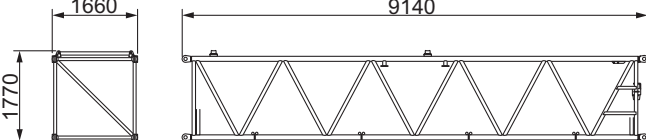
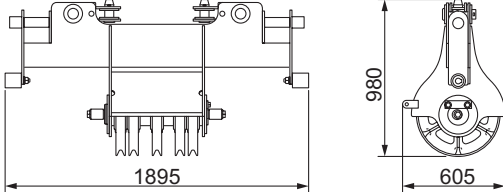
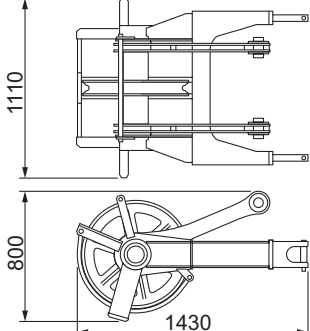
Description	Qty	Dimensions (mm)	Weight (kg)
Boom Top	1		1650
3 m Boom Insert	1		430
6 m Boom Insert	1		690
9 m Boom Insert	1		1000
Upper Spreader	1		490
Aux. Sheave	1		340

Weights and Dimensions of Disassembled Units

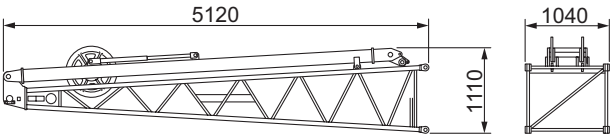
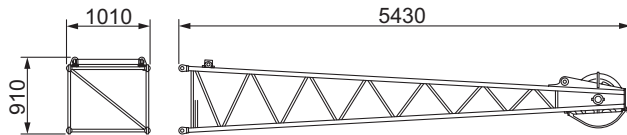
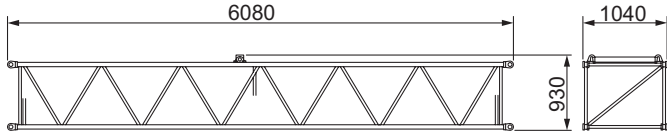
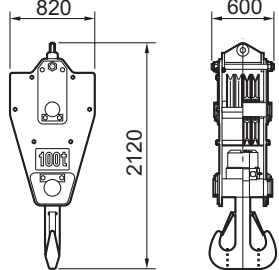
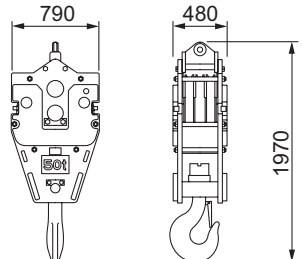
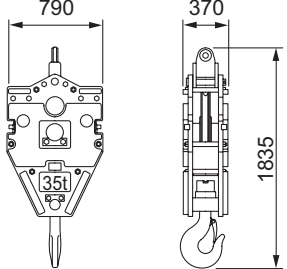
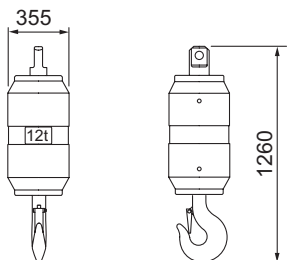
Description	Qty	Dimensions (mm)	Weight (kg)
Jib Base (with Jib Strut)	1		580
Jib Top	1		290
6 m Jib Insert	1		190
100 t Hook	1		1200
50 t Hook	1		1170
35 t Hook	1		900
12 t Hook	1		510

Equipment List

Standard and Optional Equipment

○ : Standard ● : Optional — : No setting

Item		Crane	Clamshell
Lower Structure	810 mm Crawler Shoe	○	○
	Jack Up Unit	○	○
	Crawler Extension / Retraction System	○	○
	Steps	○	○
	Shoe Tension Unit (Hydraulic)	●	●
	Low Wear Shoe (Contiguous Surface of Roller)	●	●
Upper Structure	Cab Up / Down Catwalk	○	○
	Upper House Handrails (for Catwalk)	○	○
	Under Cover (Bed Lower Surface)	○	○
	Working Light (× 2)	○	○
	Back Mirror (Left / Right)	○	○
	Central Lubrication Unit (for Turntable Bearing)	○	○
	Drum Flange Cover	○	○
	Auto Idle Stop	○	○
	Eco Winch	○	○
	Drum Mirror	●	●
	Drum Light (Front Winch)	●	●
	Winch Rope Retainer (Front Winch)	●	●
	Winch Rope Retainer (Rear Winch)	●	●
	Catwalk (Folding Type, Left / Right)	●	●
	Electric Fuel Pump	●	●
	Upper House Handrails (Folding Type)	●	●
Winch with Front and Rear Free Mechanism	●	●	
Third Winch (Rope not Included)	●	-	
Cab	Air Conditioner	○	○
	Sunvisor	○	○
	Sunshade	○	○
	Wiper with Washer (Front Window, Cab Roof Window)	○	○
	Microphone & Loud-speaker	●	●
	AM / FM Radio (with Clock)	○	○
	Room Lamp	○	○
	Cup Holder	○	○
	24 V Power Socket (× 2)	○	○
	Floor Carpet	○	○
	Level Gauge (in Cab & Lower Frame)	○	○
	Accelerator Pedal (Right Side)	●	●
	Arm Chair Lever	○	○
	Cross Operation Lever (Lever Lock not Attached)	●	●
	Front Operation Lever (with Lever Lock)	●	●
	Seat without Suspension	○	○
	Seat with Suspension	●	●
	Travel Operation Pedal (Cannot be installed when winch with free mechanism attached)	●	●
	Boom Hoist Operation Pedal ^{*1}	●	●
	Swing Brake Operation Pedal ^{*1}	●	●
	Fan	●	●
	Front / Rear Operation Lever, Brake Pedal Permutation	●	●
	Fuel Burning Heater	●	●
Accelerator Grip	○	○	
Drum Rotation Sensor (Front / Rear / Boom Hoist) ^{*2}	○	○	
Speed Control Dial (Front / Rear/Boom Hoist / Swing)	○	○	
Life Hammer	○	○	

*1 Cannot be installed at the same time.

*2 Cannot be equipped when the cross operation lever or front operation lever is installed.

○ : Standard ● : Optional — : No setting

Item		Crane	Clamshell	
Attachment	12 m Basic Boom (Boom Base: 6 m, Top: 6 m)	○	○	
	3 m Boom Insert	●	●	
	6 m Boom Insert	●	●	
	9 m Boom Insert	●	●	
	Parts Set for 10 m Crane Jib [10 m Basic Jib, Anti-two Block, Jib Mast]	●	-	
	6 m Crane Jib Insert	●	-	
	Parts Set for Auxiliary Sheave [Auxiliary Sheave, Auxiliary Sheave Anti-two Block]	●	-	
	100 t Hook (4 Sheaves)	●	-	
	50 t Hook (3 Sheaves)	●	-	
	35 t Hook (1 Sheave)	●	-	
12 t Hook	●	-		
Wire Rope	Front Winch (φ 26)	P · S (19) + 39XP · 7	●	-
		IWRC 6 X WS (31)	-	○ ^{*4}
	Rear Winch (φ 26)	Mono Rope EP 3XF (40)	●	-
		P · S (19) + 39XP · 7	●	-
		IWRC 6 X P · WS (31)	-	○ ^{*5}
	Third Winch (φ 26)	Mono Rope EP 3XF (40)	●	-
		P · S (19) + 39XP · 7	●	-
Boom Hoist Winch (φ 22.4)	IWRC 6 X P · WS (31)	○	○	
Safety Device	Moment Limiter	○	○	
	3 Color Percentage Indicator Light	●	●	
	Gate Lock Lever	○	○	
	Individual Operation Lever Lock (Front, Rear, Hoist, Travel) ^{*3}	○	○	
	Automatic Drum Lock (Boom Hoist)	○	○	
	Winch Drum Lock (Front/Rear)	○	○	
	Swing Lock	○	○	
	Swing Alarm	○	○	
	Travel Alarm	○	○	
	Auto Slowdown (Slow Stop)	○	○	
	Boom Hoist Limiting Device	○	○	
	Secondary Boom Over Hoist Prevent Device	○	○	
	Warning Alarm	○	○	
	Monitor Panel (Machine Monitoring)	○	○	
	Engine Start Interlock System	○	○	
	Emergency Engine Stop Switch (In cab)	○	○	
	Lifting Height Indication Device	○	○	
	Anti-two Block Device	○	-	
	Moment Limiter (M/L) Mode Selector (In Left House)	●	○	
	Swing Restriction Unit	●	●	
	Lowering Limiter	●	●	
	Anemometer	●	-	
Obstacle Lights (Fixed lights)	●	-		
Drum and Rear View Monitor System (3 Cameras)	●	●		
Cab Roof Window Guard	●	●		

*3 An operation lever lock is not attached to the front, rear or hoist when the cross operation lever is installed.

*4 Used for opening/closing rope. 82 m length rope required for 12 m digging depth with 21 m boom length.

*5 Used for supporting rope. 70 m length rope required for 12 m digging depth with 21 m boom length.

○ : Standard ● : Optional — : No setting

Item		Crane	Clamshell	
Common parts	Boom Back Stop	○	○	
	Boom Angle Sensor	○	○	
	Boom Lifting Piece	○	○	
	Assembly Pad ^{*6}	●	-	
	Skywalk (with Stanchion)	●	-	
	Skywalk (without Stanchion)	●	-	
	Boom Top Under Surface Buffer (Protector)	●	●	
	Load Table Sign (Whiteboard, Boom Base Installation)	●	●	
	Insertable Company Name Plate (Both Side Surfaces of the Machine)	● ^{*7}	●	
	Opening / Closing / Support Rope Stopper	-	○	
	Hyd. Tagline (6 × Fi (29) φ 10 mm × 55 m)	● ^{*8}	○	
	Reeving Winch (4 × F (30) φ 8 mm × 250 m)	● ^{*8}	-	
	Reeving Winch Cum Hydraulic Tagline	for Hydraulic Tagline (6 × Fi (29) φ 10 mm × 55 m) for Reeving (6 × Fi (29) φ 10 mm × 220 m)	● ^{*8}	-
	Reduction Counterweight Specification			
	Sling Ropes for Disassembly and Assembly (for Counterweights, Crawlers)	●	●	
	Air Cleaner Single Element	○	○	
	Air Cleaner Double Element	●	●	
	Additional Fuel Filter (Triple Filter)	●	●	
	Additional Spare Parts (Hydraulic Oil Filter)	●	●	
	Additional Tools (Large Hammer, Crowbar, Chisel)	●	●	
Other	Standard Supplied Tools	○	○	
	Standard Spare Parts	○	○	

*6 The assembly pad is required for the following attachments.

- Crane Boom Length 51 m + Crane Jib 28 m

*7 When it chooses, the width at the time of transportation is set to not less than 3 m.

*8 (1) Hydraulic tagline (maximum line pull: 2.9 kN (300 kg))

(2) Reeving winch unit (maximum line pull: 11.8 ZkN (1,200 kg))

(3) Reeving winch and hydraulic tagline

(Line pull: For hydraulic tagline (maximum line pull: 1.5 kN (150 kg)) /for reeving winch (maximum line pull: 2.9 kN (300 kg))

*9 The reduction counterweight specification can only be used for the crane specification, with the exception of the crane jib.

Dotted lines for writing content.

Horizontal dashed lines for writing.

A series of horizontal dashed lines for writing, spanning the width of the page.

- We are constantly improving our products and therefore reserve the right to change designs and specifications without notice.
- Units in this specification are shown under International System of Units; the figures in parenthesis are under Gravitational System of Units as old one.

Hitachi Sumitomo Heavy Industries Construction Crane Co.,Ltd.

9-3, Higashi-Ueno 6-chome, Taito-ku, Tokyo 110-0015, Japan
Phone: 81-3-3845-1386 Facsimile: 81-3-3845-1394

<http://www.hsc-crane.com>