

---

Manual # 99905833

# Model 12916 Crane Parts & Specifications

Effective August 2014



IOWA MOLD TOOLING CO., INC.

PO Box 189

Garner, IA 50438

Tel: 641-923-3711 FAX: 641-923-2424

Website: <http://www.imt.com>

Copyright © 2014 Iowa Mold Tooling Co., Inc.  
All rights reserved

No part of this publication may be reproduced, stored in a retrieval system, or transmitted in any form or by any means, electronic, mechanical, photocopying, recording or otherwise without the prior written permission of Iowa Mold Tooling Co., Inc.

Iowa Mold Tooling Co., Inc. is an Oshkosh Corporation Company.



# Contents

Revisions .....	iii
<b>Introduction</b>	<b>5</b>
<b>Specifications</b>	<b>7</b>
Model 12916 Specifications .....	8
Geometric Configuration .....	10
Minimum Chassis Specifications for 12916 Crane .....	12
<b>Reference</b>	<b>13</b>
Major Crane Assemblies .....	14
Weldment Part Number Locations .....	14
Grease Zerk Locations & Lubricant Requirements .....	15
Installation .....	16
<b>Parts</b>	<b>19</b>
Parts Information .....	20
Base & Out Assembly (40725982).....	22
Stabilizer Cylinder (3C283801).....	26
Mast Assembly (40725983).....	27
Inner Boom Assembly (40725984) .....	28
Inner Cylinder (3C194614).....	29
Outer Boom Assembly (40725985).....	30
Outer Cylinder (3C195613).....	32
Extension Boom Assembly (40725986) .....	33
Extension Cylinder (51718065).....	34
Hydraulic Diagram, Radio Remote (99905792).....	36
Hydraulic Diagram, Radio Remote (99905792).....	38
Relief Valve Assembly, 12V Radio (73055278).....	39
Control Kit – Manual 8 Function (90704441).....	40
Valvebank Assembly – 8 Section (51706642).....	42
Valvebank Assembly – 8 Section (51706643).....	43
Hydraulic Kit – 6 Section (91703946).....	44
Hydraulic Overload Kit, 3-Function (51717130) .....	46
Electrical Control Cabinet (41718269-12V, 41718425-24V).....	48
Electrical Control Box Assembly (41718269-12V, 41718425-24V) .....	50
Relay Fuse Box, 12V & 24V (77044935) .....	52
Radio Remote .....	53
Installation Kit-Manual Controls (93708876) .....	54
Decal Kit (95712299) .....	56
Capacity Alert Kit – 2800 PSI (31717169) .....	58
Capacity Shutdown Kit – 2800 PSI (31717514).....	58
Light Kit – Crane Mast Mounted (51717977) .....	59
Hydraulic Shutdown Kit (31713788) .....	61

Option – Hook Assembly Kit (40726070).....63  
12916 Recommended Spare Parts List .....64

---

**General Reference** **65**

---

Inspection Checklist .....65  
Deficiency / Recommendation / Corrective Action Report .....70  
Turntable Bearing Thread Tightening Sequence .....75  
Turntable Bearing Inspection .....76  
Thread Torque Chart (English).....78  
Thread Torque Chart (Metric) .....79

---

## Revisions

DATE	LOCATION	DESCRIPTION



---

## CHAPTER 1

# Introduction

This volume deals with information applicable to your particular crane. For operating, maintenance and repair instructions, refer to Volume 1, OPERATION, MAINTENANCE AND REPAIR.

We recommend that this volume be kept in a safe place in the office.

This manual is provided to assist you with ordering parts for your IMT crane. It also contains additional instructions regarding your particular installation.

In addition to reading the manual, it is your responsibility to become familiar with government regulations, hazards, and the specific operation of your equipment. Use caution and common sense while operating and maintaining the equipment and follow all safety procedures and regulations. Treat this equipment with respect and service it regularly.

### MODIFICATIONS

Modifications to your equipment must be performed with IMT approved accessories, parts and optional equipment. If in doubt, contact IMT prior to making any modifications. DO NOT alter or modify any safety device! All safety devices must be inspected, tested and maintained in proper working condition.

Decals regarding safety and operation are considered safety equipment, and must be kept clean and legible.

The equipment owner and/or designated employee is responsible for informing all operators, maintenance personnel, and others involved in equipment operation about the safe operation and maintenance of the equipment. If questions arise concerning safe operation, contact IMT or your IMT distributor for clarification.

### WARRANTY

Warranty of this unit will be void on any part of the unit subjected to misuse due to overloading, abuse, lack of maintenance and unauthorized modifications. No warranty - verbal, written or implied - other than the official, published IMT new machinery and equipment warranty will be valid with this unit.

### NOTICE TO THE OWNER / USER

If your equipment is involved in a property damage accident, contact your IMT distributor immediately and provide them with the details of the accident and the serial number of the equipment. If an accident involves personal injury, immediately notify your distributor and IMT Technical Support at:

IOWA MOLD TOOLING CO., INC.

500 HWY 18 WEST

GARNER, IA 50438

641 - 923 - 3711

## RESPONSIBILITY

It is the user's responsibility to maintain and operate this unit in a manner that will result in the safest working conditions possible. In addition, it is the user's responsibility to be aware of existing Federal, State, and Local codes and regulations governing the safe use and maintenance of this equipment.

## MANUAL STRUCTURE

Throughout this manual, three means are used to draw the attention of personnel. They are NOTES, CAUTIONs and WARNINGs and are defined as follows:

### **NOTE**

A NOTE is used to either convey additional information or to provide further emphasis for a previous point.

### **CAUTION**

A CAUTION is used when there is the very strong possibility of damage to the equipment or premature equipment failure.

### **WARNING**

A WARNING is used when there is the potential for personal injury or death.



## CHAPTER 2

# Specifications

## In This Chapter

Model 12916 Specifications .....	8
Geometric Configurations .....	10
Minimum Chassis Specifications .....	12

## Model 12916 Specifications

GENERAL SPECIFICATIONS	
<b>*CRANE RATING (ANSI B30.22)</b>	129,000 FT-LBS
<b>*MAXIMUM CRANE RATING</b>	129,000 FT-LBS
<b>HORIZONTAL REACH</b> from centerline of rotation	16'-2"
<b>HYDRAULIC EXTENSION</b>	40"
<b>MANUAL EXTENSION</b>	NONE
<b>VERTICAL REACH</b> from mounting surface	23'-1"
<b>VERTICAL REACH</b> from ground/41" frame ht.	26'-6"
<b>CRANE WEIGHT</b>	6,040 LBS
<b>STABILIZER SPAN</b>	15'-0"
<b>STABILIZER PADS</b>	12" X 19"
<b>CRANE STORAGE HEIGHT</b> from mounting surface	8'-2"
<b>CRANE STORAGE HEIGHT</b> from ground/41" frame ht.	11'-7"
<b>**MOUNTING SPACE REQUIRED</b>	32"
<b>ROTATIONAL TORQUE</b>	16,200 FT-LBS
<b>OPTIMUM PUMP CAPACITY</b>	13 U.S. GPM
<b>SYSTEM OPERATING PRESSURE</b>	2300 PSI
<b>OIL RESERVOIR CAPACITY</b>	21 U.S. GALLONS
<b>HOOK APPROACH-HORIZONTAL</b> from centerline of rotation	5'-10"
<b>HOOK APPROACH-VERTICAL</b> from mounting surface	9'-8"

\* Maximum Crane Rating (ft-lbs) is defined as that rated load (lbs) which when multiplied by its respective distance (ft) from centerline of rotation gives the greatest ft-lb value.

ANSI B30.22 Crane Rating (ft-lbs)= With all extensions retracted and inner plus outer boom in a horizontal position, rated load (lbs) X respective distance (ft) from centerline of rotation = nominal ft-lb value.

\*\* Allow an additional 3" between the cab and crane base for swing clearance.

IMT reserves the right to change specifications and design without notice. Where applicable, specifications are in accordance with SAE standards and ISO/DIS 3691-1, the international standard for Industrial Trucks - Safety Requirements and Verification.

IOWA MOLD TOOLING CO., INC.

BOX 189, GARNER, IA 50438-0189

TEL: 641-923-3711 FAX: 641-923-2424

PERFORMANCE CHARACTERISTICS		
	SPECIFICATIONS	SPEED
CRANE ROTATION WITH TIREHAND	370°	45 seconds
INNER BOOM ELEVATION	-23° to +67°	25 seconds
OUTER BOOM ARTICULATION	112°	19 seconds
EXTENSION BOOM	40"	6 seconds
STABILIZER EXTENSION	29-1/4"	40 seconds

#### POWER SOURCE

Integral-mounted hydraulic pump and PTO application. Other standard power sources may be utilized—minimum power required is 21 horsepower.

#### CYLINDER HOLDING VALVES

The holding sides of all cylinders are equipped with integral-mounted holding or counter-balance valves to prevent sudden cylinder collapse in case of hose or other hydraulic failure. The stabilizer cylinders have positive, pilot-operated holding valves that open only on command.

The inner cylinders have single pilot-operated counter balance valves while the outer and extension boom cylinders have double counter-balance valves. The counter-balance valve serves several functions. First, it is a holding valve. Secondly, it is so constructed that it will control the lowering function and allow that motion to be feathered while under load. Finally, if a hose breaks, the only oil loss will be that in the hose.

#### ROTATION SYSTEM

Rotation of the crane is accomplished through a turntable bearing, powered by a high torque hydraulic motor through a ring and pinion type spur gear train. Total gear reduction is 56.7 : 1.

#### HYDRAULIC SYSTEM (PTO DRIVEN)

The hydraulic system is an open-centered, full-pressure system that requires 13 GPM optimum oil flow at 2300 PSI. Eight-spool, stack-type control valve, six of which are used for the standard crane and the remaining two are plugged, but easily adapted for additional optional features. Dual operational handles for six functions are located at both sides of the crane for convenient operation. System includes hydraulic oil reservoir, suction-line strainer, pump, 8-section control valve, return-line filter and all hoses and fittings.

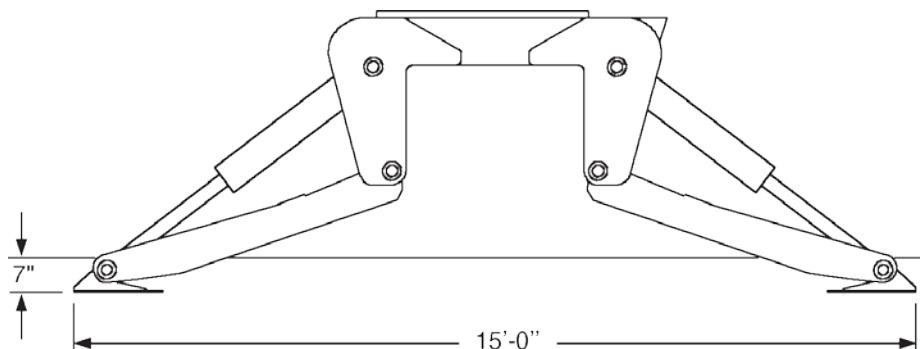

STABILIZER DIMENSIONS

# Geometric Configuration

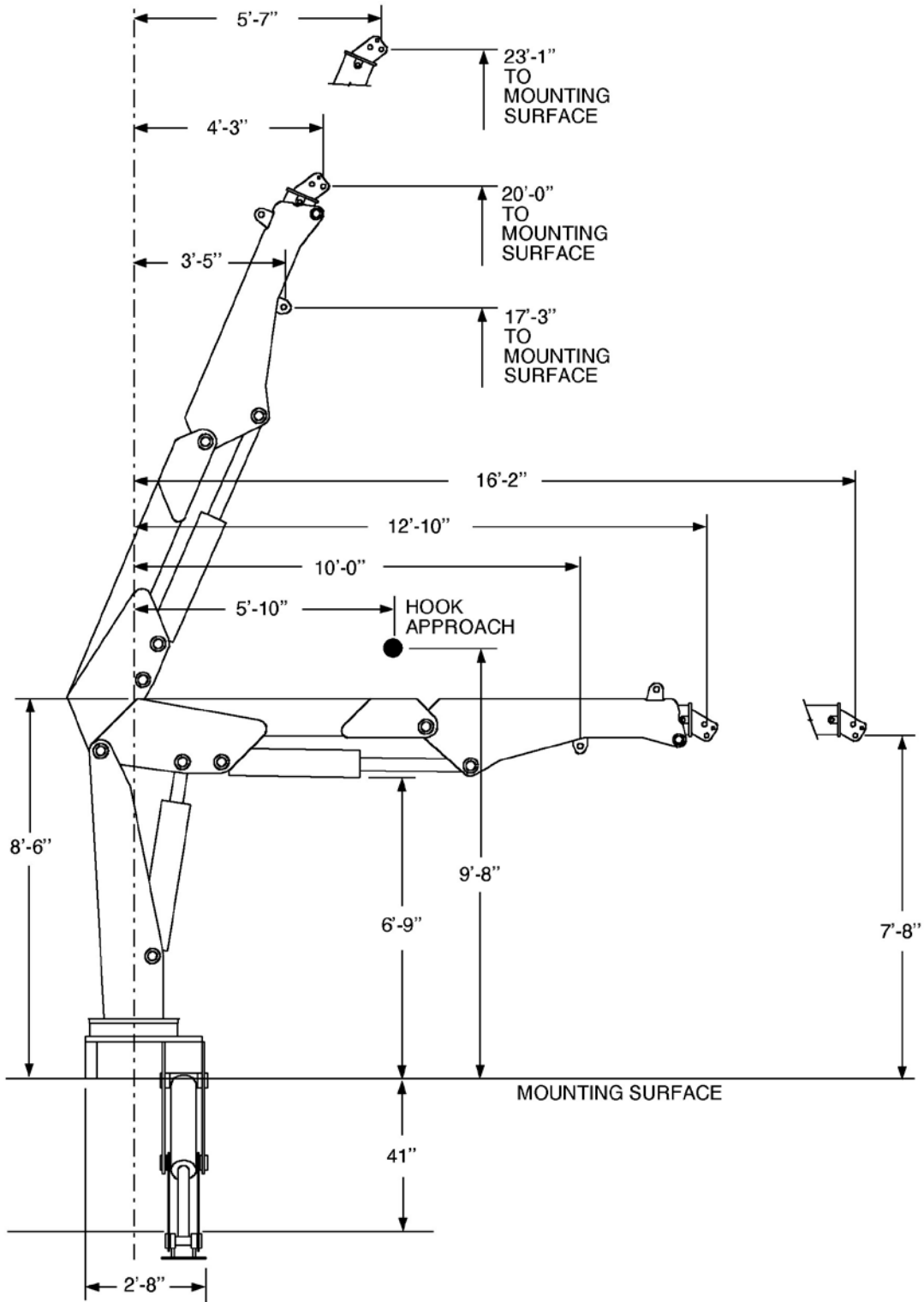

IOWA MOLD TOOLING CO., INC. ● BOX 189 ● GARNER ● IA ● 50438 ● 641-923-37 11  
 Capacities through geometric range are limited to those shown in horizontal position.



**MODEL  
12916  
CRANE**

- Loads shown are based on crane structural or hydraulic capability. Before lift is made, stability must be checked per SAE J765A.
- Working loads will be limited to those shown. Deduct the weight of load handling devices.
- Winch lifting capacity is limited to those shown - Maximum 4000 LBS for 1-part line.

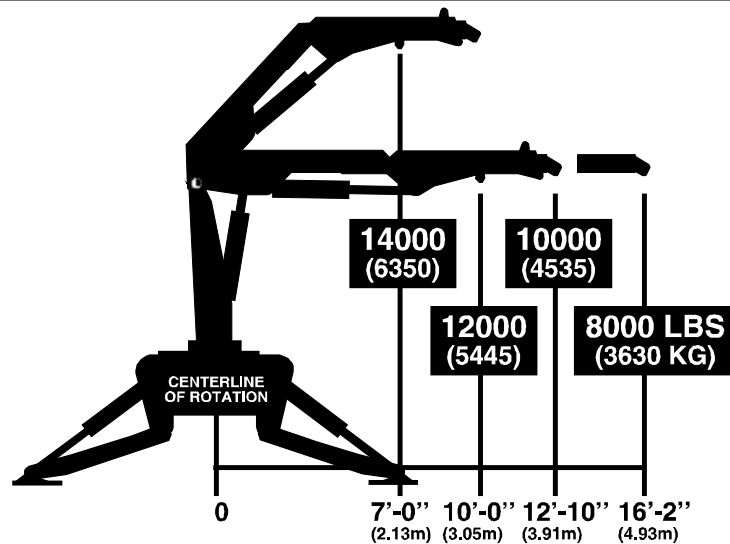
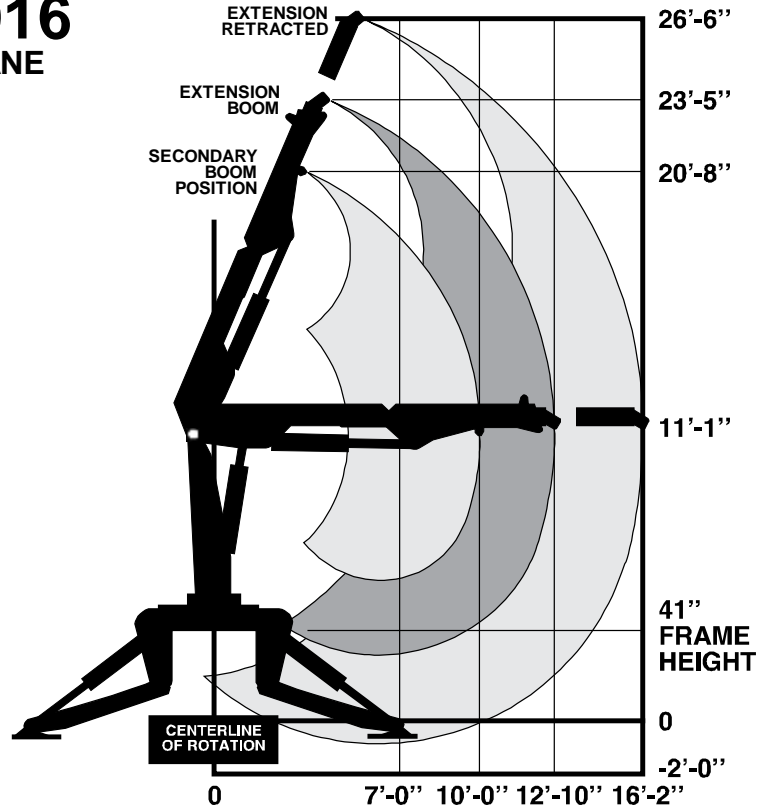

71393869

# Minimum Chassis Specifications for 12916 Crane

CRANE MOUNT	Behind Cab
CRANE WORKING AREA	360°
CHASSIS STYLE	Conventional Cab
FRONT AXLE RATING (GAWR)	12,000 lbs
REAR AXLE RATING (GAWR)	Single Axle 21,000 lbs
WHEELBASE	207"
CAB-TO-AXLE	138"
OUTRIGGER WIDTH REQUIRED	15'-0"
RBM Frame Selection Modules Frame Yield Strength	1,664,000 in-lbs 26 cubic inches 50,000 psi
MINIMUM FINISHED UNIT WEIGHT TO MAINTAIN VEHICLE STABILITY Front Axle Rear Axle Total Finished Unit Weight	* 8,400 lbs *11,400 lbs 19,800 lbs

\*Allows lifting full capacity load in a 360° arc when crane is installed immediately behind the cab. Great care should be taken when swinging the load from rear of vehicle to front of vehicle since the front axle springs will compress, thus affecting the levelness of the vehicle.

**FIGURE A.  
360° WORKING AREA**

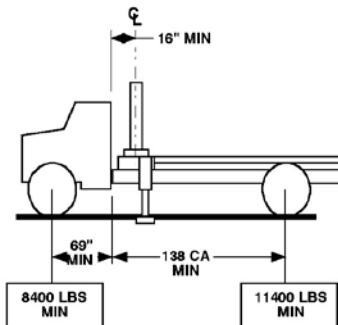

**NOTES:**

- 1 GAWR means Gross Axle Weight Rating and is dependent on all components of the vehicle such as axles, tires, wheels, springs, brakes, steering and frame strength meeting the manufacturer's recommendations. Always specify GAWR when purchasing a truck.
- 2 Minimum axle requirements may increase with use of diesel engines, longer wheelbase or service bodies. Contact the factory for further information.
- 3 Weight distribution calculations are required to determine final axle loading.
- 4 All chassis and crane combinations must be stability tested to ensure stability per ANSI B30.22.

## CHAPTER 3

# Reference

## In This Chapter

Major Crane Assemblies .....	14
Weldment Part Number Locations .....	14
Grease Zerk Locations & Lubricant Requirements .....	15
Installation .....	16
Crane Mounting .....	16
Hydraulic Installation .....	16

---

## Major Crane Assemblies

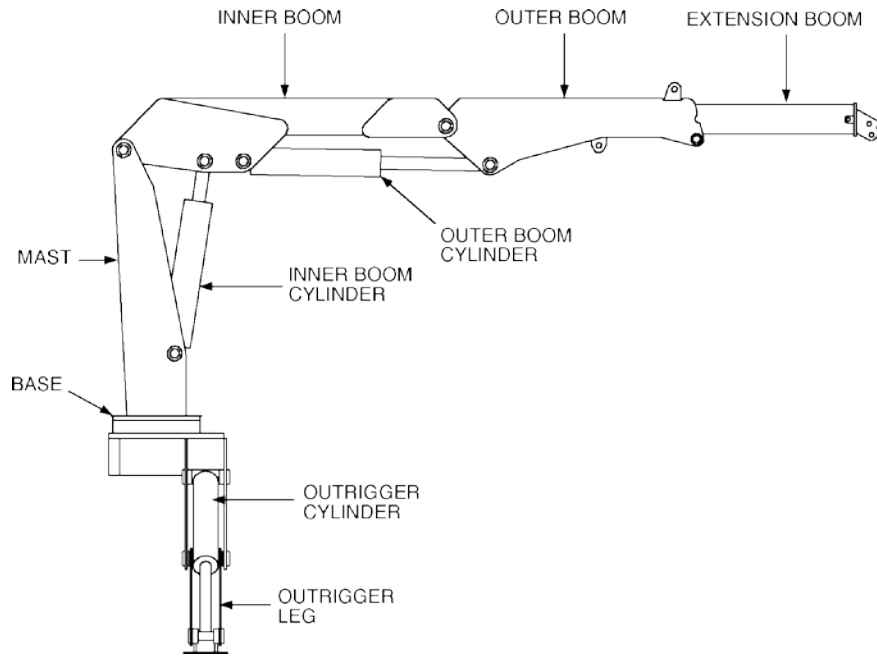

---

## Weldment Part Number Locations

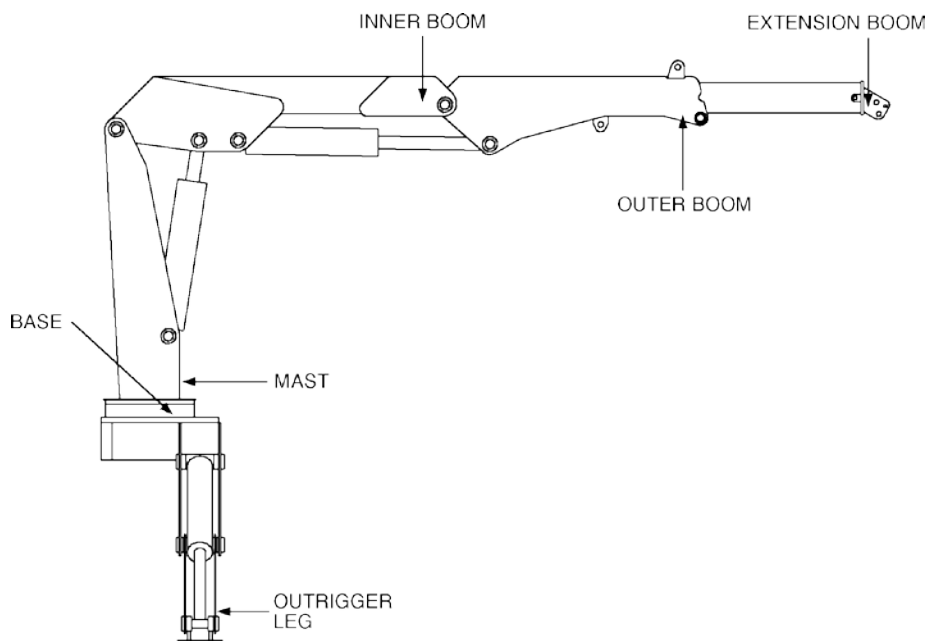



# Grease Zerk Locations & Lubricant Requirements

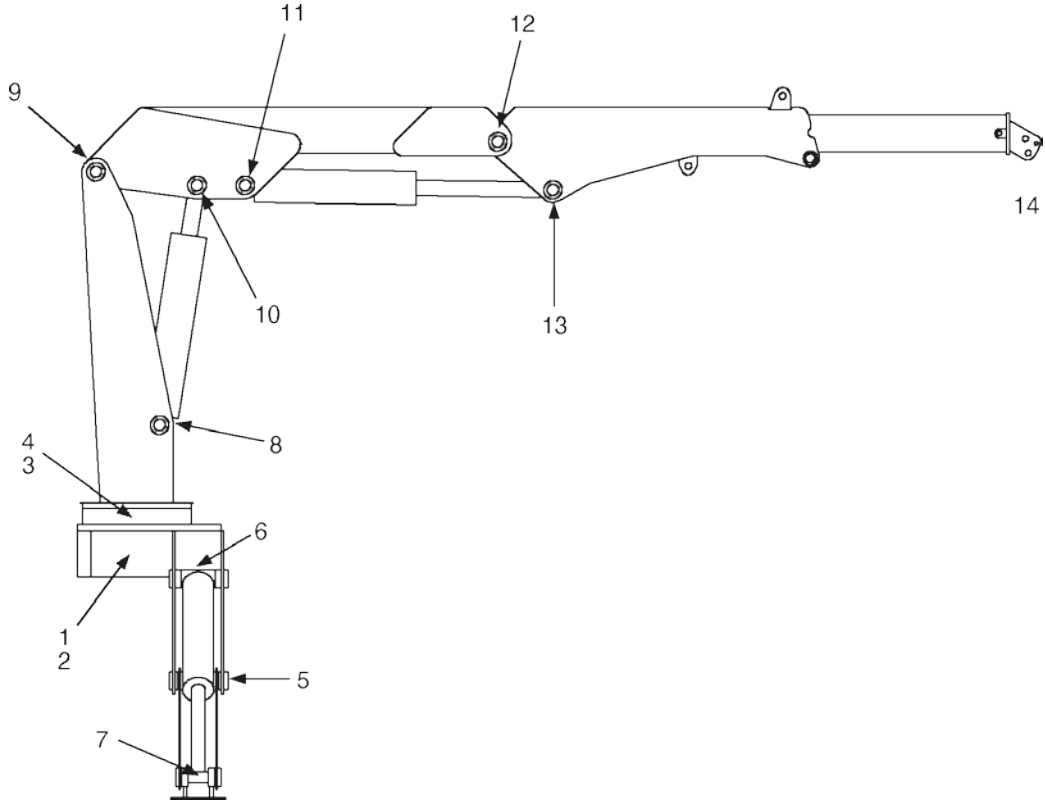

ITEM	LOCATION DESCRIPTION	LUBRICANT	FREQUENCY
1.	TURNTABLE/BEARING GREASE EXTENSION	SHELL ALVANIA 2EP  OR  SHELL RETINAX "A"	WEEKLY
2.	*ROTATE CRANE WHILE GREASING DRIVE GEAR		
3.	GREASE EXTENSION PINION		
4.	GEAR		
5.	PINION COVER		
6.	BASE/STABILIZER LEG HINGE		
7.	PIN STABILIZER CYLINDER		
8.	BASE STABILIZER CYLINDER		
9.	ROD INNER CYLINDER BASE		
10.	MAST/INNER BOOM HINGE		
11.	PIN INNER CYLINDER ROD		
12.	PIN OUTER CYLINDER BASE		
13.	INNER BOOM/OUTER BOOM HINGE		
14.	PIN OUTER CYLINDER ROD		
	ANY TIREHAND ATTACHMENT		

**NOTE:** All application points must be greased weekly under normal workloads and moderate weather conditions. Under severe operating conditions, lubrication should be performed more frequently. See Volume 1; Operation, Maintenance and Repair for additional lubrication requirements.

---

# Installation

## GENERAL

This section contains specific instructions for the installation of your crane. Prior to installing the crane and hydraulic components, make sure the chassis is ready to receive the crane (refer to Volume 1, Installation).

## CRANE MOUNTING

1. See SPECIFICATIONS in Section 1 for crane weight. Using an overhead hoist and fabric slings of adequate capacity, lift the crane about a foot to see if the crane is adequately balanced. If not, lower hoist and adjust slings. Re-check the balance and reposition crane until mounting surface is level.
2. Install the truck frame support so that the tie-down studs pass through the supports (Figure below). Cut the support to the inside dimensions of the truck frame. Allow about 1/16" extra. Grind the end of the support to fit inside the frame channel. Use a hammer to drive it into position if necessary.
3. Allow sufficient clearance between the cab and crane base, at least 3" (7.6cm). Position the crane on the chassis per the applicable installation drawing, centering the mounting slots over the truck frame rails. While holding crane with hoist, start mounting hardware per Figure. Note position of support weldments on truck frame. Hand-tighten nuts. Observe underside of crane base. No clearance between base and frame is allowed.
4. Torque the 1 1/4"-7 UNC Grade 5 mounting hardware to 840 ft-lbs (116 kg-m). When torquing the mounting hardware the following precautions must be followed.
  - a. Never use lock washers.
  - b. Hardened washers must be used, and under the turning element, whether the turning element is the nut or the head of the bolt.
  - c. Torque values specified are with residual oils or without special lubricants applied to the threads. If special lubricants are used, such as Never-Seize compound graphite and oil, molybdenum disulphite colloidal copper or white lead, reduce torque values 10%. Torque values for threaded fasteners are not affected with the use of Loctite.
  - d. Do not use rusty fasteners, the rust will alter torque values significantly.

### CAUTION

Do NOT attempt to apply the same torque to the tie rod and self-locking nuts as shown in the torque data chart. Do NOT exceed 840 ft-lb (116 kg-m). Exceeding this torque value could damage either the chassis or crane base.

Power wrenching is not recommended until the lead thread of the nut insert is engaged by hand turning.

5. Install the tie-plate (Figure C-1) on the truck chassis. Drill four holes using the plate as a template and install the bolts and lock nuts. Torque the bolts to 200 ft-lbs (28 kg-m). Weld the tie-plate to the crane base with 3/8" continuous fillet weld.
6. Install the two tension bars with nuts and washers as shown. Tighten the outside nuts first to about 200 ft-lbs (28 kg-m) to preload the tension bar. Then tighten the inner nuts to 466 ft-lbs (65 kg-m).
7. Touch up paint on crane and chassis as necessary.

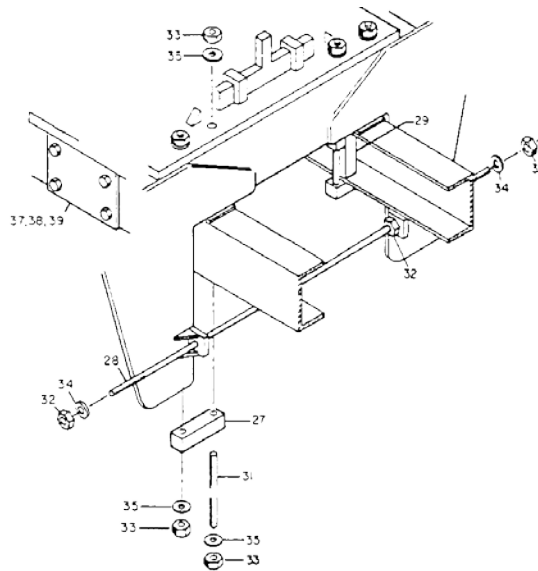

ITEM	DESCRIPTION	ITEM	DESCRIPTION
27.	CLAMP BLOCK	33.	LOCK NUT
28.	TENSION BAR	34.	LOCK WASHER
29.	FRAME SUPPORT	35.	WASHER
31.	TIE-DOWN STUD	37.	TIE-PLATE
32.	NUT	38.	CAP SCREW
		39.	LOCK NUT

### CRANE INSTALLATION

#### HYDRAULIC INSTALLATION

To install the hydraulic hoses, fittings, etc.:

1. Plumb the suction line filter as shown in Figure below.
2. Install the suction hose between the suction line filter and the pump inlet. Tighten the hose clamps.
3. Install the pressure hose between the pump outlet and the inlet port on the valvebank.
4. Install the return line between the reservoir return line filter and valvebank (if applicable).
5. Fill the hydraulic oil reservoir.

6. Open the gate valve at the suction-line filter.

**CAUTION**

Failure to open the gate valve will result in a dry running pump which may damage the pump.

7. Open the return gate valve.
8. Start the vehicle's engine and engage the PTO. Allow the system to run for about five minutes and then check the vacuum gauge on the suction-line filter (it should read 8" mercury or less). If the vacuum reading is too high, check to make certain that the gate valve is opened completely. If the valve is fully opened, check for a collapsed or restricted suction line.
9. Cycle all hydraulic functions. Check for leaks, and refill the reservoir if necessary.

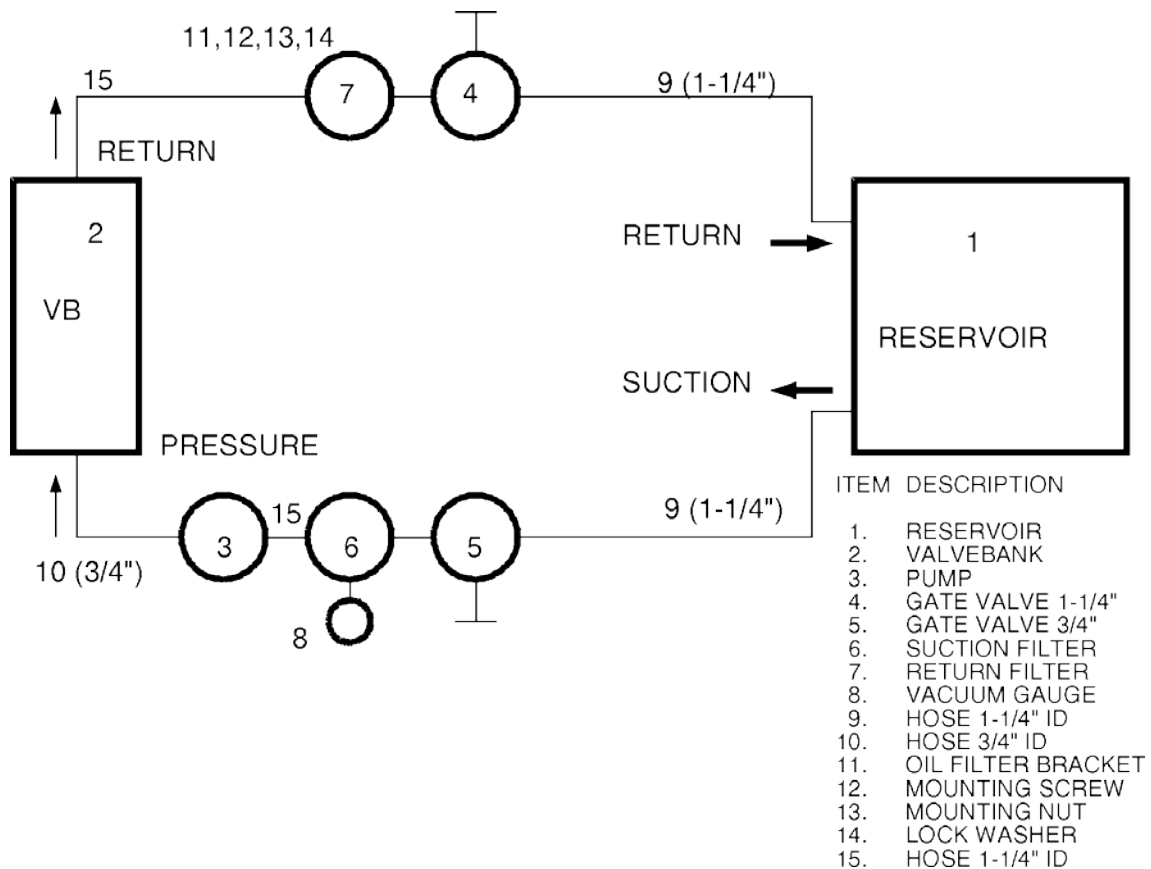

HYDRAULIC INSTALLATION

## CHAPTER 4

## Parts

## In This Chapter

Parts Information .....	20
Base & Out Assembly (40725982).....	22
Stabilizer Cylinder (3C283801) .....	26
Mast Assembly (40725983) .....	27
Inner Boom Assembly (40725984) .....	28
Inner Cylinder (3C194614) .....	29
Outer Boom Assembly (40725985).....	30
Outer Cylinder (3C195613).....	32
Extension Boom Assembly (40725986).....	33
Extension Cylinder (51718065).....	34
Hydraulic Diagram, Radio Remote (99905792) .....	36
Relief Valve Assembly .....	39
Control Kit – Manual 8 Function (90704441).....	40
Relief Valve Assembly .....	39
Valvebank Assembly – 8 Section (51706642).....	42
Valvebank Assembly – 8 Section (51706643).....	43
Hydraulic Kit – 6 Section (91703946) .....	44
Hydraulic Overload Kit, 3-Function (51717130) .....	46
Electronic Control Cabinet .....	48
Electronic Control Box Assembly.....	50
Relay Fuse Box (77044935) .....	52
Radio Remote .....	53
Installation Kit-Manual Controls (93708876) .....	54
Decal Kit (95712299).....	56
Capacity Alert Kit – 2800 PSI (31717169) .....	58
Capacity Shutdown Kit – 2800 PSI (31717514).....	58
Light Kit – Crane Mast Mounted (51717977) .....	59
Hydraulic Shutdown Kit (31713788) .....	61
Option – Hook Assembly Kit (40726070) .....	63
Recommended Spare Parts List .....	64

## Parts Information

### GENERAL

This section contains the exploded parts drawings, with accompanying parts lists, for the assemblies used on this crane. These drawings are intended to be used in conjunction with the instructions found in the REPAIR section in Volume 1. For optional equipment such as winches and remote controls, refer to the appropriate service manual.

<b>⚠ WARNING</b>
<p>Do not attempt to repair any component without reading the information contained in the repair section. Pay particular attention to statements marked Warning, Caution or Note in that section. Failure to comply with these instructions may result in damage to the equipment, personal injury or death.</p>

### CRANE IDENTIFICATION

Every IMT crane has an identification placard (see figure). This placard is attached to the inner boom, mast, or crane base. When ordering parts, communicating warranty information, or referring to the unit in correspondence, always include the serial number and model numbers. Address all inquiries to your authorized IMT distributor or to:

Iowa Mold Tooling Co., Inc.  
 Box 189, Garner, IA 50438-0189  
 Telephone: 641-923-3711  
 Technical Support Fax: 641-923-2424

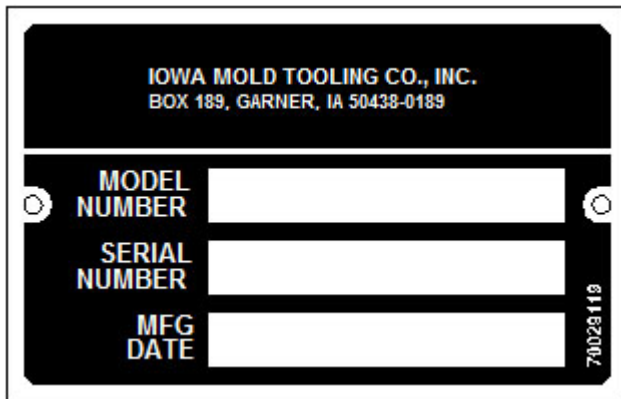

### CYLINDER IDENTIFICATION

To insure proper replacement parts are received, it is necessary to specify the complete number/letter sequence for any part requested. Part numbers may be cross checked by comparing the stamped identification on the cylinder case (See figure) against the information contained in the service manual. You must include the part number stamped on the cylinder case when ordering parts.

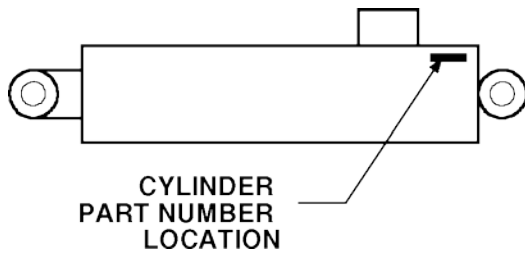

### WELDMENT IDENTIFICATION

Each of the major weldments – base, mast, inner boom, outer boom, extension boom and stabilizer weldments bear a stamped part number. Any time a major weldment is replaced, you must specify the complete part number as stamped on the weldment. The locations of the part numbers are shown in Chapter 2.

### ORDERING REPAIR PARTS

When ordering replacement parts:

- 1 Give the model number of the unit.
- 2 Give the serial number of the unit.
- 3 Specify the complete part number. When ordering cylinder parts, or one of the main weldments, always give the stamped part number.
- 4 Give a complete description of the part.
- 5 Specify the quantity required.

# Base & Out Assembly (40725982)

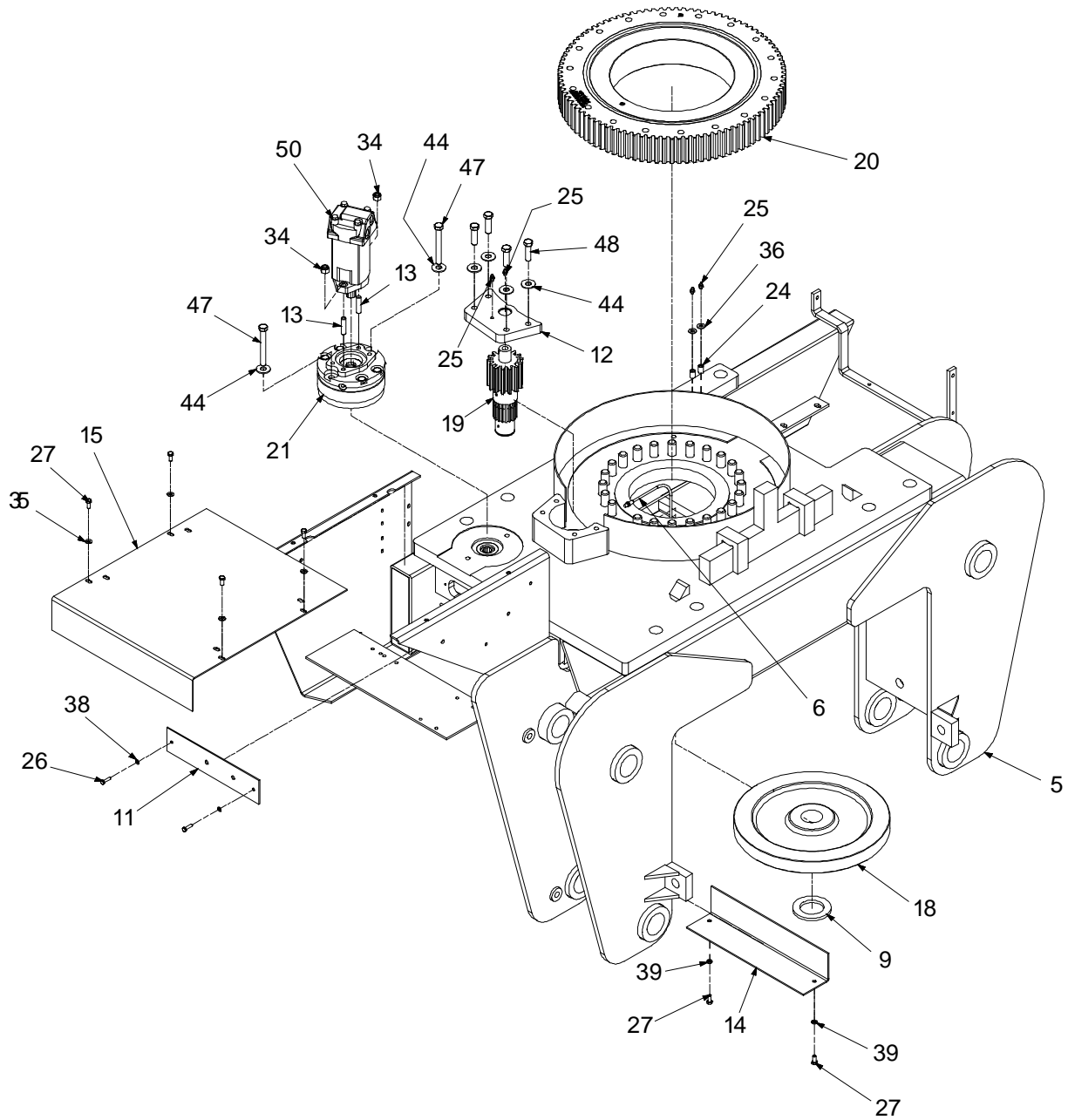



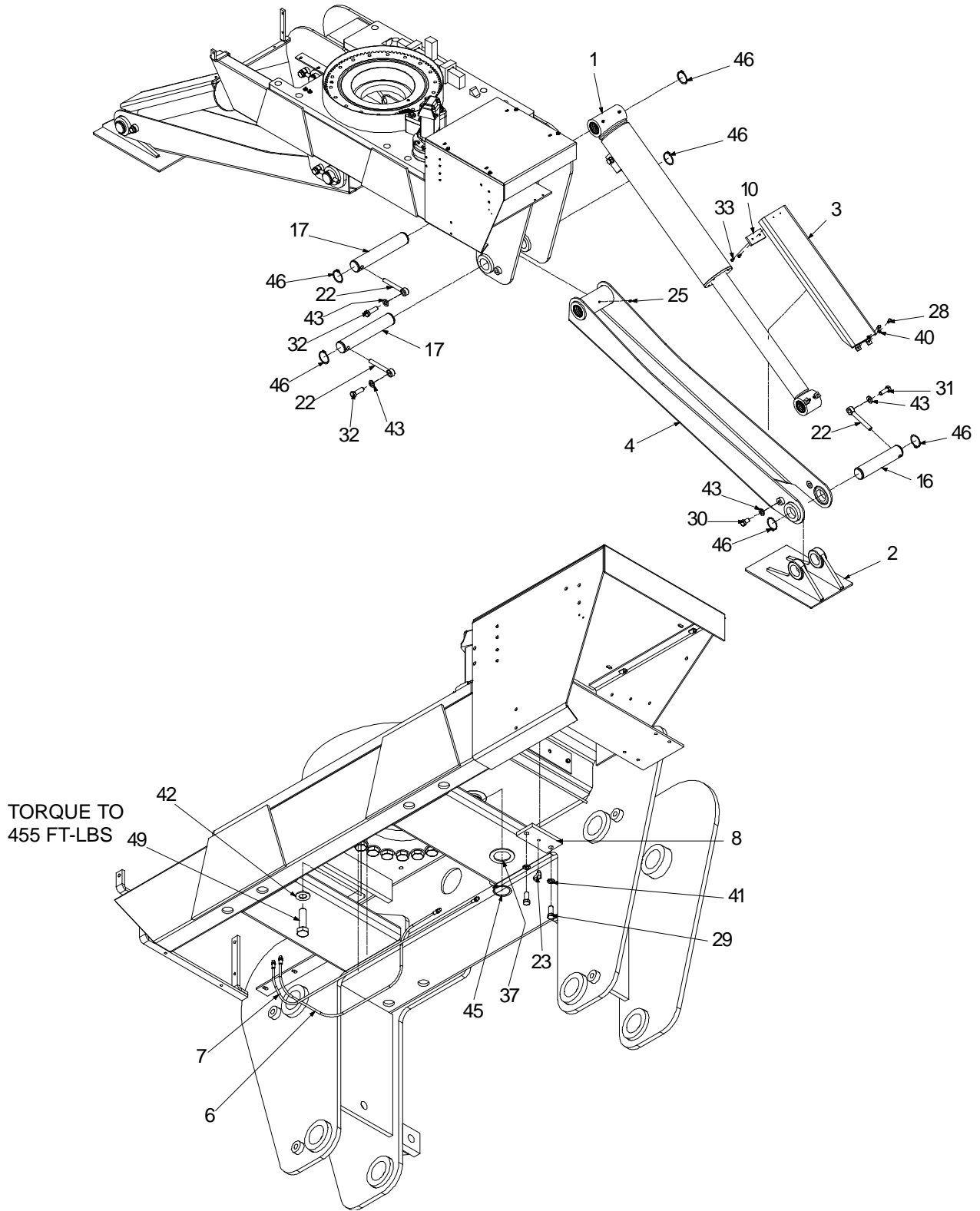

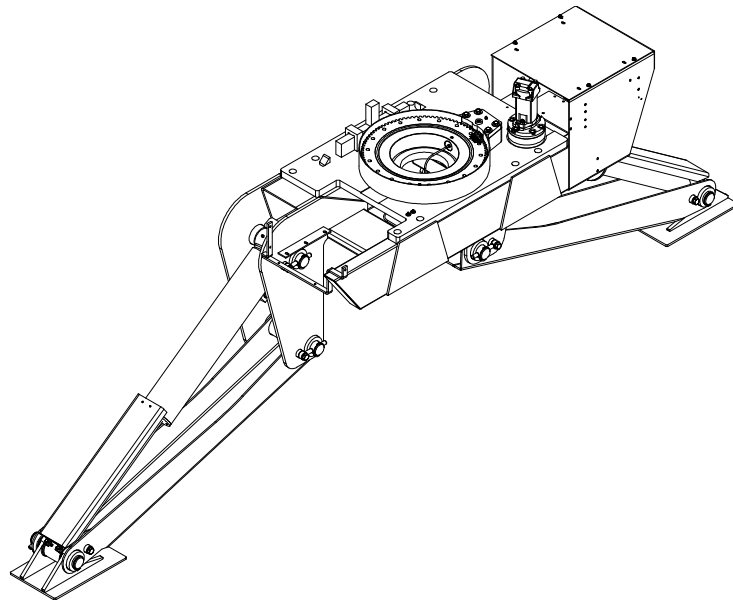

NOTE:

- 1 APPLY LUBRICANT TO THE EXTERNAL TEETH OF THE TURNTABLE BEARING AND PINION GEAR.
- 2 TURNTABLE BEARING BACKLASH – 0.008/0.013.

40725982 PARTS LIST				
ITEM	PART #	DESCRIPTION	KIT	QUANTITY
1.	3C283801	CYL-6.0/3.0 29.25S 42.12CC C		2
2.	52701412	OUTRG PAD-MACH (CAST EARS) 12916 20017		2
3.	52706739	GUARD-OUTRG CYL ROD 1216		2
4.	52725863	WLDMT-FOLD DOWN STAB LEG 12916		2
5.	52725971	WLDMT-BASE 12916		1
6.	53000710	GREASE EXT-38.00 OAL 36.00 HOSE		1
7.	53000713	GREASE EXT-38.00 OAL 36.00 HOSE		1
8.	60010844	GREASE PLATE-DRIVE GEAR		1
9.	60020123	THRUST WASH-BRZ 2.50X4.00X.31		1
10.	60030176	WEAR PAD-B2 UHMW .50X2.00X4.00		2
11.	60103367	INSPECTION PLATE COVER		1
12.	60105964	SUPPORT PLT-PINION		1
13.	60106032	STUD .50-13X1.75	51	2
14.	60106193	PLANETARY GEAR COVER		1
15.	60118802	VALVE BANK COVER – TOP PLATE		1
16.	60141680	PIN-TYPE PP 2.50X 11.75 (10.03)		2
17.	60141681	PIN-TYPE PP 2.50X 14.50 (12.78)		4
18.	71056072	GEAR-INTMD 301-10051-1		1
19.	71056073	GEAR-PINION 301-10052-1		1
20.	71056273	BEARING-ROTATION		1
21.	71056623	BRAKE-HYD SWING DRIVE		1
22.	71415017	KEEPER-PIN .75		6
23.	72053281	ELBOW-STREET BLK .12X90 DEG		1
24.	72053301	COUPLING-GLV .12 SCH 40		2

40725982 PARTS LIST				
ITEM	PART #	DESCRIPTION	KIT	QUANTITY
25.	72053508	ZERK-NPT .12	51	6
26.	72060004	CAP SCREW .25-20X 1.00 HH GR5 Z	51	2
27.	72060023	CAP SCREW .31-18X .75 HH GR5 Z	51	6
28.	72060044	CAP SCREW .38-16X .75 HH GR5 Z	51	4
29.	72060092	CAP SCREW .50-13X 1.25 HH GR5 Z	51	2
30.	72060182	CAP SCREW .75-10X 1.25 HH GR5 Z	51	2
31.	72060185	CAP SCREW .75-10X 2.00 HH GR5 Z	51	2
32.	72060186	CAP SCREW .75-10X 2.50 HH GR5 Z	51	4
33.	72060836	SCR-MACH .25-20X .75FLH	51	4
34.	72062080	NUT .50-13 HEX NYLOCK	51	2
35.	72063002	WASHER .31 FLAT	51	4
36.	72063003	WASHER .38 FLAT	51	2
37.	72063039	MACHY BUSHING 2.00X10 GA NR	51	1
38.	72063049	WASHER .25 LOCK	51	2
39.	72063050	WASHER .31 LOCK	51	2
40.	72063051	WASHER .38 LOCK	51	4
41.	72063053	WASHER .50 LOCK	51	2
42.	72063115	WASHER .88 FLAT ASTM F436	51	23
43.	72063116	WASHER .75 N FLAT H ASTM F436Z	51	8
44.	72063117	WASHER .56 FLAT ASTM F436	51	6
45.	72066095	RETAINING RING-EXT 2.00 STD	51	1
46.	72066103	RETAINING RING-EXT 2.50 STD		12
47.	72601037	CAP SCR .56-12X 4.50 HH GR8 Z	51	2
48.	72601144	CAP SCR .56-12X 2.00 HH GR8 Z	51	4
49.	72601148	CAP SCR .88-9X 3.00 HH GR8 Z	51	23
50.	73051223	MOTOR-HYD C104-1021 NO DANFOSS		1
51.	91725992	KIT-HRDW BASE 12916		1
NEW 20140421				

# Stabilizer Cylinder (3C283801)

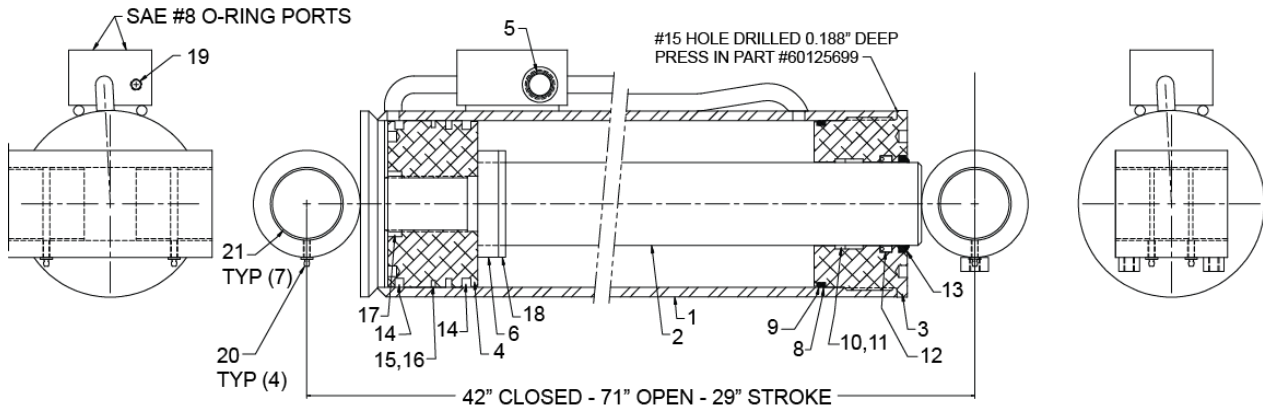

## NOTE:

- 1 IT IS RECOMMENDED THAT ALL COMPONENTS OF THE SEAL KIT BE REPLACED WHENEVER THE CYLINDER IS DISASSEMBLED. THIS WILL REDUCE FUTURE DOWNTIME.
- 2 APPLY "LUBRIPLATE #630.2" MEDIUM HEAVY, MULTI-PURPOSE LUBRICANT OR EQUIVALENT TO ALL PISTON AND HEAD GLANDS, LOCK RING AND ROD THREADS BEFORE ASSEMBLY.
- 3 APPLY "NEVER-SEEZ" OR EQUIVALENT BETWEEN THE HEAD AND THE CASE WHEN ASSEMBLING THE CYLINDER. KEEP AWAY FROM ALL SEALS.

## 3C283801 PARTS LIST

ITEM	PART #	DESCRIPTION	KIT	QTY
1.	4C283801	CASE ASSEMBLY - 6.03B X 39.31L		1
2.	4G283800	ROD ASSEMBLY 3.00X39.31L 2.00S		1
3.	6H060030	HEAD - 6.03B X 3.00R		1
4.	6I060200	PISTON - 6.00B C 2.00S		1
5.	73054304	VALVE - CBAL 10GPM		2
6.	6C075030	STOP TUBE - 3.00R X .75L		1
7.	9C242432	SEAL KIT - IMT 6.00B 3.00R 2.00S		1REF
8.	7Q10P358	BACKUP RING - 5.62 ID X 6.00 OD	7	1
9.	7Q072358	O RING - 5.62 X 6.00 X .19 70	7	1
10.	7T2N4032	WEAR RING - ROD 3.00 ID X .50W	7	1
11.	7T2N8032	WEAR RING - ROD 3.00 ID X .50W	7	1
12.	7R546030	U CUP SEAL - 3.00 X 3.50 X .38	7	1
13.	7R14P030	ROD WIPER - TYPE D 3.00	7	1
14.	7T65I060	PISTON RING - 6.00	7	2
15.	7Q072253	O RING - 5.38 X 5.62 X .12 70	7	1
16.	7T66P060	PISTON SEAL - DYN 6.00	7	1
17.	7T61N200	LOCK RING - NYLON 2.00"	7	1
18.	60138277	STOP TUBE - 3.00R X .25L	7	1
19.	7PNPXT02	PIPE PLUG .125NPT (PART OF 1)		4REF
20.	72053507	ZERK - .25-28 (PART OF 1 & 2)		4REF
21.	7BF81225	BUSHING - STL 2.50 PIN X 1.25 LG (PART OF 1 & 2)		7REF
22.	60125699	PIN - LOCK TUBE 0.19 OD X 0.065 WALL		1

REV E 20131209

# Mast Assembly (40725983)

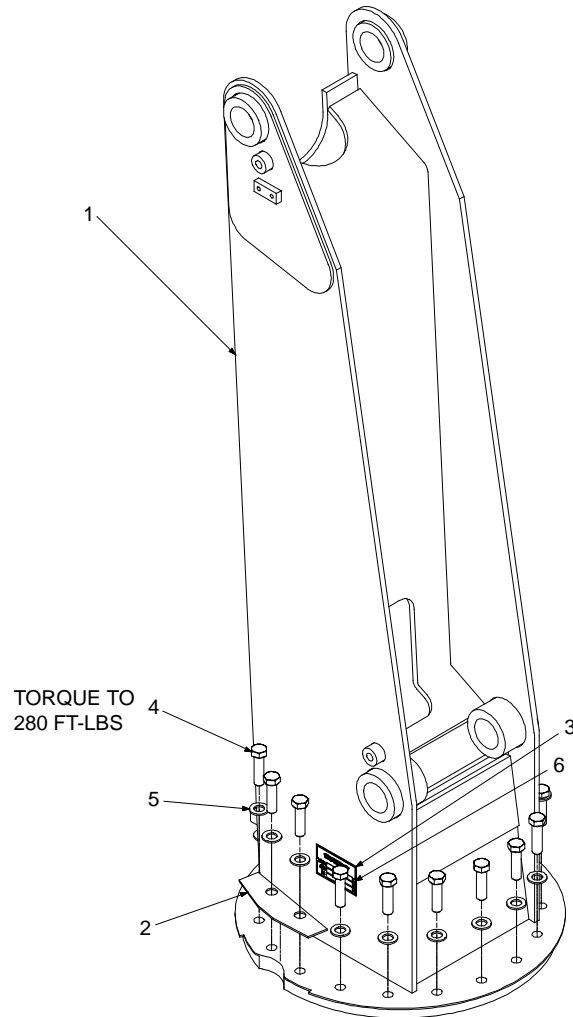

## 40725983 PARTS LIST

ITEM	PART #	DESCRIPTION	KIT	QTY
1.	52725866	WLDMT-MAST 12916		1
2.	60104247	COVER-PINION GEAR		1
3.	70029119	PLACARD-SERIAL NUMBER		1
4.	72060209	CAP SCREW .75-10X2.75 HH GR8 Z	7	18
5.	72063116	WASHER .75 N FLAT H ASTM F436Z	7	18
6.	72661638	TACK-METAL		2
7.	91725991	KIT-HRDW 12916 MAST		1

NEW 20140421

## Inner Boom Assembly (40725984)

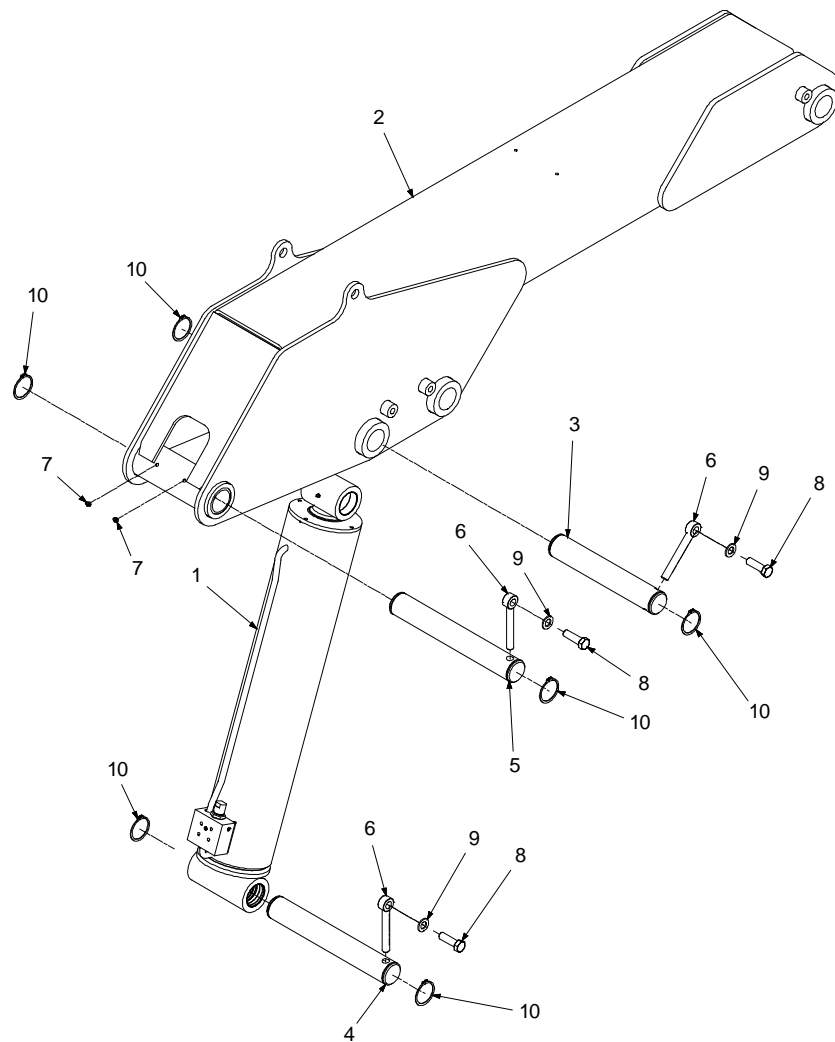

### 40725984 PARTS LIST

ITEM	PART #	DESCRIPTION	KIT	QTY
1.	3C194614	CYL-7.0/3.5 30.25S 44.00CC C		1
2.	52725867	WLDMT-INNER BOOM 12916		1
3.	60142110	PIN-TYPE PP 2.50X 15.00 (13.28)		1
4.	60142111	PIN-TYPE PP 2.50X 17.25 (15.53)		1
5.	60142112	PIN-TYPE PP 2.50X 17.50 (15.78)		1
6.	71415017	KEEPER-PIN .75		3
7.	72053508	ZERK-NPT .12	11	2
8.	72060186	CAP SCREW .75-10X 2.50 HH GR5 Z	11	3
9.	72063116	WASHER .75 N FLAT H ASTM F436Z	11	3
10.	72066103	RETAINING RING-EXT 2.50 STD		6
11.	91725990	KIT-HRDW 12916 BOOMS		1

NEW 20140421

# Inner Cylinder (3C194614)

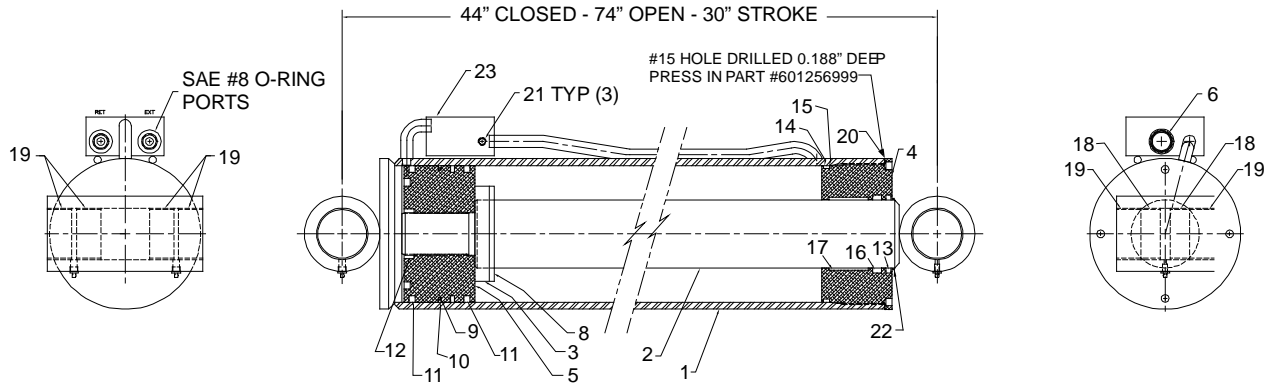

## NOTE:

- 1 IT IS RECOMMENDED THAT ALL COMPONENTS OF THE SEAL KIT BE REPLACED WHENEVER THE CYLINDER IS DISASSEMBLED. THIS WILL REDUCE FUTURE DOWNTIME.
- 2 APPLY "LUBRIPLATE #630.2" MEDIUM HEAVY, MULTI-PURPOSE LUBRICANT OR EQUIVALENT TO ALL PISTON AND HEAD GLANDS, LOCK RING AND ROD THREADS BEFORE ASSEMBLY.
- 3 APPLY "NEVER-SEEZ" OR EQUIVALENT BETWEEN THE HEAD AND THE CASE WHEN ASSEMBLING THE CYLINDER. KEEP AWAY FROM ALL SEALS.

3C194614 PARTS LIST				
ITEM	PART #	DESCRIPTION	KIT	QTY
1.	4C194611	CASE ASM – 7.014 BORE X 39.38 LG (INCL: 19 & 21)		1
2.	4G194610	ROD ASM – 3.50 X 40.94 X 2.19S (INCL: 18 & 19)		1
3.	6C075035	STOP TUBE – 3.50 ROD X .75 LG		1
4.	6HX70035	HEAD – 7.04 BORE X 3.50 ROD		1
5.	6I070218	PISTON – 7.04 BORE X 2.19 STGR		1
6.	73054242	VALVE – CBAL 25 GPM (5:1)		1
7.	9C282835	SEAL KIT – IMT 7.00B 3.50R 2.19S (INCL: 8-17, 20)		1
8.	60138278	STOP TUBE – 3.50 ROD X 0.25 LONG	7	1REF
9.	7Q072259	O-RING 6.25 X 6.50 X .12	7	1REF
10.	7T66P070	PISTON SEAL-DYNAMIC 7.00"	7	1REF
11.	7T651070	PISTON RING – 7.00 HYD CYL	7	2REF
12.	7T61N218	LOCK RING – NYLON 2.19"	7	1REF
13.	7R14P035	ROD WIPER – TYPE D 3.50 ROD	7	1REF
14.	7Q072363	O-RING – 6.50 X 6.88 X .19	7	1REF
15.	7Q10P363	BACKUP RING – 6.50 ID X 6.88 OD	7	1REF
16.	7R546035	U-CUP LOADED 3.50 X 4.00 X .38 "B"	7	1REF
17.	7T2N2X37	WEAR RING – ROD 3.50 ID X 2.00 W	7	1REF
18.	7BF81025	BUSHING 2.50 PIN 2.00 LONG (PART OF 2)		2REF
19.	7BF81225	BUSHING 2.50 PIN 1.25 LONG (PART OF 1 & 2)		6REF
20.	60125699	PIN – LOCK TUBE 0.19 OD X 0.065 WALL	7	1REF
21.	7PNPXT02	PLUG – PIPE SOC HD TAPED .12 (PART OF 1)		3REF
22.	A31-7-153	PAINT MASK		1
23.	5V152611	VALVE BLK-SGL GPM .75 16SAE (PART OF 1)		1

REV B 20120319

## Outer Boom Assembly (40725985)

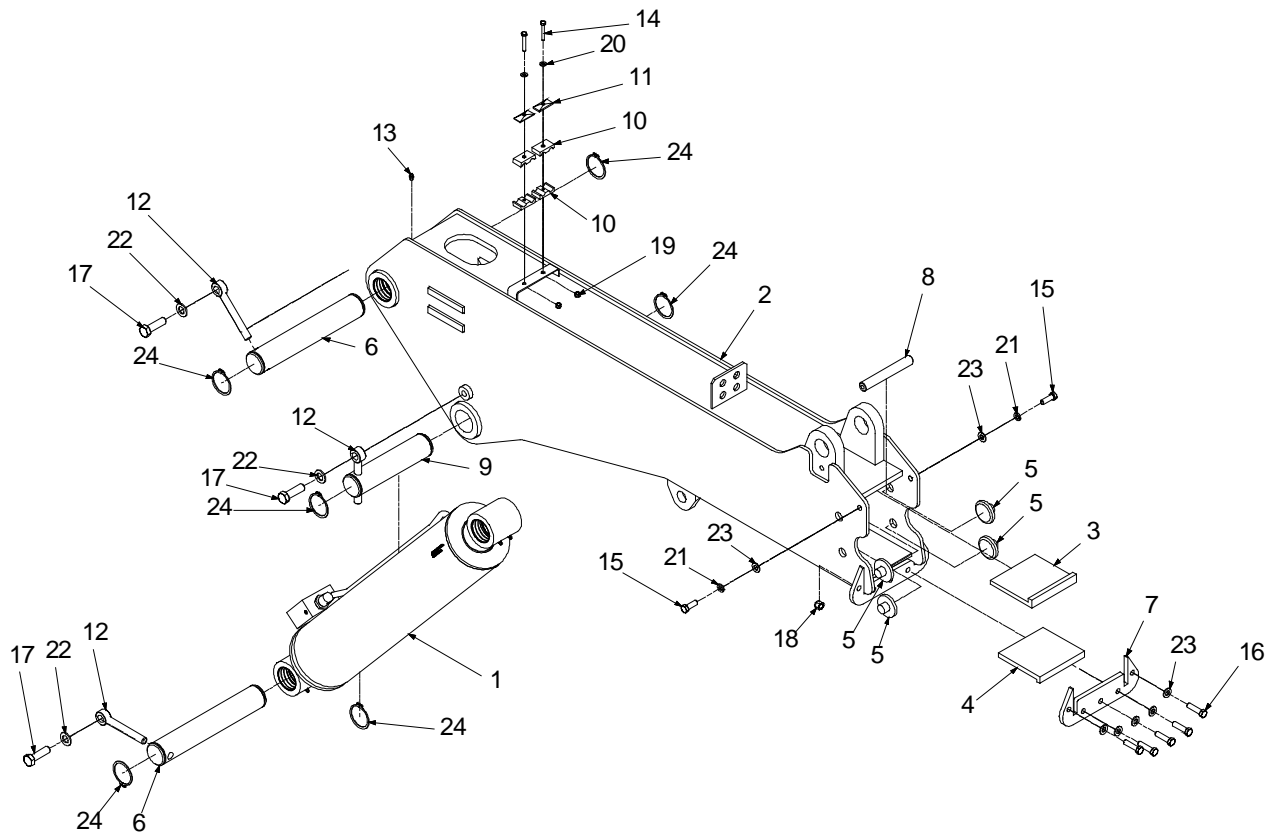

### NOTE:

- 1 ANYTIME THE PIN RETAINER PLATE BOLTS HAVE BEEN REMOVED, APPLY LOCTITE 262 TO THE THREADS BEFORE REASSEMBLY.

40725985 PARTS LIST				
ITEM	PART #	DESCRIPTION	KIT	QTY
1.	3C195613	CYL-6.5/3.5 26.25S 40.75CC C		1
2.	52725945	WLDMT-OUTER BOOM 12916		1
3.	60030501	WEAR PAD-RC 0.50 X 6.00 X 6.50		1
4.	60030502	WEAR PAD-RC 0.50 X 6.00 X 6.50		1
5.	60122985	WEAR PAD-RND 0.44 X 2.50 X 1.00 X .75		4
6.	60142110	PIN-TYPE PP 2.50 X 15.00 (13.28)		2
7.	60142317	CAP-WEAR PAD 12916		1
8.	60142318	PIN-TYPE H 1.00 X 6.94		1
9.	90142340	PIN-TYPE PP 2.50 X 10.75 (9.03)		1
10.	70034402	CLAMP-TWIN TUBE .62 OD		2
11.	70143829	COVER PLT-PAR29 CPT2		2
12.	71415017	KEEPER-PIN .75		3
13.	72053508	ZERK-NPT .12	25	1
14.	72060029	CAP SCREW .31-18 X 2.00 HH GR5 Z	25	2



40725985 PARTS LIST				
ITEM	PART #	DESCRIPTION	KIT	QTY
15.	72060093	CAP SCREW .50-13 X 1.50 HH GR5 Z	25	2
16.	72060095	CAP SCREW .50-13 X 2.00 HH GR5 Z	25	5
17.	72060186	CAP SCREW .75-10 X 2.50 HH GR5 Z	25	3
18.	72062080	NUT .50-13 HEX NYLOCK	25	5
19.	72062109	NUT .31-18 HEX NYLOCK	25	2
20.	72063002	WASHER .31 FLAT	25	2
21.	72063053	WASHER .50 LOCK	25	2
22.	72063116	WASHER .75 N FLAT H ASTM F436Z	25	3
23.	72063132	WASHER .50 FLAT ASTM F436	25	7
24.	72066103	RETAINING RING-EXT 2.50 STD		6
25.	91725990	KIT-HRDW 12916 BOOMS		1
NEW 20140421				

# Outer Cylinder (3C195613)

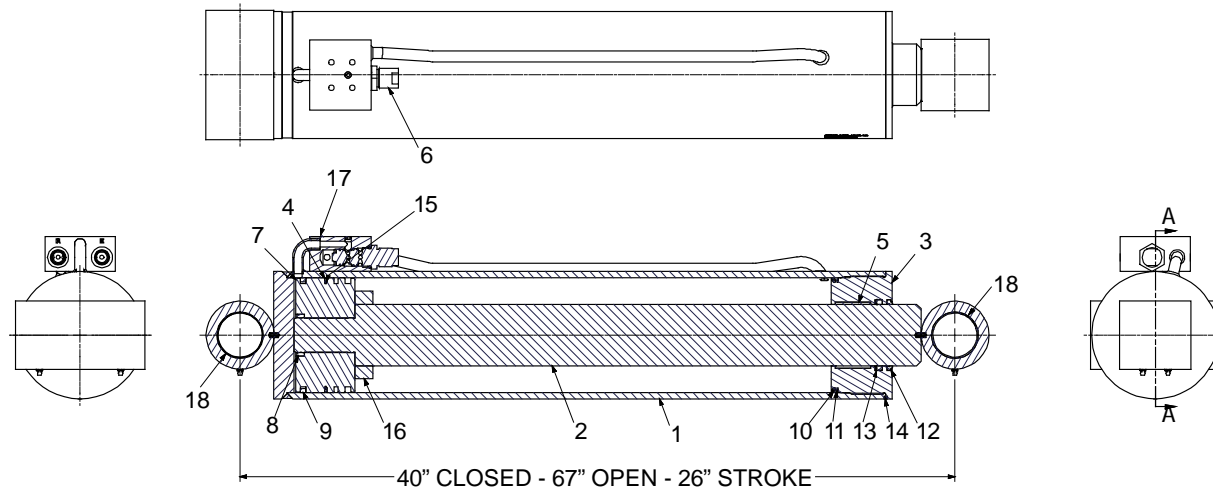

**NOTE:**

- 1 IT IS RECOMMENDED THAT ALL COMPONENTS OF THE SEAL KIT BE REPLACED WHENEVER THE CYLINDER IS DISASSEMBLED. THIS WILL REDUCE FUTURE DOWNTIME.
- 2 APPLY "LUBRIPLATE #630.2" MEDIUM HEAVY, MULTI-PURPOSE LUBRICANT OR EQUIVALENT TO ALL PISTON AND HEAD GLANDS, LOCK RING AND ROD THREADS BEFORE ASSEMBLY.
- 3 APPLY "NEVER-SEEZ" OR EQUIVALENT BETWEEN THE HEAD AND THE CASE WHEN ASSEMBLING THE CYLINDER. KEEP AWAY FROM ALL SEALS.

3C195613 PARTS LIST				
ITEM	PART #	DESCRIPTION	KIT	QTY
1.	4C195611	CASE ASM-6.50 BORE X 36.81 LG		1
2.	4G195611	ROD ASM-3.50 DIA X 37.69 LG 2.00 S 2.50		1
3.	6H065035	HEAD-6.50 BORE X 3.50 ROD		1
4.	7T66P065	PISTON SEAL-DYNAMIC 6.00in	19	1
5.	7T2N2X37	WEAR RING-ROD 3.50 ID X 2.00W	19	1
6.	73054242	VALVE-CBAL 25GPM (5:1)		1
7.	6I065200	PISTON-6.50 BORE X 2.00 STGR		1
8.	7T61N200	LOCK RING-NYLON 2.00in	19	1
9.	7T65I065	PISTON RING 6.00 HYD CYL	19	1
10.	7Q072361	ORING 6.00 X 6.38 X .19 70	19	1
11.	7Q10P361	BACKUP RING-6.00 ID X 6.38 OD	19	1
12.	7R14P035	ROD WIPER-TYPE D 3.50 ROD	19	1
13.	7R546035	U-CUP LOADED 3.50X4.00X.38B	19	1
14.	60125699	PIN-LOCK TUBE 0.19 OD X 0.065 WALL		1
15.	7Q072257	ORING 5.88 X 6.12 X .12 70	19	1
16.	6C100035	STOP TUBE - 3.50 ROD X 1.00 LONG	19	1
17.	5V152611	VALVE BLK-SGL 25 GPM .75 16SAE (PART OF 1)		1
18.	7BF81225	BUSHING 2.50 PIN 1.25 LONG (PART OF 1 & 2)		7
19.	9C262832	SEAL KIT-IMT 6.50B 3.50R 2.00S		1REF

REV D 20131007

# Extension Boom Assembly (40725986)

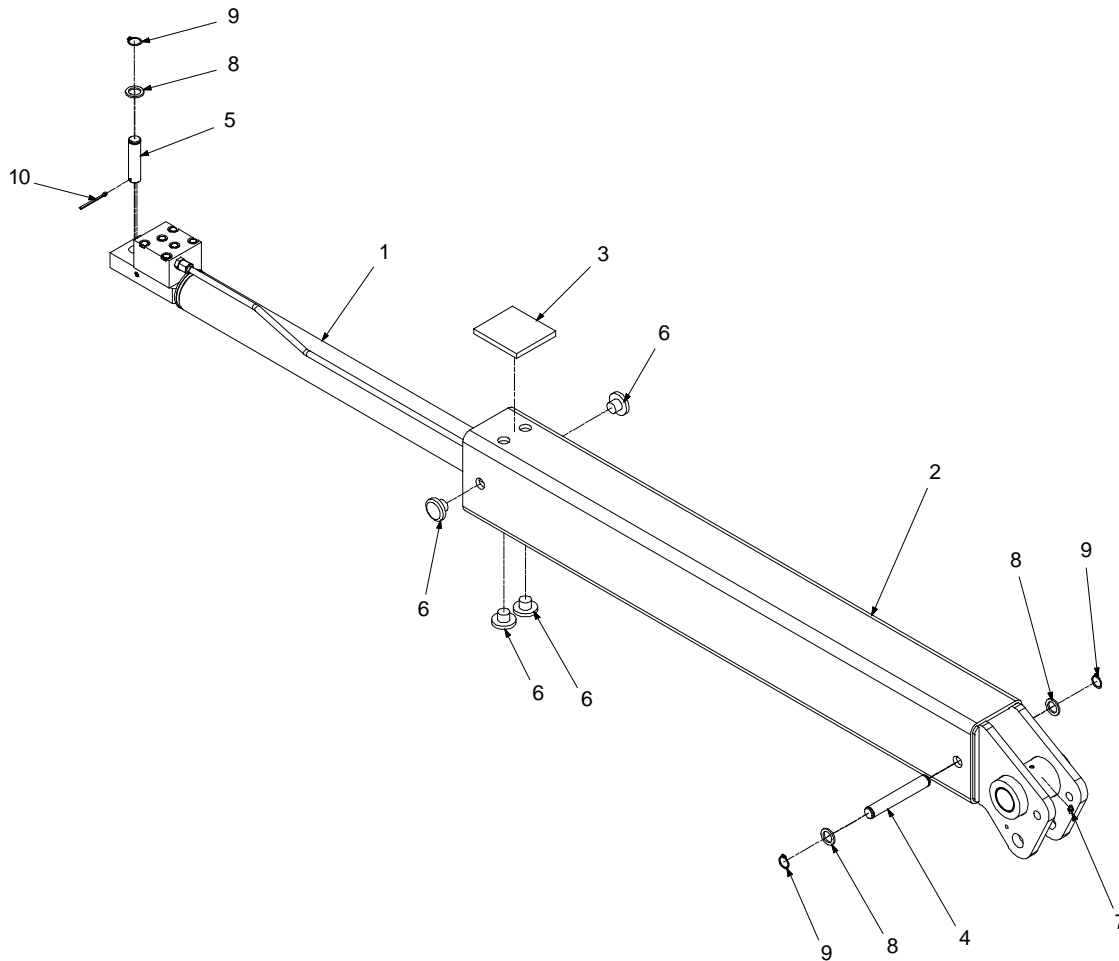

## 40725986 PARTS LIST

ITEM	PART #	DESCRIPTION	KIT	QTY
1.	51718065	CYL-3.0/2.0 40.00S 58.75CC C		1
2.	52725876	BOOM EXT WLDMT 12916		1
3.	60030499	WEAR PAD-RC 0.50X4.50X5.00		1
4.	60101874	PIN-TYPE A 1.00X6.75 (6.31)		1
5.	60101905	PIN-TYPE B 1.00X4.12 (3.62)		1
6.	60123777	WEAR PAD-RND 0.44X2.00X1.00X.75		4
7.	72053508	ZERK-NPT .12	11	1
8.	72063034	MACHY BUSHING 1.00X10 GA NR	11	3
9.	72066125	RETAINING RING-EXT 1.00 HD	11	3
10.	72066197	COTTER PIN .19X2.50	11	1
11.	91725990	KIT-HRDW 12916 BOOMS		1

NEW 20140421

# Extension Cylinder (51718065)

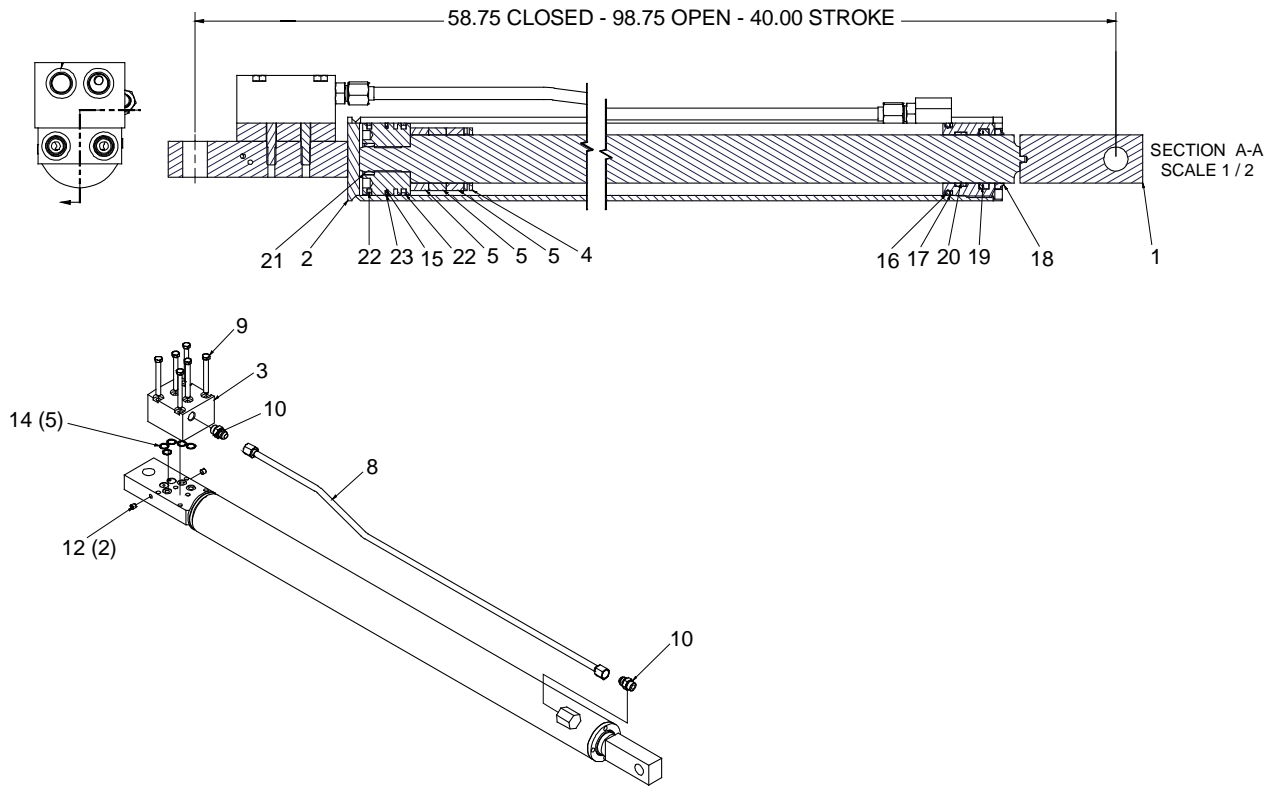

**NOTE:**

- 1 ITEM #14 IS PLACED BETWEEN #2 AND #3.
- 2 USE SERVICEABLE LOCTITE ON ITEM #9.
- 3 IT IS RECOMMENDED THAT ALL COMPONENTS OF THE SEAL KIT BE REPLACED WHENEVER THE CYLINDER IS DISASSEMBLED. THIS WILL REDUCE FUTURE DOWNTIME.
- 4 APPLY "LUBRIPLATE #630.2" MEDIUM HEAVY, MULTI-PURPOSE LUBRICANT OR EQUIVALENT TO ALL PISTON AND HEAD GLANDS, LOCK RING AND ROD THREADS BEFORE ASSEMBLY.
- 5 APPLY "NEVER-SEEZ" OR EQUIVALENT BETWEEN THE HEAD AND THE CASE WHEN ASSEMBLING THE CYLINDER. KEEP AWAY FROM ALL SEALS.

51718065 PARTS LIST				
ITEM	PART #	DESCRIPTION	KIT	QTY
1.	4G116510	ROD ASM-2.00 DIA X 51.88 LG 1.06 S 1.00		1
2.	52718045	CASE ASSEMBLY 3.02 BORE X 53.63L		1
3.	60125126	HOLDING VALVE 2.75 X 3.75 X 4.13		1
4.	6A025020	WAFER LOCK IMT 2.00	24	1
5.	6C075020	STOP TUBE - 2.00 ROD X .75 LONG		3
8.	70149900	PORT TUBE - .50 OD X 42.44 LONG		1
9.	72060055	CAP SCREW .38-16X 3.50 HH GR5 Z		6
10.	72532358	ADAPTER-M STR/, JIC 8 8		2
11.	73540052	VALVE-CBAL 1.75:1 3300 PSI ADJ		2
12.	7PNPXT02	PLUG-PIPE SOC HD TAPED .12	24	2

51718065 PARTS LIST				
ITEM	PART #	DESCRIPTION	KIT	QTY
14.	7Q072016	O RING .62X .75X .06 70	24	5
15.	7Q072145	O RING 2.56 X 2.75 X .09 70	24	1
16.	7Q072334	O RING 2.62 X 3.00 X .19 70	24	1
17.	7Q10P334	BACKUP RING – 2.62 ID X 3.00 OD	24	1
18.	7R14P020	ROD WIPER-TYPE D 2.00 ROD	24	1
19.	7R546020	U-CUP LOADED 2.00 X 2.50 X .38 "B"	24	1
20.	7T2N4022	WEAR RING-ROD 2.00 ID X .50W	24	1
21.	7T61N106	LOCK RING NYLON 1.06"	24	1
22.	7T65I030	PISTON RING-3.00 HYD CYL	24	2
23.	7T66P030	PISTON SEAL-DYNAMIC 3.00in		1
24.	9C121617	SEAL KIT-IMT 3.00B 2.00R 1.06S		1
25.	6H030020	HEAD-3.00 BORE X 2.00 ROD		1
26.	6I030106	PISTON-3.00 BORE X 1.06 STGR		1

## Hydraulic Diagram, Radio Remote (99905792)

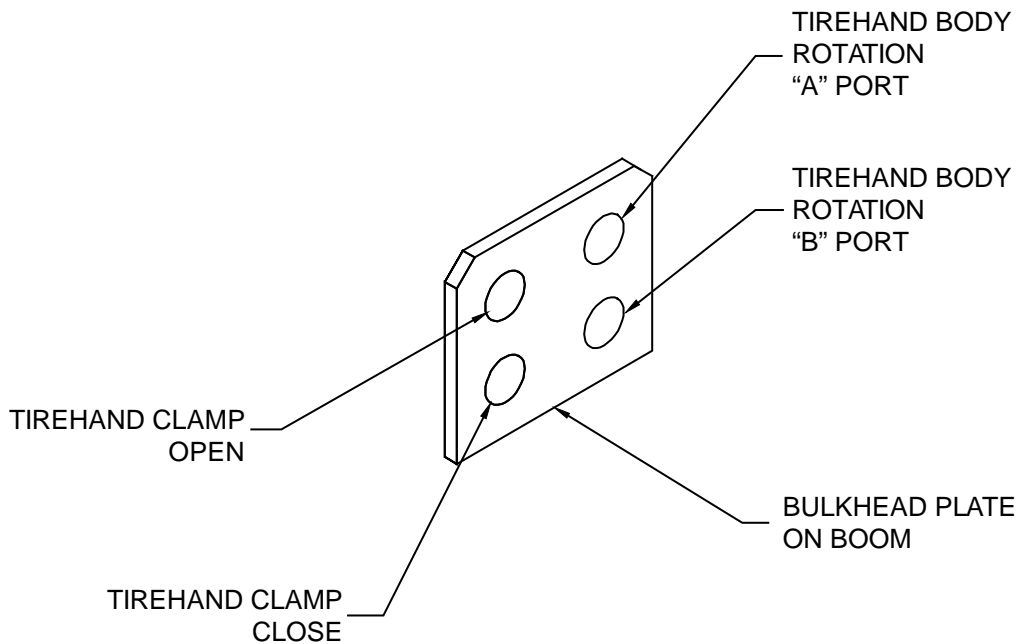

99905792 PARTS LIST			
ITEM	PART #	DESCRIPTION	QUANTITY
1.	51395200	HOSE-FJ .38 X 12.00 (8-8) 100R17	1
2.	51395201	HOSE-FF .38 X 15.00 (8-8) 100R17	1
3.	51395237	HOSE-FJ .25 X 10.50 (4-4) 100R17	1
4.	51395238	HOSE-FF .38 X 16.00 (8-8) 100R17	1
5.	51395239	HOSE-FF .38 X 83.00 (8-8) 100R17	2
6.	51395240	HOSE-FF .38 X 67.00 (8-8) 100R17	8
7.	51395241	HOSE-FF .38 X 195.00 (8-8) 100R17	4
8.	51395242	HOSE-FF .38 X 158.00 (8-8) 100R17	2
9.	51395303	HOSE-FF .25 X 70.00 (8-8) 100R17	2
10.	51395304	HOSE-FF .38 X 93.00 (8-8) 100R17	2
11.	51395645	HOSE-FJ .50 X 16.00 (8-8) 100R17	3
12.	51395887	HOSE-FJ .38 X 17.50 (6-6) 100R17	1
13.	51396284	HOSE-FZ .75 X 80.00 (12-12) 100R17	1
14.	51396460	HOSE-FF 1.00 X 42.00 (16-16) 100R17	1
15.	51397416	HOSE-FJ .38 X 100.00 (8-8) 100R17	2
16.	51399584	HOSE-FJ .75 X 44.00 (12-12) 100R17	1
17.	72053763	ELBOW-M STR/90/M JIC 8 8	11
18.	72053767	ELBOW-M STR/90 M JIC 12 12	3
19.	72532136	PLUG-STR HEX HD STL 13 (1.06 THD)	2
20.	72532351	ADPTR-M STR/M JIC 4 4	2
21.	72532358	ADPTR-M STR/M JIC 8 8	6
22.	72532359	ADPTR-M STR/M JIC 10 8	4

99905792 PARTS LIST			
ITEM	PART #	DESCRIPTION	QUANTITY
23.	72532366	ADPTR-M STR/M JIC 12 12	2
24.	72532369	ADPTR-M STR/M JIC 12 16	1
25.	72532657	TEE-SWVL NUT RUN JIC 8	2
26.	72532675	CAP-JIC STL 8 (.75 THD)	6
27.	72532980	SWIVEL-M JIC/F JIC 8 8 IN-LINE	2
28.	72533000	TEE-SWVL NUT RUN JIC 16	1
29.	72533028	ADPTR-M JIC/F JIC 12 16	1
30.	72533029	NUT-JIC STL 16 (1.31 THD)	1
31.	72533373	UNION-BULKHEAD JIC 8 (3/4-16)	6
32.	72533558	TEE-UNION JIC 16	1
33.	72533566	SWIVEL-M JIC/M JIC 8 8 IN-LINE	10
34.	72533597	TEE-STL JIC/STR/JIC 8 8 8 BRANCH	1
35.	72534371	UNION-F JIC/SWIVEL/F JIC 8 8	1
36.	VARIES	VALVE-SOL NO 2-WAY OVERLOAD FASTONS	2
37.	VARIES	VALVE ASM-RELIEF/SOL HYD SHUTD	1
38.	70733498	ACCUMULATOR-14K160TH	1
39.	72066507	CLAMP-EXHAUST U 2.25	1
40.	73051223	MOTOR-HYD C104-1021 NO DANFOSS	1
41.	71056623	BRAKE-HYD SWING DRIVE	1
42.	VARIES	VALVE BANK-8 SECT	1
43.	51715128	VB ASM-1SEC V20 W/PB CS OR 12916 RAD	1
44.	73054370	VALVE-CBAL SUN01 CBEA-LAN-YHK	1
45.	51399602	HOSE-FF 1.00 X 21.00 (16-16) 100R17	1
46.	51706534	HOSE-FF .75 X 22.00 (12-12) 100R16	1
NEW 20140410			

## Hydraulic Diagram, Radio Remote (99905792)

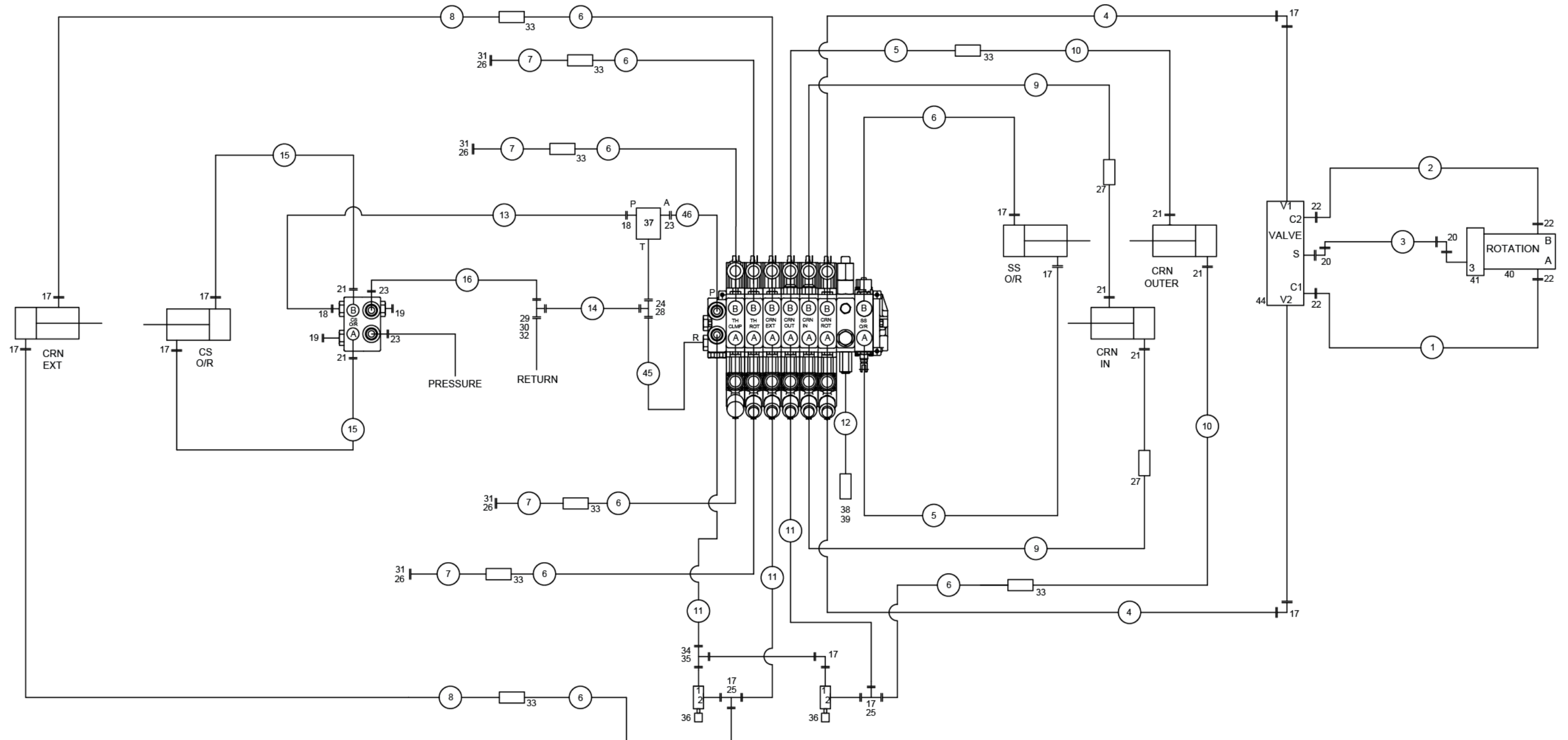



## Relief Valve Assembly, 12V Radio (73055278)

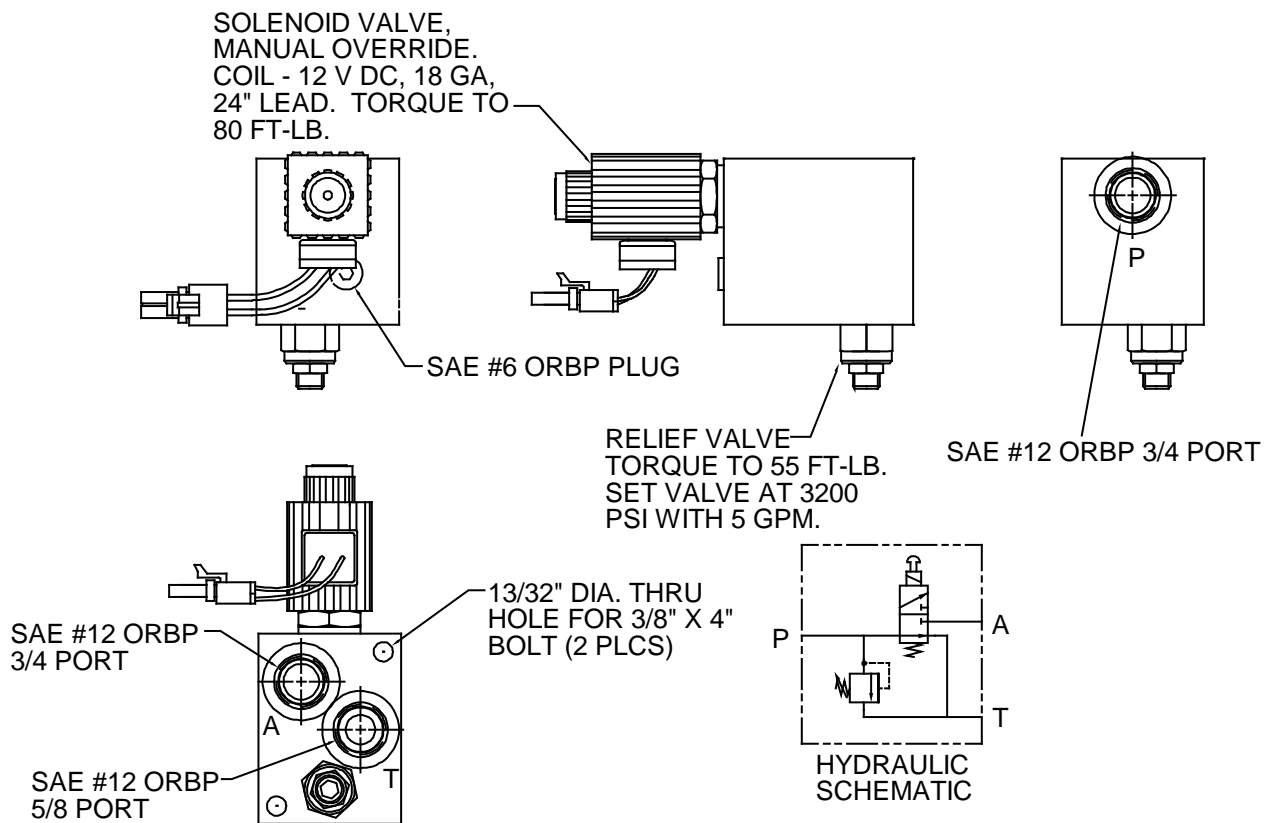

### REFERENCE PARTS FOR SERVICE:

Coil - 77040456

## Relief Valve Assembly, 24V Radio (73055298)

Reference drawing 73055278.

### REFERENCE PARTS FOR SERVICE:

Coil - 77040447

## Solenoid Dump Valves

### 12V Solenoid Dump Valves

12V Normally Open Solenoid Valve - 73054980  
Replacement Coil - 77041456

### 24V Solenoid Dump Valves

24V Normally Open Solenoid Valve - 73540142  
Replacement Coil - 77040463

# Control Kit – Manual 8 Function (90704441)

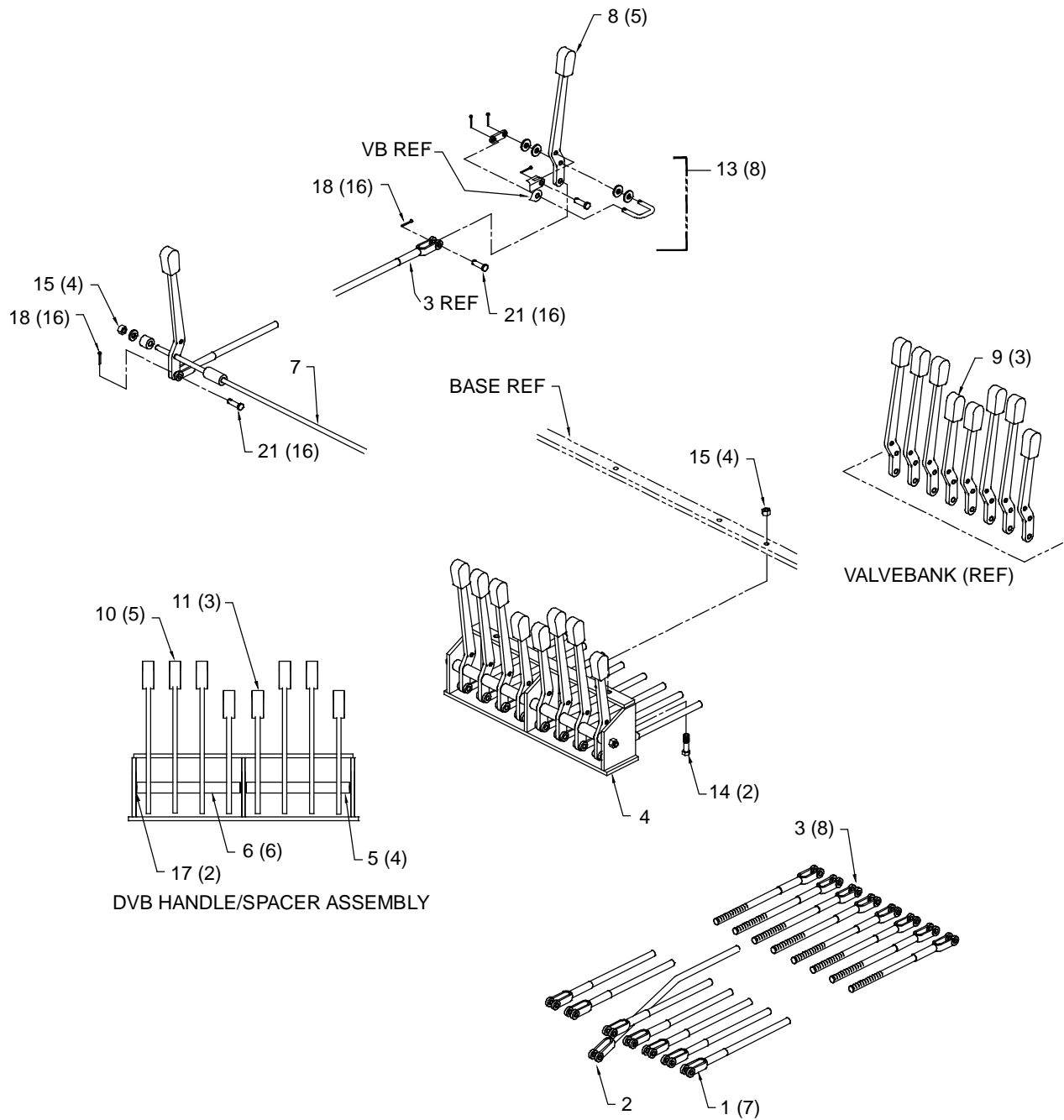

**NOTE:**

1 ITEMS 22 AND 23 REMOVED FROM VIEW FOR CLARITY.

<b>90704441 PARTS LIST</b>			
ITEM	PART #	DESCRIPTION	QUANTITY
1.	52702016	CONTROL ROD - FEMALE	7
2.	52702017	CONTROL ROD - BENT FEMALE	1
3.	52702018	CONTROL ROD - MALE	8
4.	52702777	DUMMY VALVEBANK	1
5.	60030045	SPACER .63	4
6.	60030046	SPACER 1.50	6
7.	60105503	ROD, DUMMY VB	1
8.	70141982	CONTROL HANDLE - LONG (VB)	5
9.	70141983	CONTROL HANDLE - SHORT (VB)	3
10.	70141984	CONTROL HANDLE - LONG (DBV)	5
11.	70141985	CONTROL HANDLE - SHORT (DVB)	3
13.	94731839	LINK & PIN KIT	8
14.	72060026	CAP SCR .31-18X 1.25 HH GR5 Z	2
15.	72062109	NUT .31-18 HEX NYLOC	4
17.	72063002	WASHER WRT .31	2
18.	72066168	PIN, COTTER .09 X .75 PLAIN	16
21.	72066338	PIN, CLEVIS .31 X 1.00 PLAIN	16
22.	52713782	HANDLE-HYD SHUTDOWN UNIVERSAL	4
23.	60120092	TUBE-RD .75IDX 1.00DX 15.50	2
REV E 20130415			

# Valvebank Assembly – 8 Section (51706642)

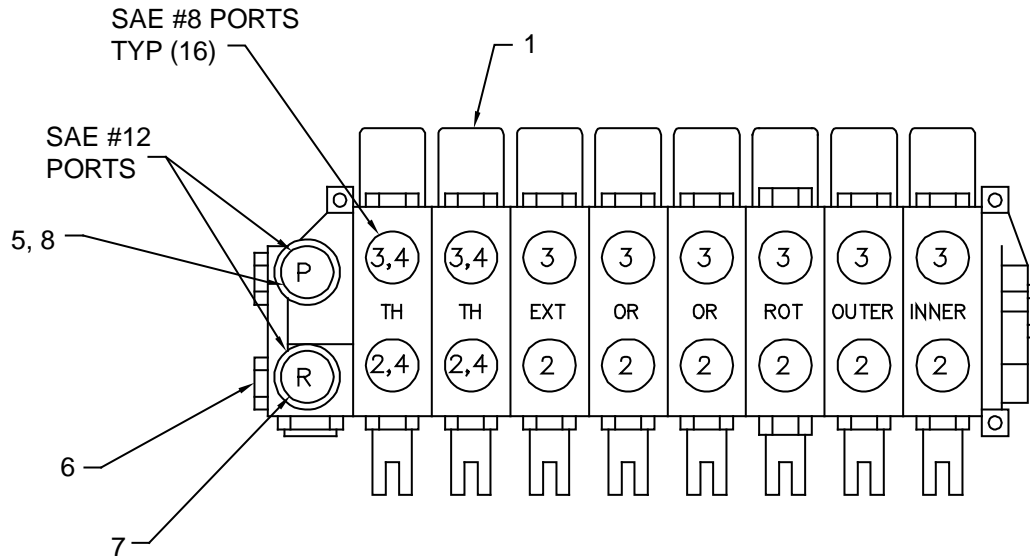

51706642 PARTS LIST			
ITEM	PART #	DESCRIPTION	QUANTITY
1.	51706643	VB-8SEC V20 1216	1
2.	72532666	ELBOW-M STR/M JIC XLG #8 #8	8
3.	72053763	ELBOW-M STR/90/M JIC #8 #8	8
4.	72532675	CAP-JIC STL .75 THD	4
5.	60107995	ELBOW-PRESSURE GAUGE MODIFIED	1
6.	72053767	ELBOW-M STR/90/M JIC #12 #12	1
7.	72532369	ADPTR-M STR/M JIC 12 16	1
8.	73054435	GAUGE-PRESS LIQ FILLED 5000PSI	1
REV F 20021122			

# Valvebank Assembly – 8 Section (51706643)

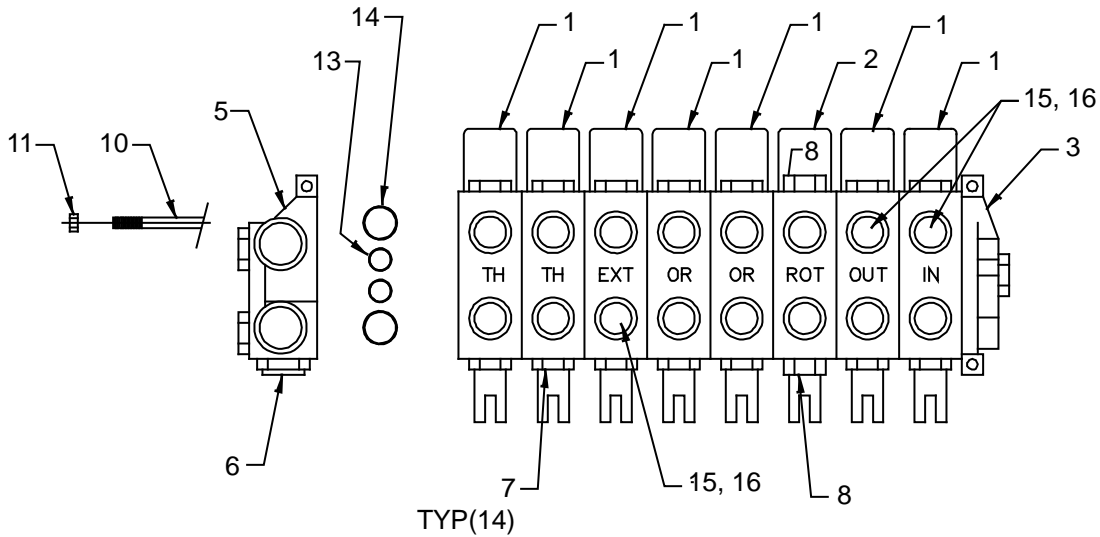

51706643 PARTS LIST			
ITEM	PART #	DESCRIPTION	QUANTITY
1.	73054432	VALVE SECTION V20 4 WAY SAE #8	7
2.	73054452	VALVE SECTION V20 4 WAY W/BX SAE #8	1
3.	73731241	END COVER – RH V20 VALVE W/CONVERSION PLUG	1
5.	73731424	END COVER – LH V20 VALVE (2300 PSI)	1
6.	73054673	RELIEF VALVE – 2300 PSI (RP51A) (PART OF 5)	1REF
7.	73054010	LOAD CHECK PLUG ASM – V20	14
8.	73054007	RELIEF – RC NON ADJ (1800 PSI)	2
10.	73014596	STUD – VALVE BANK .38 X 15.25 LG	3
11.	72062037	NUT - .38-24 HEX	6
12.	51393494	O-RING KIT (SERVICE PART)	REF
13.	7Q072117	O-RING .81 X 1.00 X .09	18
14.	7Q072119	O-RING .94 X 1.12 X .09	18
15.	70142402	ORIFICE PLATE (10817-125)	3
16.	70142403	SPRING – ORIFICE (10821-001)	3
REV B 19950418			

# Hydraulic Kit – 6 Section (91703946)

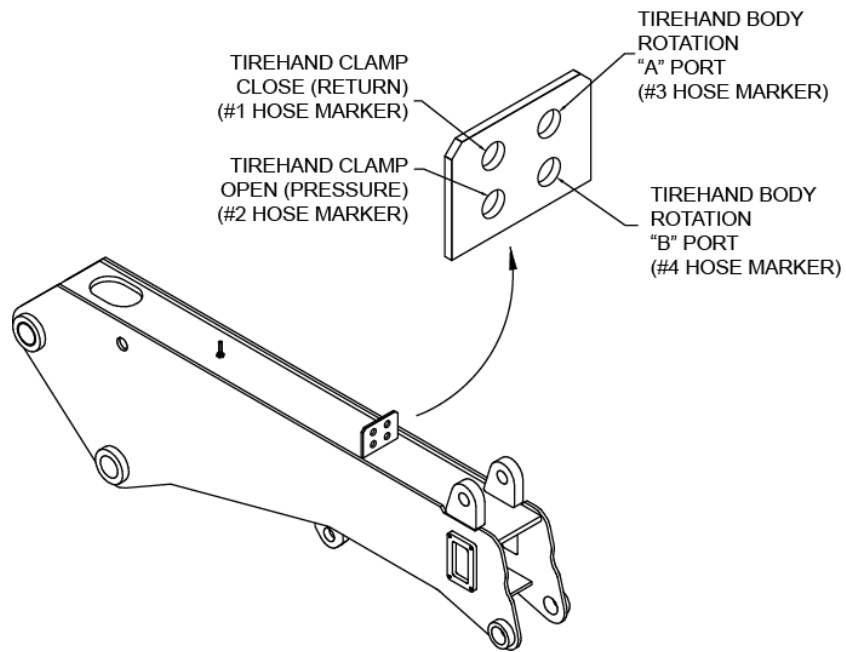
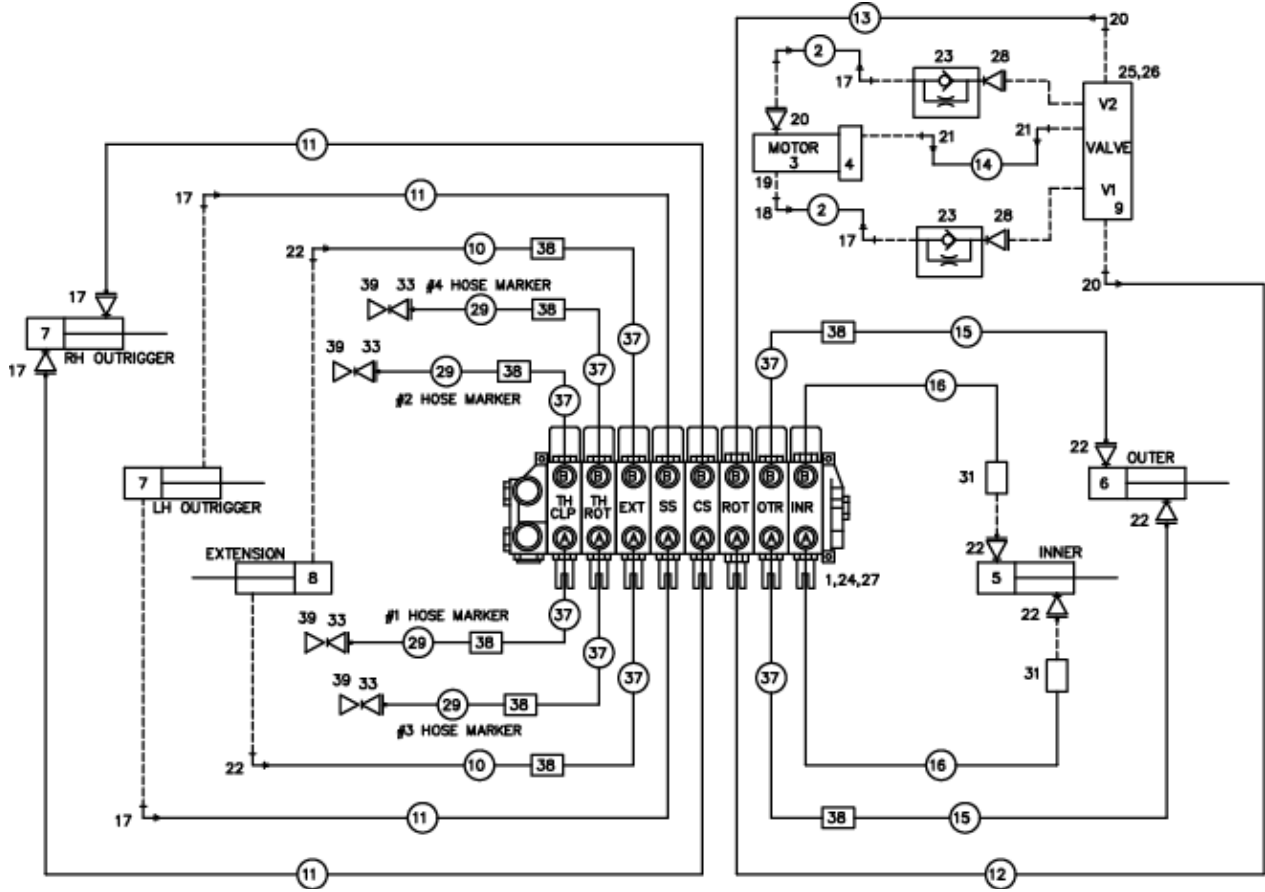

**NOTE:**

1 FOR HYDRAULIC OVERLOAD, SEE ASSEMBLY 51717130.

<b>91703946 PARTS LIST</b>				
ITEM	PART #	DESCRIPTION	KIT	QUANTITY
1.		VALVEBANK – 8 SEC		REF
2.	51395200	HOSE ASM-FF .38X 12.00 (8-8)	30	2REF
3.		MOTOR		REF
4.		BRAKE		REF
5.		CYLINDER-INNER		REF
6.		CYLINDER-OUTER		REF
7.		CYLINDER-OUTRIGGER		REF
8.		CYLINDER-EXTENSION		REF
9.	73054370	VALVE-CBAL SUN01 CBEA-LAN-YHK		1
10.	51395242	HOSE ASM-FF .38X 158.00 (8-8)	30	2REF
11.	51395239	HOSE ASM-FF .38X 83.00 (8-8)	30	4REF
12.	51395201	HOSE ASM-FF .38X 15.00 (8-8)	30	1REF
13.	51395238	HOSE ASM-FF .38X 16.00 (8-8)	30	1REF
14.	51395237	HOSE ASM-FF .25X 10.50 (4-4)	30	1REF
15.	51395304	HOSE ASM-FF .38X 93.00 (8-8)	30	2REF
16.	51395303	HOSE ASM-FF .38X 70.00 (8-8)	30	2REF
17.	72053763	ELBOW-M STR/90/M JIC #8 #8		6
18.	72532666	ELBOW-M STR/M JIC XLF #8 #8		1
19.	72531206	ADPTR-M STR/F STR #10 #8		1
20.	72053764	ELBOW-M STR/90/M JIC #10 #8		3
21.	72053758	ELBOW-M STR/90/M JIC #4 #4		2
22.	72532358	ADPTR-M STR/M JIC #8 #8		6
23.	73054921	VALVE-FLOW CONTROL PC		2
24.	72060033	CAP SCR .31-18X 3.00 HH GR5 Z		3
25.	72060051	CAP SCR .38-16X 2.25 HH GR5 Z		2
26.	72062103	NUT .38-16 HEX NYLOC ZINC		2
27.	72062109	NUT .31-18 HEX NYLOC ZINC		3
28.	72532728	UNION-M STR/M STR .75 .75		2
29.	51395241	HOSE ASM-FF .38X 195.00 (8-8)	30	4REF
30.	51713944	HOSE KIT-12916 CRANE		1
31.	72532980	ADPTR-PR SW IN-LINE JIC .75X16		4
33.	72533373	UNION-BULKHEAD 37 DEG JIC .75		4
37.	51395240	HOSE-FF .38 X 67.00 OAL (8-8)		8
38.	72533566	SWIVEL-MJIC/MJIC #8 INLINE		8
39.	72532675	CAP-JIC STL .75 THD		4
REV H 20111118				

## Hydraulic Overload Kit, 3-Function (51717130)

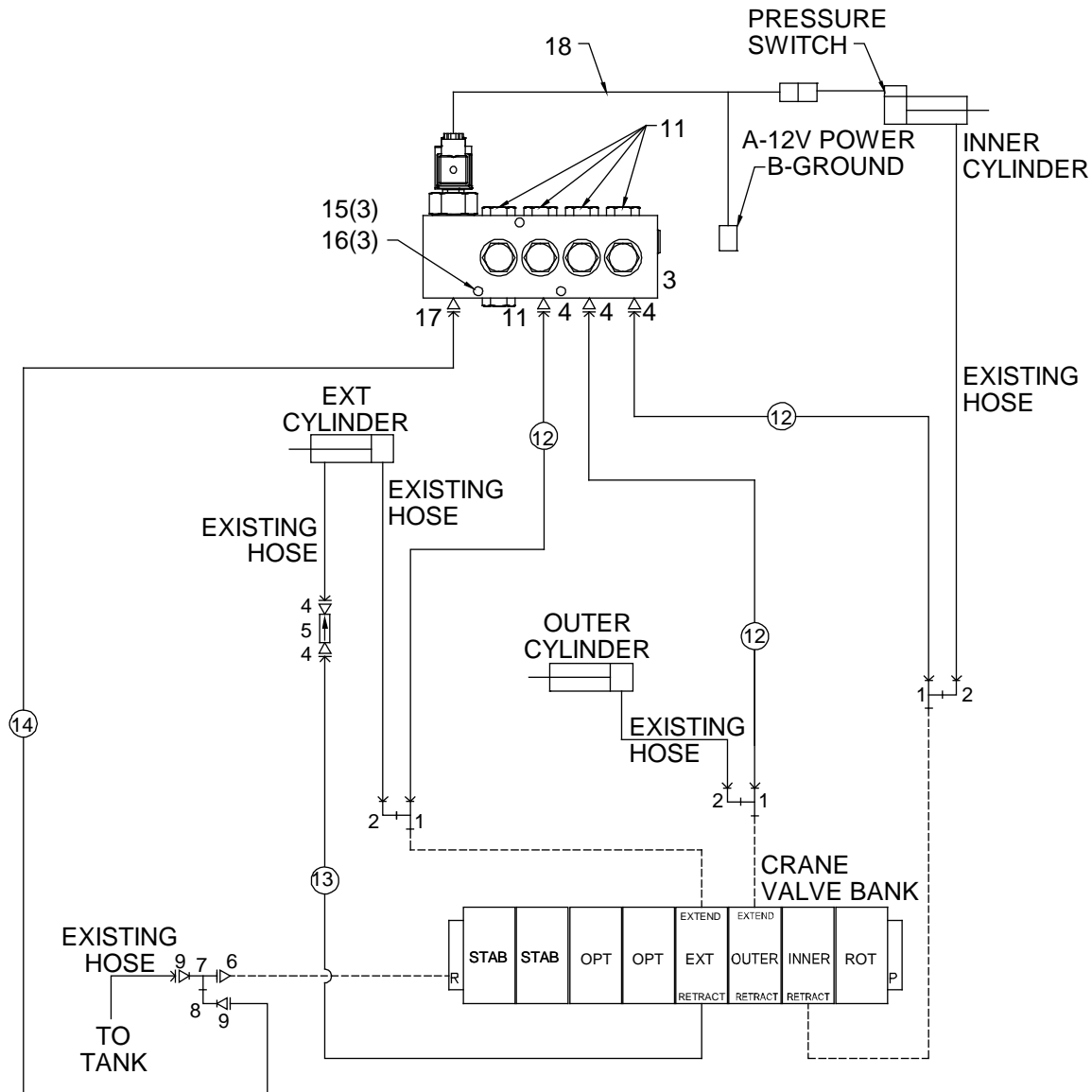

### NOTES:

- 1 THE OVERLOAD SYSTEM FUNCTIONS SUCH THAT WHEN THE INNER CYLINDERS ARE OVERLOADED, THE PRESSURE SWITCH WILL ACTIVATE THE SOLENOID DUMP VALVE(S), THUS DUMPING OIL TO "TANK" AND PREVENTING THE OUTER CYLINDER EXTEND, EXTENSION CYLINDER EXTEND, OR WINCH UP FUNCTIONS.
- 2 IN AN OVERLOAD CONDITION, INNER BOOM RETRACT, OUTER BOOM EXTEND, EXTENSION CYLINDER EXTEND, AND WINCH UP FUNCTIONS ARE SHUT DOWN.
- 3 INSTALL A RELIEF VALVE (73054426 - 700 PSI) IN THE EXTEND LINE OF THE EXTENSION CYLINDER SO THE CYLINDER WILL NOT EXTEND WHEN THE DUMP SYSTEM IS ACTIVATED.
- 4 USE HYDRAULIC OVERLOAD KIT IN CONJUNCTION WITH THE ELECTRIC CAPACITY ALERT KIT.



<b>51717130 PARTS LIST</b>			
ITEM	PART #	DESCRIPTION	QUANTITY
1.	72532657	TEE #8JIC SWVL NUT RUN	3
2.	72532658	ELBOW #8MJIC #8FJIC	3
3.	73540463	VALVE BLOCK ASM	1
	77441576	COIL FOR 73540463	1
4.	72532358	ADAPTER #8MSTR #8MJIC	5
5.	73054426	VALVE-ADJ RELIEF	1
6.	72053676	ADAPTER 3/4MPT #12MJIC	1
7.	72532950	TEE-SWIVEL NUT RUN JIC#12	1
8.	72532696	ELBOW-#12MJIC #12FJIC SW	1
9.	72532972	ADPTR-#8MJIC#12FJIC	2
11.	72532141	PLUG STR HEX HD STL 3/4 THD	4
12.	51703863	HOSE ASM-FF 3/8 X 14	3
13.	51706239	HOSE ASM-FF 1/2 X 5	1
14.	51704914	HOSE ASM-FF 3/8 X 60	1
15.	72060034	CAP SCR 5/16-18 X 3.25 HH	3
16.	72062109	NUT 5/16-18 HEX NYLOC ZINC	3
17.	72532360	ADPTR-#12MSTR #8MJIC	1
18.	77441025	HARNES-OVERLOAD	1
REV. B 20111221			

# Electrical Control Cabinet (41718269-12V, 41718425-24V)

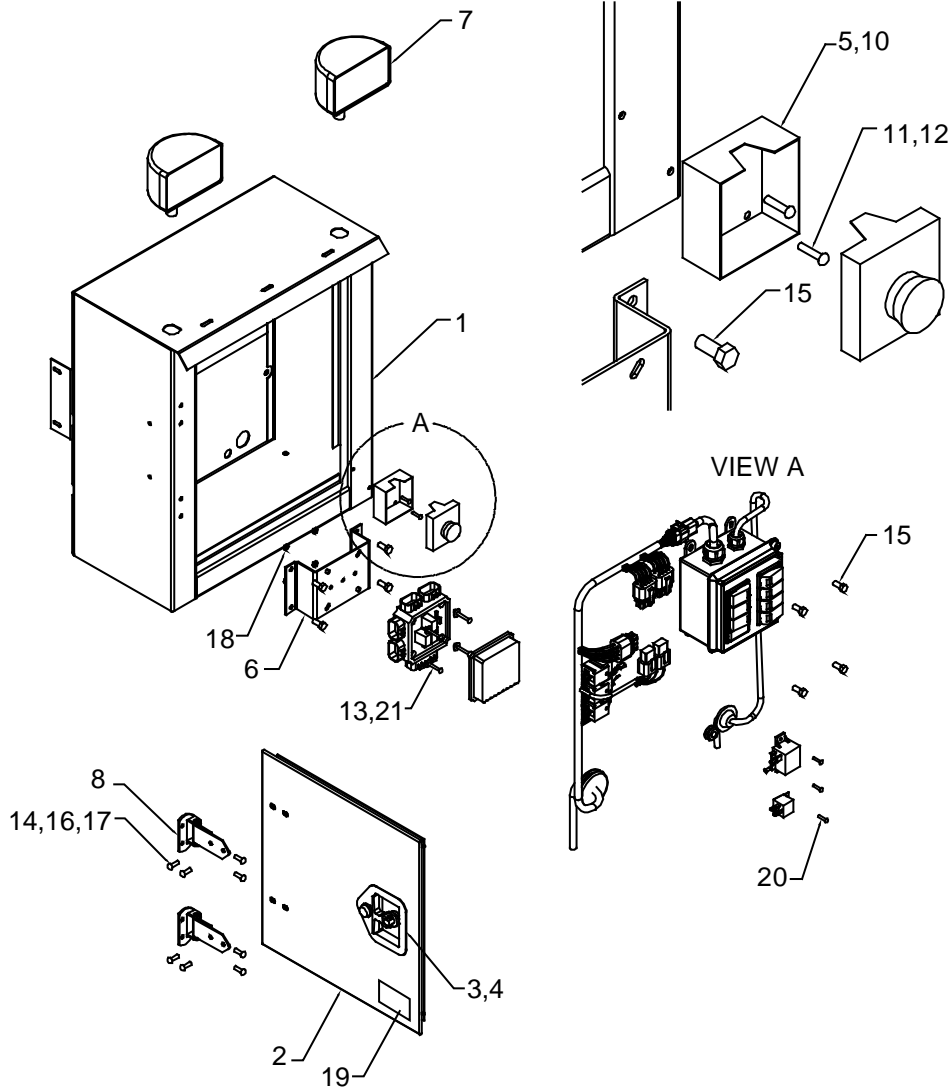

**NOTES:**

- 1 INSTALL WEATHERSTRIP (ITEM #9) AROUND DOOR OPENING.
- 2 INSTALL DUAL-LOCK FASTENER (ITEM #19) INSIDE LEFT SIDE WALL OF CABINET. USE ITEM #19 TO MOUNT RADIO REMOTE CONTROL CHARGER. (USE 2 STRIPS ON CABINET WALL AND 2 STRIPS ON CHARGER.

41718269/41718425 PARTS LIST				
ITEM	PART #	DESCRIPTION	DETAILS	QUANTITY
1.	41721887	CABINET WELDMENT (WAS 52715880)		1
2.	52713707	DOOR WELDMENT		1
3.	72661470	LATCH ASSEMBLY, 1-PT		1
4.	76393253	GASKET, LATCH WITH STUDS		1
5.	77041486	SWITCH, E-STOP		1

41718269/41718425 PARTS LIST				
ITEM	PART #	DESCRIPTION	DETAILS	QUANTITY
6.	60121574	BRACKET, FUSE/RELAY BOX		1
7.	77040424	LIGHT, WORK LAMP	12V	2
	77040572	LIGHT, WORK LAMP	24V	2
8.	72661383	HINGE	SS 10-GA	2
9.	89393637	WEATHERSTRIP	1/2X1/2 TRIMLOC	5.5'
10.	77044468	CONNECTOR	1/2" STR REL .12-.25	1
11.	72601725	SCREW-MACHINE	6-32 1/2 ROUND HEAD PHILLIPS	2
12.	72601726	NUT	6-32 HEX NYLOC	2
13.	72060643	SCREW-MACHINE	10-24 X 1.50 RDH SST	4
14.	72601652	SCREW-MACHINE	1/4-20X3/4 TRHTORXSS	8
15.	72061004	SCR-SHEET METAL	14X3/4 SLT HEXZ	8
16.	72062194	NUT	SS 1/4-20 NYLOC	6
17.	72062264	NUT	1/4-20 WELD TP2120	2
18.	72062053	NUT	10-24 HEX ZINC	4
19.	70396515	DECAL-WARNING-NO STORE IN E-CABINET		1
20.	72060835	SCREW-SELF TAPPING	8-18 3/4 HHZINC	5
21.	72063166	WASHER	SS 1/4 WRT 18-8 5/8 OD	4
REV. C 20080903				

# Electrical Control Box Assembly (41718269-12V, 41718425-24V)

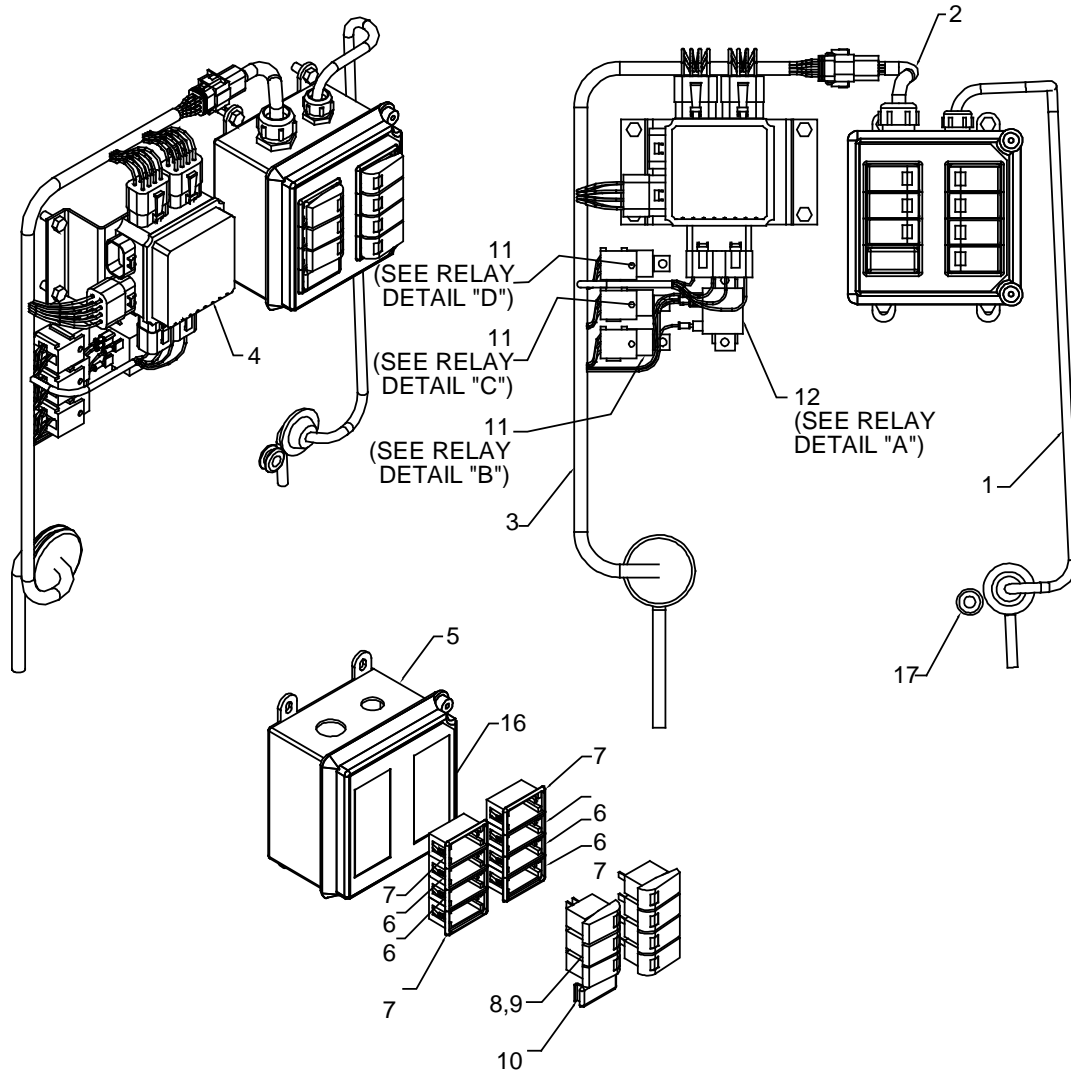

**NOTE:**

1 FOR COMPLETE WIRING CONNECTIONS, SEE WIRING SCHEMATIC.

**41718269/41718425 DRAWING**

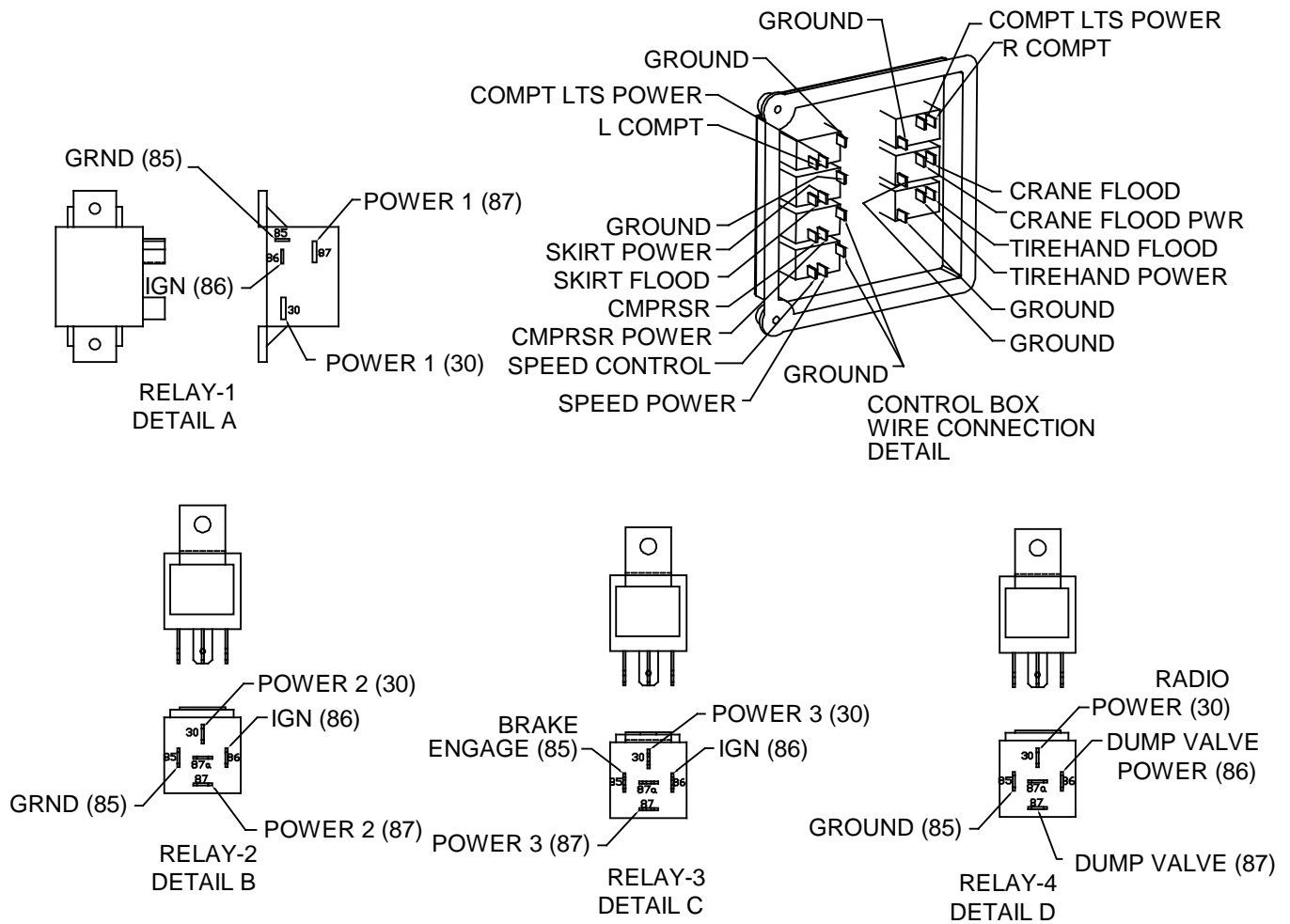

41718269/41718425 PARTS LIST				
ITEM	PART #	DESCRIPTION	DETAILS	QUANTITY
1.	77044919	HARNESS, SWITCH BOX OUT		1
2.	77441086	HARNESS, SWITCH BOX IN		1
3.	77441085	HARNESS, CRANE POWER		1
4.	77044935	FUSE/RELAY BOX		1
5.	77044797	SWITCH BOX		1
6.	77041504	SWITCH, ROCKER MTG PAN MID		4
7.	77041502	SWITCH, ROCKER MTG PAN END		4
8.	77041500	SWITCH, ROCKER BODY	12V	7
	77041672	SWITCH, ROCKER BODY	24V	7
9.	77041499	SWITCH, ROCKER RED ACT.		7
10.	77041571	SWITCH, ROCKER PLUG		1
11.	77041251	RELAY	40 AMP (12V)	3
	77041674	RELAY	20 AMP (24V)	
12.	77040391	RELAY	12V DC 75 AMP (12V)	1
	77040455	RELAY	24V DC 50 AMP (24V)	1
13.	77044573	CONNECTOR	PACKARD MALE 2-WAY WEATHERPACK	1

41718269/41718425 PARTS LIST				
ITEM	PART #	DESCRIPTION	DETAILS	QUANTITY
14.	77044552	TERMINAL	MALE 18-20 GA WEATHERPACK	2
15.	70394069	SEAL, CABLE CONNECTOR		2
16.	70395669	DECAL, OTR LIGHT SWITCH		1
17.	76391200	RUBBER GROMMET	9/16	1
18.	77041599	RELAY	12V DC	3REF
	77041677	RELAY	24V DC	3REF

## Relay Fuse Box, 12V & 24V (77044935)

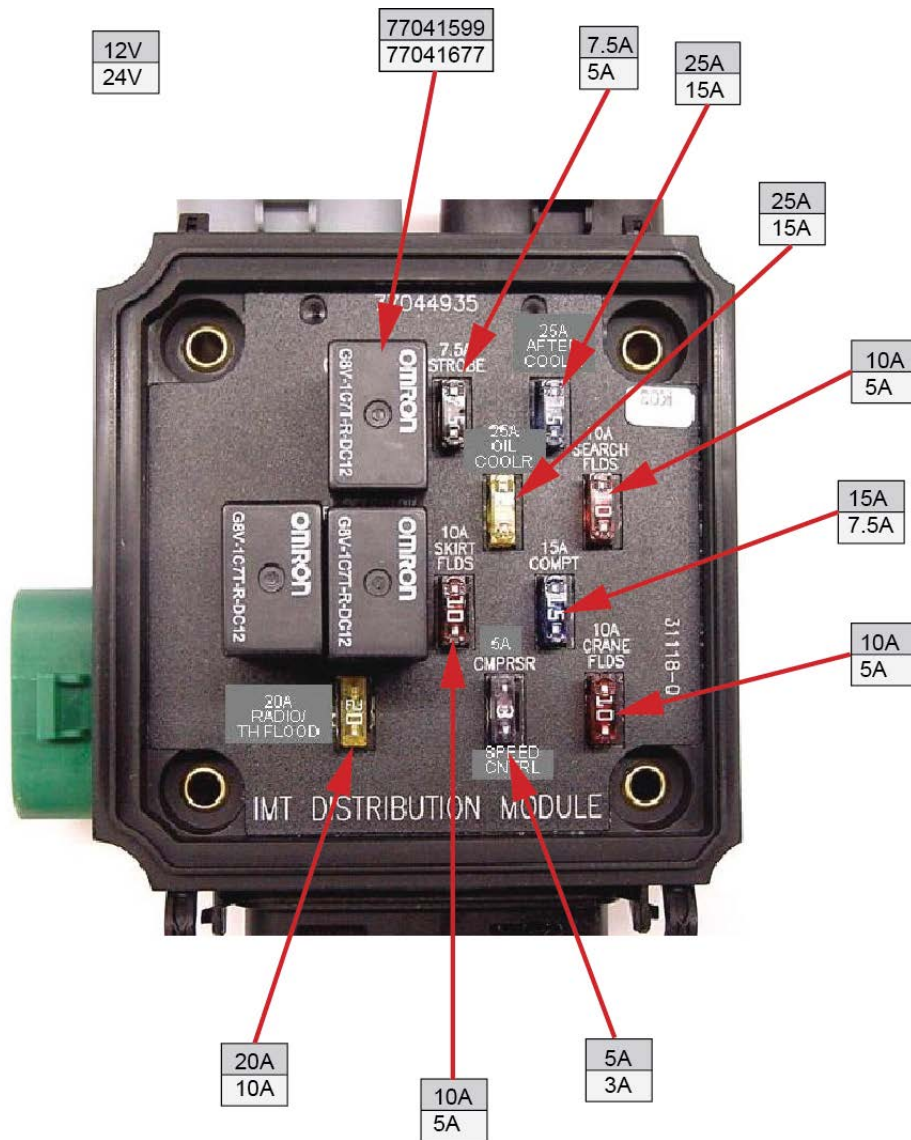

ITEM	PART #
3A	77044925
5A	77044946
7.5A	77044924
10A	77044947
15A	77044948
20A	77044923
25A	77041663

---

# Radio Remote

Radio Remote Kit 458 Frequency – 73733481

Radio Remote Kit 434 Frequency – 73733890

## REFERENCE PARTS FOR SERVICE:

### **Transmitter - 70146274**

458 Frequency - 57149

434 Frequency - 70734224

### **Receiver - 70146275**

458 Frequency - 57129

434 Frequency - 70734225

# Installation Kit-Manual Controls (93708876)

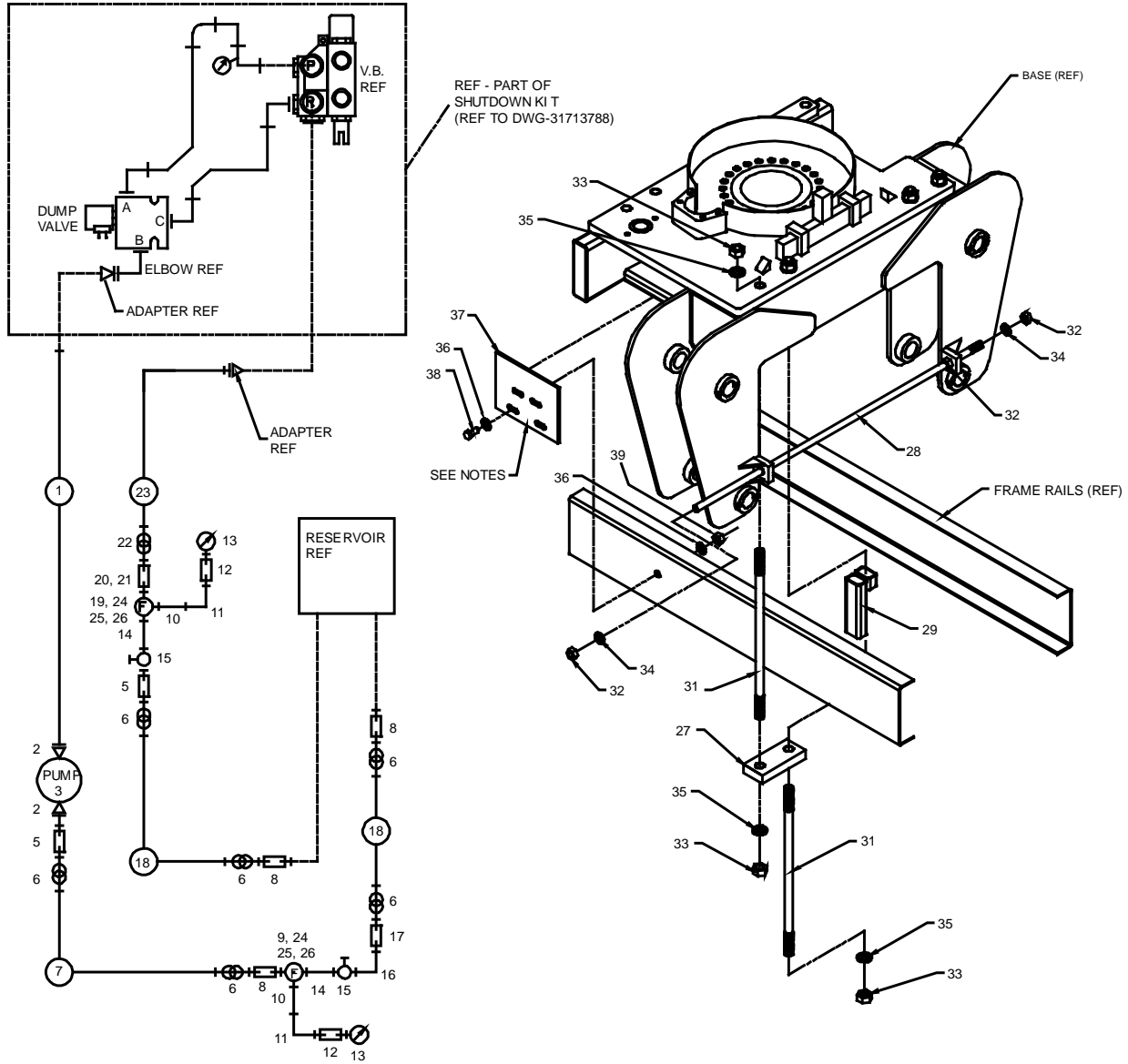

**NOTE:**

- 1 WELD ITEM 37 SHEAR PLATE TO BASE APPROXIMATELY AS SHOWN, WITH.38 BUTT WELD.
- 2 DRILL 0.812 HOLES AS REQUIRED TO BOLT ITEM 37 SHEAR PLATE TO FRAME RAILS.
- 3 NOT ALL PARTS ARE SHOWN FOR CLARITY.

93708876 PARTS LIST			
ITEM	PART #	DESCRIPTION	QTY
1.	51703703	HOSE ASM-TYPE FF .50X72.00	1
2.		ADAPTER-PUMP	2REF
3.		PUMP	1REF
5.	72532346	NIPPLE-BARB 90° 1.25 1.25	2



<b>93708876 PARTS LIST</b>			
ITEM	PART #	DESCRIPTION	QTY
6.	72661642	CLAMP – T-BOLT 1.75	6
7.	60035829	HOSE-1.25 100R4 X 48.00	1
8.	72531550	NIPPLE-BARB STL 1.25MPT 1.25	3
9.	73052012	FILTER-HYD SUC-100 MESH W/GAGE	1
10.	72053002	NIPPLE-PIPE BLK .12X 2.00	2
11.	72053281	ELBOW-STREET BLK .12X90	2
12.	72053301	COUPLING-BLK .12	2
13.	70048031	GAUGE-VACUUM GV10	2
14.	72053211	NIPPLE-PIPE BLK 1.25 CLOSE	2
15.	73054130	VALVE-GATE 1.25 BRASS	2
16.	72053287	ELBOW-STREET BLK 1.25X90DEG	1
17.	72531196	NIPPLE-BARB 45 DEG 1.25 1.25	1
18.	60035598	HOSE-1.25 100R4 X 72.00	2
19.	73052091	FILTER-HYD RET 10MIC 1.25 NPTF	1
20.	72532345	NIPPLE-BARB 90 DEG 1.00 1.00	1
21.	72053377	REDUCER BUSH-BLK 1.25-1.00	1
22.	72066515	CLAMP-HOSE 1.00 2-BOLT	1
23.	51396428	HOSE-J 1.00X 50 AOL (16)	1
24.	60103870	BRACKET-OIL FILTER	2
25.	72060025	CAP SCREW .31-18X 1.00 HH GR5 Z	4
26.	72062109	NUT .31-18 HEX NYLOC NZINC	4
27.	60010665	CLAMP PLATE-1.50X4.00 9.00	4
28.	60103204	STUD-TIE DOWN 1.00X44.00	1
29.	52716527	SUPPORT-WLDMT TRUCK FRAME 10.75	4
31.	71014847	STUD-TIE DOWN 1.25X28.50	8
32.	72062009	NUT 1.00-8 HEX ZINC	4
33.	72062142	NUT 1.25-7 HEX LOCK GR5	16
34.	72063058	WASHER 1.00 LOCK ZINC	2
35.	72063067	WASHER 1.25 HI STR ZINC	16
36.	72063119	WASHER .62 N FLAT H ASTM436Z	16
37.	60105107	SHEAR PLATE .38X10.00X13.00	2
38.	72060931	CAP SCREW .62-11 X 2.75 HH GR8 Z	8
39.	72062091	NUT .62-11 HEX NYLOC ZINC	8

# Decal Kit (95712299)

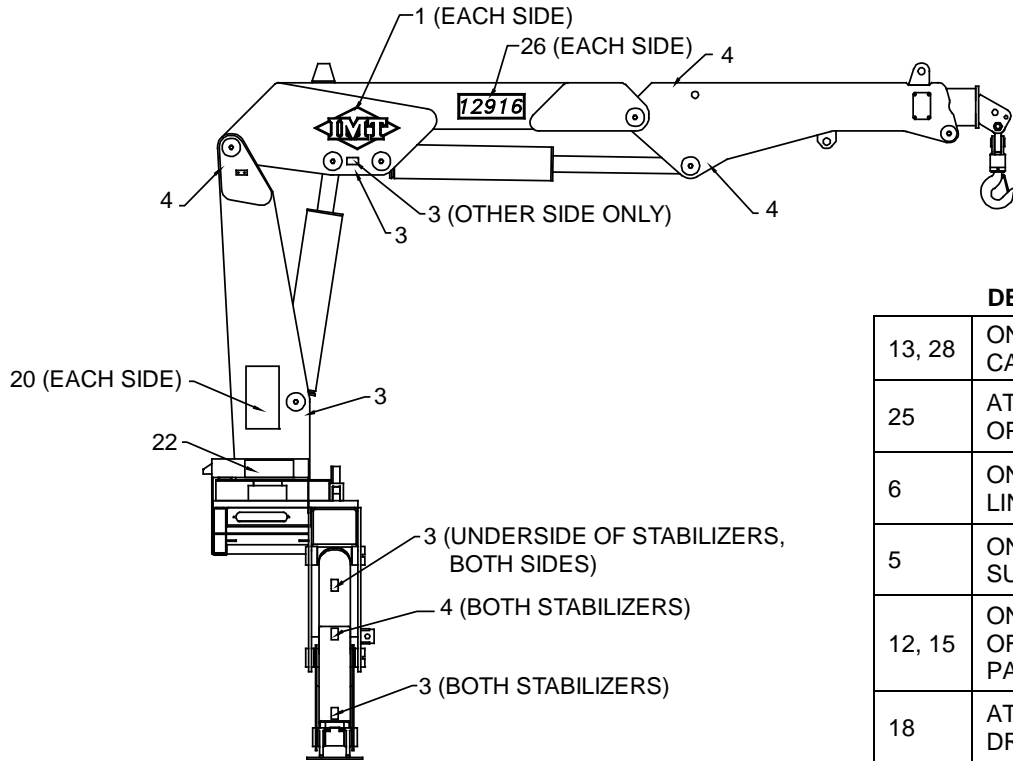

### DECAL PLACEMENT

13, 28	ONE ON EACH SIDE OF CARRIER VEHICLE
25	AT OR NEAR THE NORMAL OPERATING STATIONS
6	ON RESERVOIR AT RETURN LINE
5	ON RESERVOIR AT SUCTION LINE
12, 15	ONE ON THE UNDERSIDE OF EACH STABILIZER NEAR PAD
18	AT OR NEAR THE DRIVELINE
30	PLACE UNDER SERIAL TAG
31	ON FRONT SIDE OF BASE

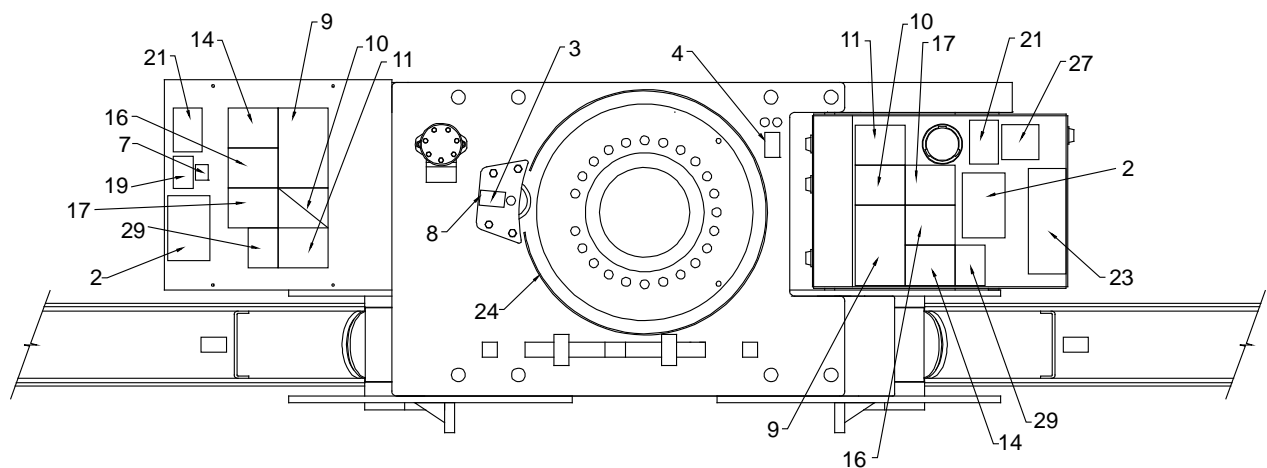

<b>95712299 PARTS LIST</b>			
ITEM	PART #	DESCRIPTION	QTY
1.	70029252	PLACARD-IMT DIAMOND 9.25X18.50	2
2.	70391583	DECAL-SET UP/STOW INSTRUCTIONS	2
3.	70391612	DECAL-GREASE WEEKLY (LEFT)	8
4.	70391613	DECAL-GREASE WEEKLY (RIGHT)	6
5.	70392108	DECAL-SUCTION LINE	1
6.	70392109	DECAL-RETURN LINE	1
7.	70392213	DECAL-CAUTION DON'T WASH/WAX	1
8.	70392524	DECAL-ROTATE CRANE WHILE GREASE	1
9.	70392813	DECAL-DANGER ELECTROCUTION	2
10.	70392814	DECAL-DANGER OPERATOR TRAINING	2
11.	70392815	DECAL-DANGER OPERATION	2
12.	70392864	DECAL-DANGER STAND CLEAR	2
13.	70392865	DECAL-DANGER ELEC HAZARD (LARGE)	4
14.	70392866	DECAL-DANGER OPER CONDITIONS	2
16.	70392888	DECAL-DANGER OPER RESTRICTIONS	2
17.	70392890	DECAL-DANGER TOWING/UNFOLDING	2
18.	70392891	DECAL-DANGER DRIVELINE	2
19.	70392982	DECAL-SERVICE & REPAIR (GARNER)	1
20.	71393869	PLACARD-CAPACITY 12916	2
21.	71039134	DECAL-CAUTION OIL LEVEL	2
22.	70395030	DECAL-CONTROL SS 7415-12916-425	1
23.	70395031	DECAL-CONTROL CS 7415-12916-425	1
24.	71392365	DECAL-ALIGNMENT CRANE ROTATION	1
25.	70392889	DECAL-DANGER RC ELECROCTN LG	2
26.	71393867	DECAL-12916 IDENTIFICATION	2
27.	70394189	PLACARD-MOBIL OIL RESERVOIR	1
28.	70392868	DECAL-DANGER CR LOADLINE (TRK)	4
29.	70392863	DECAL-DANGER HOISTING PERSONNEL	2
30.	70395323	DECAL-ASME/ANSI B30.22	1
31.	72042097	LEVEL INDICATOR	2
REV E 20120110			

## Capacity Alert Kit – 2800 PSI (31717169)

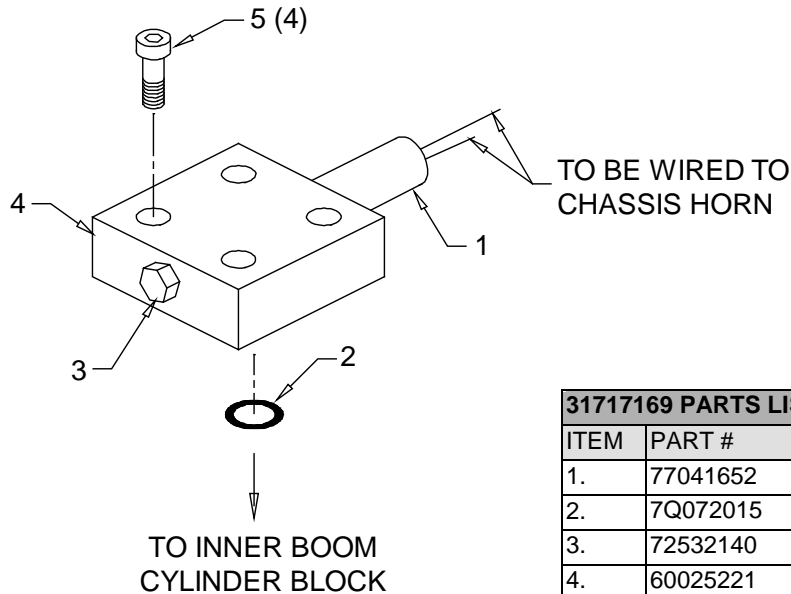

### 31717169 PARTS LIST

ITEM	PART #	DESCRIPTION	QTY
1.	77041652	PRESSURE SWITCH	1
2.	7Q072015	O-RING	1
3.	72532140	PLUG-9/16 STR HH	1
4.	60025221	MANIFOLD	1
5.	72060731	CAP SCREW 5/16-18 X 3/4 SH	4

REV A 20020702

## Capacity Shutdown Kit – 2800 PSI (31717514)

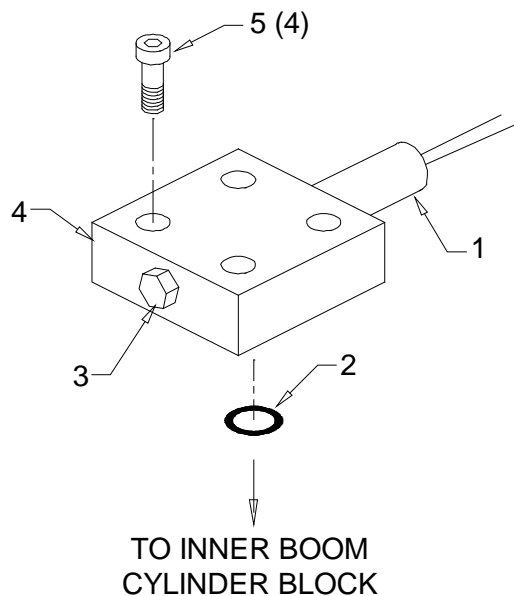

### 31717514 PARTS LIST

ITEM	PART #	DESCRIPTION	QTY
1.	77041543	PRESSURE SWITCH	1
2.	7Q072015	O-RING	1
3.	72532140	PLUG-STR HEX HS STL 9/16	1
4.	60025221	MANIFOLD	1
5.	72060731	CAP SCR 5/16-18 X 3/4 SH Z	4

REV A 20020702

## Light Kit – Crane Mast Mounted (51717977)

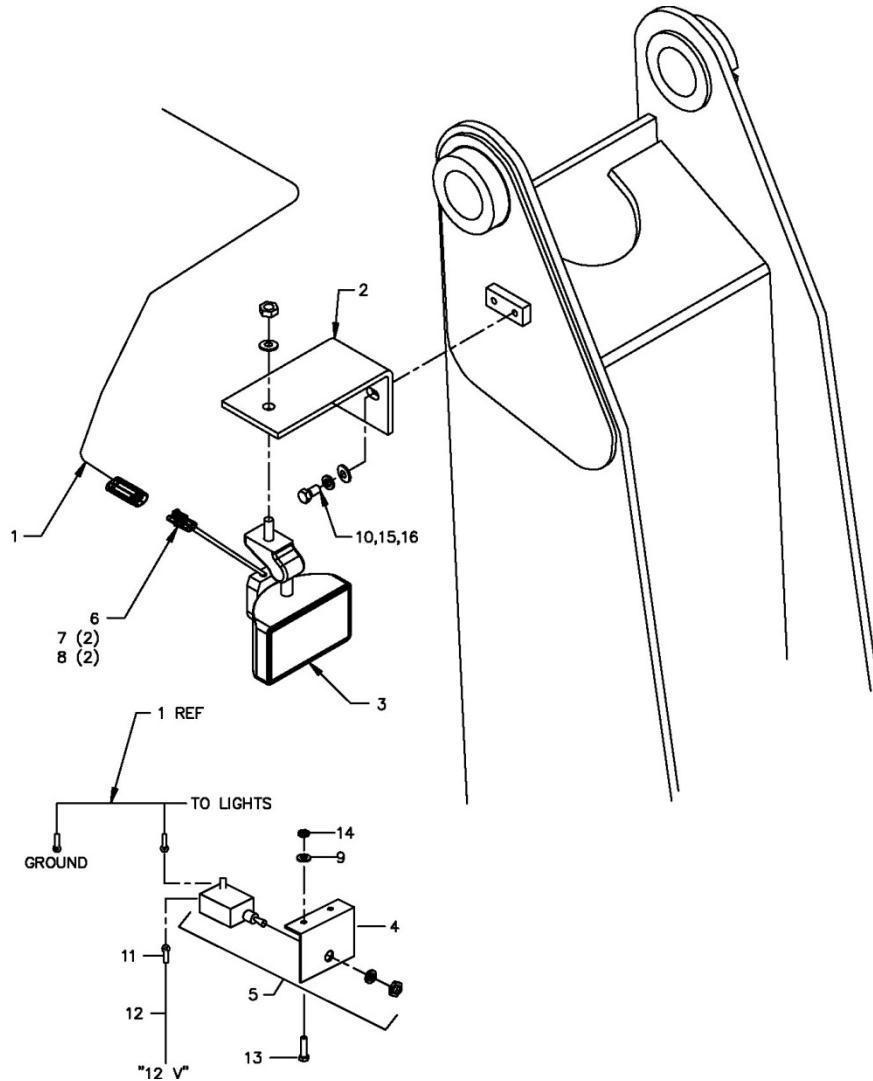

### 51717977 PARTS LIST

ITEM	PART #	DESCRIPTION	QTY
1.	51717219	CABLE ASM-FLOOD LIGHTS-ARTICULATING	1
2.	60113428	LIGHT BRACKET	2
3.	77040424	FLOODLIGHT-COMPOSITE WORK LAMP-TOP MTG	2
4.	60103535	SWITCH BRACKET-1HOLE	1
5.	77041345	TOGGLE SWITCH	1
6.	77044574	CONN-PKRD F 2-WAY WEATPK	2
7.	77044550	TERM-FEMALE18-20	4
8.	70394069	SEAL CABLE CONNECTOR	4
9.	72063049	WASHER .25 LOCK ZINC	2
10.	72060044	CAP SCREW .38-16X .75 HH GR5 Z	4
11.	77040000	TERMINAL, RING 1 #10 STUD 16-14 GA	1

<b>51717977 PARTS LIST</b>			
ITEM	PART #	DESCRIPTION	QTY
12.	89044274	WIRE-BLACK STRD TYPE GPT	36"
13.	72060000	CAP SCREW .25-20 X .50 HH GR5 Z	2
14.	72062000	NUT .25-20 HEX ZINC	2
15.	72063051	WASHER .38 LOCK ZINC	4
16.	72063003	WASHER .38 W FLAT	4
REV A 20070327			

# Hydraulic Shutdown Kit (31713788)

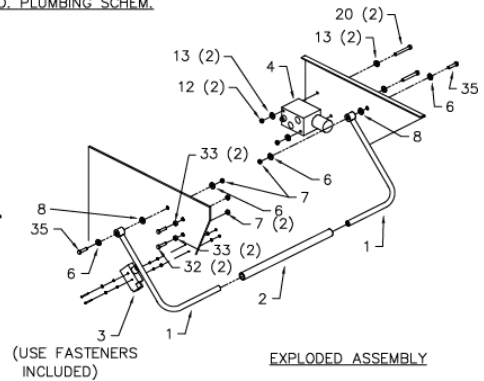
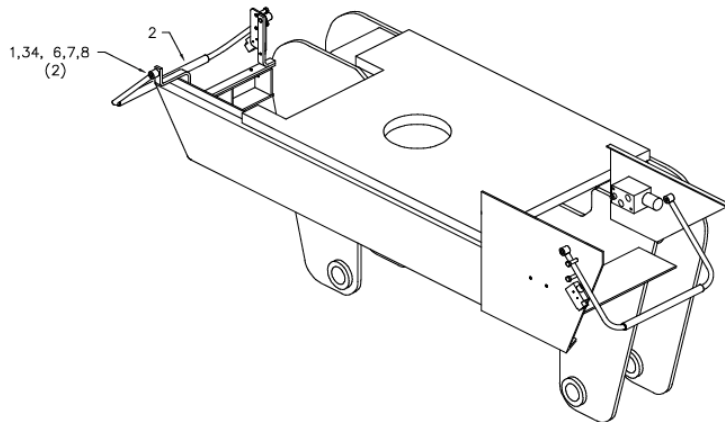
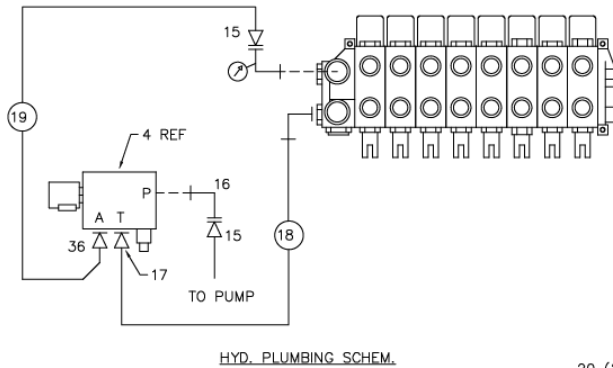
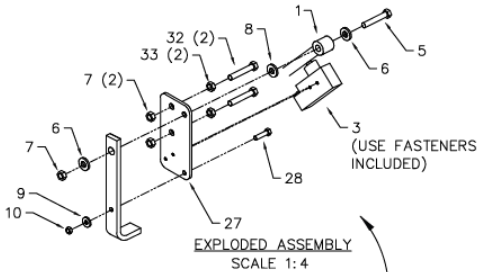
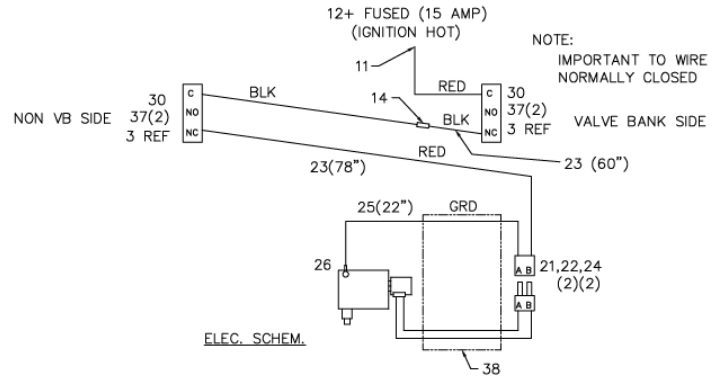
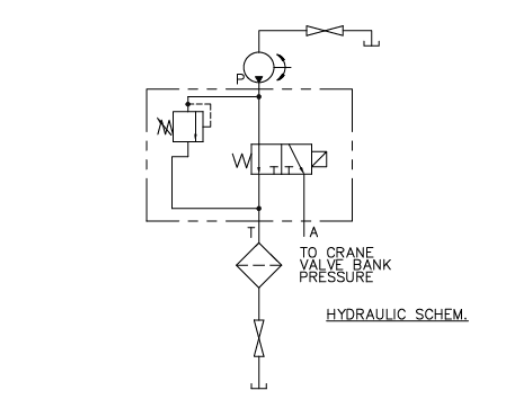

31713788 PARTS LIST			
ITEM	PART #	DESCRIPTION	QTY
1.	52713782	HANDLE – SHUTDOWN	A/R
2.	60120092	TUBE - .75X1.00X15.50	A/R
3.	77041459	LIMIT SWITCH	2
4.	VARIABLES	VALVE ASM – RELIEF/SOL HYD SHUTD	1
5.	72060052	CAP SCREW - .38-16 X 2.50 HH GR5	1
6.	72063003	WASHER - .38 W FLAT	8

<b>31713788 PARTS LIST</b>			
ITEM	PART #	DESCRIPTION	QTY
7.	72062103	NUT .38-16 NYLOC	8
8.	72063215	WASHER – BELLEVILLE .38 SS	4
9.	72063001	WASHER .25 W FLAT	1
10.	72062104	NUT - .25-20 NYLOC	4
11.	77040282	TERM-PIGBAC FVD 16/14GA .25TAB	1
12.	72062109	NUT - .31-18 NYLOC	4
13.	72063002	WASHER .31 WRT	4
14.	77040048	TERM-BUTT CONNECTOR 16-14GA	1
15.	72532972	ADAPTER – MJIC/FJIC #8 #12	2
16.	72053767	ELBOW – MSTR/90/MJIC #12 #12	1
17.	72532366	ADAPTER-M STR/MJIC #12 #12	1
18.	51394919	HOSE-FF .75X21.00 OAL (12-12)	1
19.	51394882	HOSE-FI .50X22.00 OAL (8-8)	1
20.	72060038	CAP SCREW - .31-18X4.50 HH GR5 Z	2
21.	77044573	CONNECTOR, M 2-WAY WP	1
22.	77044552	TERMINAL-MALE 18-20GA WP	2
23.	89044188	CABLE-14AWG DUPLEX AUTO PRIMARY	12 FT
24.	70394069	SEAL-CABLE CONNECTOR WP	2
25.	89044274	WIRE – 14GA BLK STRD	2 FT
26.	77040052	TERM-RING .38 STUD 12-10 GA	1
27.	60120438	BRACKET – LIMIT SWITCH	1
28.	72060004	CAP SCREW - .25-20 X 1.00 HH GR5	1
30.	77044468	CONNECTOR - .50 STR RLF .12-.25	2
32.	72060050	CAP SCREW - .38-16 X 2.25 HH GR5 Z	1
33.	72062002	NUT - .38-16 HEX ZINC	4
34.	72060030	CAP SCREW .31-18 X 2.25 HH GR5 Z	1
35.	72060031	CAP SCREW .31-18 X 2.00 HH GR5 Z	2
36.	72532360	ADAPTER-M STR/M JIC #12 #8	1
37.	77040051	TERM-SPRSPADE #8 STUD 16-14	4
38.	89034048	SPIRAL WRAP-CLEAR	3 FT
REV H 20140415			



---

## Option – Hook Assembly Kit (40726070)

40726070 PARTS LIST			
ITEM	PART #	DESCRIPTION	QTY
1.	60142343	PIN-TYPE NN 1.25 X 5.75	1
2.	71415014	KEEPER-PIN .38	1
3.	72063003	WASHER-FLAT .38 W	1
4.	72060047	CAP SCR .38-16 X 1.25 HH GR5 Z	1
5.	70731813	HOOK-SWVL 7EH W3214 LCH ASM	1
6.	72661245	SHACKLE-8.5 TON 1.00 NOM SIZE	1

## 12916 Recommended Spare Parts List

This parts list is intended to provide the user with a stock of parts sufficient to keep the unit operating with the minimal down-time waiting for parts, but it does not indicate these items will fail within a year. In addition, there may be parts failures not covered by this list. Parts not listed are considered as not being Critical or Normal Wear items during the first year of operations.

ASSEMBLY DESCRIPTION		
PART #	SPARE PART DESCRIPTION	MANUAL PAGE REFERENCE
STABILIZER CYLINDER (3C283801)		
73054304	COUNTERBALANCE VALVE	26
9C242432	SEAL KIT	26
INNER CYLINDER (3C194614)		
73054242	VALVE 25GPM	29
9C282835	SEAL KIT	29
OUTER CYLINDER (3C195613)		
73054242	VALVE 25GPM	32
9C262832	SEAL KIT	32
EXTENSION CYLINDER (51718065)		
73540052	VALVE	34
9C121617	SEAL KIT	34
RELIEF VALVE ASSEMBLY		
77040456	COIL FOR 12V RADIO	39
77040447	COIL FOR 24V RADIO	39
73054980	12V DUMP VALVE	39
77041456	COIL FOR 12V DUMP VALVE	39
73540142	24V DUMP VALVE	39
77040463	COIL FOR 24V DUMP VALVE	39
HYDRAULIC OVERLOAD KIT, 3-FUNCTION (51717130)		
77441576	COIL FOR VALVE BLK 73540463	46
ELECTRICAL CONTROL BOX ASSEMBLY		
77041500	SWITCH, ROCKER BODY 12V	50
77041672	SWITCH, ROCKER BODY 24V	50
77041499	SWITCH, ROCKER ACTUATOR	50
77041571	SWITCH, ROCKER PLUG	50
77041251	RELAY 40 AMP (12V)	50
77041674	RELAY 20 AMP (24V)	50
77040391	RELAY 12V DC 75 AMP	50
77040455	RELAY 24V DC 50 AMP	50
77041599	RELAY 12V	50
77041677	RELAY 24V	50

## CHAPTER 5

# General Reference

## In This Chapter

Inspection Checklist.....	65
Deficiency/Recommendation/Corrective Action Report.....	70
Turntable Bearing Thread Tightening Sequence .....	75
Turntable Bearing Inspection.....	76
Thread Torque Chart (English) .....	78
Thread Torque Chart (Metric) .....	79

---

## Inspection Checklist

### NOTICE:

The user of this form is responsible for determining that these inspections satisfy all applicable regulatory requirements.

---

OWNER/COMPANY:	TYPE OF INSPECTION (circle one):			
CONTACT PERSON:	DAILY	MONTHLY	QUARTERLY	ANNUAL
CRANE MAKE & MODEL:	DATE INSPECTED:			
CRANE SERIAL NUMBER:	HOURMETER READING (if applicable):			
UNIT I.D. NUMBER:	INSPECTED BY (print):			
LOCATION OF UNIT:	SIGNATURE OF INSPECTOR:			

## TYPE OF INSPECTION

## NOTES:

Daily and monthly inspections are to be performed by a "competent person", who is capable of identifying existing and predictable hazards in the surroundings or working conditions which are unsanitary, hazardous, or dangerous to employees, and who has authorization to take prompt corrective measures to eliminate them.

Quarterly and annual inspections are to be performed by a "qualified person" who, by possession of a recognized degree, certificate, or professional standing, or who by extensive knowledge, training and experience, successfully demonstrated the ability to solve/resolve problems relating to the subject matter, the work, or the project.

One hour of normal crane operation assumes 20 complete cycles per hour. If operation exceeds 20 cycles per hour, inspection frequency should be increased accordingly.

Consult Operator / Service Manual for additional inspection items, service bulletins and other information.

Before inspecting and operating crane, crane must be set up away from power lines and leveled with stabilizers fully extended.

DAILY (D): Before each shift of operation, those items designated with a (D) must be inspected.

MONTHLY (M): Monthly inspections or 100 hours of normal operation (whichever comes first) includes all daily inspections plus items designated with an (M). This inspection must be recorded and retained for a minimum of 3 months.

QUARTERLY (Q): Every three to four months or 300 hours of normal operation (whichever comes first) includes all daily and monthly inspection items plus items designated with a (Q). This inspection must be documented, maintained, and retained for a minimum of 12 months, by the employer that conducts the inspection.

ANNUAL (A): Each year or 1200 hours of normal operation (whichever comes first) includes all items on this form which encompasses daily, monthly and quarterly inspections plus those items designated by (A). This inspection must be documented, maintained, and retained for a minimum of 12 months, by the employer that conducts the inspection.

## INSPECTION CHECKLIST STATUS KEY:

S = Satisfactory	X = Deficient
R = Recommendation (Should be considered for corrective action)	(NOTE: If a deficiency is found, an immediate determination must be made as to whether the deficiency constitutes a safety hazard and must be corrected prior to operation.)
NA = Not Applicable	

FREQUENCY	ITEM	KEY	INSPECTION DESCRIPTION	STATUS (S,R,X,NA)
D	1	Labels	All load charts, safety & warning labels, and control labels are present and legible.	
D	2	Crane	Check all safety devices for proper operation.	
D	3	Controls	Control mechanisms for proper operation of all functions, leaks and cracks.	
D	4	Station	Control and operator's station for dirt, contamination by lubricants, and foreign material.	
D	5	Hydraulic System	Hydraulic system (hoses, tubes, fittings) for leakage and proper oil level.	
D	6	Hook	Presence and proper operation of hook safety latches.	
D	7	Wire Rope	Inspect for apparent deficiencies per applicable requirements and manufacturer's specifications.	

FREQUENCY	ITEM	KEY	INSPECTION DESCRIPTION	STATUS
				(S,R,X,NA)
D	8	Pins	Proper engagement of all connecting pins and pin retaining devices.	
D	9	General	Overall observation of crane for damaged or missing parts, cracked welds, and presence of safety covers.	
D	10	Operation	During operation, observe crane for abnormal performance, unusual wear (loose pins, wire rope damage, etc.). If observed, discontinue use and determine cause and severity of hazard.	
D	11	Remote Ctrl	Operate remote control devices to check for proper operation.	
D	12	Electrical	Operate all lights, alarms, etc. to check for proper operation.	
D	13	Anti-Two-Block or Two-Block Damage Prevention	Operate anti two-block or two-block damage prevention device to check for proper operation.	
D	14	Tires	Check tires (when in use) for proper inflation and condition.	
D	15	Ground Conditions	Check ground conditions around the equipment for proper support, watching for ground settling under and around stabilizers and supporting foundations, ground water accumulation, or similar conditions.	
D	16	Level	Check the equipment for level position within the tolerances specified by the equipment manufacturer's recommendations, both before each shift and after each move and setup.	
D	17	Operator cab windows	Check windows for cracks, breaks, or other deficiencies which would hamper the operator's view.	
D	18	Rails, rail stops, rail clamps and supporting surfaces	Check rails, rail stops, rail clamps and supporting surfaces when the equipment has rail traveling.	
D	19	Safety devices	Check safety devices and operational aids for proper operation.	
D	20	Electrical	Check electrical apparatus for malfunctioning, signs of apparent excessive deterioration, dirt or moisture accumulation.	
D	21		Other	
D	22		Other	
M	23	Daily	All daily inspection items.	
M	24	Cylinders	Visual inspection of cylinders for leakage at rod, fittings, and welds. Damage to rod and case.	
M	25	Valves	Holding valves for proper operation.	
M	26	Valves	Control valves for leaks at fittings and between stations.	
M	27	Valves	Control valve linkages for wear, smoothness of operation, and tightness of fasteners. Relief valve for proper pressure settings.	
M	28	General	Bent, broken, or significantly rusted/corroded parts.	
M	29	Electrical	Electrical apparatus for malfunctioning, signs of apparent excessive deterioration, dirt or moisture accumulation. Electrical systems for presence of dirt, moisture, and frayed wires.	
M	30	Structure	All structural members for damage.	
M	31	Welds	All welds for breaks and cracks.	
M	32	Pins	All pins for proper installation and condition.	
M	33	Hardware	All bolts, fasteners and retaining rings for tightness, wear and corrosion.	
M	34	Wear Pads	Presence of wear pads.	
M	35	Pump & Motor	Hydraulic pumps and motors for leakage at fittings, seals, and between sections. Check tightness of mounting bolts.	

FREQUENCY	ITEM	KEY	INSPECTION DESCRIPTION	STATUS (S,R,X,NA)
M	36	PTO	Transmission/PTO for leakage, abnormal vibration & noise, alignment, and mounting bolt torque.	
M	37	Hyd Fluid	Quality of hydraulic fluid and presence of water.	
M	38	Hyd Lines	Hoses & tubes for leakage, abrasion damage, blistering, cracking, deterioration, fitting leakage, and secured properly.	
M	39	Hook	Load hook for abnormal throat distance, twist, wear, and cracks.	
M	40	Wire Rope	Condition of load line.	
M	41	Manual	Presence of operator's manual with unit.	
M	42		Other	
M	43		Other	
Q	44	Daily	All daily inspection items.	
Q	45	Monthly	All monthly inspection items.	
Q	46	Rotation Sys	Rotation bearing for proper torque of all mounting bolts.	
Q	47	Hardware	Base mounting bolts for proper torque.	
Q	48	Structure	All structural members for deformation, cracks and corrosion.	
	49		• Base	
	50		• Stabilizer beams and legs	
	51		• Mast	
	52		• Inner Boom	
	53		• Outer Boom	
	54		• Extension(s)	
	55		• Jib boom	
	56		• Jib extension(s)	
	57		• Other	
Q	58	Hardware	Pins, bearing, shafts, gears, rollers, and locking devices for wear, cracks, corrosion and distortion.	
	59		• Rotation bearing(s)	
	60		• Inner boom pivot pin(s) and retainer(s)	
	61		• Outer boom pivot pin(s) and retainer(s)	
	62		• Inner boom cylinder pin(s) and retainer(s)	
	63		• Outer boom cylinder pin(s) and retainer(s)	
	64		• Extension cylinder pin(s) and retainer(s)	
	65		• Jib boom pin(s) and retainer(s)	
	66		• Jib cylinder pin(s) and retainer(s)	
	67		• Jib extension cylinder pin(s) and retainer(s)	
	68		• Boom tip attachment	
	69		• Other	
Q	70	Hyd Lines	Hoses, fittings and tubing for proper routing, leakage, blistering, deformation and excessive abrasion.	
	71		• Pressure line(s) from pump to control valve	
	72		• Return line(s) from control valve to reservoir	
	73		• Suction line(s) from reservoir to pump	
	74		• Pressure line(s) from control valve to each function	
	75		• Load holding valve pipe(s) and hose(s)	
	76		• Other	
Q	77	Pumps & Motors	Pumps and Motors for loose bolts/fasteners, leaks, noise, vibration, loss of performance, heating & excess pressure.	
	78		• Winch motor(s)	
	79		• Rotation motor(s)	
	80		• Other	

FREQUENCY	ITEM	KEY	INSPECTION DESCRIPTION	STATUS
				(S,R,X,NA)
Q	81	Valves	Hydraulic valves for cracks, spool return to neutral, sticking spools, proper relief valve setting, relief valve failure.	
	82		• Main control valve	
	83		• Load holding valve(s)	
	84		• Stabilizer or auxiliary control valve(s)	
	85		• Other	
	86		• Other	
Q	87	Cylinders	Hydraulic cylinders for drifting, rod seal leakage and leakage at welds. Rods for nicks, scores and dents. Case for damage. Case and rod ends for damage and abnormal wear.	
	88		• Stabilizer cylinder(s)	
	89		• Inner boom cylinder(s)	
	90		• Outer boom cylinder(s)	
	91		• Extension cylinder(s)	
	92		• Rotation cylinder(s)	
	93		• Jib lift cylinder(s)	
	94		• Jib extension cylinder(s)	
	95		• Other	
Q	96	Winch	Winch, sheaves and drums for damage, abnormal wear, abrasions and other irregularities.	
Q	97	Hyd Filters	Hydraulic filters for replacement per maintenance schedule.	
A	98	Daily	All daily inspection items.	
A	99	Monthly	All monthly inspection items.	
A	100	Quarterly	All quarterly inspection items.	
A	101	Hyd Sys	Hydraulic fluid change per maintenance schedule.	
A	102	Controls	Control valve calibration for correct pressure & relief valve settings.	
A	103	Valves	Safety valve calibration for correct pressure & relief valve settings.	
A	104	Valves	Valves for failure to maintain correct settings.	
A	105	Rotation Sys	Rotation drive system for proper backlash clearance & abnormal wear, deformation and cracks.	
A	106	Lubrication	Gear oil change in rotation drive system per maintenance schedule.	
A	107	Hardware	Check tightness of all fasteners and bolts, using torque specifications on component drawings or torque chart.	
A	108	Wear Pads	Wear pads for excessive wear.	
A	109	Loadline	Loadline for proper attachment to drum.	







**WIRE ROPE INSPECTION**

Wire rope with any of the deficiencies shown below shall be removed and replaced immediately.

- A. Corrosion can be cause for replacement. Any development of corrosion must be noted and monitored closely.
- B. When there are either 3 broken wires in one strand or a total of six broken wires in all strands in any one rope lay.

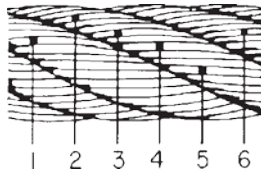

- C. When flat spots on the outer wires appear and those outside wires are less than 2/3 the thickness of the unworn outer wire.

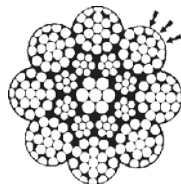

- D. When there is a decrease of diameter indicating a core failure.

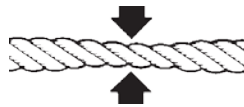

- E. When kinking, crushing, birdcaging or other distortion occurs.

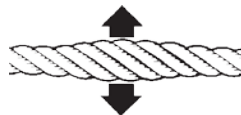

- F. When there is noticeable heat damage (discoloration) of the rope by any means.



- G. When the diameter is reduced from nominal size by 1/32" or more.



- H. If a broken wire protrudes or loops out from the core of the rope.



## HOOK INSPECTION

Hooks having any of the listed deficiencies shall be removed from service unless a qualified person approves their continued use and initiates corrective action. Hooks approved for continued use shall be subjected to periodic inspection.

### A. DISTORTION

#### Bending / Twisting

A bend or twist exceeding 10° from the plane of the unbent hook.

#### Increased Throat Opening

HOOK WITHOUT LATCH: An increase in throat opening exceeding 15%. (Or as recommended by the manufacturer)

HOOK WITH LATCH: An increase of the dimension between a fully-opened latch and the tip section of the hook exceeding 8%. (Or as recommended by the manufacturer)

### B. WEAR

If wear exceeds 10% of the original sectional dimension. (Or as recommended by the manufacturer)

### C. CRACKS, NICKS, GOUGES

Repair of cracks, nicks, and gouges shall be carried out by a designated person by grinding longitudinally, following the contour of the hook, provided that no dimension is reduced more than 10% of its original value. (Or as recommended by the manufacturer) (A qualified person may authorize continued use if the reduced area is not critical.)

### D. LATCH

#### Engagement, Damage & Malfunction

If a latch becomes inoperative because of wear or deformation, and is required for the service involved, it shall be replaced or repaired before the hook is put back into service. If the latch fails to fully close the throat opening, the hook shall be removed from service or "moused" until repairs are made.

### E. HOOK ATTACHMENTS & SECURING MEANS

If any indication of distortion, wear, cracks, nicks or gouges are present, unless a qualified person authorizes their use. (Or as recommended by the manufacturer)

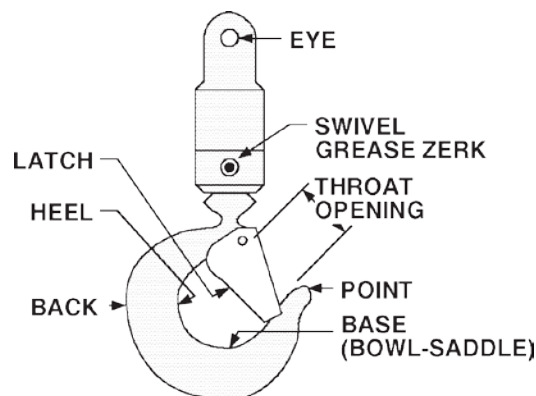

**HOLDING VALVE INSPECTION**

The cylinders are equipped with holding valves that prevent sudden movement of the cylinder rods in the event of a hydraulic hose or other hydraulic component failure. The valve is checked in the following manner:

1. With a full rated load, extend the cylinder in question and kill the engine.
2. Operate the control valve to retract the cylinder. If the cylinder “creeps”, replace the holding valve. If the cylinder does not “creep”, the valve is serviceable.

**TWO BLOCK PREVENTION DEVICE INSPECTION**

**(See Vol. 1, Operation, Maintenance and Repair for a complete description)**

The two block prevention system halts the “winch-up” and “extension-out” crane functions before the block contacts the sheave. The two block prevention system should be checked daily as follows:

1. Examine flexible rod and weight to insure free unrestricted mechanical operation
2. Examine cord for damage, cuts or breaks. Grasp cord and pull to check operation of cord reel. The cord should retract on reel when released.
3. Start vehicle, engage PT O and slowly winch loadline up until anti-two block weight comes in contact with the hook end of the loadline cable. At the moment the weight is fully supported by the hook end, the winch up function should become non-functioning, because the two-block damage prevention switch will stop further movement.

If operation other than as described occurs, stop immediately and investigate. Failure to do so will risk damage to the cable or the crane.

Then, extend the winch cable to relieve the two-block condition, and actuate the boom extend function slowly. Again, once the weight is fully supported by the hook end, the boom extend function should become non-functioning, because the two-block damage prevention switch will stop further movement. If operation other than described occurs, stop immediately, reverse the function, and check the system.

If the anti-two block function appears to be functioning normally, winch the cable down until the sensing weight swings free.

## Turntable Bearing Thread Tightening Sequence

Refer to the turntable bearing thread tightening diagram below for proper tightening/torqueing sequence of the turntable bearing to the crane base and crane mast. The total quantity of cap screws varies dependent on crane model.

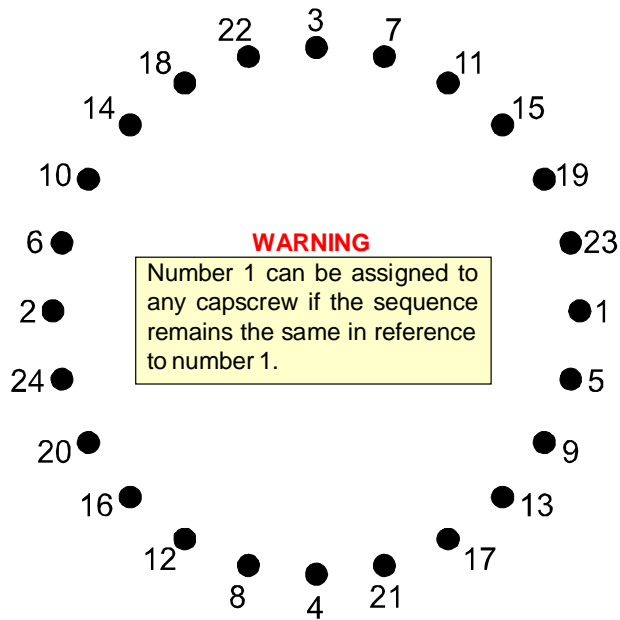

### TIGHTENING PROCEDURE

- 1 Refer to the Torque Data Chart to determine the proper torque value to apply to the size of capscrew used.
- 2 Follow the tightening sequence shown in the diagram. Note that the quantity of capscrews may differ from the diagram, but the sequence must follow the criss-cross pattern as shown in the diagram.
- 3 Torque all capscrews to approximately 40% of the specified torque value, by following the sequence.  
(EXAMPLE:  $.40 \times 265 \text{ FT-LB} = 106 \text{ FT-LB}$ )  
(EXAMPLE-METRIC:  $.40 \times 36 \text{ KG-M} = 14.4 \text{ KG-M}$ )
- 4 Repeat Step 3, but torquing all capscrews to 75% of the specified torque value. Continue to follow the tightening sequence.  
(EXAMPLE:  $.75 \times 265 \text{ FT-LB} = 199 \text{ FT-LB}$ )  
(EXAMPLE-METRIC:  $.75 \times 36 \text{ KG-M} = 27 \text{ KG-M}$ )
- 5 Using the proper sequence, torque all capscrews to the listed torque value as determined from the Torque Data Chart.

---

## Turntable Bearing Inspection

Turntable bearings may experience wear. One of the following conditions may indicate turntable bearing wear.

- 1 Metal particles present in the bearing lubricant.
- 2 Increased drive power required to rotate the crane.
- 3 Noise emitting from the bearing during rotation.
- 4 Rough rotation.
- 5 Uneven or excessive wear between the pinion gear and turntable gear.

If none of the above conditions exists, the bearing is functioning properly and need not be replaced. But, if one or more of the above conditions exists, inspection may be required. Limits are measured in "TILT" which is dependent on the internal clearances of the bearing. TILT is the most practical determination of a bearings internal clearance once mounted on a crane.

Periodic readings indicating a steady increase in TILT may be an indicator of bearing wear. Note that a bearing found to have no raceway cracks or other structural irregularities should be reassembled and returned to service.

---

### TEST PROCEDURE

1. Place crane in vertical position.
2. Set a dial indicator at 0 on the pinion cover plate at back side of mast.
3. Lower crane to the horizontal position.
4. Check and record the dial indicator change. It should not exceed the tilt measurement noted in the chart below.
5. Return the crane to the vertical position. The dial indicator should return to 0.

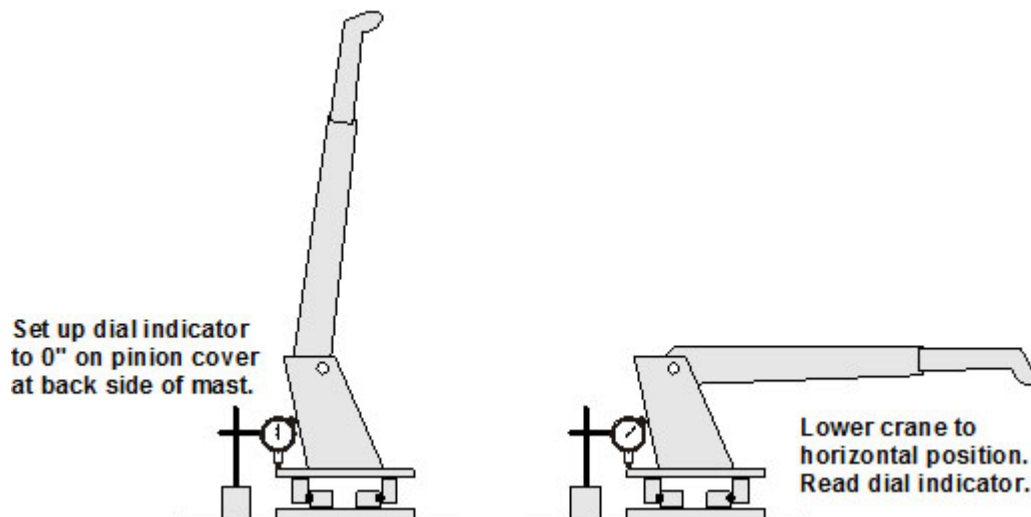

<b>COMPARISON CHART - MODEL TO MEASURED TILT DIMENSION</b>					
<p><b>NOTE</b> THE FIGURES LISTED IN THIS CHART ARE SERVICE GUIDELINES AND DO NOT, IN THEMSELVES, REQUIRE THAT THE BEARING BE INSPECTED.</p> <p>IF THERE IS REASON TO SUSPECT AN EXCESS OF BEARING WEAR AND THE MEASURED TILT DIMENSION EXCEEDS THE DIMENSION LISTED, REMOVE THE BEARING FOR INSPECTION.</p>	<p><b>IMT CRANE, LOADER OR TIREHAND MODEL</b></p>	1007	5200	16035	9800
		1014	5200R	16042	12916
		2015	5217	32018	13031
	2015GH	5800	32030	13034	14000
	2109	7020	T30	15000	18000
	2200	7025	T40	20017	H1200
	3000	7200		H1200RR	T50
	3016	7415		TH2551B BODY ROT'N	TH2557B BODY ROT'N
	321GH	9000		TH2557A BODY ROT'N	
	3816	TH10 BODY ROT'N			
	425	TH14 BODY ROT'N			
	4300				
	5016				
	6016				
	TH7 BODY ROT'N				
	TH1449 BODY ROT'N				
	TH15B CLAMP				
	TH2551B CLAMP				
	TH2557A CLAMP				
	<b>BALL DIA. (REF)</b>	.875" (22mm)	1.00" (25mm)	1.18"-1.25" (30-32mm)	1.75" (44mm)
	<b>TILT DIM. (A<sub>1</sub>-A<sub>2</sub>)</b>	.060" (1.524mm)	.070" (1.778mm)	.075" (1.905mm)	.090" (2.286mm)

## Thread Torque Chart (English)

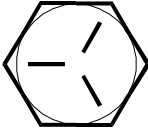
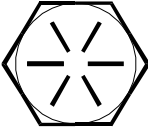
FINE THREAD BOLTS (ENGLISH)					
SIZE	BOLT DIA.	GRADE 5		GRADE 8	
					
		SAE J429 GRADE 5		SAE J429 GRADE 8	
(DIA-TPI)	(INCHES)	PLAIN	PLATED	PLAIN	PLATED
		(FT-LB)	(FT-LB)	(FT-LB)	(FT-LB)
5/16-24	0.3125	19	14	27	20
3/8-24	0.375	35	26	49	35
7/16-20	0.4375	55	41	78	58
1/2-20	0.5	90	64	120	90
9/16-18	0.5625	120	90	170	130
5/8-18	0.625	170	130	240	180
3/4-16	0.75	300	225	420	315
7/8-11	0.875	445	325	670	500
1-12	1	645	485	995	745
1 1/8-12	1.125	890	670	1445	1085
1 1/4-12	1.25	1240	930	2010	1510
1 3/8-12	1.375	1675	1255	2710	2035
1 1/2-12	1.5	2195	1645	3560	2670

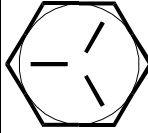
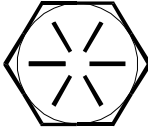
COARSE THREAD BOLTS (ENGLISH)					
SIZE	BOLT DIA.	GRADE 5		GRADE 8	
					
		SAE J429 GRADE 5		SAE J429 GRADE 8	
(DIA-TPI)	(INCHES)	PLAIN	PLATED	PLAIN	PLATED
		(FT-LB)	(FT-LB)	(FT-LB)	(FT-LB)
5/16-18	0.3125	17	13	25	18
3/8-16	0.375	31	23	44	33
7/16-14	0.4375	49	37	70	52
1/2-13	0.5	75	57	105	80
9/16-12	0.5625	110	82	155	115
5/8-11	0.625	150	115	220	160
3/4-10	0.75	265	200	375	280
7/8-9	0.875	395	295	605	455
1-8	1	590	445	910	680
1 1/8-7	1.125	795	595	1290	965
1 1/4-7	1.25	1120	840	1815	1360
1 3/8-6	1.375	1470	1100	2380	1780
1 1/2-6	1.5	1950	1460	3160	2370

### NOTES



- 1 Tightening torques provided are midrange.
- 2 Consult bolt manufacturer's particular specifications, when provided.
- 3 Use flat washers of equal strength.
- 4 All torque measurements are given in foot-pounds.
- 5 Torque values specified are for bolts with residual oils or no special lubricants applied. If special lubricants of high stress ability, such as Never-Seez compound graphite and oil, molybdenum disulphide, colloidal copper or white lead are applied, multiply the torque values in the charts by the factor .90. The use of Loctite does not affect the torque values listed above.



### WARNING

Anytime a gear-bearing bolt is removed, it must be replaced with a new bolt of the identical grade and size. Once a bolt has been torqued to 75% of its proof load and then removed, the torque coefficient may no longer be the same as when the bolt was new thus giving indeterminate clamp loads after torquing. Failure to replace gear-bearing bolts may result in bolt failure due to metal fatigue causing death or serious injury.

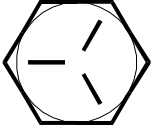

## Thread Torque Chart (Metric)

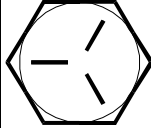
FINE THREAD TORQUE CHART (METRIC)					
TIGHTENING TORQUE					
SIZE (DIA-TPI)	BOLT DIA. (INCHES)	 SAE J429 GRADE 5		 SAE J429 GRADE 8	
		PLAIN (KG-M)	PLATED (KG-M)	PLAIN (KG-M)	PLATED (KG-M)
5/16-24	0.3125	3	2	4	3
3/8-24	0.375	5	4	7	5
7/16-20	0.4375	8	6	11	8
1/2-20	0.5	12	9	17	12
9/16-18	0.5625	17	12	24	18
5/8-18	0.625	24	18	33	25
3/4-16	0.75	41	31	58	44
7/8-11	0.875	62	45	93	69
1-12	1	89	67	138	103
1 1/8-12	1.125	123	93	200	150
1 1/4-12	1.25	171	129	278	209
1 3/8-12	1.375	232	174	375	281
1 1/2-12	1.5	304	228	492	369

COARSE THREAD TORQUE CHART (METRIC)					
TIGHTENING TORQUE					
SIZE (DIA-TPI)	BOLT DIA (INCHES)	 SAE J429 GRADE 5		 SAE J429 GRADE 8	
		PLAIN (KG-M)	PLATED (KG-M)	PLAIN (KG-M)	PLATED (KG-M)
5/16-18	0.3125	2	2	3	2
3/8-16	0.375	4	3	6	5
7/16-14	0.4375	7	5	10	7
1/2-13	0.5	10	8	15	11
9/16-12	0.5625	15	11	21	16
5/8-11	0.625	21	16	30	22
3/4-10	0.75	37	28	52	39
7/8-9	0.875	55	41	84	63
1-8	1	82	62	126	94
1 1/8-7	1.125	110	82	178	133
1 1/4-7	1.25	155	116	251	188
1 3/8-6	1.375	203	152	329	246
1 1/2-6	1.5	270	210	438	328

### NOTES

- 1 Tightening torques provided are midrange.
- 2 Consult bolt manufacturer's particular specifications, when provided.
- 3 Use flat washers of equal strength.
- 4 All torque measurements are given in kilogram-meters.
- 5 Torque values specified are for bolts with residual oils or no special lubricants applied. If special lubricants of high stress ability, such as Never-Seez compound graphite and oil, molybdenum disulphite, colloidal copper or white lead are applied, multiply the torque values in the charts by the factor .90. The use of Loctite does not affect the torque values listed above.

### WARNING

Anytime a gear-bearing bolt is removed, it must be replaced with a new bolt of the identical grade and size. Once a bolt has been torqued to 75% of its proof load and then removed, the torque coefficient may no longer be the same as when the bolt was new thus giving indeterminate clamp loads after torqueing. Failure to replace gear-bearing bolts may result in bolt failure due to metal fatigue causing death or serious injury.