

Lull[®]

Operators and Safety Manual

Model 644B

10709799

May 1997

ANSI



JLG[®]

Section	Page No.
INTRODUCTION	ii
SAFETY	1
INSTRUMENTS AND CONTROLS	8
BEFORE OPERATING THE MACHINE	19
GENERAL OPERATING PROCEDURES	21
FLUID AND LUBRICANT SPECIFICATIONS	26
SERVICE/LUBRICATION SCHEDULE	28
SAMPLE LOAD CHART	32

SAFETY ALERT SYMBOL



This Safety Alert Symbol means:

ATTENTION! BECOME ALERT! YOUR SAFETY IS INVOLVED!

When you see this symbol, be alert to the possibility of personal injury or death. Follow the instructions in the safety message.

Three Reasons Why Safety is Important to You:

- 1. Accidents disable and kill.**
- 2. Accidents cost.**
- 3. Accidents can be avoided.**

W1027

INTRODUCTION

INTRODUCTION

You are about to operate one of the finest forklifts available on the market today. To ensure that your forklift will provide years of safe dependable service, only trained and authorized persons should operate and service the forklift. It is the responsibility of the operator to read, fully understand and follow all operational and safety related instructions contained in this manual. Do not operate the forklift until you have read and fully understand these instructions. Remember, always use good safety practices to protect yourself and those around you.

REGISTRATION

The Warranty Registration card must be filled out by the dealer and returned to the "Warranty Administrator" indicating the date the machine went into service. The Pre-Delivery Inspection Form must be signed by the customer when the machine is delivered.

IMPORTANT

This operators manual must remain with the machine at all times!

LULL® has made every effort to provide information as complete and accurate as possible for its forklifts. However, because of owner requirements, equipment and control variations may exist between machines. In addition, due to **LULL**® policy of continually striving to improve its products, occasional discrepancies may exist between machines and the descriptions and information contained herein.

LULL® reserves the right to make changes and improvements to its products at any time without public notice or obligation. **LULL**® also reserves the right to discontinue manufacturing any product at its discretion at any time.

Copyright © 1997 **LULL INTERNATIONAL, INC.**, St. Paul, MN. All rights reserved. This document may not be duplicated, including electronic digitization, in whole or in part without the expressed written consent of **LULL INTERNATIONAL, INC.**



CAUTION, WARNING, & DANGER: WHAT THEY MEAN

Hazards are identified by the “Safety Alert Symbol” and followed by a signal word: Caution, Warning, or Danger.

CAUTION

CAUTION means that a situation **COULD** be hazardous and **MAY** result in personal injury if not avoided.

CAUTION is also used to alert against unsafe practices.

WARNING

WARNING means that a situation **COULD** be hazardous and **MAY** result in serious injury or death if not avoided.

DANGER

DANGER means that a situation **IS HAZARDOUS AND WILL** result in serious injury or death if not avoided.

SAFETY STANDARD

The ASME/ANSI B56.6 safety standard for rough terrain forklift trucks defines safety requirements relating to the design, operation, and maintenance of these vehicles. For a copy of this standard write to:

The American Society of Mechanical Engineers
United Engineering Center
345 East 47th Street
New York, NY 10017

DECALS

The decals on the machine provide instructions for safe and correct operation.

Never make modifications affecting safe operation or capacity without the expressed written approval of **LULL®**.

When **LULL®** approved modifications are made, the user is responsible for seeing that appropriate decals, load charts, and instructions are changed.

All plates and decals must be in place and legible at all times.

ROLL OVER PROTECTIVE STRUCTURE (ROPS) & FALLING OBJECT PROTECTIVE STRUCTURE (FOPS)

This machine is equipped with a Roll-Over Protective Structure (ROPS) to guard the operator if the machine tips over. The Falling Object Protective Structure (FOPS) is built into the ROPS. The FOPS protects the operator from falling objects.

Despite the protection of the ROPS/FOPS, it cannot protect the operator from every possible hazard. Do not consider the ROPS/FOPS a substitute for safe practices and good common sense.

Any modification to a ROPS/FOPS, such as welding or drilling holes in the structural members for mounting brackets, will affect the ROPS/FOPS capability to provide the required protection.

Any modification or repair without the specific written approval of **LULL INTERNATIONAL, INC.** will void the ROPS/FOPS certification. Contact your authorized **LULL INTERNATIONAL, INC.** dealer before making any modifications or repairs. Failure to do so may void the ROPS/FOPS certification.

SAFETY

REFUELING SAFETY

- Never smoke near the machine during refueling.
- Do not permit anyone to be on the machine during refueling.
- Spilled fuel must be completely absorbed or evaporated before starting the engine.
- Make sure the fuel cap is in place before starting the engine.
- Never use an open flame when checking the fuel level in the tank.
- Never fill the fuel tank with the engine running. Make sure you have adequate ventilation during fueling.

OPERATOR QUALIFICATIONS AND TRAINING

- Only trained and authorized persons should operate and service the machine. To be qualified, you must understand the written instructions supplied by the manufacturer, have training (including actual operation of this machine) and know the safety rules and regulations for the jobsite. A self-training course available from the Mason Contractors Association of America is highly recommended.
- LULL**® has produced an operational safety video that is available on VHS tape. This video shows safe operating and maintenance practices for your forklift. Contact your **LULL**® authorized dealer to obtain a copy of this video.
- Do not operate the machine until you fully understand the function of all controls, indicators and instruments.

PERSONAL SAFETY

Wear all the protective clothing and personal safety devices issued to you or called for by job conditions.

You may need...

- A hard hat
- Safety shoes
- Safety glasses, goggles, or face shield
- Heavy gloves
- Hearing protection
- Reflective clothing
- Wet weather gear
- Respirator or filter mask

- Avoid entanglement hazards. Do not wear clothing or jewelry that could catch on machinery. Keep your hands, hair, feet and clothing away from moving parts. Always keep your hands and feet inside the cab.
- Know the pinch points and rotating parts on the machine.
- Always know where to get assistance in case of an emergency. Know how to use a first aid kit and fire extinguisher.

MACHINE STABILITY

Your **LULL**® rough terrain forklift is proven to be stable when properly operated. However, improper operation, faulty maintenance, unauthorized modifications, or poor housekeeping may cause instability.

Some Conditions that Affect Stability:

- Ground and surface conditions.
- Surface grade.
- Weight and configuration of the attachment.
- Improper tire inflation and ballast content.
- Operator judgement.
- Excessive tilting of the fork carriage or other attachments with an elevated load can cause machine instability. The amount of allowable tilt is governed by conditions such as boom elevation, weight of load, and terrain.

STARTING SAFETY

Before Starting the Engine...

Important: Warn all others in the area that you are going to start the forklift.

1. Check underneath and around the machine and make sure all personnel are clear.
2. Be properly seated.
3. Set the park brake.
4. Make sure shift selector is locked in the NEUTRAL position.
5. Apply the brakes.

OPERATION SAFETY

- Safe operation is the responsibility of the operator.
- Improper use of the machine can lead to dangerous situations for yourself, those around you, the machine and the work area. You must have safe working habits and be aware of hazardous working conditions.
- Thoroughly read and understand this entire manual. Follow all safety rules and practices explained in this manual.
- The machine must be checked every day or at the start of each shift. See "Check The Equipment" on page 19.
- To meet the requirements of different operating conditions, **LULL**® offers optional lighting packages for your machine. Do not operate the machine if it is not equipped with lights when conditions require them. If your machine is not equipped with the proper lights, contact your authorized **LULL**® dealer for available lighting packages.
- If operating in an enclosed or partially enclosed environment, make sure there is enough ventilation. Engine exhaust fumes can be deadly to you and those around you if precautions are not taken. Questions about the air quality in the working environment and sampling methods should be directed to a qualified person.

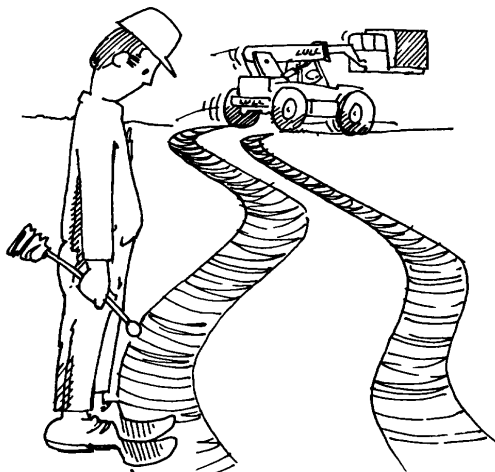

Never operate the machine controls while you are outside the cab. You must be properly seated in the cab before operating any controls.

Before Leaving the Cab...

- Bring the machine to a full stop.
- Apply the park brake.
- Lower the boom.

Before Leaving the Machine Unattended...

- Stop the engine.
- Block the wheels if parked on an incline.
- Lower the boom.

The machine is considered "attended" when the operator is less than 25 feet from the machine and it remains in the operator's view.

The machine is considered "unattended" when the operator is 25 feet or more from the machine and the machine is in the operator's view, or whenever the machine is not in the operator's view.

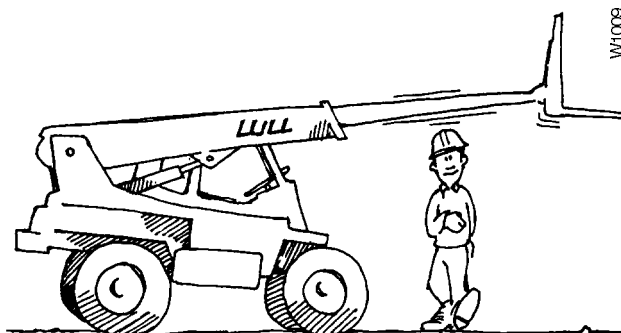

Never stand or walk under a raised boom. Do not allow others to do so.

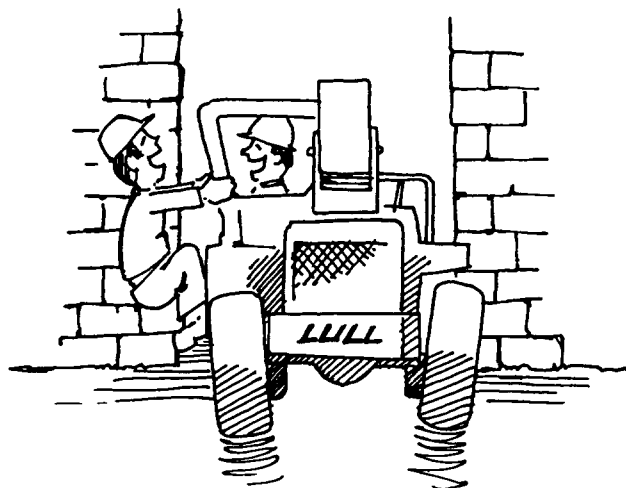

Never allow passengers on the machine.

W11009

W11008

W11007

SAFETY

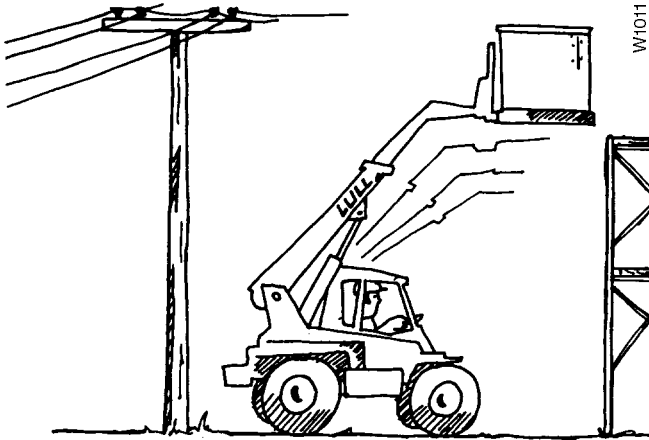

W1011

Always check clearances under power lines and overhead structures before driving under them.

- ❑ DO NOT operate the machine near energized power lines. Always contact the electrical power company when operating near power lines. The lines should be moved, insulated, disconnected, or de-energized and grounded before operating in the area. Keep all parts of the machine at least 50 feet away from power lines. Contacting electrical power lines WILL result in serious personal injury or death!



⚠ DANGER
KEEP ALL PARTS OF MACHINE AT LEAST 50 FEET FROM POWER LINES. CONTACTING ENERGIZED POWER LINES WILL CAUSE SERIOUS PERSONAL INJURY OR DEATH!

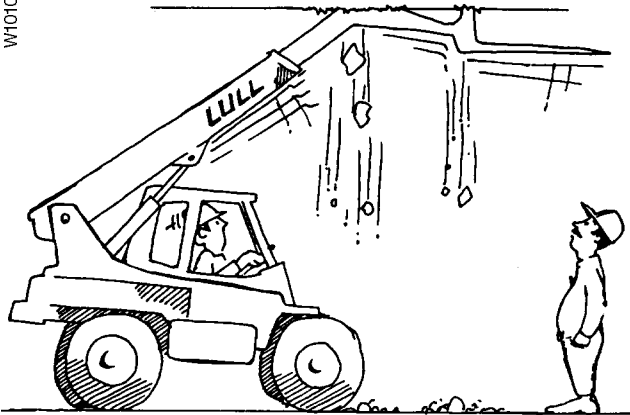

W1010

Always check for enough overhead clearance for the boom.

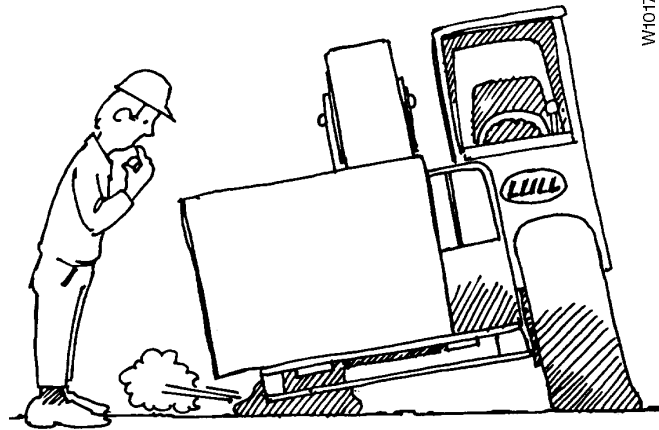

W1017

Ensure that correct tire pressure and tire ballast levels are maintained.

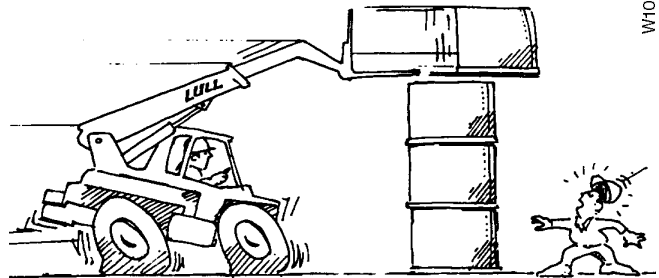

W1014

Never attempt to discharge a load by stopping the forklift suddenly.

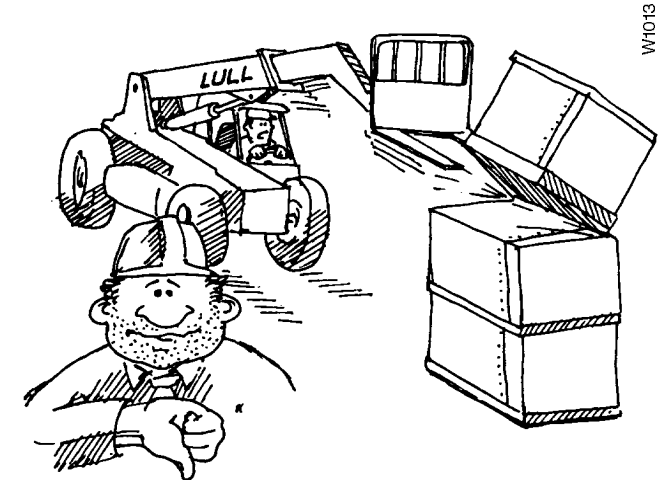

W1013

Never lift a load using one fork.

W1016

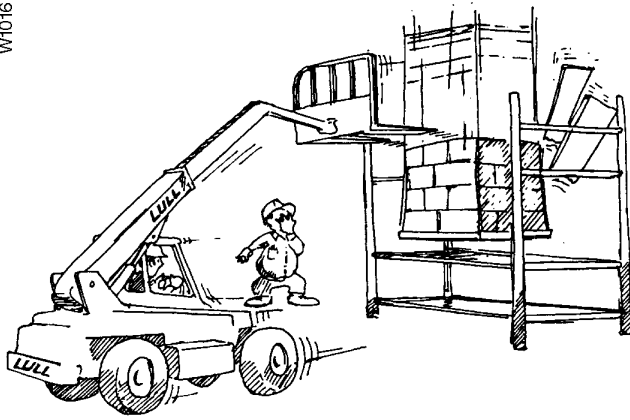

Never place loads that exceed scaffold capacity or subject scaffold to unnecessary "shock" loads.

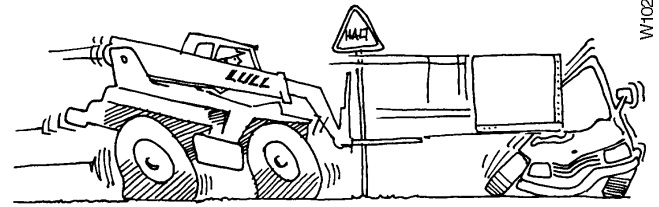

W1021

Drive carefully and avoid sudden stops and changes of direction.

W1020

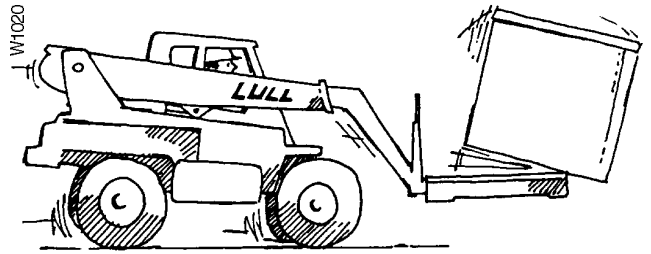

Ensure that the load is stable and secure. Check to see that there are no loose articles that may fall off the fork.

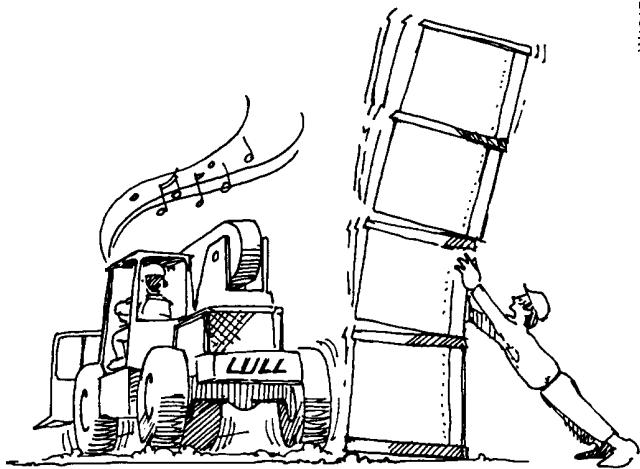

W1015

Never stack a load on uneven ground.

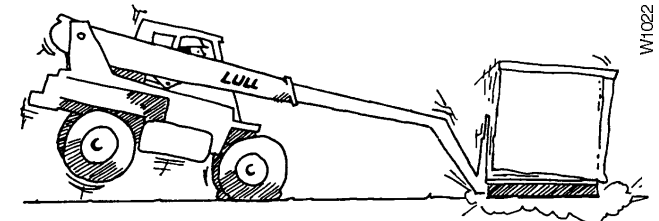

W1022

Always check the load charts before picking up a load.

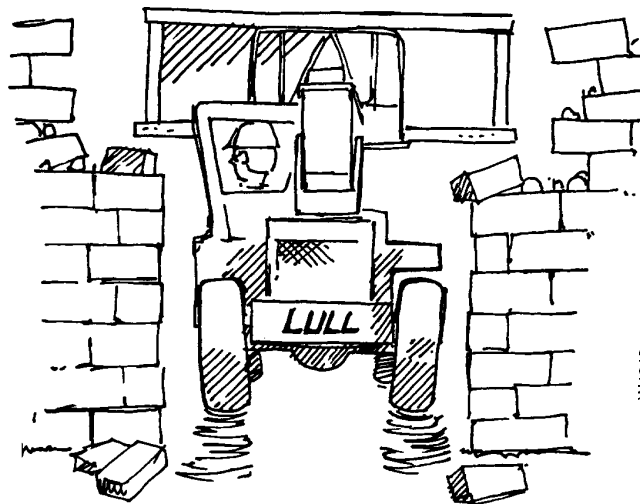

W1019

Always be aware of load width.

W1023

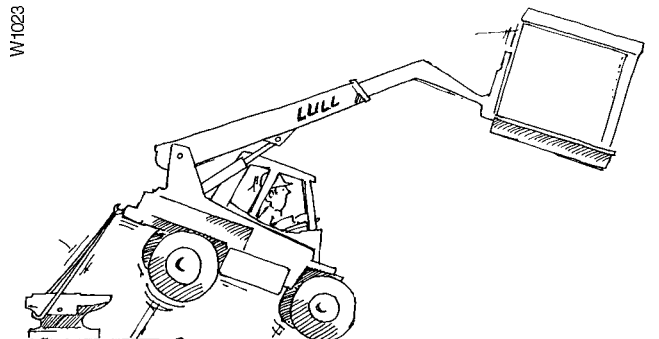

Never add unauthorized counterweights.

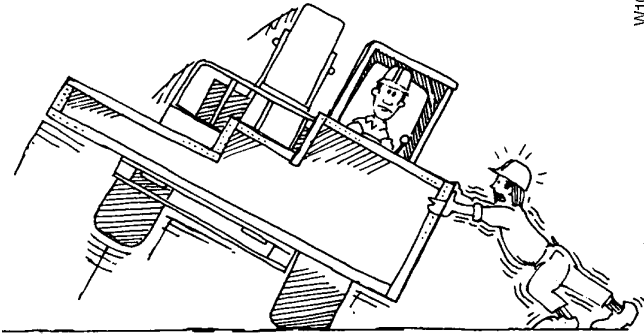

Always pick up the load at its center of gravity.

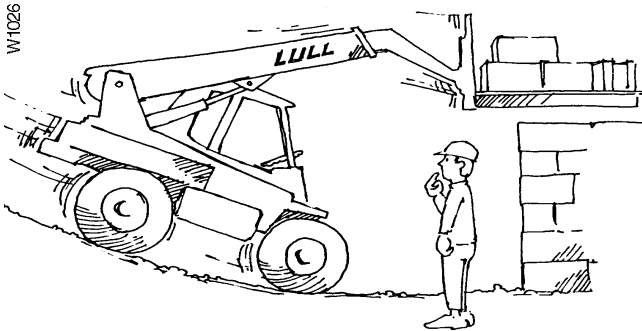

Avoid parking on slopes. If it is necessary to park on a slope, set the parking brake and block the wheels.

When Traveling On Inclines...

- Tilt the attachment back and raised only enough to clear the ground.
- Avoid turning. If it cannot be avoided, turn slowly and with extreme caution.
- Travel straight up and down grades.
- When loaded and traveling up or down grades, travel only with the load uphill.
- When unloaded, travel only with the forks or attachment downhill.
- Proceed slowly and with extreme caution.
- Do not travel across excessively steep slopes.

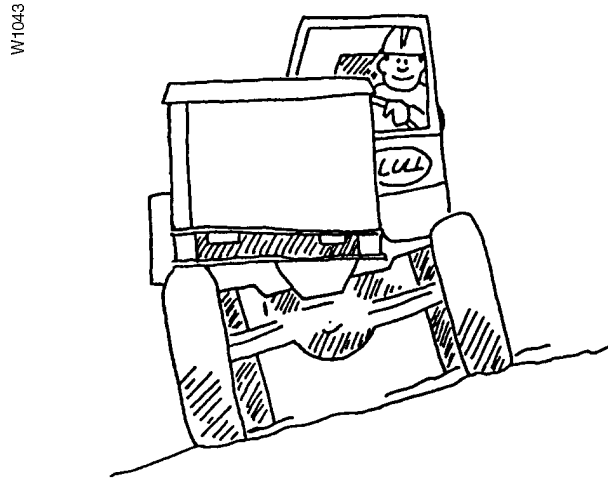

The machine can be levelled side to-side a total of 12.5° in each direction (22% grade). Any slope or grade that exceeds this is considered excessively steep.

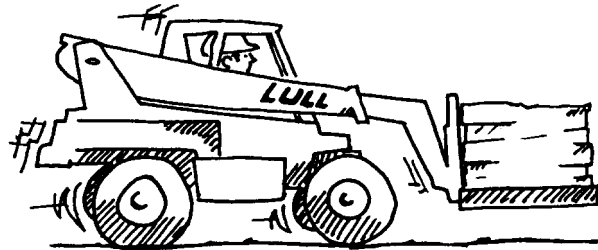

Drive slow and carry the load as low as possible.

When Traveling on Roadways...

- Make sure the machine is equipped with all necessary lights and safety signs required for traveling on roadways.
- Observe all traffic laws and speed limits.
- Keep to the correct side of the roadway.
- Keep a safe distance from other vehicles.
- Maintain control of the machine at all times.
- Yield the right-of-way to pedestrians and emergency vehicles.
- Do not pass another vehicle at intersections, blind spots, or other dangerous locations.
- Avoid running over loose objects and debris.

Additional Safety Instructions:

- Maneuver the machine carefully. Do not cause the load to shift or the machine to tip.
- Slow down for wet and slippery surfaces and changes in terrain.
- Turn the steering wheel smoothly and slow down when turning.
- Do not make sharp turns at high speeds.
- Take special care when traveling without a load. The machine is more susceptible to tipping over on its side.
- Do not continue to operate the machine if an unsafe condition is found. Stop the machine and report the condition to the designated authority.
- Never make repairs or adjustments unless you are authorized to do so.
- Always keep your hands and feet inside the cab, especially when in or around structures.
- Never reach into the boom or attachments.
- Understand the limitations of the machine and drive safely.
- Watch for pedestrians, especially when backing up or turning and where pedestrians may step into the path of the machine.
- The machine may add to the overall sound level of the work area. Give consideration to the sound exposure of those working around you.
- If a fuel leak is found, do not operate the machine until the problem is fixed.
- When approaching areas where vision is obstructed, always slow down and sound the horn.
- Report all accidents involving personnel, building structures, and equipment to your supervisor or as directed.
- Use caution when operating on ramps, platforms, trenches, and other similar surfaces.
- Keep a clear view of the terrain and where the machine is heading. Watch out for other vehicles, people, and structures.
- If the load blocks your forward view, then carefully travel in reverse and use a signalman to guide you if necessary.
- Do not block access to fire lanes or fire equipment.

INSTRUMENTS AND CONTROLS

GAUGES

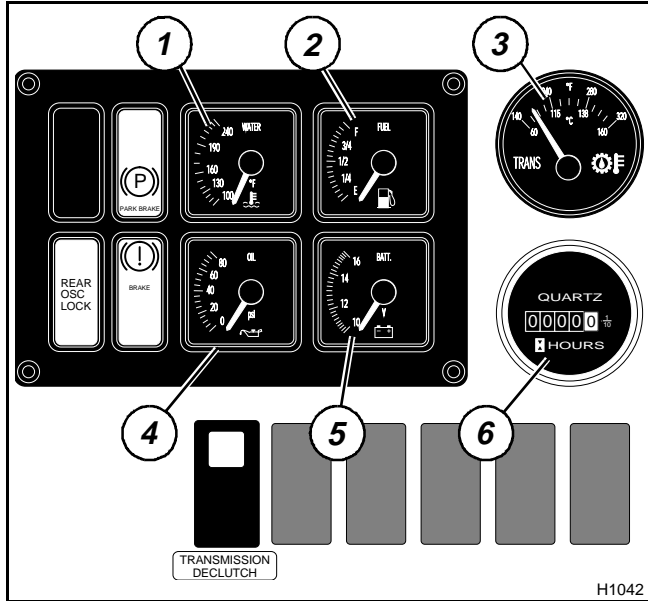

Gauges

Note: Gauges and indicator lights operate only when the ignition switch is in the ON position.

- (1) **Engine Water Temperature**—Registers from 100 to 240 °F. Normal operating temperature is 180 to 185 °F.
- (2) **Fuel Level**—Shows fuel level in fuel tank.
- (3) **Transmission Oil Temperature**—Registers from 140 to 320 °F with Celsius equivalents. If the temperature rises above 230 °F (110 °C) stop the vehicle immediately, shift to neutral and run the engine at half throttle. The temperature should drop quickly. If the temperature does not drop, shut off engine and investigate.
- (4) **Engine Oil Pressure**—Shows operating engine oil pressure. Gauge registers from 0 to 80 PSI. Normal operating pressure is 55 to 60 PSI.
- (5) **Voltmeter**—Indicates system voltage. Gauge registers from 10 to 16 volts. Normal operating voltage range is 14.5 to 15 volts. With ignition in ON position and engine off, battery voltage is indicated. This should normally be 12.6 volts.
- (6) **Hourmeter**—Registers total hours of machine operation.

INDICATOR LIGHTS

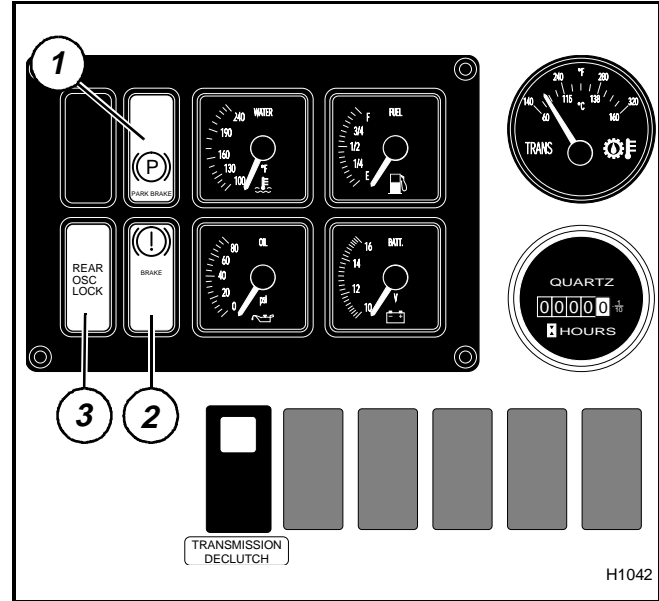

Indicator Lights

- (1) **Park Brake**—Red lamp lights to show when park brake is applied and goes out when park brake is released.
- (2) **Low Brake Pressure**—Red lamp lights and buzzer sounds when service brake hydraulic system pressure drops below the safe operating level. Under normal conditions, the light and buzzer will go out quickly after engine start. If the light or buzzer does not go out or comes on during machine operation, shut off engine immediately, investigate, and repair before operating. Do not operate machine when low brake pressure light or buzzer is on.
- (3) **Rear Oscillation Lock**—The rear oscillation lock light will come on when the boom angle is above 40°.

IGNITION SWITCH

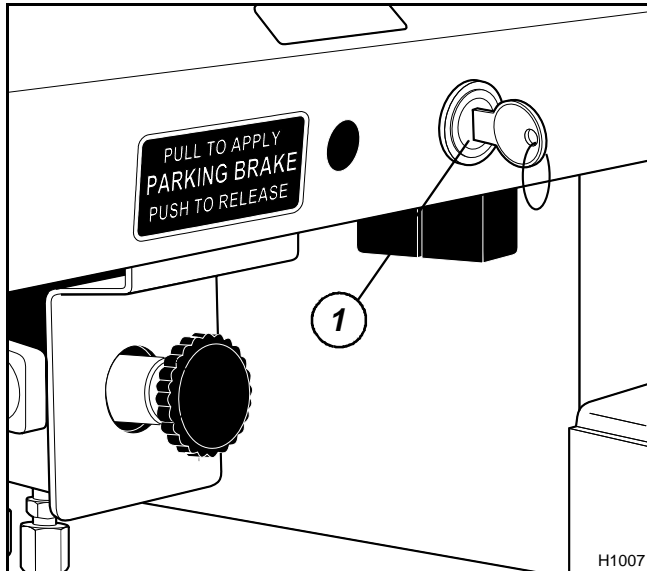

Ignition Switch Location

The ignition switch (1) is located on the dash, near the right side.

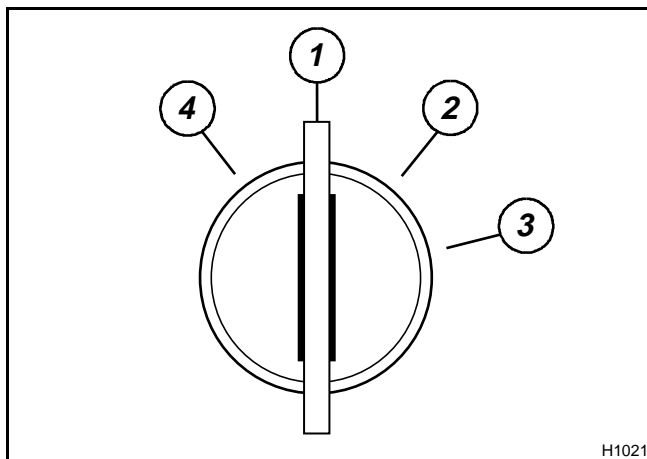

Ignition Switch Positions

The ignition switch has four positions:

- (1) **OFF:** The key may be removed or inserted only at this position. The engine and all electrical circuits except the horn circuit are shut down at this position.
- (2) **ON:** All electrical circuits except the engine starter circuit are operational.
- (3) **START:** Activates the engine starter. When the key is released the switch will return to the ON position and remain there.
- (4) This position is reserved for future use and currently has no function.

Note: The starter will not engage unless the shift selector is placed in the NEUTRAL position.

THROTTLE

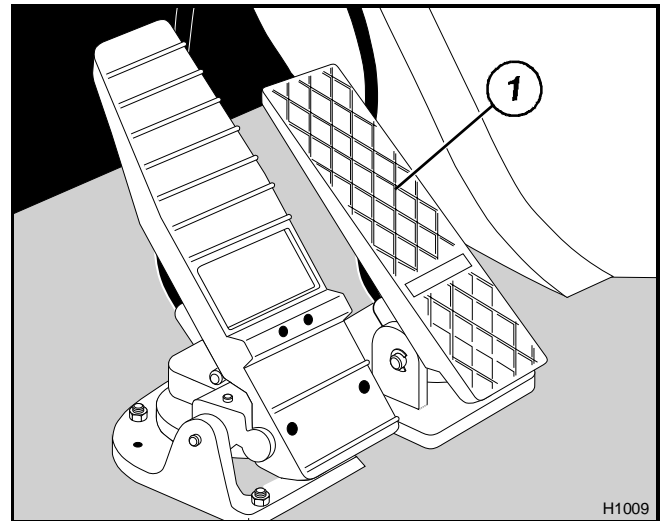

Engine Throttle Pedal

Push throttle pedal (1) down to increase engine speed.

BRAKE PEDAL

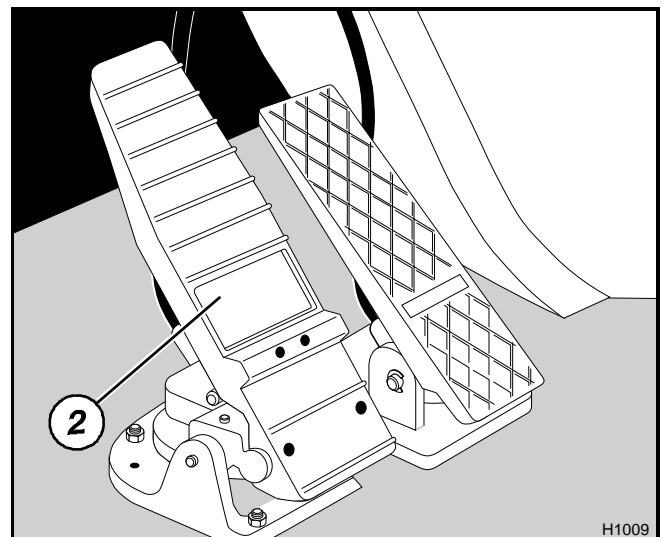

Service Brake Pedal

Push brake pedal (2) down to slow or stop machine.

INSTRUMENTS AND CONTROLS

PARK BRAKE CONTROL

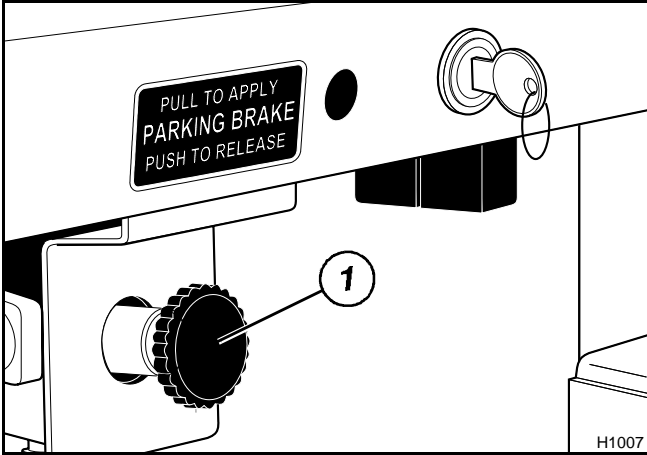

Park Brake Control

Pull knob (1) out (toward you) to engage the park brake.

Important: Always stop the machine with service brakes before engaging park brake. Do not use the park brake to slow or stop the machine **EXCEPT** in an emergency.

Note: When park brake is engaged, transmission will default to NEUTRAL, regardless of shift selector position.

SHIFT SELECTOR

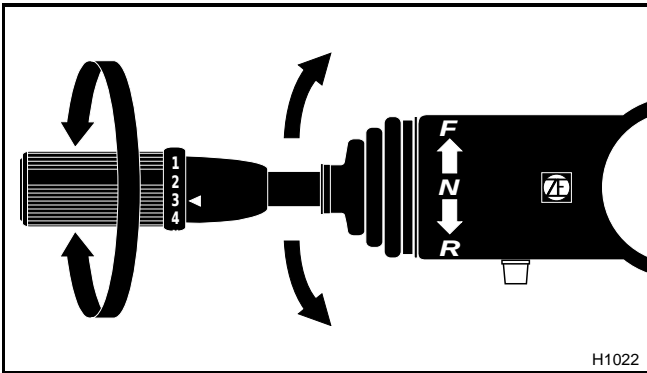

Shift Selector

The shift selector is located on the steering wheel column. It controls machine travel direction and transmission speed range.

Direction Control

Machine travel direction is controlled by moving the shift lever to one of three positions:

FORWARD (F): Move the lever fully forward to select forward machine movement.

NEUTRAL (N): Move the lever to the center position to disengage the transmission. The engine may be started only when the transmission is in NEUTRAL.

REVERSE (R): Move the lever fully rearward to select reverse machine movement.

Speed Range Selection

The transmission has three speed ranges in forward or reverse. To select different transmission speed ranges, rotate the selector handle to the desired position. Speed ranges may be selected while the vehicle is moving in forward or reverse.

Note: The transmission requires 3 seconds immediately after engine start for self-diagnostics. Always wait at least 3 seconds after engine start before engaging transmission.

The following table shows the maximum travel speed for each position on the selector:

ZF 3WG-100 Speeds	
POSITION	SPEED
1	2.5 mph
2	5.9 mph
3	13.2 mph
4	(See Note)

Note: The Model 644B is not equipped with a fourth speed. If fourth is selected, the transmission will remain in third speed.

Neutral Lock

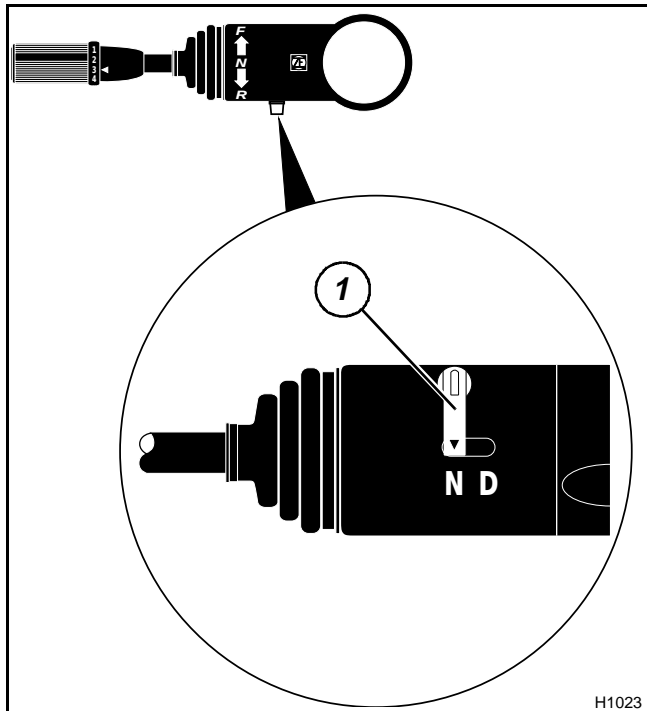

Neutral Lock

The shift selector is equipped with a neutral lock.

To lock the shift lever in the NEUTRAL position:

1. Place the lever in the NEUTRAL position
2. Move the neutral lock lever to the (N) NEUTRAL LOCK position.

To unlock, move the neutral lock lever to the (D) DRIVE position.

TRANSMISSION DECLUTCH SWITCH

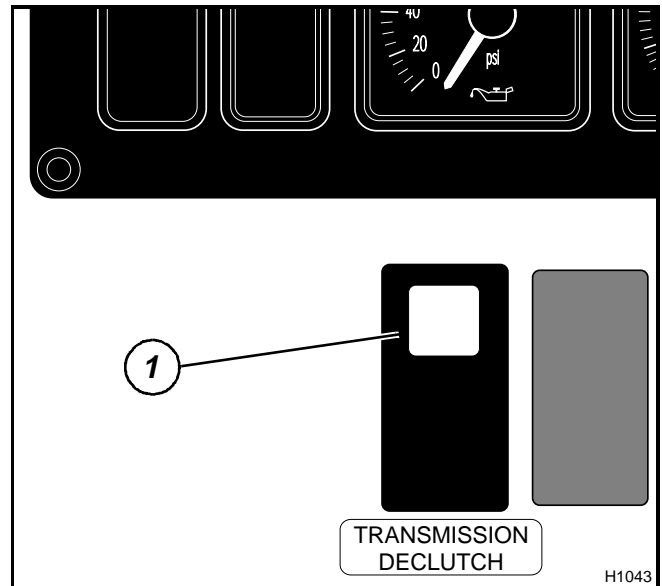

Transmission Declutch Switch

The transmission declutch switch **(1)** is an internally lighted rocker switch. Pressing the forward side of the switch activates the transmission declutch feature when the foot brake pedal is applied.

This feature eliminates the need to shift to NEUTRAL before operating the hydraulic system at high engine speeds. When the transmission is declutched, the drivetrain is disconnected and the hydraulic system has full engine power.

To use the Transmission Declutch Feature:

1. The transmission must be in first or second speed range, forward or reverse. The declutch feature will not operate when the transmission is in third speed range.
2. Press the forward side of the transmission declutch switch.
3. Press the service brake pedal or pull the park brake knob.
4. The switch will illuminate to show the transmission clutch has disengaged.

Press the rear side of the switch to deactivate the declutch feature.

INSTRUMENTS AND CONTROLS

STEER MODE SELECTOR

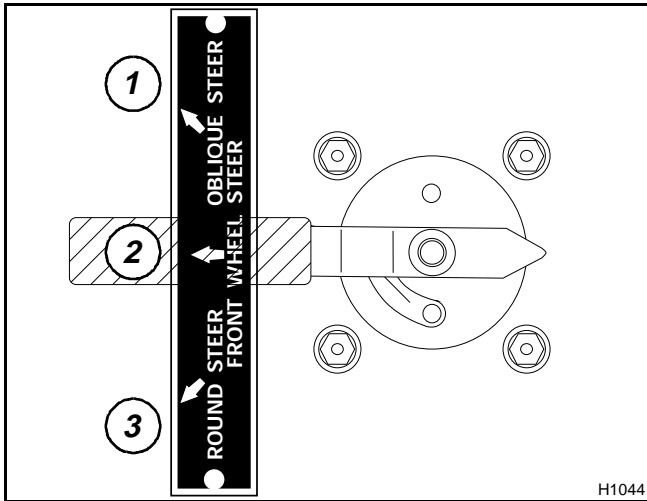

Steer Mode Selector

There are three steer modes available on your machine:

- (1) Oblique Steer (Crab Steer)
- (2) Front Wheel Steer (2-Wheel Steer)
- (3) Round Steer (4-Wheel Steer)

To select a steer mode, turn the steer mode selector so the handle aligns with a selection on the adjacent plate. You will feel the selector slip into a detent, or “catch,” when the desired mode is selected.

CAUTION

Never change steer modes while the machine is moving. The wheels can become misaligned and cause loss of control.

Always stop the machine completely and synchronize (straighten and align) the wheels before changing steer mode. See “Synchronizing (Straightening) the Wheels” on page 13.

Front Wheel Steer Mode

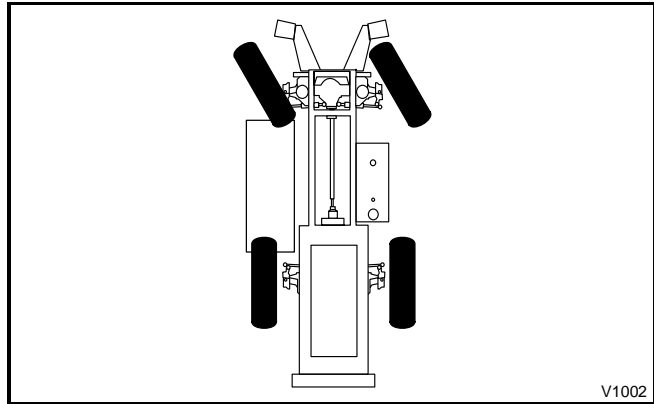

Front Wheel Steer Mode

Front Wheel Steer mode, also known as “2-Wheel Steer” mode, allows the operator to steer the machine in a conventional manner. The front wheels of the machine steer and the rear wheels remain in position.

Use this mode when traveling on flat surfaces at higher speeds. Front Wheel Steer mode should not be used in confined and congested areas.

Important: Synchronize (straighten and align) the wheels before engaging Front Wheel Steer mode.

Round Steer Mode

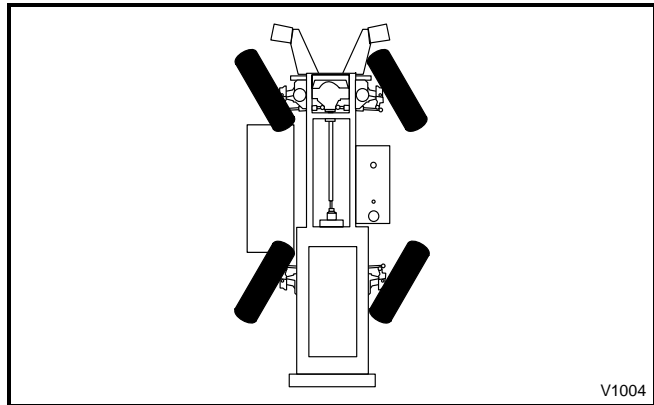

Round Steer Mode

Round Steer mode, also known as “4-Wheel Steer” mode, allows the front and rear wheels to steer in opposite directions.

Use Round Steer when tight turning is required. This mode is very useful on job sites.

Oblique Steer Mode

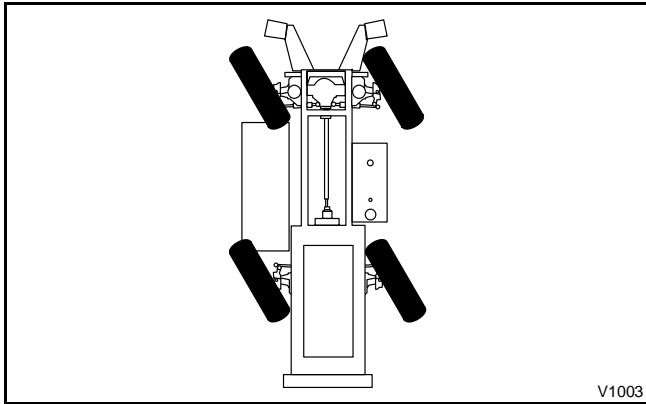

Oblique Steer Mode

Oblique Steer mode, also known as “Crab Steer” mode, enables steering of the front and rear wheels in the same direction.

It is generally used to angle the machine in tight areas. Oblique Steer mode moves the machine to the side while moving forward or reverse.

Synchronizing (Straightening) the Wheels

As different steer modes are selected, it is possible for the wheels to become misaligned. It is also possible for the wheels to drift out of alignment when traveling over long distances or rough terrain.

To synchronize (straighten and align) the wheels:

1. Select ROUND steer mode.

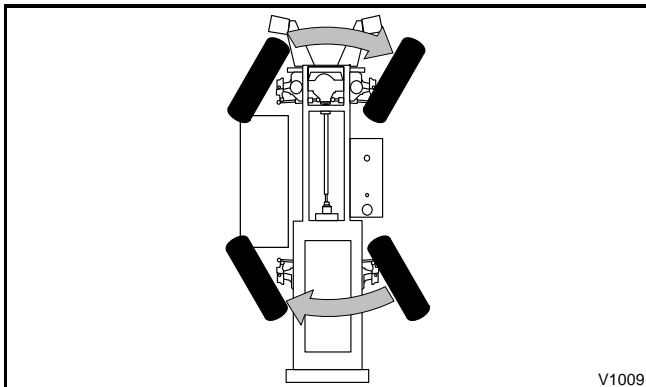

Step 2

2. Turn the steering wheel to the right until it reaches the stop.
3. Select FRONT WHEEL steer mode.

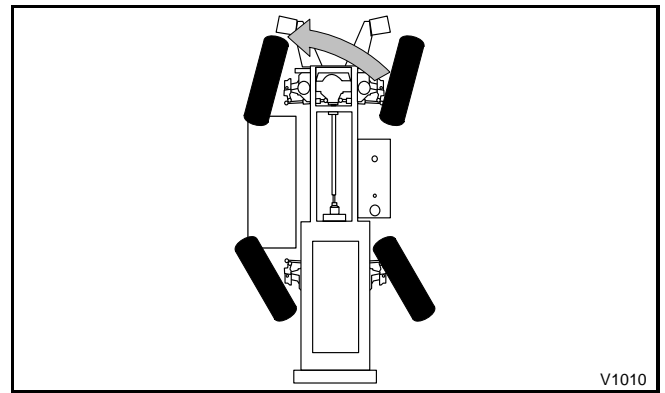

Step 4

4. Turn the steering wheel to the left about one turn.
5. Select ROUND steer mode.
6. Turn the steering wheel to the right until it reaches the stop. This makes sure the rear wheels are fully against right stop.
7. Select FRONT WHEEL steer mode.

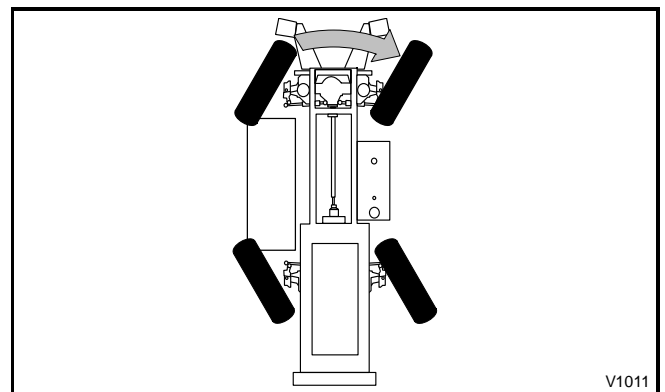

Step 8

8. Turn the steering wheel to the right until it reaches the stop.
9. Select ROUND steer mode.

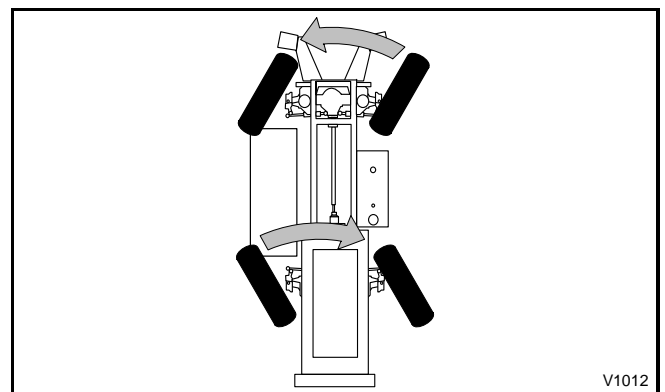

Step 10

10. Turn the steering wheel to the left until wheels are pointed straight ahead.

INSTRUMENTS AND CONTROLS

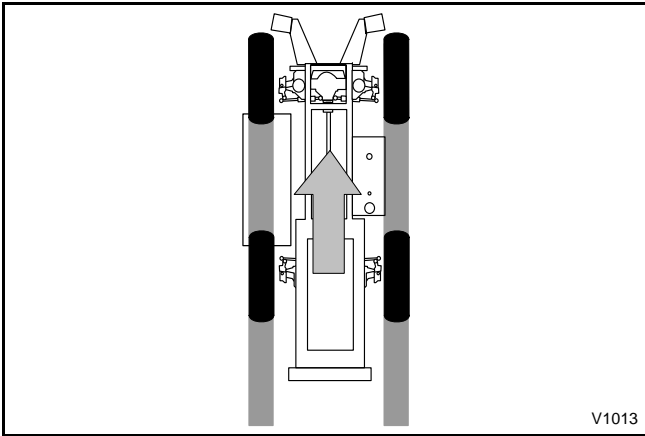

Step 11

11. Drive the machine forward a short distance to check wheel tracking.
12. Stop the machine and select the desired steer mode.

Note: The above procedure can also be done to the left side.

STANDARD JOYSTICK CONTROLS

General Description — Joysticks

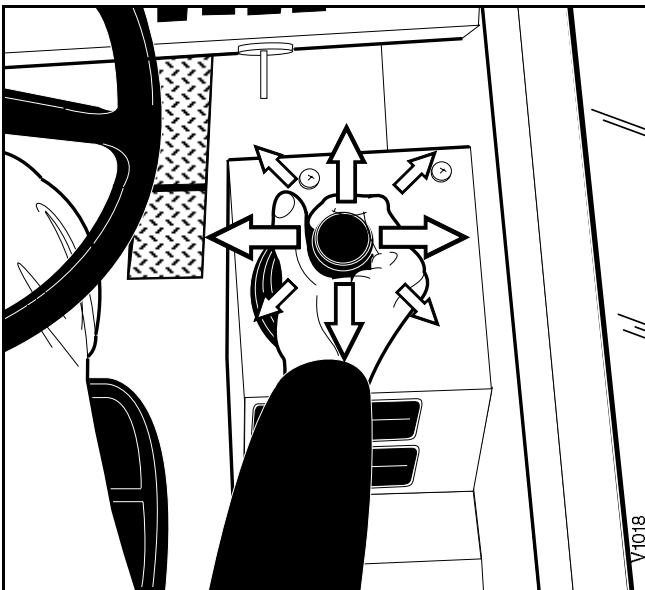

Joystick

The joysticks control hydraulic flow to the associated cylinders.

Control is proportional: The more joystick movement, the greater the action. The speed of cylinder action is also affected by engine/hydraulic pump speed. Action is quicker at higher engine speeds.

Joysticks can be moved in any direction and are not limited to front/back, left/right movement. Moving a joystick in a diagonal direction will cause a combination of actions.

Front Joystick

The front joystick controls transfer carriage extension and attachment tilt.

An auxiliary function is also available by pressing the button on top of the handle. See "Auxiliary Joystick Controls" on page 16 for further information.

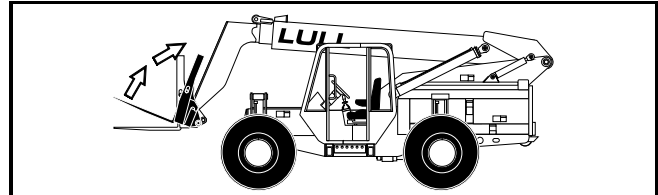

Tilting Attachment Up

Pulling back on the front joystick tilts the attachment upwards.

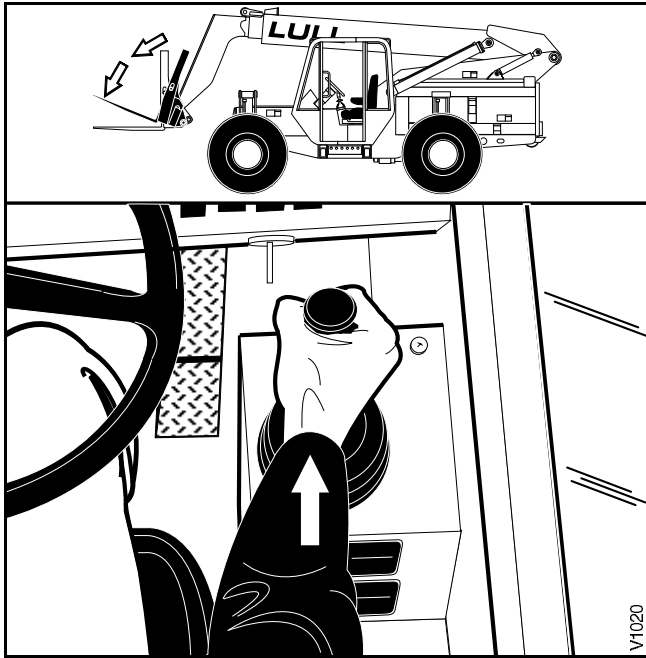

Tilting Attachment Down

Pushing forward on the front joystick tilts the attachment downwards.

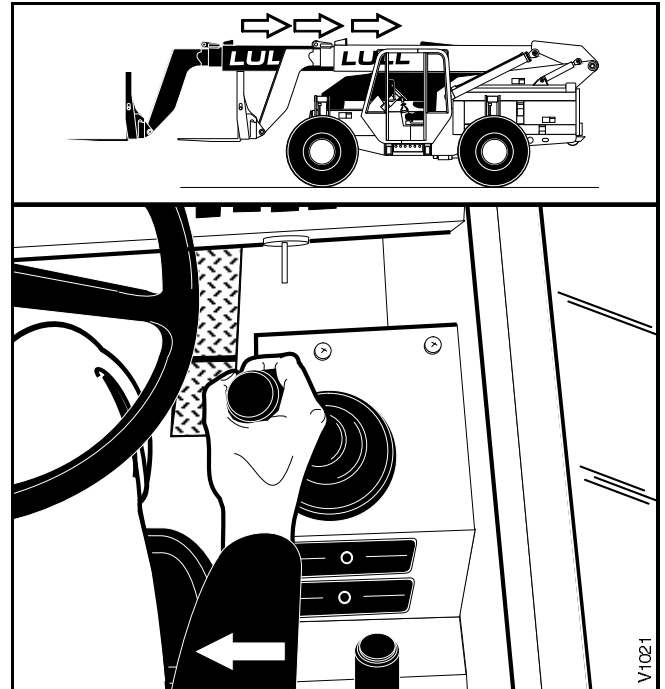

Retracting the Transfer Carriage

Moving the front joystick to the left retracts the transfer carriage.

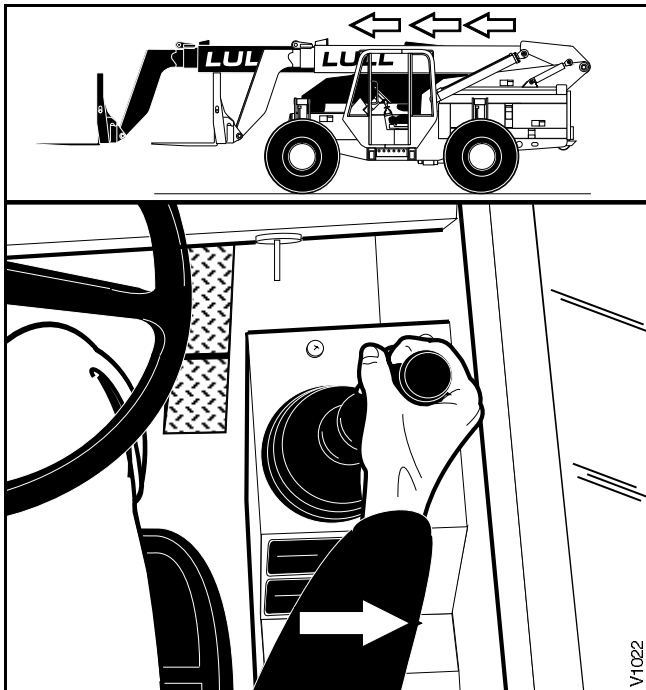

Extending the Transfer Carriage

Moving the front joystick to the right extends the transfer carriage

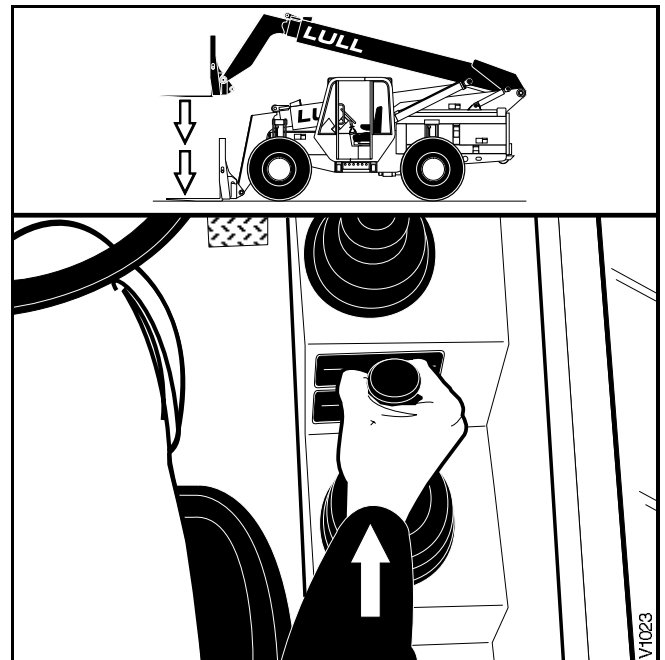

Lowering the Boom

Moving the rear joystick forward lowers the boom.

INSTRUMENTS AND CONTROLS

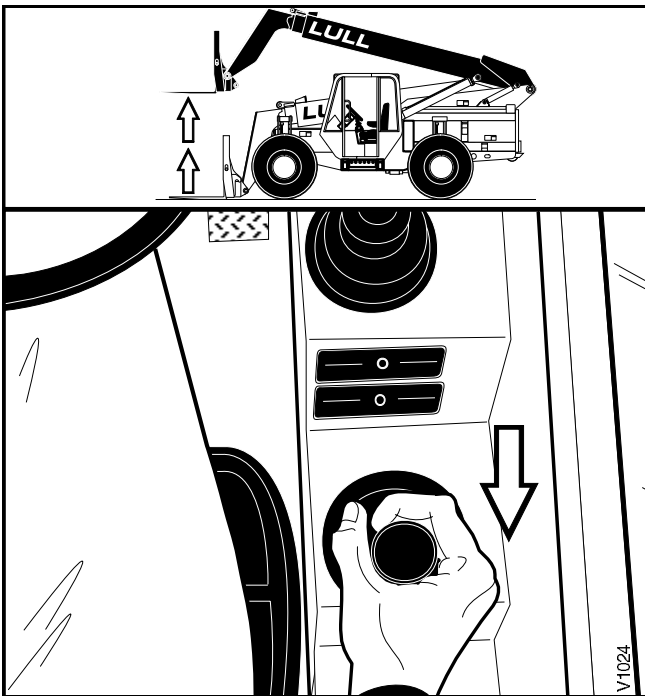

Raising the Boom

Pulling back on the rear joystick raises the boom.

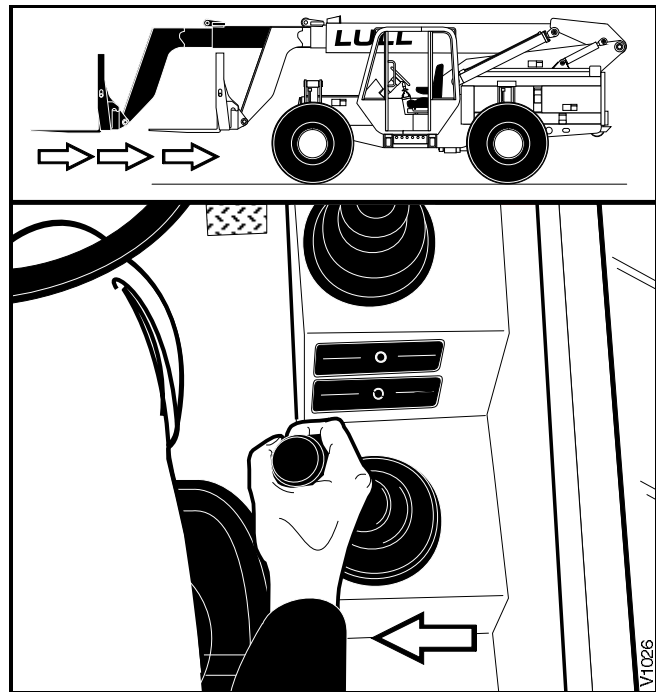

Retracting the Boom

Moving the rear joystick to the left retracts the boom.

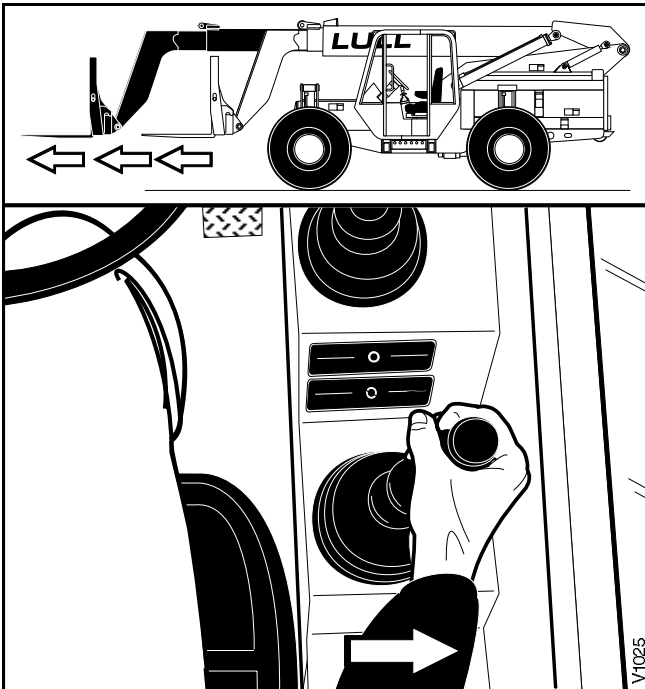

Extending the Boom

Moving the rear joystick to the right extends the boom.

AUXILIARY JOYSTICK CONTROLS

General Description — Auxiliary Joystick Controls



Auxiliary Joystick Control

A switch is located on the top of the front joystick, under a protective rubber cap. Pressing this switch down with your thumb activates the auxiliary function.

Hold the switch down while moving the joystick left and right. Functions for specific attachments are shown below.

Note: Releasing the switch while moving the joystick left or right changes the function of the joystick back to transfer carriage control.

Tilting Carriage Control

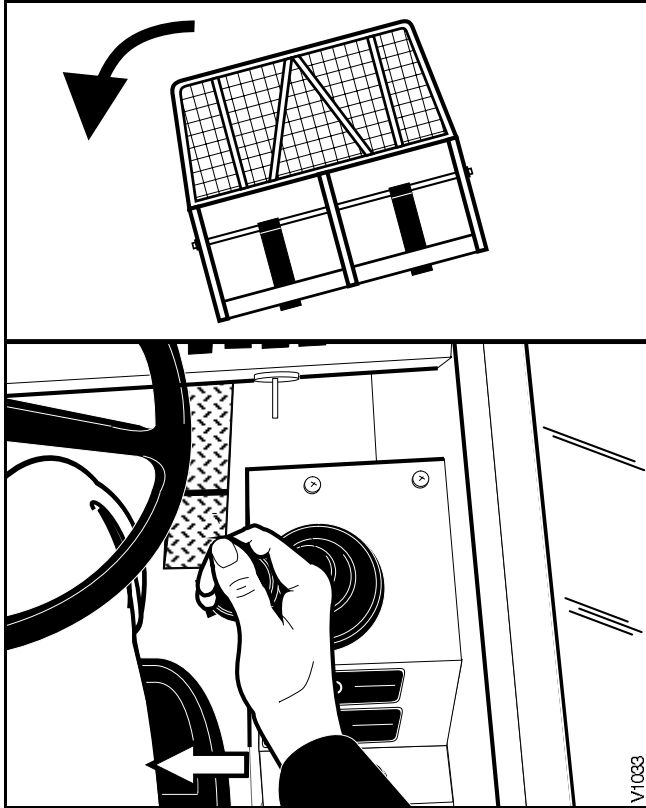

Rotating Tilt Carriage to Left

Holding the button down and moving the front joystick to the left rotates an optional tilting carriage to the operator's left.

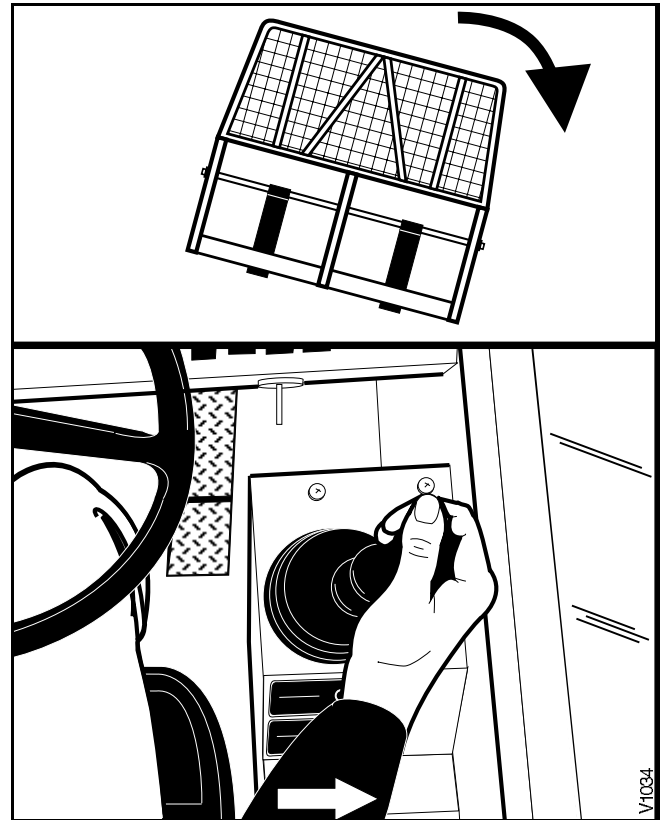

Rotating Tilt Carriage to Right

Holding the button down and moving the front joystick to the right rotates an optional tilting carriage to the operator's right.

BOOM ANGLE INDICATOR

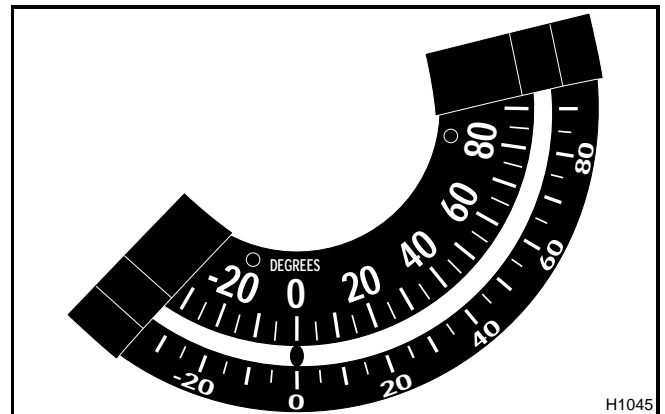

Boom Angle Indicator

The Boom Angle Indicator shows the angle of the boom relative to level ground. Use this indicator with the Boom Extension Indicator, Transfer Carriage Extension Indicator, and machine Load Chart to determine correct boom lifting capacities.

INSTRUMENTS AND CONTROLS

FRAME LEVEL INDICATOR

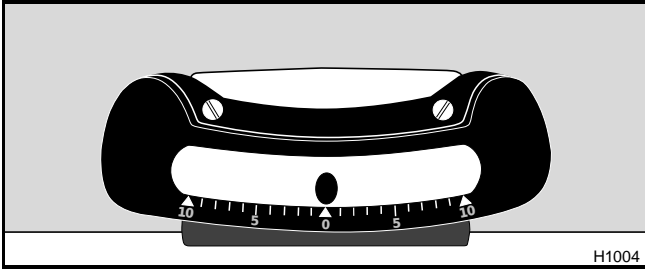

Frame Level Indicator

The Frame Level Indicator shows the lateral (side-to-side) angle of the frame relative to level ground. Indicator range is from 0° to 10° left or right, in increments of one degree. When the ball is centered (0°), the machine is laterally level. The frame tilt feature may be used to correct machine angles up to 12.5° to the left or right. See “Frame Tilt Control” below.

The control lever (1) is equipped with a safety lock to prevent unintentional operation. Lift the lock ring (2) to unlock the lever and allow it to be moved left or right. Return the control lever to center position and release lock ring to secure lever.

The lever can be moved either left or right, tilting the frame accordingly. To level the frame, move the lever in the direction you want the ball in the frame level indicator to move.

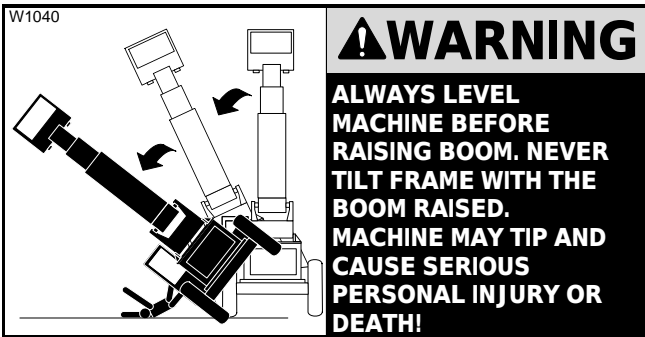

FRAME TILT CONTROL

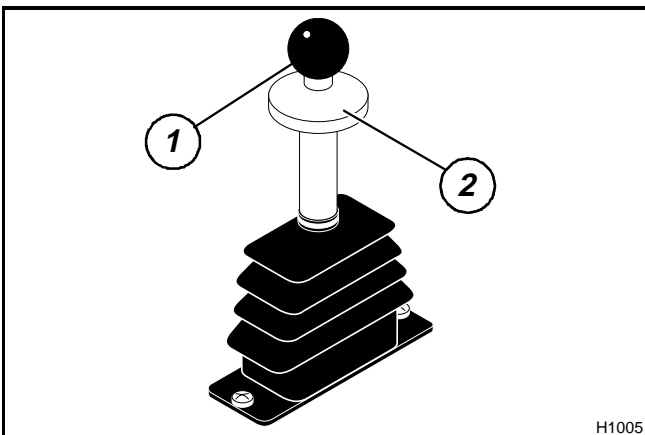

Frame Tilt Control

The frame tilt control is used to level the machine laterally (side-to-side) up to 12.5°, left or right. The lateral angle of the machine, relative to level ground, is shown on the frame level indicator (see “Frame Level Indicator” above). The control is functional only while the engine is running.

BEFORE OPERATING THE MACHINE

CHECK THE EQUIPMENT

Note: Before you begin your workday, take time to check (✓) your forklift and have all systems in good operational condition.

Check the following:

- ✓ Warning decals, special instructions and operators manuals. Make sure they are legible and stored in the proper location. **NEVER** operate without a legible load chart.
- ✓ Engine oil level. Add oil as required.
- ✓ Radiator coolant level. Add coolant as required.
- ✓ Hydraulic fluid level. Add hydraulic fluid as required.
- ✓ Hydraulic hoses and hose connections for wear or leaks. Repair or replace any damaged hoses or connections.
- ✓ Transmission oil cooler and engine radiator for dirty fins.
- ✓ Back-up alarm and horn.
- ✓ Forks for welded repairs, cracks, wear and misalignment.

WARNING

Never repair forks by welding. Never use forks with welded repairs. Forks may break and falling load or forks may cause serious injury or death.

- ✓ Tires for cuts, bulges, correct tire pressure and proper ballast content.
- ✓ All wheel lugs.
- ✓ Service and park brakes for proper operation.
- ✓ All instruments, gauges and indicator lights.
- ✓ The steering, left and right.
- ✓ All control levers for proper operation.
- ✓ Keep engine and radiator clean and free of dirt and flammable material.
- ✓ The condition and operation of the seat belt and its mounts.
- ✓ Steps, pedals, and non-skid surfaces. Make sure they are clean and free of dirt, grease, oil, snow and ice.
- ✓ Placement and operation of doors, guards and covers.
- ✓ Cleanliness and operation of mirrors, window wipers and work lights.

Note: If there is any indication that faulty equipment exists, shutdown safely, inform the proper authority and **DO NOT** operate the forklift until the problem has been fixed.

- ✓ Remove or put away tools, lunch buckets, chains, hooks or any other loose objects that could interfere with operation.

KNOW THE WORK AREA

Learn as much as possible about the work area before operation. Walk around the worksite and inspect the terrain that you will be travelling on.

Make a note of surfaces to be avoided, including...

- Holes & Drop-offs.
- Obstacles.
- Soft mud & standing water.
- Oil spills & slippery surfaces.

Note: If any of the above conditions exist in the work area, correct the condition before operating. If the condition cannot be corrected, avoid operation in the problem area.

When operating on docks, ramps or floors, check for weak spots. Clear away trash and debris. Pick up anything that could puncture a tire. When required, check the forklift's maximum fully loaded ground pressure weight if operating on a hollow floor system.

Watch for conditions that could cause...

- Loss of control.
- A collision.
- Tipover.

Check overhead clearances. Know the size of doorways and canopies. Know exactly how much clearance you have under power lines and telephone lines.

All local, state/provincial and federal regulations must be met before approaching power lines, overhead or underground cables or other power sources with any part of your forklift. Do not operate the machine near energized power lines. Always contact the electrical power company when operating near power lines. The lines should be moved, insulated, disconnected, or de-energized and grounded before operating in the area. Keep all parts of the machine at least 50 feet away from power lines.



BEFORE OPERATING THE MACHINE

PLAN YOUR WORK

Before you operate, know how and where you will travel, turn and pickup, lift and place loads.

Choose a smooth level route to prevent possible tipover or loss of load.

If possible, avoid crossing...

- Ruts.
- Ditches.
- Curbs.
- Exposed railroad tracks.

Note: *When these conditions cannot be avoided, keep the load as low as possible and travel very slowly and with extreme caution.*

Know where there are any blind corner conditions on the worksite. Before turning a blind corner, stop, sound your horn, and proceed slowly.

Always maintain safe distances between your forklift and other equipment that may be on the worksite.

Know the weights of all loads you may be expected to transport before attempting to lift them. Avoid loads of loose material if possible. Check that loads are properly banded or strapped together.

If you will be placing loads at high elevations, remember your depth perception is decreased because of distance. Use a signal person near the point where the load is to be landed.

Insure that adequate clearance is provided between both rear tail swing and front fork swing of the forklift to avoid injury to personnel or damage to nearby equipment.

Know where you will be expected to park your forklift at the end of the work day, preferably in a level area out of traffic. If the area is on a slope or incline, position the forklift at right angles to the slope, set the parking brake, lower the boom to the ground, and block the wheels.

Remember...

- Be alert - know that conditions can change.
- Use common sense - show that you are a responsible operator.
- Be a defensive operator - prevent accidents before they happen.

SAFE MACHINE OPERATION

For safe operation of this rough terrain forklift you must be a qualified and authorized operator. To be qualified, you must understand the written instructions supplied by the manufacturer, have training (including actual operation of this machine) and know the safety rules and regulations for the jobsite.

An operator must not use drugs or alcohol which can affect his alertness and coordination. An operator on prescription or over-the-counter drugs needs medical approval to safely operate these machines.

KNOW THE RULES

Most employers have rules governing proper operation and maintenance of equipment. Before you start work at a new location, check with your supervisor or the safety coordinator. Ask about rules you may be expected to obey.

Make sure you understand the rules covering traffic at your jobsite. Make sure you recognize and understand the meaning of all signs, flags, and markings. Make sure you understand all hand, flag, whistle, siren, or bell signals. Make sure you know when to use lights, turn signals, flashers and horn.

PROTECT YOURSELF

Wear all the protective clothing and personal safety devices issued to you or called for by job conditions.

You may need:

- A hard hat.
- Safety shoes.
- Safety glasses, goggles, or face shield.
- Heavy gloves.
- Hearing protection.
- Reflective clothing.
- Wet weather gear.
- Respirator or filter mask.

MOUNT AND DISMOUNT PROPERLY

Always use "Three Point Contact" when mounting or dismounting the machine. "Three Point Contact" means that three out of four arms and legs are in contact with the machine at all times during mount and dismount.

Clean your shoes and wipe your hands before mounting machine. Always use hand-hold and step when mounting.

Never use control levers as a hand-hold when mounting or dismounting the machine. Never step on foot controls when mounting or dismounting the machine.

Never attempt to mount a moving machine.

GENERAL OPERATING PROCEDURES

STARTING PROCEDURES

Before operating, walk completely around the machine. Make certain no one is under it, on it or close to it. Let all other workers and bystanders know you are preparing to start the machine. **DO NOT** start machine until everyone is clear.

To start engine...

1. Be properly seated.
2. Set park brake.
3. Move shift selector to NEUTRAL position. Place the neutral lock lever to NEUTRAL LOCK position.
4. Apply brakes.
5. Turn ignition switch clockwise, cranking the engine. (Do not crank the engine longer than 20 seconds. Wait 2 minutes to allow starter to cool down before trying again.)
6. Allow engine to warm up.

Note: *The transmission requires 3 seconds immediately after engine start for self-diagnostics. Always wait at least 3 seconds after engine start before engaging transmission.*

7. In cold weather operation, progressively move each function a small distance back and forth until full cycle has been accomplished.

To make sure warm oil reaches the rear carriage tilt cylinders, slowly raise and lower the boom several times. Failure to cycle the rear carriage tilt cylinders during cold machine start-up can damage the cylinders and structure.

8. Level machine, move frame tilt full to the right, then full to the left, then back to level.
9. Raise boom full up and full down. Extend inner boom full out and retract full in.
10. Tilt attachment full down and full back.
11. Move transfer carriage full forward and full back.

Note: *It is your responsibility to evaluate working conditions and adjust your operation of the forklift accordingly.*

SHUTDOWN PROCEDURES

Correct shutdown is important to the safe operation of the machine.

Always follow these steps:

1. Come to a full stop.
2. Set the park brake.
3. Lower boom to the ground. **DO NOT** leave the operator's compartment while the machine is supporting a load.
4. Place transmission shift selector in NEUTRAL position. Place the neutral lock lever to NEUTRAL LOCK position.
5. Idle engine for 1–3 minutes for gradual cooling. This is especially important for turbocharged engines.
6. Shut off engine.
7. After the engine is shut off, move all hydraulic levers. If any machine movement is detected, a problem **MAY** exist and your supervisor should be advised immediately. **DO NOT** put the machine into service until the problem has been fixed.
8. Remove ignition key.
9. Lock anti-vandalism covers and closures.
10. Dismount.
11. Block wheels if on a slope or incline.

TRAVELING



When traveling over rough terrain, soft ground, or wet/ icy surfaces, slow down and shift to a lower gear.

Travel only at speeds that permit stopping in a safe manner.

When traveling, keep forks as low as possible while maintaining safe clearance with the ground.

- Start and stop machine to check brakes.
- Check park brake by holding on hill.
- Check the three steering modes:
 - ♦ Round
 - ♦ Front Wheel
 - ♦ Oblique

GENERAL OPERATING PROCEDURES

FOLLOW SAFE OPERATING PROCEDURES

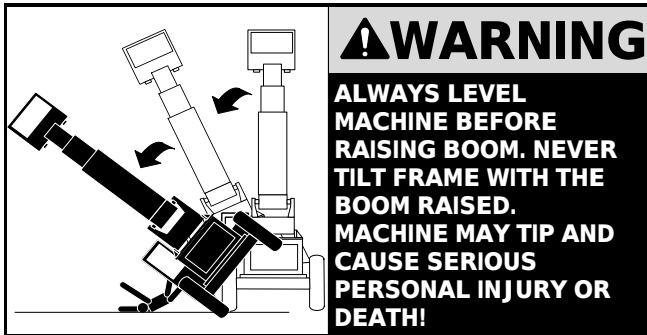

- ALWAYS** check the load chart mounted in the machine before lifting a load. Lift only within the capacity of the machine as shown by the load chart.
- Never tilt the frame when the boom is raised.
- Operate the controls smoothly—don't jerk the hydraulic controls or steering wheel.
- Avoid sudden stops, starts, turns or changes in direction.
- Never “cowboy” or play games with a forklift.
- Operate machine controls only while seated in the operator's compartment.
- Never leave the operator's seat without first lowering the boom to the ground, setting the park brake, and placing transmission in NEUTRAL.



- DO NOT** touch, lean on, or reach through the boom, lift mechanism or transfer carriage areas. **DO NOT** permit others to do so. Never climb on the boom, lift mechanism or transfer carriage.
- STAY ALERT!** Should something break, come loose, or fail to operate on your machine, stop work, shut down the machine and alert your supervisor immediately.

REAR OSCILLATION LOCK SYSTEM

The Rear Oscillation Lock System provides safety and stability by preventing the frame from rotating on the rear axle.

The rear oscillation lock will be operational when any or all of the following conditions apply:

1. When the boom angle exceeds 40°.
2. When the service brakes are applied.
3. If a system component fails.

When the boom angle is above 40°, the following conditions apply:

1. Rear axle cylinder locks, preventing the frame from rotating on the rear axle.
2. Transmission is disengaged.
3. Frame tilt function is disengaged.

Note: When the frame tilt function is disengaged, it **CANNOT** be overridden by the operator unless the boom angle is below 40°.

When the service brakes are depressed, the following conditions apply:

1. Rear axle cylinder locks preventing the frame from rotating on the rear axle.
2. The rear oscillation lock cylinder can be unlocked by the frame tilt function when the boom is below 40°.

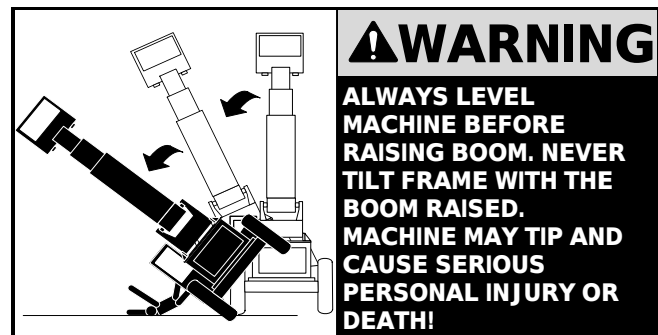

Lower the boom or release the service brake to deactivate the rear oscillation lock system. If the system does not deactivate, a problem exists and must be investigated.

LIFT THE LOAD SAFELY

Important: *ALWAYS* check the load chart mounted in the machine before lifting a load. Lift only within the capacity of the machine as shown by the load chart.

1. If possible, plan to load, unload and turn on flat level ground. If not level, use frame tilt (See "Frame Tilt Control" on page 18) to level machine. Level indicator **MUST** be centered. Be sure there is enough clearance overhead and all around for lifting and traveling. Watch the front and rear clearances when turning.
2. If loads are to be handled several times, place stacking blocks under loads.
3. For sideshift equipped forklifts, center the forks and carriage before lifting.
4. Inspect load to be lifted. Approach the load slowly and squarely with fork tips straight and level. Adjust pallet forks as necessary.
5. Engage the load by moving the transfer carriage slowly forward until the load touches the fork carriage backrest.
6. Tilt the forks back to position the load for travel, then lift the load only enough to clear obstacles.
7. Fully retract the transfer carriage.

TRANSPORT THE LOAD SAFELY

When transporting the load...

- Keep the forks tilted back with boom retracted and the load close to the ground.
- Keep the load as low as possible. Never carry the load above eye level.
- Where the load will obstruct the operator's vision, it is recommended that the forklift be operated in **REVERSE**, looking backwards in the direction of travel. Travel at a slower speed and get someone to direct you.
- Avoid excessively steep slopes or unstable surfaces.** If you must drive on a slope, level the machine, keep the load low and proceed with extreme caution. **DO NOT**, under any circumstances, drive across excessively steep slopes.
- The machine can be levelled side -to-side a total of 12.5° in each direction (22% grade). Any slope or grade that exceeds this is considered excessively steep.
- If a slope is too steep to allow the frame to be leveled, do not raise the boom. The frame must always be level before raising the boom.

WARNING

When traveling over inclines, slopes or ramps...

- ♦ Tilt the attachment back and raised only enough to clear the ground.
- ♦ Avoid turning. If it cannot be avoided, turn slowly and with extreme caution.
- ♦ Travel straight up and down the grades.
- ♦ When loaded and traveling up or down grades, travel with the load uphill.
- ♦ When unloaded, travel only with the forks or attachment downhill.
- ♦ Proceed slowly and with extreme caution.
- ♦ Do not travel across excessively steep slopes or unstable surfaces.

Failure to follow these instructions may result in serious personal injury or death.

- Reduce speed and sound horn at blind intersections, exits and when approaching pedestrians.
- Slow down for turns, ramps, dips, uneven or slippery surfaces and in congested areas.
- Avoid driving over loose objects and holes in roadway surfaces to prevent losing the load or tipping the machine.

GENERAL OPERATING PROCEDURES

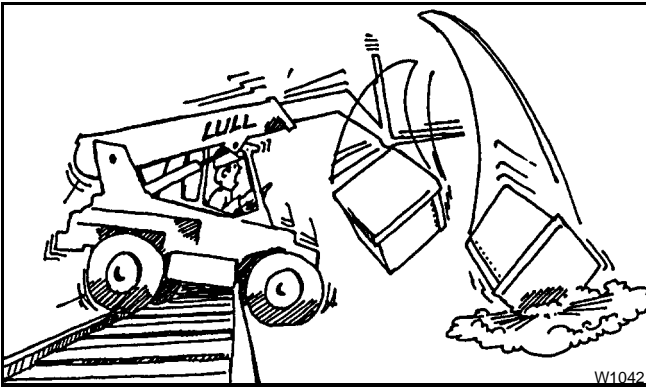

- Avoid crossing ditches, curbs or exposed railroad tracks. If crossing cannot be avoided, keep the load as low as possible, travel very slowly, and proceed with caution.
- Avoid panic braking. Apply brakes smoothly for a controlled stop to prevent toppling the load.

SAFELY PLACING THE LOAD

Elevated or Overhead Placement

Important: *When stacking or placing a load to a high landing use extreme caution! There may be other workers in the immediate area you cannot see. Make sure that all bystanders are away from the area where the load could tip or fall.*

1. Be sure the landing point can safely support the weight of the load. The chosen landing location should be level, both front-to-back and side-to-side.

You should know or be able to estimate the weight and load center of the load that you will be lifting. If you are unsure of the weight and load center of the load, check with your supervisor or with the supplier of the material. **ALWAYS** check the load chart mounted in the machine before lifting a load. Lift only within the capacity of the machine as shown by the load chart.

2. Drive as close as possible to the landing location. Approach very slowly with the load as low as possible.
3. Tilt carriage rearward to cradle the load.

4. Level the machine using frame tilt **BEFORE** the load is raised. (See "Frame Tilt Control" on page 18) **DO NOT** raise the load for placement if the forks are tilted to one side. If the forklift cannot be positioned so the load is level before lifting, reposition the forklift. The likelihood for forklift tipover is greatly increased if the load is not level before lifting.

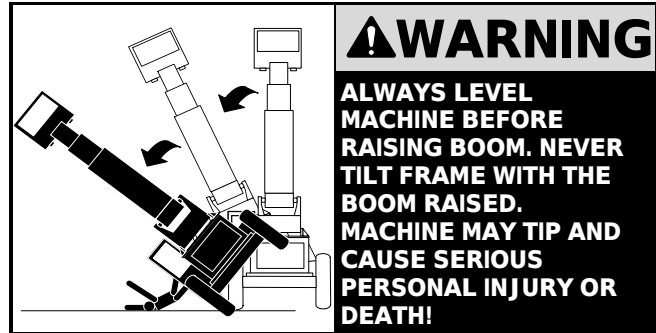

5. Slowly and carefully raise the load. If there is any indication of instability during the lift (i.e. movement, leaning, swaying), stop immediately, lower the load, move the forklift to a more stable, level position. As lift height increases, your depth perception decreases. Placing the load safely at a high elevation may require a signalman to guide you.
6. When the load is slightly higher than the landing point, **SLOWLY** stop the lift.

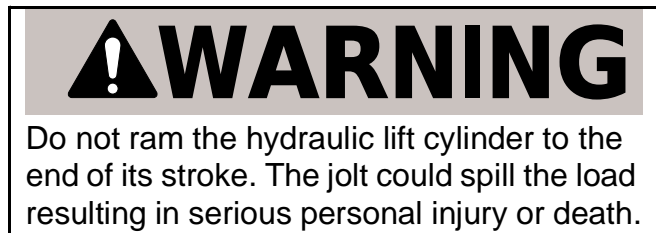

GENERAL OPERATING PROCEDURES

7. Use the transfer carriage to place the load directly over the landing point. The transfer carriage allows safe and easy placement of the load without moving the machine. (Consult load charts for transfer capacity.) Forks should be level and parallel to the landing surface so that they may be easily retracted from under the load. Before retracting the forks, check landing point for any excessive bowing, cracking noises or other indications of overloading.

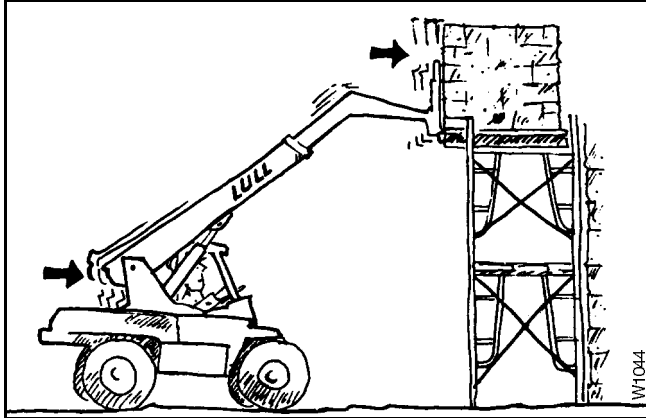

If there is any indication that the landing surface cannot handle the weight of the load, place the load at a different location that you know can handle the weight. If the landing surface cannot handle the weight of the load, pick the load back up, lower it to the ground and lift a lighter load.

8. Lower the load slowly to place it and relieve the weight from the forks. Retract the transfer carriage until the forks are clear of the load. Lower and retract the boom **BEFORE** moving the machine.
9. The forklift can now be moved from the landing location to continue work.

LIFTING PERSONNEL

LULL® strongly recommends that you **DO NOT** use the rough terrain forklift as a personnel lift. It is designed for material handling **ONLY**. If personnel **MUST** be lifted, lift only in accordance with ASME/ANSI B56.6 1992, Para. 5.15 and with a properly designed work platform.

FLUID & LUBRICANT SPECIFICATIONS

GENERAL FLUID AND LUBRICANT SPECIFICATIONS

General Fluid & Lubricant Specifications

System or Component	Fluid or Lubricant	Specification
Fuel System ¹	See "Fuel Requirements"	
Hydraulic System	Heavy Duty Hydraulic Fluid	Amoco Rykon MV or equiv.
Engine Cooling System ¹	Ethylene Glycol/Pure Water Mix with additives.	Low silicate Ethylene Glycol ASTM D5345 ASTM D4985
Engine Oil ¹	See "Engine Oil Specifications"	
Transmission	See "Transmission Oil Specifications"	
Differential (Front & Rear)	Gear Lubricant	SAE 90 API GL-5
Planetary Hub	Use 58 oz. SAE 90 API GL-5 and 4 oz. Friction Modifier, LULL® P26720	
Grease Points	Grease	Lithium-based

1. Consult engine manufacturer's Operator's Manual for additional information.

ENGINE OIL SPECIFICATIONS

John Deere Engines

Use the table below to select the oil viscosity based on expected air temperature range during the period between oil changes. Consult the John Deere Operator's Manual for additional information.

Note: New John Deere engines use special break-in oil for the initial period of operation. Consult engine Operator's Manual for additional information.

Engine Oil Selection Chart, John Deere

Engine Oil, John Deere		
Oil Grade	Temperature Range °F	Temperature Range °C
SAE 5W-30	-22 to +86 °F	-30 to +30 °C
SAE 10W-30	-4 to +86 °F	-20 to +30 °C
SAE 15W-40	+5 to 122 °F	-15 to 50 °C
SAE 30W	+32 to +86 °F	0 to +30 °C
SAE 40W	+50 to +104 °F	+10 to +40 °C
Arctic Oil (e.g. MIL-L-46167B)	Below -22 °F	Below -30 °C
Approved Engine Oil Specifications		
API CD/ CE CCMC Specification D4, D5 SAE 5W-30 SAE 10W-30 SAE 15W-40 SAE 30W SAE 40W MIL-L-46167B		

FLUID & LUBRICANT SPECIFICATIONS

TRANSMISSION OIL SPECIFICATIONS

The following table shows approved lubricants and associated temperature ranges for use with ZF 3WG and 4WG series transmissions.

Transmission Oil Selection Chart

ZF 3WG-100 & 4WG-100 Transmissions		
Oil Grade	Min. Oil Temperature for Starting Engine	Min. Oil Temperature for Engaging Transmission
Engine Oils		
SAE 20W-20	+14 °F (-10 °C)	+41 °F (+5 °C)
SAE 15W-40	+5 °F (-15 °C)	+32 °F (0 °C)
SAE 10W, 10W-30, 10W-40	-4 °F (-20 °C)	+23 °F (-5 °C)
Automatic Transmission Fluid (ATF)		
ATF	-22 °F (-30 °C)	+14 °F (-10 °C)
Approved Lubricants (Engine Oils)		
API CD/ CE/ CF/ SF/ SG MIL-L-2104 C/ D/ E MIL-L-46152 C/ D/ E SAE 10W SAE 10W-30 SAE 10W-40 SAE 15W-40 SAE 20W-20		
Automatic Transmission Fluid (ATF) may only be used at ambient temperatures below +14 °F (-10 °C)		

FUEL REQUIREMENTS

General

Diesel fuels are blended to meet the local temperature requirements. The standard grades are:

- 1D for temperatures -22 to +86 °F (-30 to +30 °C).
- 2D for temperatures +14 to +122 °F (-10 to +50 °C)

There are two main classifications of diesel fuel in general use:

1. Low-sulphur, "on-highway" diesel fuel.
2. Medium-sulfur, "off-highway" diesel fuel. This fuel contains blue dye.

The engine manufacturer specifies the diesel fuel requirements. Additional information can be found below and in the engine manufacturer's Operator's Manual.

Consult your local fuel distributor for the properties of the diesel fuels available in your area.

John Deere Engines

Use of regular-sulfur "off-highway" diesel fuel is recommended.

If low-sulfur "on-highway" diesel fuel is used, John Deere Diesel Fuel Conditioner (TY22030) must be added.

Use of low-sulfur fuel without the specified conditioner may cause premature failure of the engine's fuel system components and void the warranty.

SERVICE/LUBRICATION SCHEDULE MODEL 644B-37

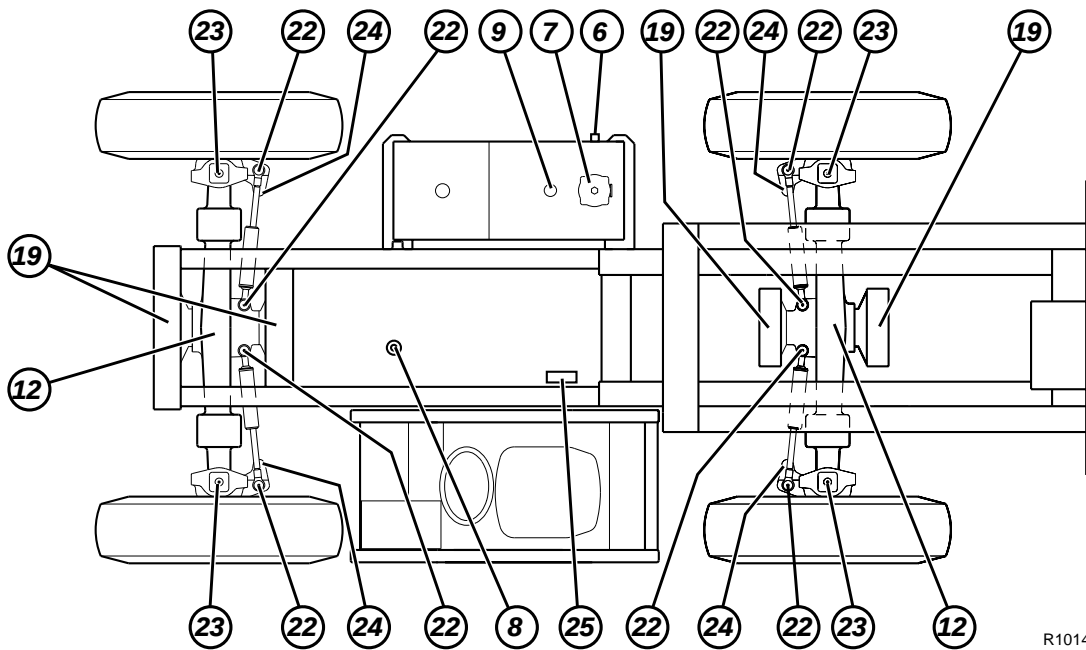

R1014

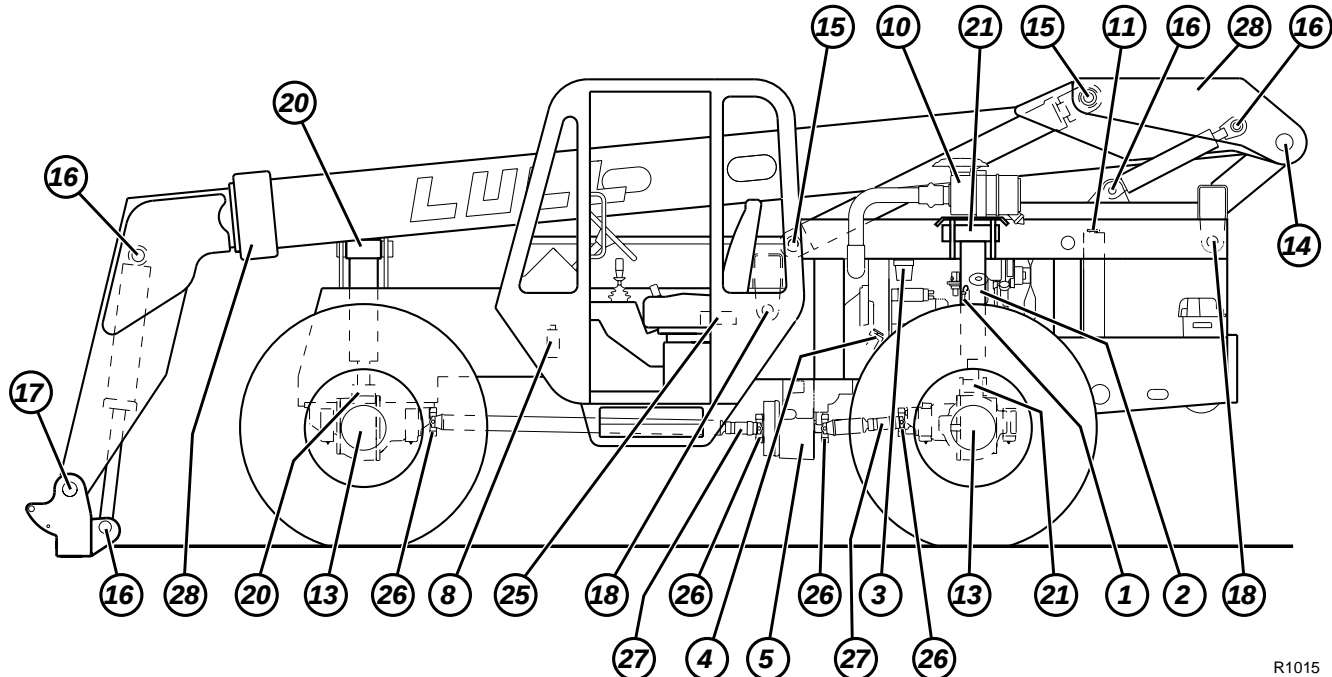

R1015

SERVICE/LUBRICATION SCHEDULE MODEL 644B-37

SYSTEM CAPACITIES AND PRESSURES

HYDRAULIC SYSTEM & RESERVOIR	65 GALS	PLANETARY HUB (EACH)	62 OZ (SEE NOTE 1)
FUEL TANK	40 GALS	ACCUMULATOR (NITROGEN PRECHARGE)	400-425 PSI
COOLING SYSTEM	18 QTS	TIRES — 13.00 X 24	PER TIRE
ENGINE CRANKCASE — JOHN DEERE	14 QTS	PRESSURE	55 PSI
TRANSMISSION — DRAIN/REFILL (APPROX.)	11 QTS	SODIUM CHLORIDE	115 LBS
DIFFERENTIAL	13 QTS	WATER	33 GALS

HOURS OF OPERATION

#	DESCRIPTION	DAILY	WEEKLY	HOURS OF OPERATION							REMARKS
				20	50	100	200	500	1000	2000	
1	ENGINE OIL	C			*CF	CF					SEE ENGINE MANUAL
2	ENGINE OIL FILTER				*R	R					SEE PARTS BOOK
3	FUEL FILTER/WATER SEP.	C						R			SEE PARTS BOOK
4	TRANSMISSION FLUID	C			*CF				CF		SEE OTHER SIDE OF CARD
5	TRANSMISSION FILTER				*R				R		SEE PARTS BOOK
6	HYD. RESERVOIR FLUID	C							CF		SEE OTHER SIDE OF CARD
7	HYD. RETURN FILTER	C			*R				R		SEE PARTS BOOK
8	HYD. PRESSURE FILTER	C			*R				R		SEE PARTS BOOK
9	HYD. TANK BREATHER						CLN		R		SEE PARTS BOOK
10	AIR CLEANER	C					CLN			R	SEE PARTS BOOK
11	ENGINE COOLANT	C								CF	SEE OTHER SIDE OF CARD
12	AXLE DIFFERENTIAL				*CF		C		CF		SAE 90 API-GL-5 LUBE
13	PLANETARY HUBS				*CF		C	CF			SEE NOTE 1
14	BOOM PIVOT	LUBE									<p>* FIRST HOURS OF OPERATION C= CHECK, SERVICE AS NECESSARY CF= CHANGE FLUID R= REPLACE CLN= CLEAN CAREFULLY</p> <hr/> <p>SHORTEN SERVICE INTERVALS ACCORDINGLY WHEN OPERATING UNDER DUSTY OR SEVERE CONDITIONS.</p> <hr/> <p>INSPECT ALL FLUID SYSTEMS AND CHANGE FLUID WHEN FLUID SHOWS TRACES OF CONTAMINATION OR HIGH TEMPERATURES, EVIDENCED BY STRONG ODOR, DISCOLORATION, OR SEPARATION.</p>
15	HOIST PIVOTS	LUBE									
16	TILT CYLINDER PIVOTS	LUBE									
17	QUICK ATTACH PIVOT	LUBE									
18	TRANSFER ROLLERS	LUBE									
19	OSCILLATION PIVOTS	LUBE									
20	FRAME TILT CYLINDER	LUBE									
21	REAR AXLE LOCK CYLINDER		LUBE								
22	STEER CYLINDERS		LUBE								
23	STEER SPINDLES		LUBE								
24	TIE ROD ENDS		LUBE								
25	PARK BRAKE BELLCRANK		LUBE								
26	DRIVE SHAFT U-JOINTS		LUBE								
27	DRIVE SHAFT SLIP YOKES		LUBE								
28	BOOM PADS		LUBE								

NOTES:

1) USE 58 OZ. SAE 90 API GL-5 & 4 OZ. FRICTION MODIFIER, LULL® P26720.

R1013

SERVICE/LUBRICATION SCHEDULE MODEL 644B-42

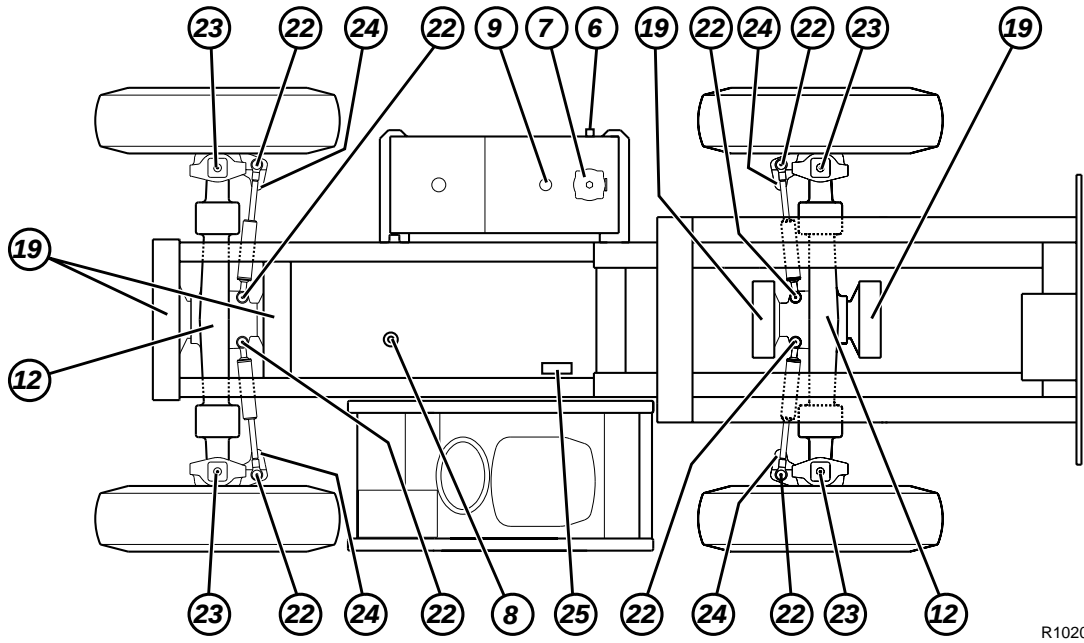

R1020

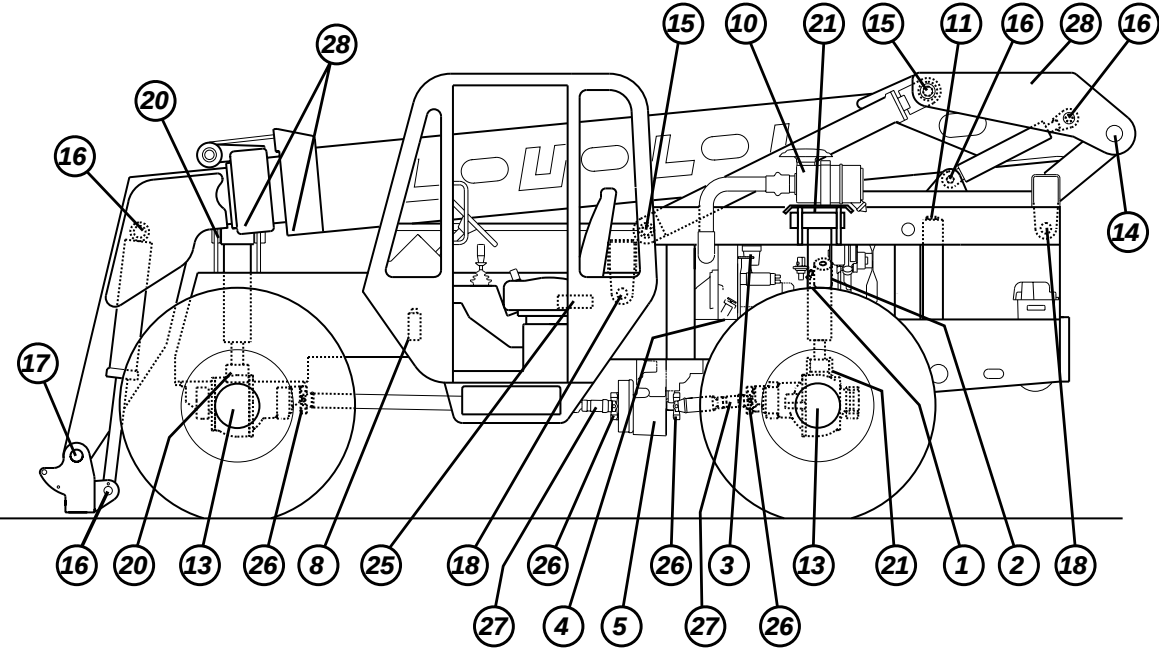

R1021

SERVICE/LUBRICATION SCHEDULE MODEL 644B-42

SYSTEM CAPACITIES AND PRESSURES

HYDRAULIC SYSTEM & RESERVOIR	65 GALS	PLANETARY HUB (EACH)	62 OZ (SEE NOTE 1)
FUEL TANK	40 GALS	ACCUMULATOR (NITROGEN PRECHARGE)	400-425 PSI
COOLING SYSTEM	18 QTS	<u>TIRES — 13.00 X 24</u>	<u>PER TIRE</u>
ENGINE CRANKCASE — JOHN DEERE	14 QTS	PRESSURE	55 PSI
TRANSMISSION — DRAIN/REFILL (APPROX.)	11 QTS	SODIUM CHLORIDE	115 LBS
DIFFERENTIAL	13 QTS	WATER	33 GALS

HOURS OF OPERATION

#	DESCRIPTION	DAILY	WEEKLY	HOURS OF OPERATION							REMARKS
				20	50	100	200	500	1000	2000	
1	ENGINE OIL	C			*CF	CF					SEE ENGINE MANUAL
2	ENGINE OIL FILTER				*R	R					SEE PARTS BOOK
3	FUEL FILTER/WATER SEP.	C						R			SEE PARTS BOOK
4	TRANSMISSION FLUID	C			*CF				CF		SEE OTHER SIDE OF CARD
5	TRANSMISSION FILTER				*R				R		SEE PARTS BOOK
6	HYD. RESERVOIR FLUID	C							CF		SEE OTHER SIDE OF CARD
7	HYD. RETURN FILTER	C			*R				R		SEE PARTS BOOK
8	HYD. PRESSURE FILTER	C			*R				R		SEE PARTS BOOK
9	HYD. TANK BREATHER						CLN		R		SEE PARTS BOOK
10	AIR CLEANER	C					CLN			R	SEE PARTS BOOK
11	ENGINE COOLANT	C							CF		SEE OTHER SIDE OF CARD
12	AXLE DIFFERENTIAL				*CF		C		CF		SAE 90 API-GL-5 LUBE
13	PLANETARY HUBS				*CF		C	CF			SEE NOTE 1
14	BOOM PIVOT	LUBE			2 GREASE FITTINGS		<p>* FIRST HOURS OF OPERATION C= CHECK, SERVICE AS NECESSARY CF= CHANGE FLUID R= REPLACE CLN= CLEAN CAREFULLY</p> <hr/> <p>SHORTEN SERVICE INTERVALS ACCORDINGLY WHEN OPERATING UNDER DUSTY OR SEVERE CONDITIONS.</p> <hr/> <p>INSPECT ALL FLUID SYSTEMS AND CHANGE FLUID WHEN FLUID SHOWS TRACES OF CONTAMINATION OR HIGH TEMPERATURES, EVIDENCED BY STRONG ODOR, DISCOLORATION, OR SEPARATION.</p>				
15	HOIST PIVOTS	LUBE			4 GREASE FITTINGS						
16	TILT CYLINDER PIVOTS	LUBE			6 GREASE FITTINGS						
17	QUICK ATTACH PIVOT	LUBE			1 GREASE FITTINGS						
18	TRANSFER ROLLERS	LUBE			4 GREASE FITTINGS						
19	OSCILLATION PIVOTS	LUBE			4 GREASE FITTINGS						
20	FRAME TILT CYLINDER	LUBE			2 GREASE FITTINGS						
21	REAR AXLE LOCK CYLINDER		LUBE		2 GREASE FITTINGS						
22	STEER CYLINDERS		LUBE		8 GREASE FITTINGS						
23	STEER SPINDLES		LUBE		8 GREASE FITTINGS						
24	TIE ROD ENDS		LUBE		4 GREASE FITTINGS						
25	PARK BRAKE BELLCRANK		LUBE		1 GREASE FITTINGS						
26	DRIVE SHAFT U-JOINTS		LUBE		4 GREASE FITTINGS						
27	DRIVE SHAFT SLIP YOKES		LUBE		2 GREASE FITTINGS						
28	BOOM PADS		LUBE		4 FITTINGS + SLIDES						

NOTES:

1) USE 58 OZ. SAE 90 API GL-5 & 4 OZ. FRICTION MODIFIER, LULL® P26720.

R1019

SAMPLE LOAD CHART

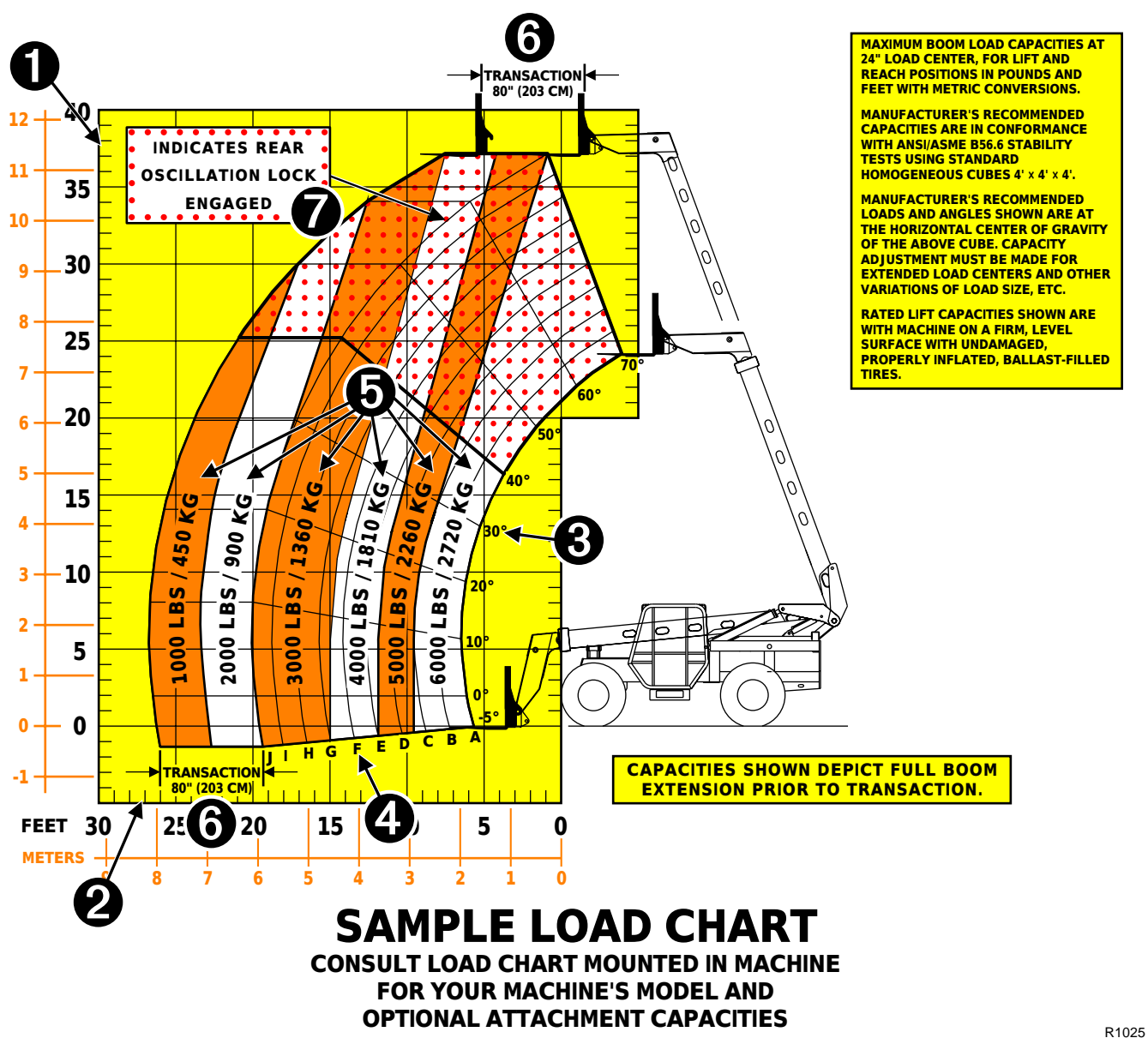

R1025

- ❶ VERTICAL SCALE SHOWS DISTANCE ABOVE AND BELOW GROUND LEVEL.
- ❷ HORIZONTAL SCALE SHOWS DISTANCE FROM FRONT WHEELS.
- ❸ BOOM ANGLE SCALE REPRESENTS THE BOOM ANGLE RELATIVE TO LEVEL GROUND.
- ❹ LETTERED ARCS SHOW THE AMOUNT OF BOOM EXTENSION AND THE ROTATION OF THE BOOM AT THESE EXTENSIONS.
- ❺ LOAD AREAS SHOW MAXIMUM RATED LOAD CAPACITIES. EACH AREA DEFINES THE CAPACITY THAT MAY BE LIFTED AND PLACED. FOR EASE OF READING, HEAVY LINES AND DIFFERENT COLORS SEPARATE THESE AREAS.
- ❻ TRANSACTION AREA SHOWS THE ADDITIONAL 80 INCH AREA THAT MAY BE REACHED BY MOVING THE TRANSFER CARRIAGE WITH A FULLY EXTENDED BOOM. (Models 644B, 844C, and 1044C only.)
- ❼ THE AREA FILLED WITH RED DOTS SHOWS WHERE THE REAR AXLE IS LOCKED AND FRAME TILT AND DRIVE ARE DISABLED. See "Rear Oscillation Lock System" on page 22.

DRIVE LOCKOUT OVERRIDE

Important: Read and understand the following instructions **BEFORE** using the optional Drive Lockout Override System!

Theory of Normal Operation

This machine is equipped with a stabilization system that does several things to increase lateral (side-to-side) stability.

When the boom is raised above 20° elevation:

- The transmission is limited to first and second gears.
- The rear oscillation lock cylinder is limited to slow (orificed) movement.
- The speed of the frame tilt function is limited.

When the boom is raised above 40° elevation:

- The rear axle stabilization cylinder is locked, preventing the frame from rotating on the rear axle.
- The transmission is disengaged, stopping drive capabilities.

These functions help prevent tipover accidents which can cause serious injuries and death. The owner/operator manual describes the normal use and operation of a telescopic handler and tells the operator to carry the load and forks as low as possible, but not above eye level.

The Rear Oscillation Lock System stops the machine from driving when the boom angle is above 40°. Driving with the boom elevated (loaded or empty) can be very dangerous, especially on uneven terrain. The machine's center of gravity is highest when the boom is elevated, which makes it less stable laterally as the boom is raised higher. Improperly driving the machine introduces dynamics that can add to instability and lead to a tipover.

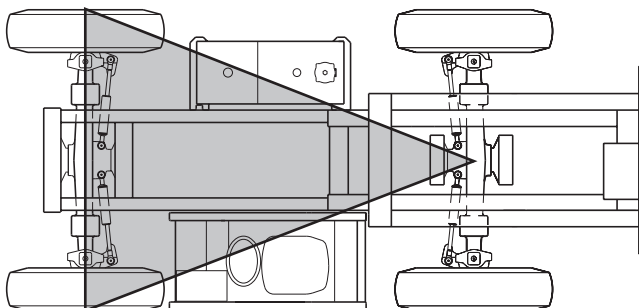

Diagram 1: Stability Triangle (Front axle locked and frame free to rotate on rear axle)

Diagram 2: Stability Rectangle (Front and rear axles locked, preventing frame from rotating)

When the boom angle is below 20° the machine operates with a freely oscillating rear axle to negotiate rough terrain. (See Diagram 1)

When the boom angle is above 20°, the rear axle cylinder is orificed, slowing movement of the frame on the rear axle. This increases the lateral (side-to-side) stability.

When the boom angle is above 40°, the rear axle cylinder locks, preventing the frame rotating on the rear axle. This changes the stability diagram from a triangle to a rectangle (when viewed from above) and substantially increases the machine's lateral stability. (See Diagram 2)

General Description, Drive Lockout Override System

In some special applications, it is not possible to carry or place the required load unless the machine is driven with an elevated boom. The Drive Lockout Override System is designed to allow this and **MUST BE USED WITH EXTREME CARE!**

The Drive Lockout Override System does two things when engaged with the boom angle above 40°:

- Allows the transmission to be engaged in first gear only.
- Unlocks the rear oscillation lock cylinder and allows very slow (orificed) movement. This increases dynamic lateral stability while the machine is being driven.

GENERAL OPERATING PROCEDURES - SUPPLEMENT

Operation of the Drive Lockout Override System

To operate the Drive Lockout Override System:

WARNING

Failure to follow the instructions in this supplement and the owner/operator manual may result in serious personal injury or death!

Note: These procedures only apply to situations where the boom is above 40° elevation.

1. Plan your route of travel. The surface must be firm and as level as possible. Always avoid rough or steep areas.
2. Level the frame before picking up the load. If load is suspended (slung load), make sure tag lines are secure and manned. Never let a slung load sway, as this may lead to machine tipover or injury to personnel.
3. With the brakes on, move the shift selector to the Forward or Reverse position.
4. Using your left foot, press and hold down the Drive Lockout Override Switch. The drive will engage in first gear only and the machine may be moved.
5. Drive the machine very slowly, while carefully watching the terrain. Make turns smoothly and slowly.
6. Use the service brakes to stop the machine slowly and smoothly. Releasing the Drive Lockout Override Foot Switch will disengage the drive, but this will not activate the brakes.



ALWAYS LEVEL MACHINE BEFORE RAISING BOOM. WHEN DRIVE LOCKOUT OVERRIDE IS USED TO MOVE MACHINE WITH BOOM ELEVATED, FRAME LEVEL CAN CHANGE WITH CHANGING TERRAIN. ADJUST FRAME TILT TO KEEP FRAME AND BOOM AS LEVEL AS POSSIBLE WHILE DRIVING. NEVER EXCEED $\pm 5^\circ$ FROM LEVEL. LEVEL FRAME SLOWLY AND CAREFULLY. FAILURE TO FOLLOW THE INSTRUCTIONS IN THIS SUPPLEMENT AND THE OWNER/OPERATOR MANUAL MAY RESULT IN SERIOUS PERSONAL INJURY OR DEATH!



TRANSFER OF OWNERSHIP

To: JLG, Gradall, Lull and Sky Trak product owner:

If you now own, but ARE NOT the original purchaser of the product covered by this manual, we would like to know who you are. For the purpose of receiving safety-related bulletins, it is very important to keep JLG Industries, Inc. updated with the current ownership of all JLG products. JLG maintains owner information for each JLG product and uses this information in cases where owner notification is necessary.

Please use this form to provide JLG with updated information with regard to the current ownership of JLG Products. Please return completed form to the JLG Product Safety & Reliability Department via facsimile (717) 485-6573 or mail to address as specified on the back of this form.

Thank you,
Product Safety & Reliability Department
JLG Industries, Inc.
1 JLG Drive
McConnellsburg, PA 17233-9533
Telephone: (717) 485-5161
Fax: (717) 485-6573

NOTE: Leased or rented units should not be included on this form.

Mfg. Model: _____

Serial Number: _____

Previous Owner: _____

Address: _____

City: _____ State: _____

Zip: _____ Telephone: (_____) _____

Date Of Transfer: _____

Current Owner: _____

Address: _____

City: _____ State: _____

Zip: _____ Telephone: (_____) _____

Who in your organization should we notify?

Name: _____

Title: _____

Please cut on the dotted line and fax to 717-485-6573





Corporate Office
JLG Industries, Inc.
1 JLG Drive
McConnellsburg PA. 17233-9533
USA
Phone: (717) 485-5161
Fax: (717) 485-6417

JLG Worldwide Locations

JLG Industries (Australia)
P.O. Box 5119
11 Bolwarra Road
Port Macquarie
N.S.W. 2444
Australia
Phone: (61) 2 65 811111
Fax: (61) 2 65 810122

JLG Industries (UK)
Unit 12, Southside
Bredbury Park Industrial Estate
Bredbury
Stockport
SK6 2sP
England
Phone: (44) 870 200 7700
Fax: (44) 870 200 7711

JLG Deutschland GmbH
Max Planck Strasse 21
D-27721 Ritterhude/Ihlpohl
Bei Bremen
Germany
Phone: (49) 421 693 500
Fax: (49) 421 693 5035

JLG Industries (Italia)
Via Po. 22
20010 Pregnana Milanese - MI
Italy
Phone: (39) 02 9359 5210
Fax: (39) 02 9359 5845

JLG Latino Americana Ltda.
Rua Eng. Carlos Stevenson,
80-Suite 71
13092-310 Campinas-SP
Brazil
Phone: (55) 19 3295 0407
Fax: (55) 19 3295 1025

JLG Europe B.V.
Jupiterstraat 234
2132 HJ Foofddorp
The Netherlands
Phone: (31) 23 565 5665
Fax: (31) 23 557 2493

JLG Industries (Norge AS)
Sofeimyrveien 12
N-1412 Sofienyr
Norway
Phone: (47) 6682 2000
Fax: (47) 6682 2001

JLG Polska
Ul. Krolewska
00-060 Warszawa
Poland
Phone: (48) 91 4320 245
Fax: (48) 91 4358 200

JLG Industries (Europe)
Kilmartin Place,
Tannochside Park
Uddingston G71 5PH
Scotland
Phone: (44) 1 698 811005
Fax: (44) 1 698 811055

JLG Industries (Pty) Ltd.
Unit 1, 24 Industrial Complex
Herman Street
Meadowdale
Germiston
South Africa
Phone: (27) 11 453 1334
Fax: (27) 11 453 1342

Plataformas Elevadoras
JLG Iberica, S.L.
Trapadella, 2
P.I. Castellbisbal Sur
08755Castellbisbal
Spain
Phone: (34) 93 77 24700
Fax: (34) 93 77 11762

JLG Industries (Sweden)
Enkopingsvagen 150
Box 704
SE - 175 27 Jarfalla
Sweden
Phone: (46) 8 506 59500
Fax: (46) 8 506 59534
